

\$1.00

CATALOG NO. 103



VANADIUM-EXTRA

**Special Tools for**  
**VOLKSWAGEN**  
**and Other European Machines**

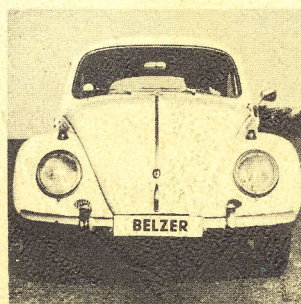

**BELZER TOOLS**

747 SEWARD STREET, LOS ANGELES, CALIFORNIA 90038

TELEPHONE: (213) 463-9377

This catalog celebrates our 11th year of serving the automobile industry.

Our company is grateful for your continued loyalty, and will continue to work for you and with you.

These designs and prices supersede all previous ones; as we continue to upgrade our products, we do reserve the right to modify these prices without formal notice.

All rights reserved. Copying or reproduction of any part, or all, of this catalog is forbidden without the express written consent of the owner, Mr. Richard M. Lucas.

Normal terms are C.O.D., F.O.B., Los Angeles, Calif.

Minimum order \$10.00, shipping by best method.

California residents please include 5% tax.

**COMPLETE VW PULLER SET**

- 2** Rear bearing flange puller
- 3** Brake drum puller
- 4** Crankshaft gear puller
- 9** Transporter king pin puller
- 20** Generator bearing puller
- 201** Oil pump puller
- 203B** Crankshaft pulley puller
- 204B** Crankshaft oil seal installer
- 212A** Piston pin bush puller
- 228A** Starter bushing puller
- L241A** Rear axle bearing puller, new
- 266HS** Sedan tie rod end puller
- 266HT** Transporter tie rod end puller

**1**

**2**

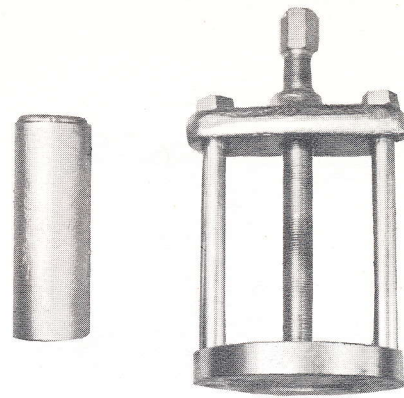

Rear bearing flange puller with spacing bush

**3**

**4**

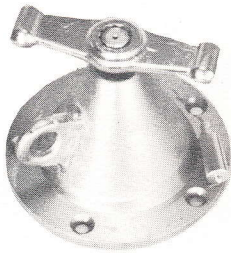

Rear drum puller, old models

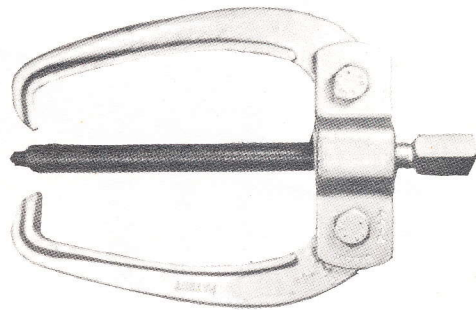

Crankshaft gear puller



**NEU**

**5**

**6**

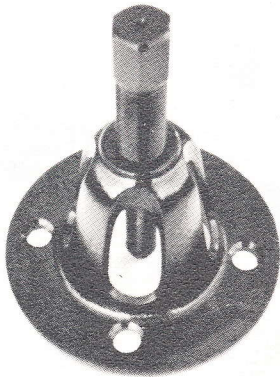

Rear drum puller, 1600

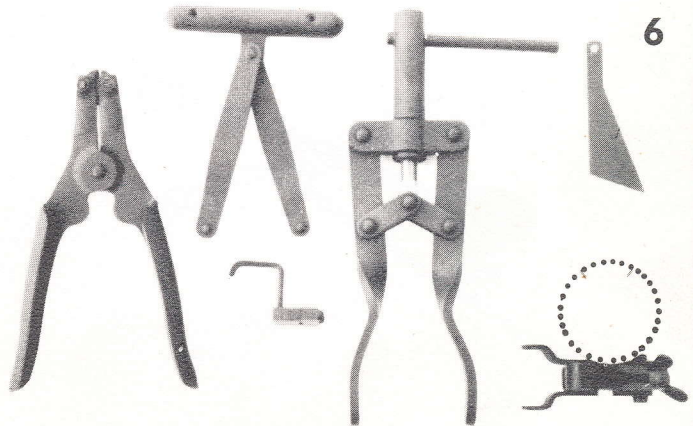

Disc brake tool set

**7**

**8**

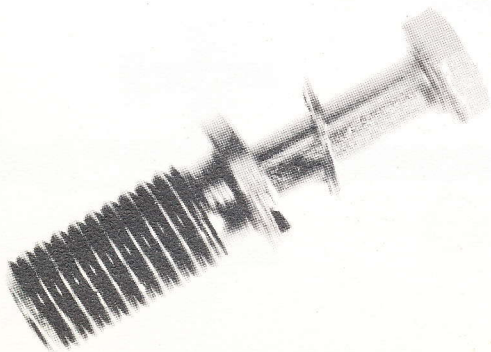

Oversize rocker arm stud for 40hp, short type requiring .004" valve setting

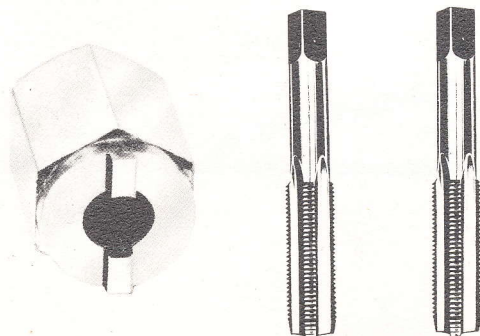

Kit for installing stud #7

9

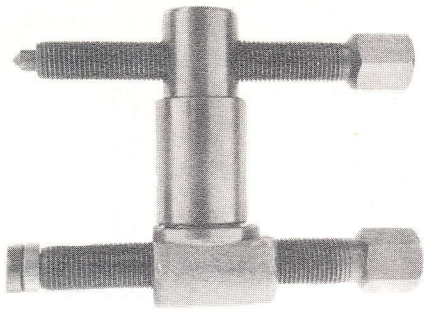

Transporter king pin puller

10

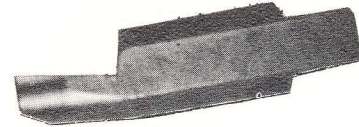

Hub cap clip riveting mandrel

11



Fan pulley nut and generator nut double box wrench, flat, 21 x 36mm

12



Drain plug and fan pulley wrench

13

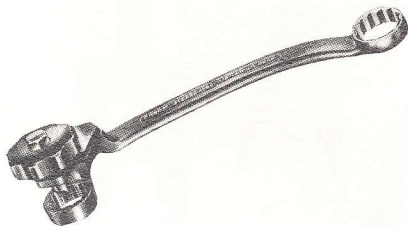

Steering adjusting wrench, 1500 sedan

14



Case modifier for accommodating late 40hp cam followers

15

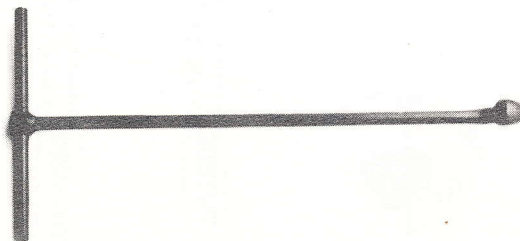

10mm special wrench for fan cowl;  
Late model intake manifold nuts

New

16

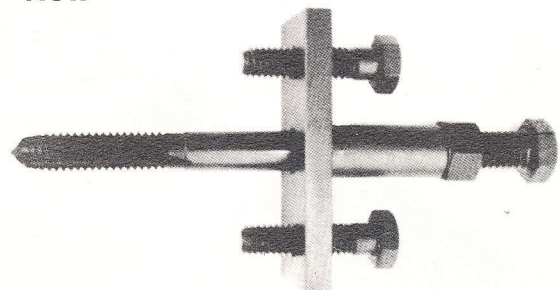

Fuel pump spacer puller

17

New

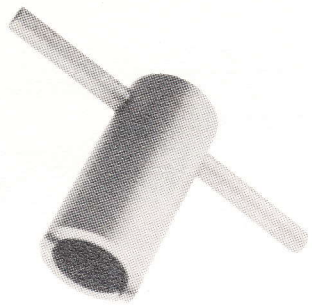

Glove box lock wrench

18

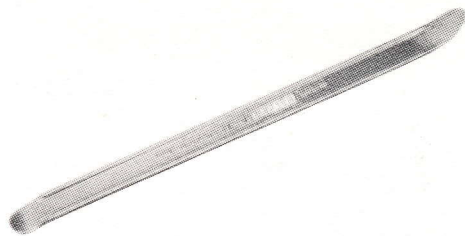

Universal pry bar

19

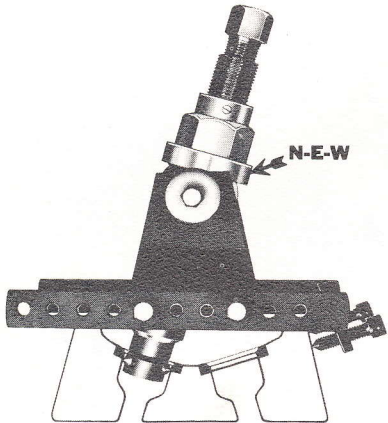

Valve seat puller



20



Generator bearing puller

21

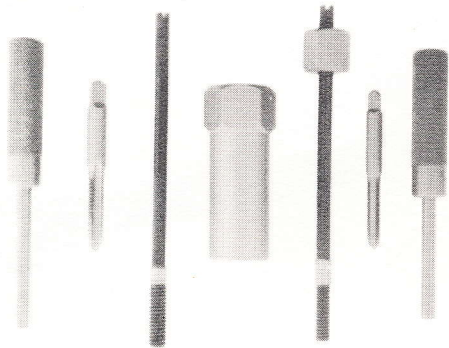

Valve guide removal & installing kit for 7 and 8mm guides

22

New

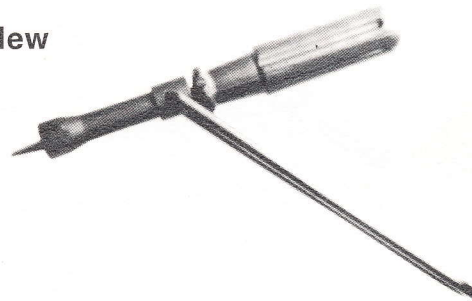

Special valve adjusting wrench, 13mm

23

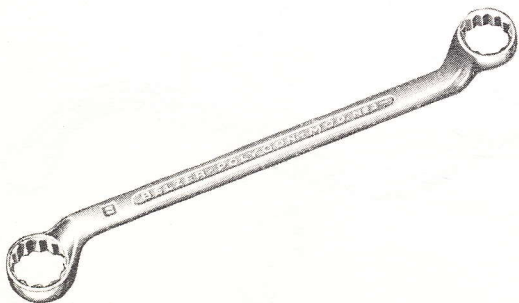

13 x 14mm Valve adjusting wrench  
A. 17 x 19mm General purpose wrench

24

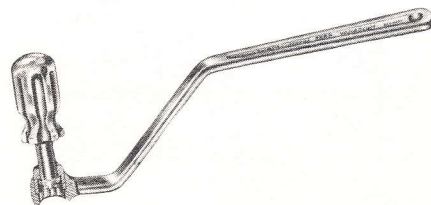

Valve adjusting tool, 1500 sedan

25

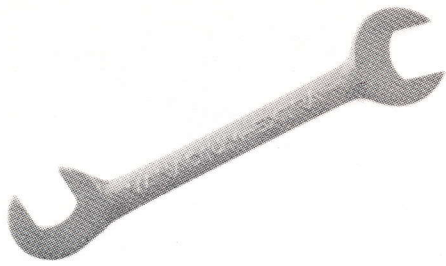

Magneto and carburetor wrench, 82° & 15°: 4-19mm

26

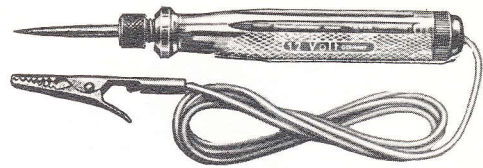

Timing and test light, 2-12v

27

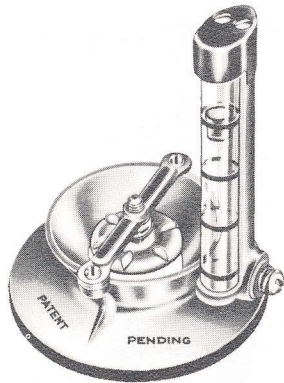

Carburetor synchronizer for 1500S and Porsche (P75)

28

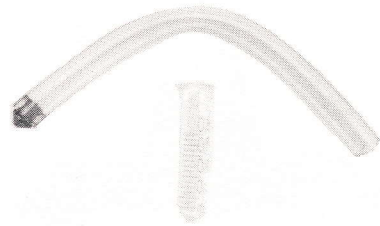

Accelerator pump vial Assy, 1500S-1600

29

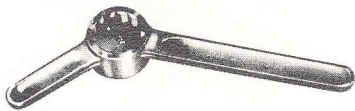

Engine mount bolt wrench, magnetic

30



Double ratcheting box wrench, 17 x 21mm

31

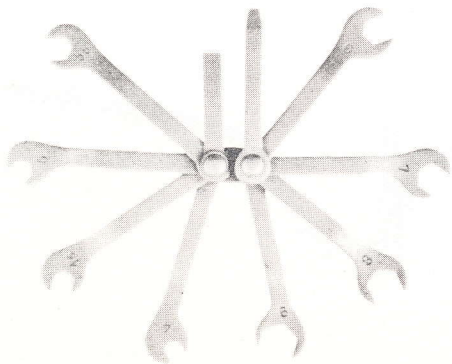

Wrench Set: 4, 4.5, 5, 5.5, 6, 7, 8 & 9mm

32

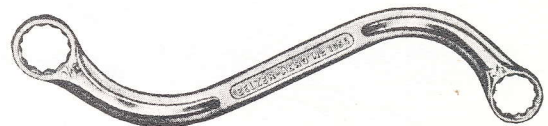

Heater junction box wrench, 13 x 14mm

New

33

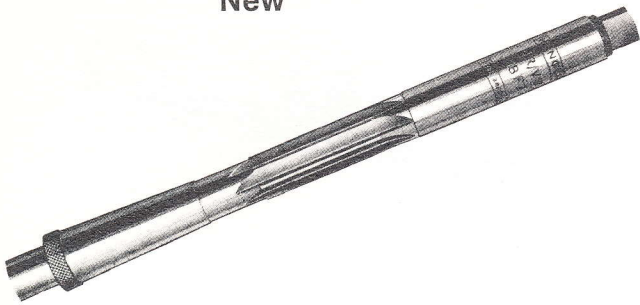

A. Fixed king pin reamer, sedan, 18mm  
B. Fixed king pin reamer, transp., 22mm

34

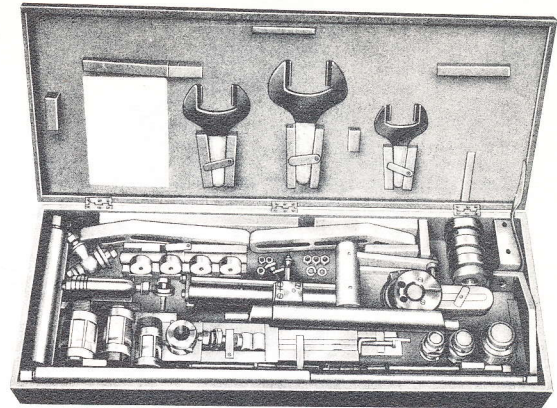

Complete crankcase machining set, with planer and reamers, in box

35

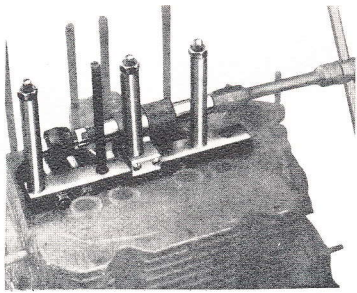

Connecting rod bush reaming set, 1500-1600



36

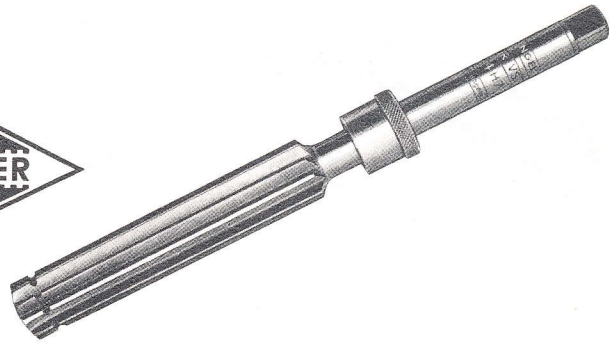

Drop arm bush reamer, hard chrome plated

37

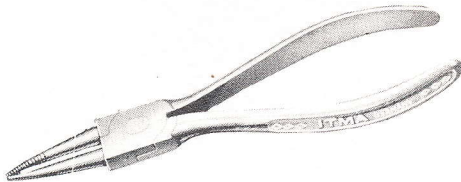

Axle shaft large circlip pliers, late model, 220mm long

38

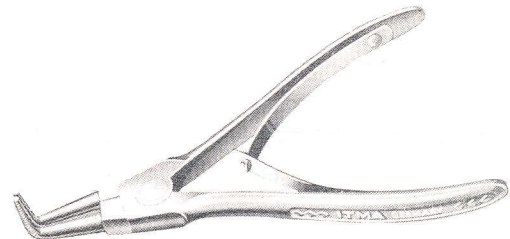

A. 125mm corclip pliers for clutch return spring  
B. 170mm circlip pliers for synchromesh transmission

39

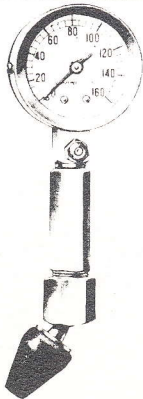

Compression tester for all models including Porsche, 0-300 lbs.

40

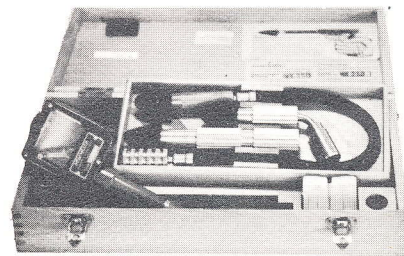

MOTOMETER recording compression tester set, 0-250 lbs. in box. Cards and parts on request

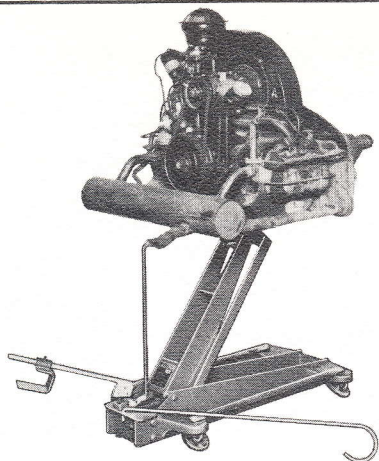

41

Hydraulic jack with engine adaptor

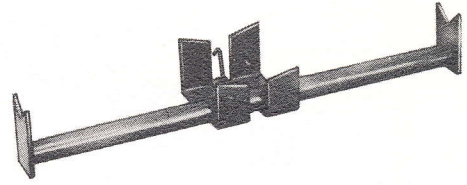

42

Transmission adaptor for #41

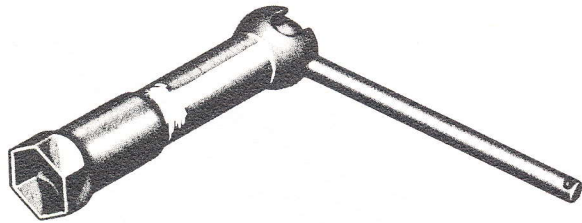

43

Spark plug wrench, 36 and 40hp

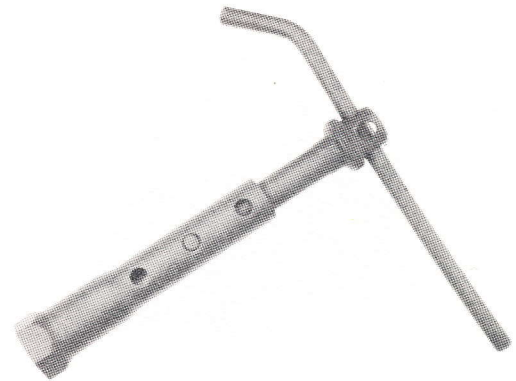

44

Adjustable spark plug wrench, all models

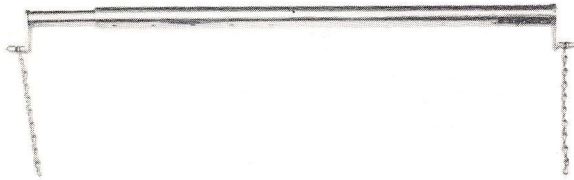

45

Toe-in bar gage

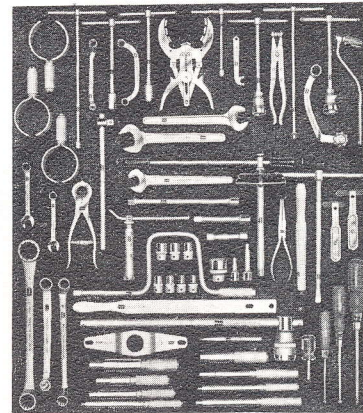

46

Workshop tool set on wall board, 68 most basic special tool

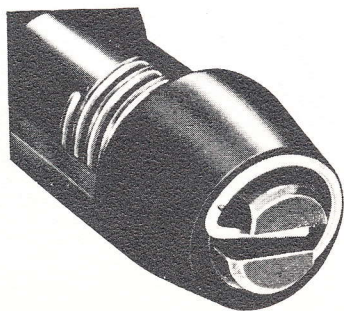

47

Spark plug Heli-Coil set, 14 x 1.25 mm

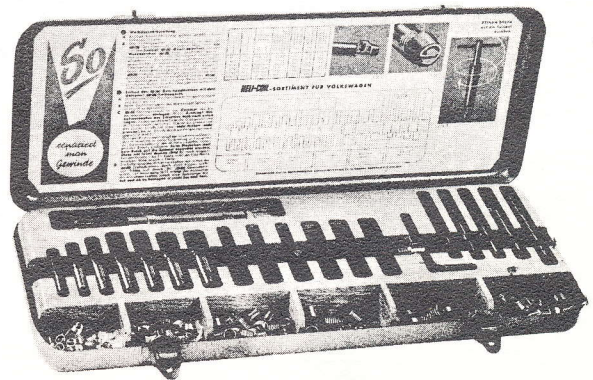

48

Metric Heli-Coil set: 6 x 1, 7 x 1, 8 x 1.25, 10 x 1.5, 12 x 1.5 & 14 x 1.5mm



49

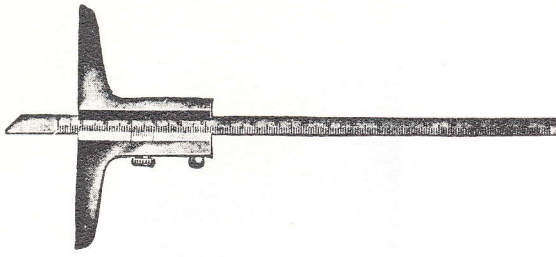

- A. 150mm Depth caliper .1mm
- B. 200mm Depth caliper .1mm
- C. 250mm Depth caliper .1mm

50

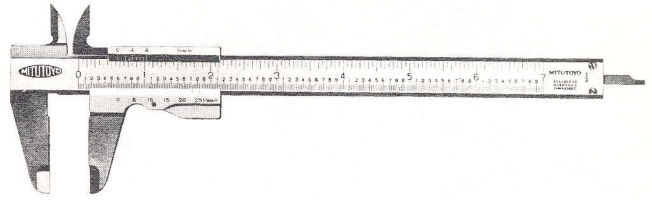

- A. 120mm Vernier caliper .1mm
- B. 150mm Vernier caliper .02mm x .001"
- C. 200mm Vernier caliper .02mm x .001"
- D. 250mm Vernier capiler .02mm x .001"

51

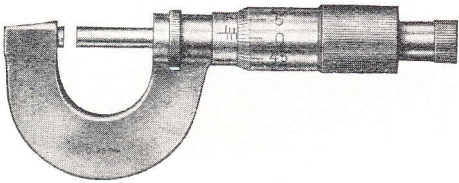

- A. 0-15 Micrometer .01mm
- B. 0-25 Micrometer .001mm carbide tips
- C. 25-50 Micrometer .001mm carbide tips
- D. 50-75 Micrometer .01mm carbide tips
- E. 75-100 Micrometer .01mm carbide tips
- F. 0-100 Micrometer .01mm



52

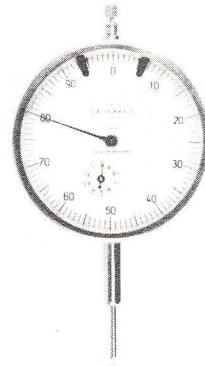

Metric dial gage .01mm x 10mm

53

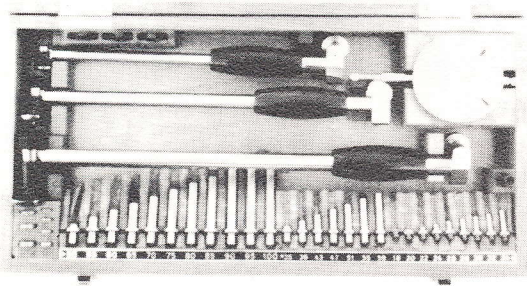

Original SUBITO bore gage, 18-100mm

- A. Cylinder bore gage set, 50-100mm

54

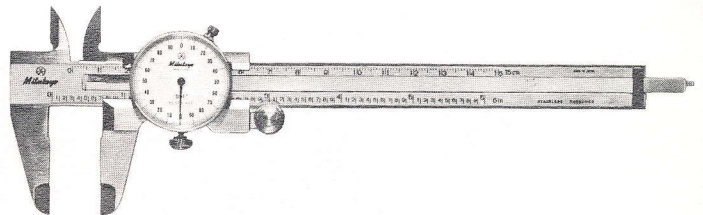

Metric dial caliper, hardened, stainless, 150mm

55

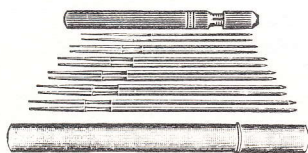

Metric jet reamer set, .6-1.9mm

56

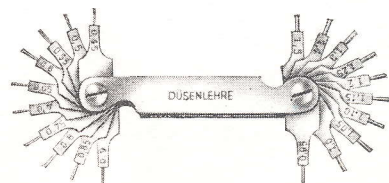

- A. Metric jet gage, .45-1.5mm
- B. Metric jet gage, 1.5-3.0mm

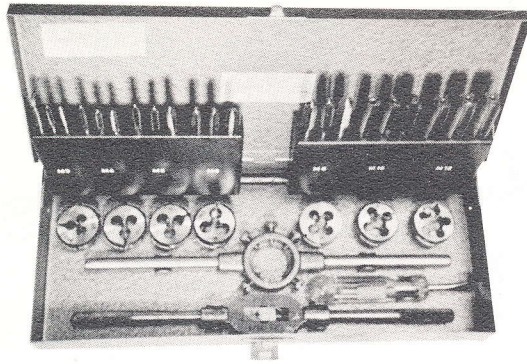

57

**Gewindeschneidzeug, kompl., im Kasten**

Inhalt: M 3, 4, 5, 6, 8, 10, 12 mm WS

Taps and dies, 1-35mm, on request

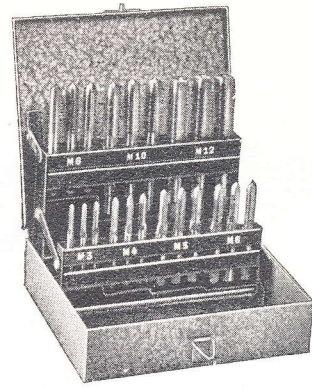

58

**Gewindebohrer, kompl. im Kasten**

Inhalt: M 3, 4, 5, 6, 8, 10, 12 mm

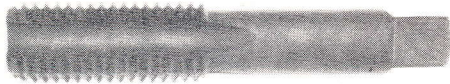

59

- A. 6x1 for Oil strainer cover
- B. 8x1 for Rocker arm adjusting screw
- C. 8x1.25 for Muffler stud
- D. 10x1 for Oil pressure & lite switches
- E. 10x1.5 for Cylinder case stud
- F. 12x1.5 for Oversize case stud & sedan wheel lug
- G. 14x1.25 for Spark plug
- H. 14x1.5 for Transporter wheel lug
- I. 18x1.5 for Oil drain plug & spark plug sleeve
- J. 20x1.5 for Crankshaft, pulley end
- K. 28x1.5 for Crankshaft, flywheel end

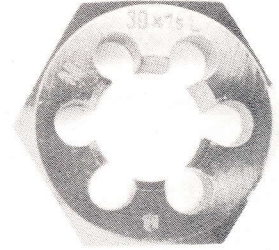

60

- A. 7x1 for Starter armature shaft
- B. 12x1.5 for Generator armature shaft
- C. 16x1.5R for Stub axle, 1500-1600, right
- D. 16x1.5L for Stub axle, 1500-1600, left
- E. 18x1R for Stub axle, 1500 transporter, right
- F. 18x1L for Stub axle, 1500 transporter, left
- G. 22x1.5R for Stub axle, old transporter, right
- H. 22x1.5L for Stub axle, old transporter, left
- I. 24x1.5 for Rear axle, all sedans & old Transporter
- J. 30x1.5 for Rear axle, 1500 transporter

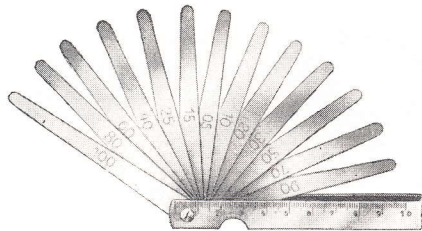

61

Metric feeler gage set



62

Metric feeler gage strips, 300mm long:  
.100, .150, .200, .300mm

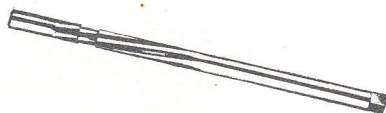

63

Metric valve guide reamers, HSS, 6, 7, 8, 9, 10, 12mm



64

German hammer:  
100, 200, 300, 400, 500, 600, 800, 1,000 g.

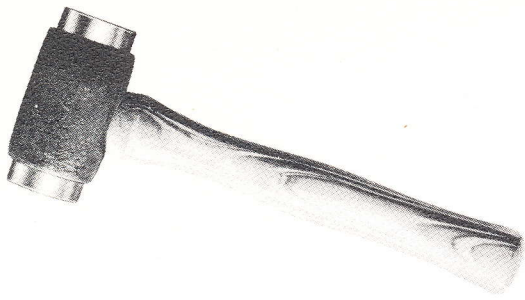

65

Copper hammer for separating cases and for knock-off wheel nuts, 2kg.

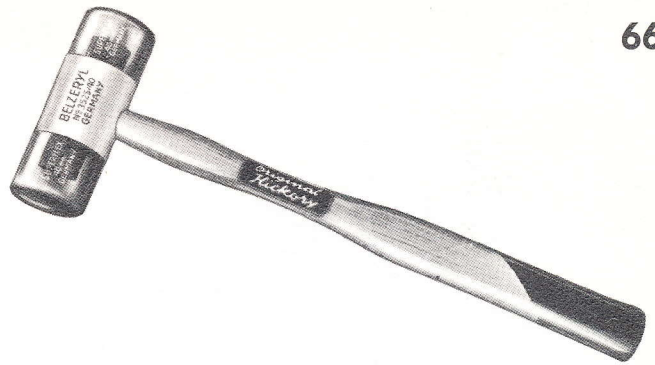

66

Nylon head hammer: 22, 27, 32, 35, 40, 50, 60, 75mm across face

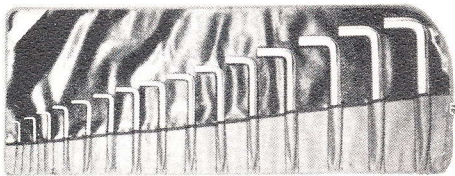

67

- A. Metric allen set in plastic roll:  
3, 4, 5, 6, 8, 10, 12, 14 & 17mm
- B. Set: 2, 3, 4, 5, 6, 7, 8, 9, 10, 11, 12mm



A product of the BELZER-WORKS  
from Chrome-Vanadium Steel  
Best Quality guaranteed.

68

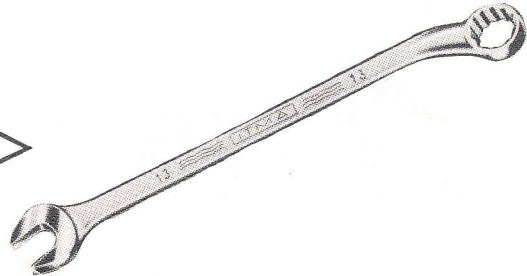

- M. Combination wrench set in roll, 6-22mm inclusive
- A. Same, 1/4" through 3/4" by 1/16" American
- E. Same, BSW 1/8" through 5/8" by 1/16" English

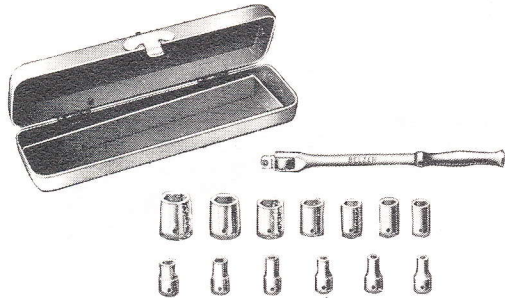

69

Metric 1/4" drive socket set in metal box, 4-14mm with 4.5 and 5.5mm



70

Metric 3/8" drive socket set in metal tray, 9-22mm, 6 or 12-point.

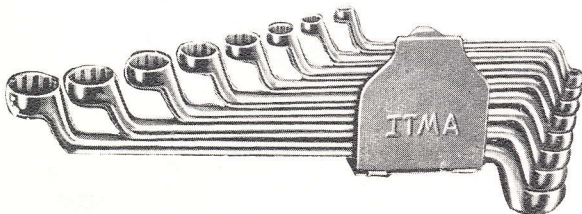

71

EIN PRODUKT DES BELZER-WERKES  
aus CHROM-VANADIUM-Stahl  
in bester Ausführung mit  
Garantie-Erklärung

Metric double box wrench set, 6-22mm



72

Un produit des Usines BELZER en Acier  
au Chrome-Vanadium. Première Qualité.  
Garantie contre tous vices de  
fabrication et de matériaux.

Metric double open wrench set 6-22mm

73



Metric HSS drill set in metal case, 1-13 by 1/2mm.  
Individual drills 1-13 on request

74



Metric thread file

75

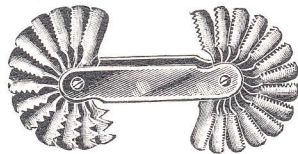

Metric thread gage

76

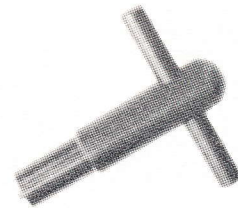

Dashboard switch screwdriver

77

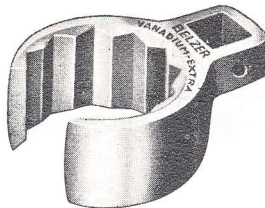

Metric crowfoot wrench: 8, 9, 10, 11, 12, 13, 14, 15,  
17, 18, 19, 20 and 22mm

78

New

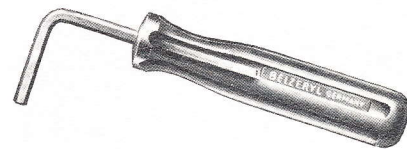

Plastic handled metric allen wrench: 3, 3.5, 4, 5, 6, 8, 10, 12mm

79



Double box wrench, flat pattern: 8 x 9, 9 x 11, 10 x 11,  
12 x 13, 12 x 14, 14 x 15, 17 x 19 & 18 x 19mm

80

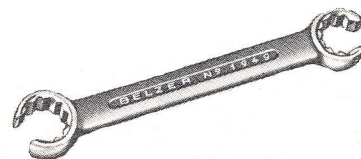

Flare nut wrench: 10 x 11, 10 x 12, 12 x 14 & 17 x 19mm

81

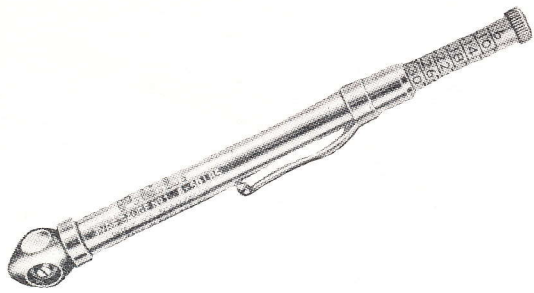

Pocket tire gage, polished chromed, 6-50 lbs. by single pound increments; with valve core remover, pocket clip & protective cap

82

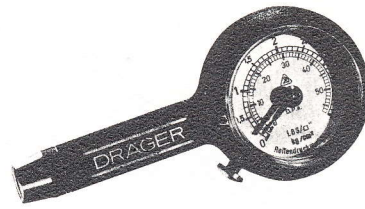

DRAGER tire gage, kg. and lb.

83

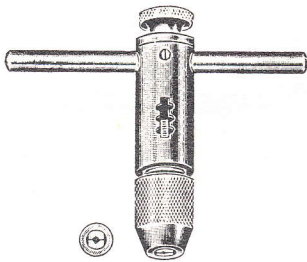

Ratcheting tap wrench, reversing, bright nickel finish



106

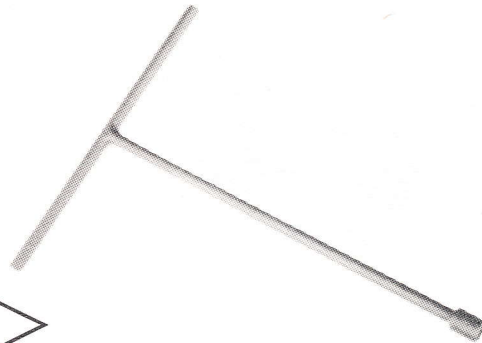

Oil strainer T wrench; also crankcase & fan cowling bolts etc.

109

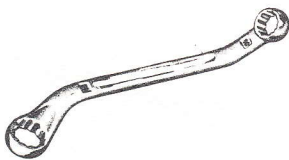

Oil cooler nuts and exhaust manifold nuts box wrench, 10 x 14mm

113



Front wheel bearing wrenches, 27mm  
A. 32mm for transporter  
B. 24mm for 1500 sedan

114

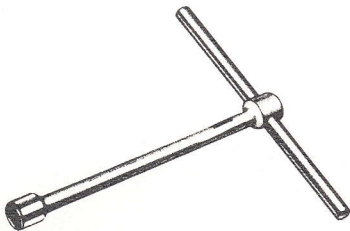

Gearshift rod coupling screw wrench  
A. For 1500 application

121B

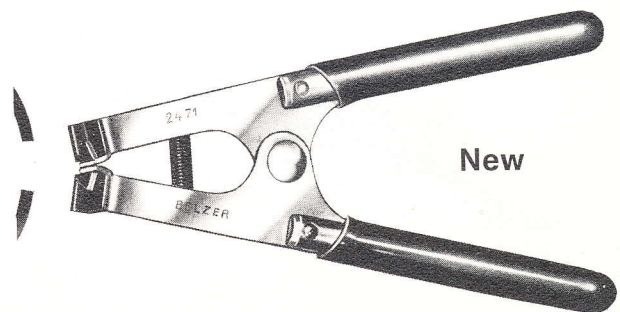

Piston ring remover & installer for all models, including Porsche

122B

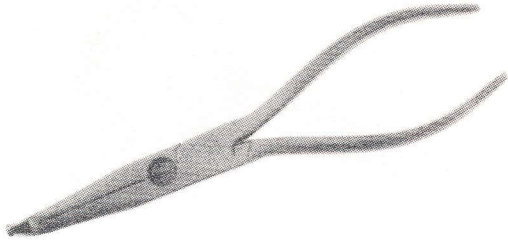

Piston pin circlip pliers

123

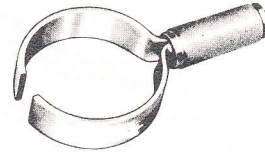

Piston ring compressor for 36hp  
A. For 40hp  
B. For 1500 and Porsche  
C. For 1600

124



Connecting rod bolt flaring chisel

126

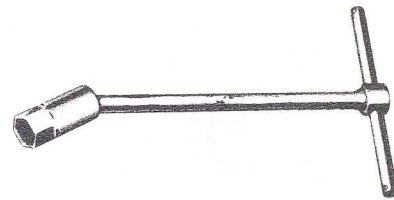

A. Fuel pump flex wrench, 14mm  
B. Fuel pump flex wrench, 13mm

130

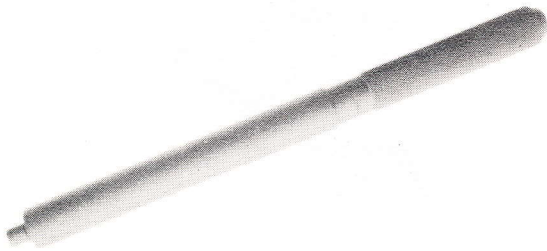

King pin drift, sedan  
A. For Transporter

131

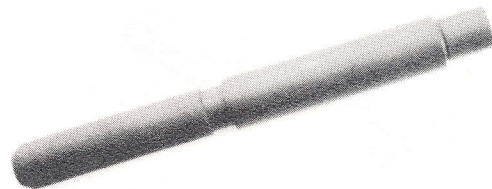

King pin bush drift, sedan  
A. For Transporter

133

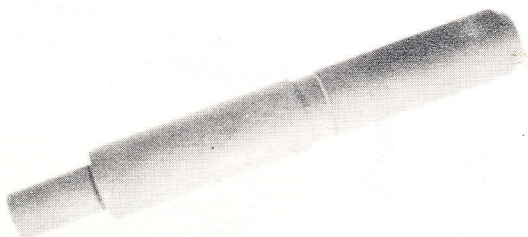

Torsion arm link pin drift, sedan  
A. For Transporter

156

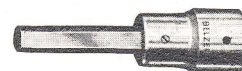

Connecting rod bolt allen-socket

157



Cylinder head bolt allen-socket for 36hp

159

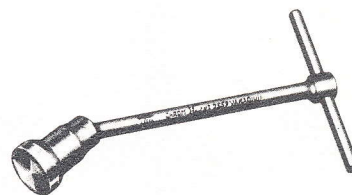

Oil pressure switch socket, 27mm  
A. 24mm for 40hp

161A



Transmission etc. circlip pliers



163

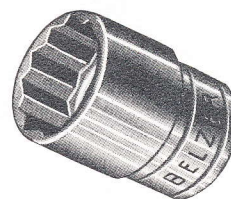

A. Rear axle socket, 36mm, 3/4" drive  
B. 36mm socket, 1/2" drive  
C. 36mm socket, impact, 1/2" drive

165

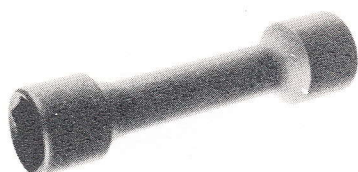

Cylinder head socket, 15mm, 1/2" drive

170

New



Improved design oil filler socket

172

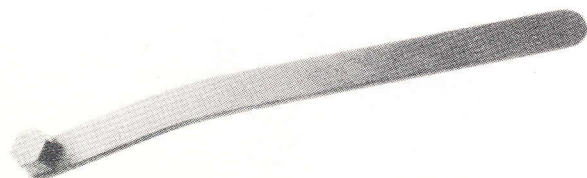

Drain plug wrench, 40hp, 17mm

L172



Drain plug socket, 40hp, 3/8" drive, 17mm

176

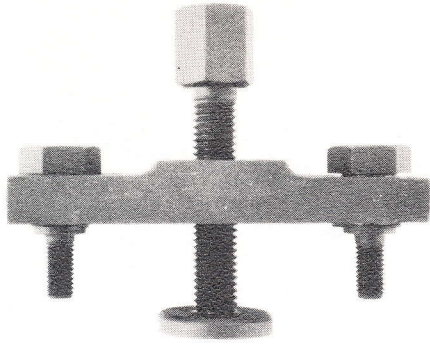

Fan puller for 1500-1600

178

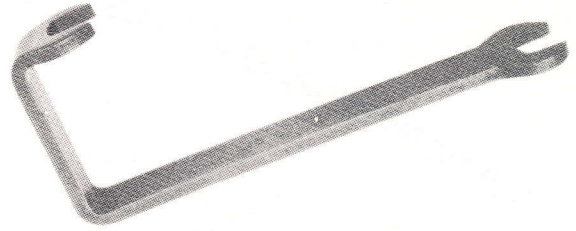

Carburetor flange bolt wrench, 1500-1600

201

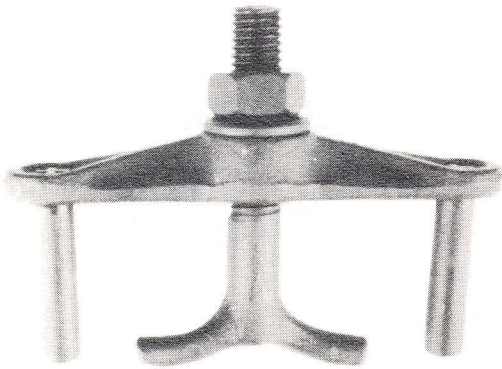

Oil pump puller

202F



Crankshaft thrust block, use with #4

202I

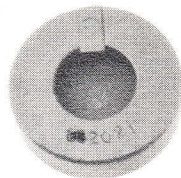

Front axle thrust block, sedan

202K



Rear axle and steering column thrust block

202M

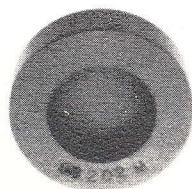

Front axle thrust block, transporter

203B

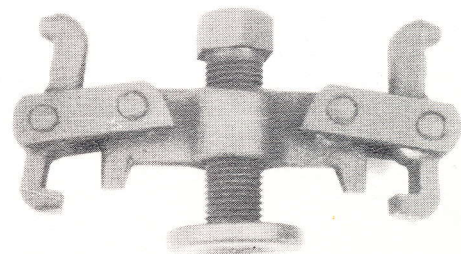

Crankshaft pulley puller



203D



Crankshaft thrust block, 36 & 40hp

204B

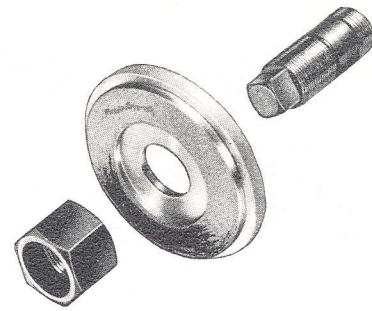

Crankshaft oil seal installer

207



Piston pin pilot drift, 36 & 40hp  
A. For 1500-1600

212A

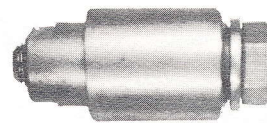

Piston pin bush puller and installer



L215

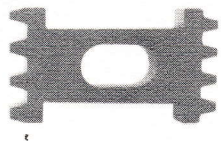

Flywheel holder, all models

L215C

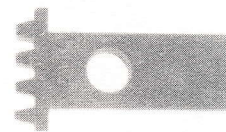

Flywheel holder, 1967 models

215

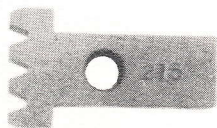

Flywheel holder, 36hp

215B  
C

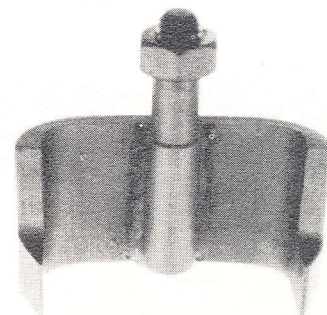

Flywheel holder, old models  
C. Flywheel holder, 1967 models

219



Clutch plate centering mandrel

222



Starter shaft bushing pilot mandrel

224

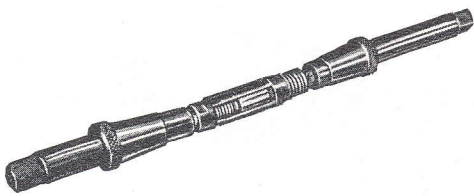

King pin bushing reamer, sedan, 18-21mm  
L. Spare blades, 18-21mm  
A. King pin bushing reamer, transporter, 21-24.5mm  
AL. Spare blades, 21-24.5mm

240A

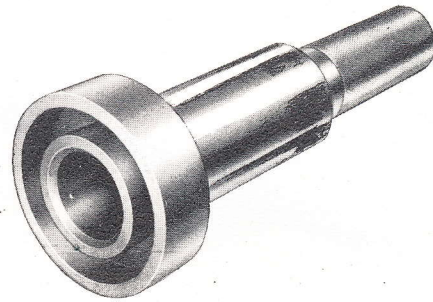

Rear axle tube bearing housing mandrel, et. al.

LL241

New

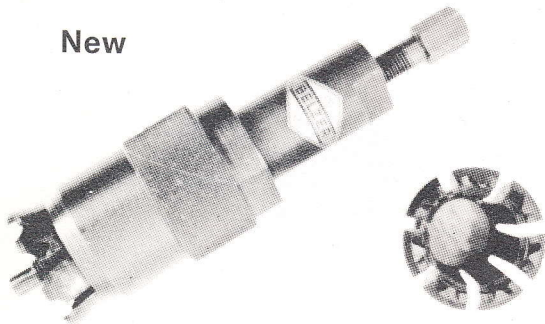

FANTASTIC rear axle bearing puller: guaranteed

L241A

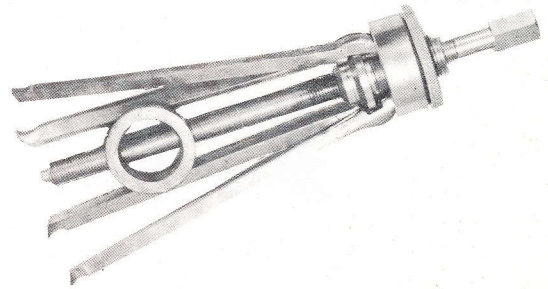

New rear axle bearing puller, including ring to adapt for front axle bearing.

243

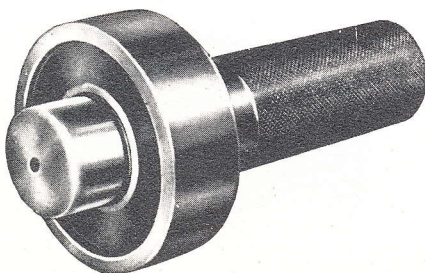

Driver for installing driven gear inner ball bearing in transporter reduction gear case & inner front wheel bearing outer ball race, transporter

244

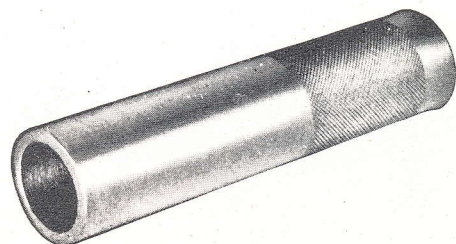

Driving sleeve for installing sedan inner front wheel bearing spacer and outer wheel bearing inner race

244B

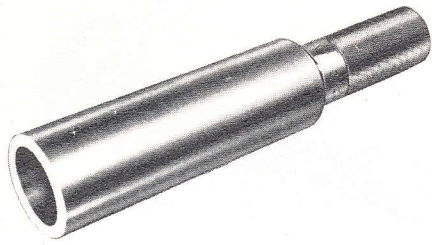

Rear axle bearing driver, et. al.

244C



Front wheel inner bearing driver

245A

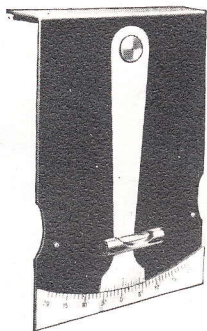

Caster and camber protractor  
L. Replacement float bubble

246



Starter shaft bush go-no-go gage



253

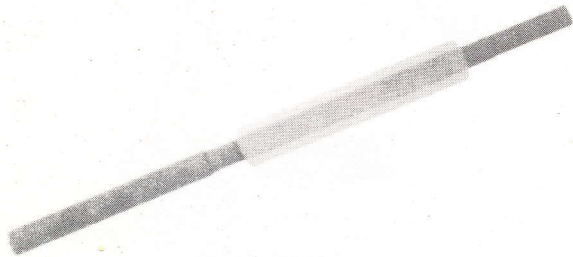

7mm Valve guide go-no-go gage  
A. 8mm Valve guide go-no-go gage

254A

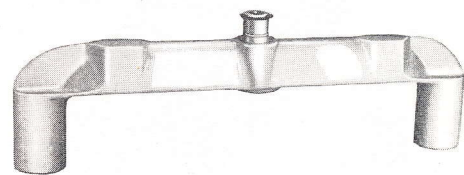

Clutch adjustment gage, magnetic

259

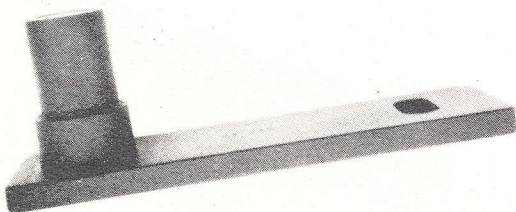

Torsion arm link offset gage, 36 & 40hp

295A

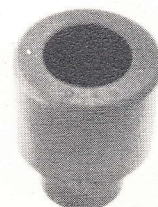

Thrust block for removing needle bearing from main drive shaft

266H

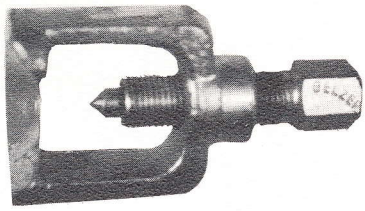

S. Tie rod end puller, sedan  
T. Tie rod end puller, transporter

270

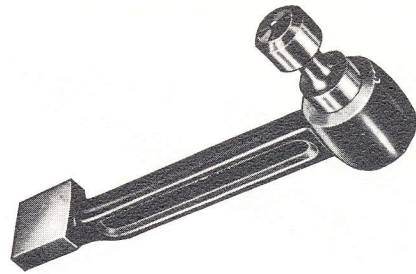

A. Torsion arm offset gage, sedan  
B. For Transporter  
C. For 1500 Transporter

277



Roller-type steering nut wrench

278A



Roller-type steering adjuster

282B-1

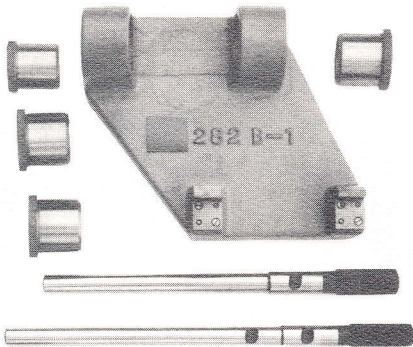

Test fixture for checking twist and parallel of torsion arms, old and late model sedans and transporters: enlarged set

287A



Differential housing length gage, 40hp

289D

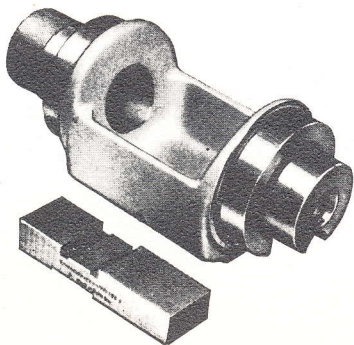

Transmission case mandrel gage, 40hp, in wood box

293

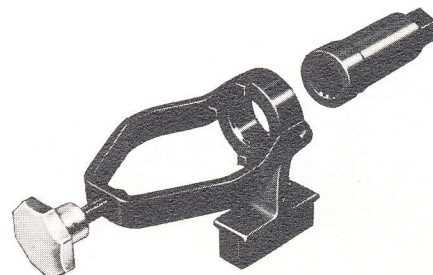

Drive pinion holding fixture, 40hp

294

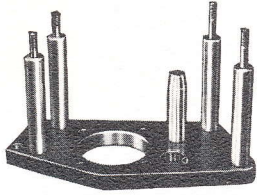

Gearshift selector forks adjusting device, synchro-mesh, 40hp

L 296



Heavy duty transmission removal tool, synchromesh transmission

297

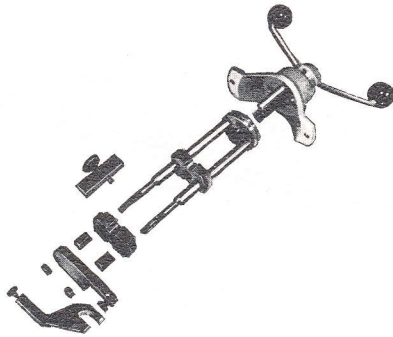

Ring gear backlash adjusting devices, 40hp, in wood box



298

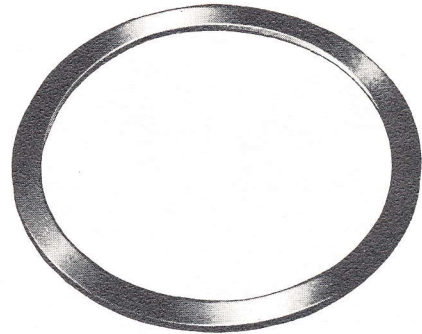

Ring gear adjusting ring gage, 40hp

299

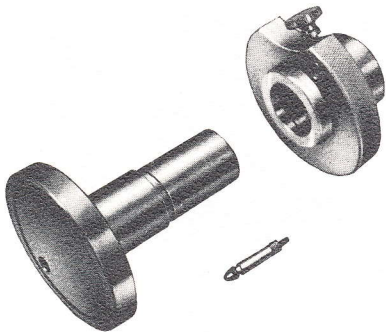

Drive pinion concave washer adjusting device, 40hp, in wood box

307A

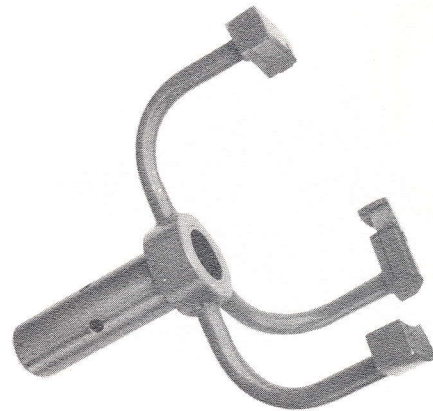

Stronger engine holding yoke for 36 & 40hp. 1500 & 1500-1600; fits into #313

L307-313

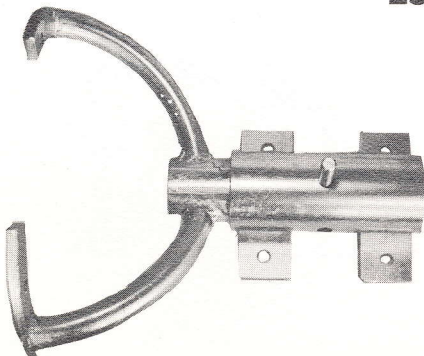

Engine holding assembly, economy model

L308

Heavy duty complete engine stand for all models including Porsche; adjustable height.

New

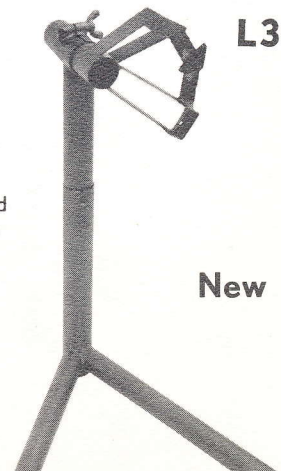

**309**

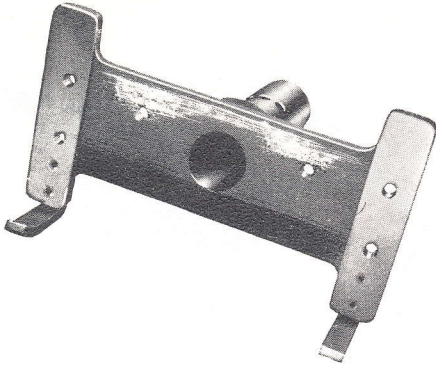

Front axle holding fixture; fits into #313 holder

**310A**

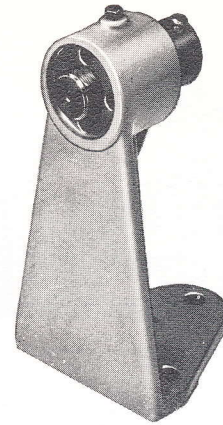

Crankshaft holding fixture

**311-1**

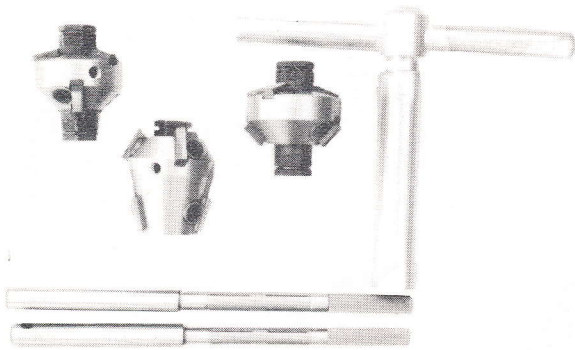

Complete seat cutter set for all models including 1500-1600, with adjustable pilots

**311**



2. Valve guide reamer, 7mm, 36hp  
3. Valve guide reamer, 8mm, 40hp

**311-12**



Valve lapper, 20mm rubber cup

**311**



16. Valve guide pilot, 7mm, 36hp  
17. Valve guide pilot, 8mm, 40hp

**311**

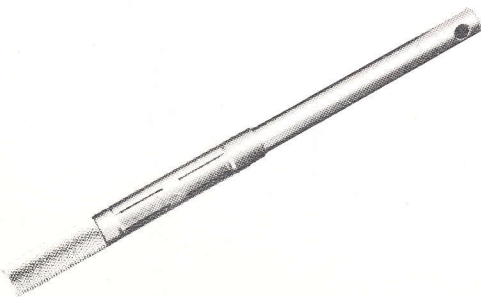

New adjustable valve guide pilot, 7mm  
A. 8mm

**311H**

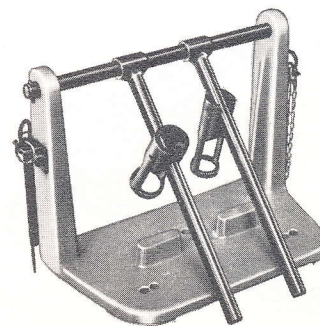

Valve spring compressing device

**L311K**

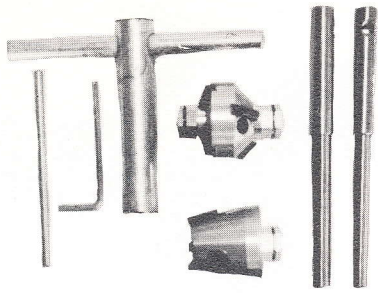

Fabulous valve seat cutter set including 7 and 8mm pilots; 15°, 45° and 75° — Blades and other heads on request

**313**

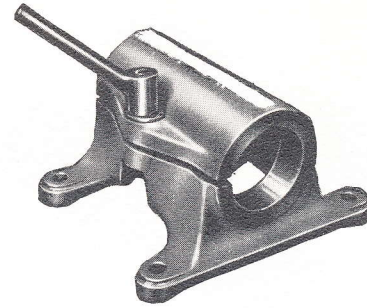

Base vise for holding yoke #307; fits on #308A

**328A**

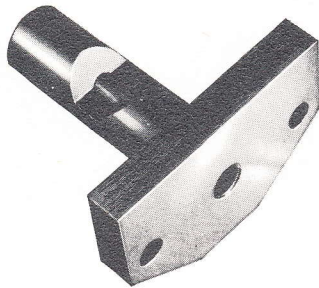

Fuel pump push rod gage, old models

**328B**

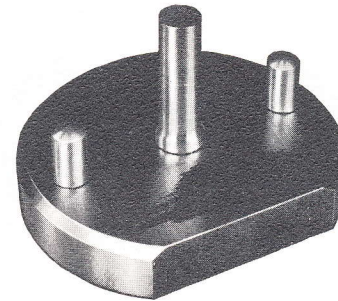

Fuel pump diaphragm gage, old models



**328C**

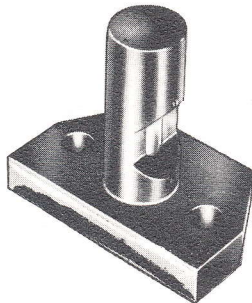

Fuel pump push rod gage, late models

**328D**

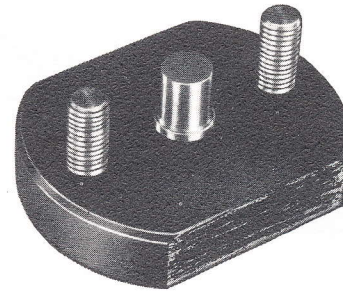

Fuel pump diaphragm gage, late models

**228A**

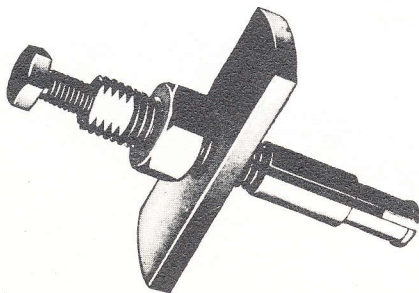

Puller for starter shaft bush and distributor drive pinion

**400**

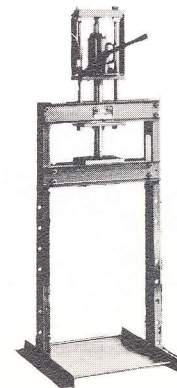

Hydraulic press, 12 ton, hand operated, for #400 series tools which are available on request

401

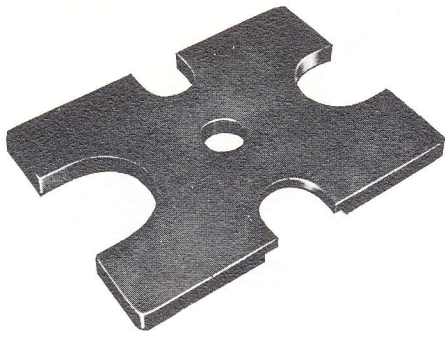

Thrust plate for use on #400 press with other press tools

402

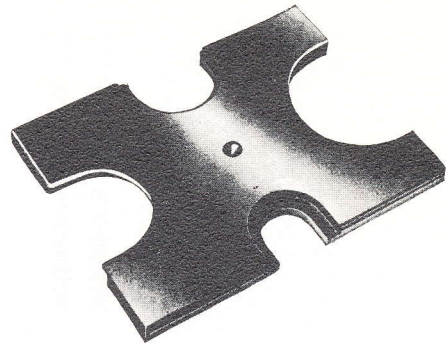

Thrust plate for various installations and extractions

405

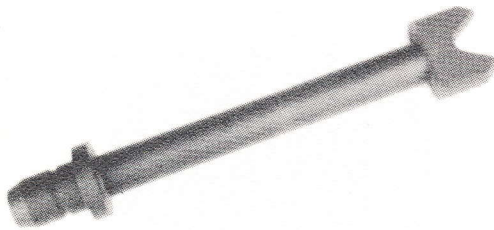

Special press punch for straightening, use with #406

406

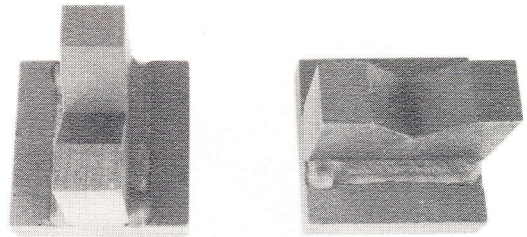

V-Blocks for pressing differential bearing from transmission case and general straightening

407

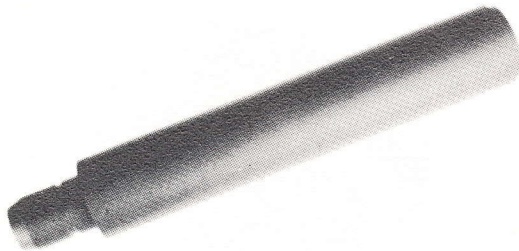

Mandrel for crank timing gear, axle shaft bearing housing, reduction gear case, 52mm outer front wheel bearing etc.

408

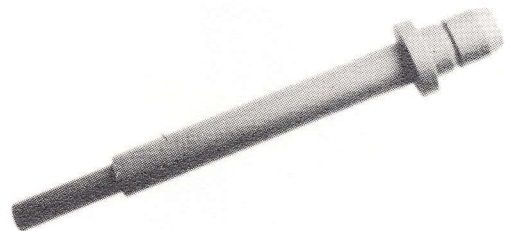

Mandrel for torsion arm link pin bush, starter shaft bush, clutch & brake pedal bush, piston pin bush, rear wheel oil seal etc.

409

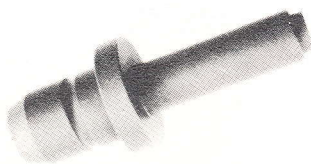

Mandrel for torsion arm link pin bush, transmission case bearings, reverse sliding gear bush, inner 59mm front wheel brg. etc.

410

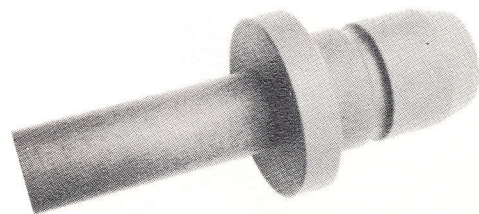

Mandrel for clutch pedal shaft bush, shock absorber bush, upper king pin, piston pin bush, lower torsion arm ball point etc.



411

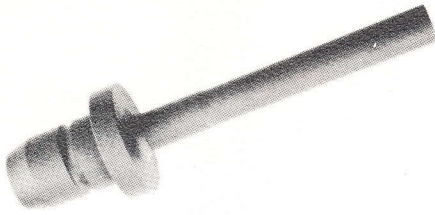

Mandrel for king pin, king pin bush, starter end plate bush, drive pinion roller bearing inner race, 52mm dia front wheel brg.

412



Thrust disc for various press operations

415

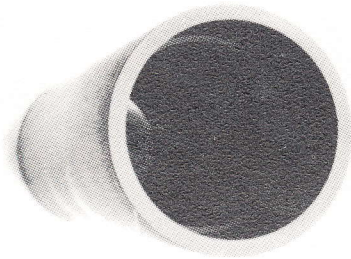

Tube for removing transmission case bearings, lower torsion arm ball joint, distributor drive gear, crankshaft timing gear etc.

416



Tube for installing drive pinion double ball bearing



417

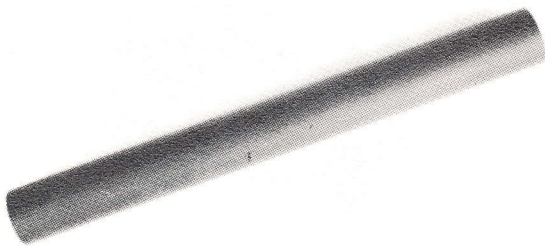

Tube for installing steering worm lower thrust bearing

418



Tube for removing starter shaft bush in end plate, removing sedan king pin, and installing torsion arm link pin bush

428

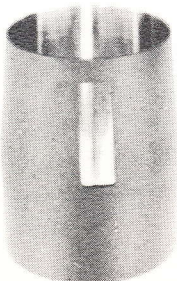

Tapered tube for centering drive gear retaining ring

431



Thrust block for removing sedan lower torsion arm ball point, synchromesh third gear on main shaft; for installing torsion arm link, brake pedal and clutch pedal bushes on sedan

**434**



Mandrel for removing torsion arm link pin bushes and drive pinion and main drive shaft; for installing sedan king pins and drive shaft bearing

**435**



Mandrel for removing clutch shaft bushes and clutch gear and fourth gear from main shaft

**436**



Guide pin for installing telescopic shock absorber bushing

**437**



Guide pin for installing lever type shock absorber and steering damper eye bushings

**441**

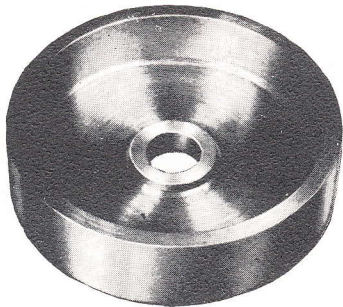

Base block for removing main drive shaft bearing etc.

**442**

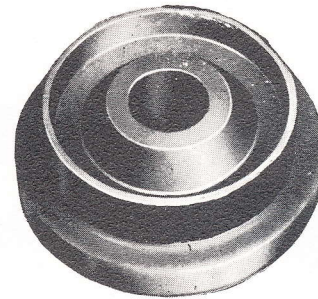

Thrust block for installing rear wheel bearing oil seal

**447F**



Disc for removing 1500 transporter outer race of outer front wheel bearing

**447H**



Disc for installing 1500 transporter outer race of outer front wheel bearing

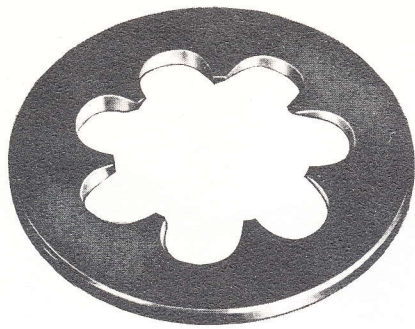

449

Ring for removing drive pinion inner race:  
 A. Klingelberg 7:31  
 B. Gleason 8:35  
 C. Gleason 7:31  
 D. Klingelberg 8:33  
 F. Ball bearing on Gleason 8:35

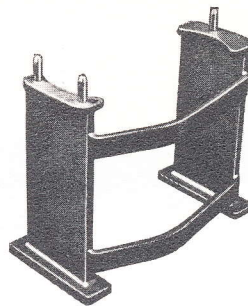

452

Gear carrier support

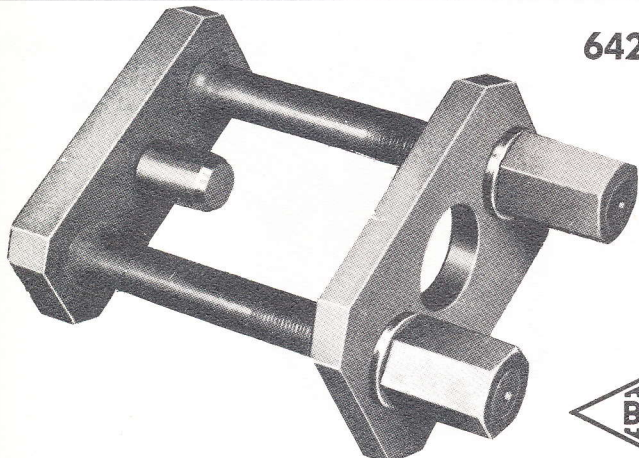

642

Swing lever shaft puller, transporter

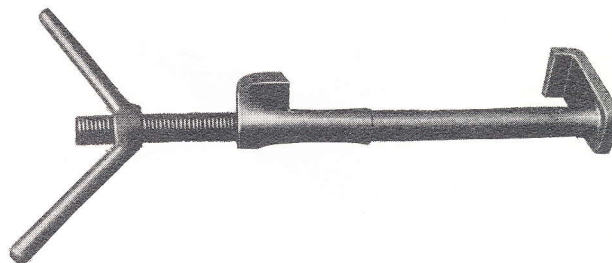

655

Torsion bar tensioner

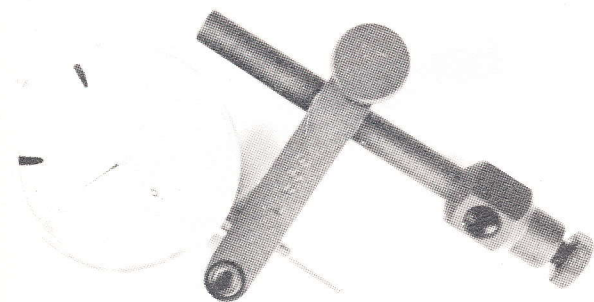

L 659

Dial indicator bracket for various jobs on 36hp, 40hp and 1500

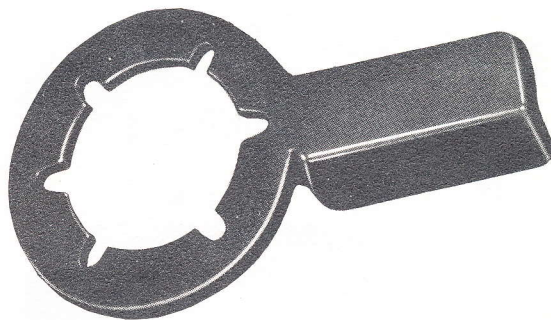

664

Differential housing holding fixture, old models  
 1. Differential housing holding fixture, late models

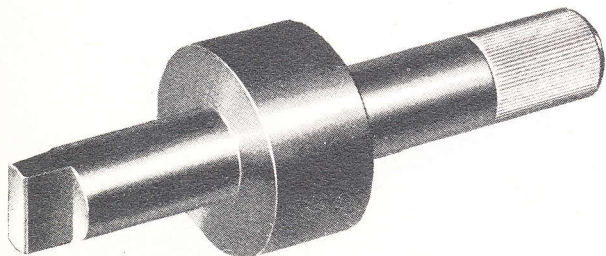

665

Oil pump centering pilot mandrel



667

Clutch cable adjusting star, 14mm

646/1



Carburetor discharge tube extractor

L667A

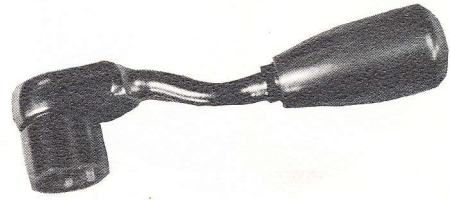

Clutch cable ratchet, 11 x 14mm

674

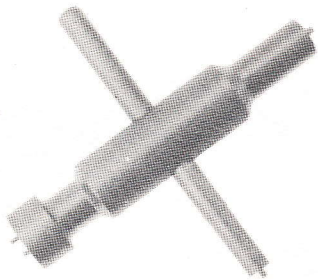

Dash switch, distributor cap suppressor plug and radio knob wrench

676

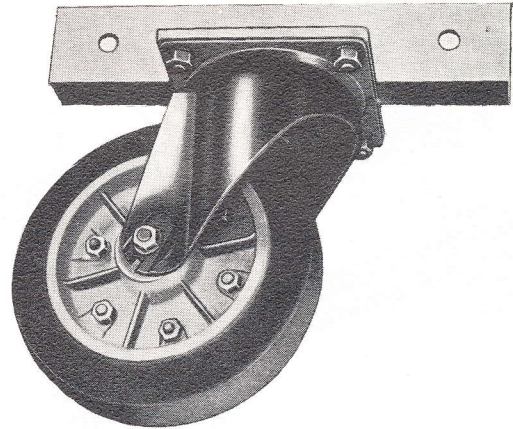

Caster and bracket for moving sedan with engine removed

L689

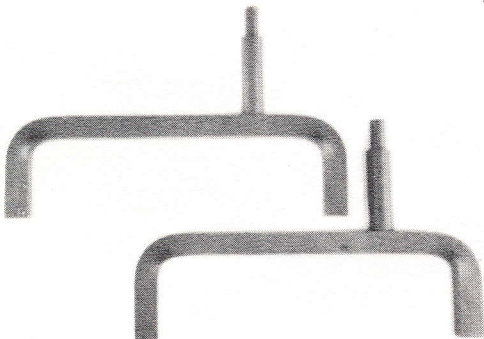

Cylinder head work bench mount

690



Rear axle shaft bearing installer

692

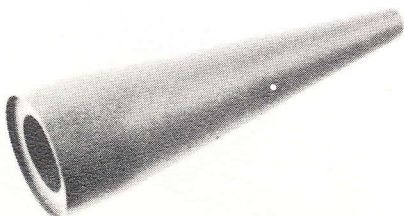

Ball joint spring clip installing sleeve

693

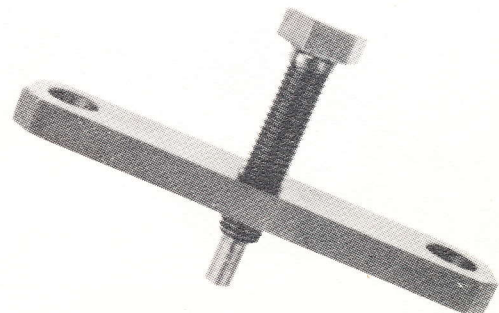

Transp. driven gear and rear axle puller

694

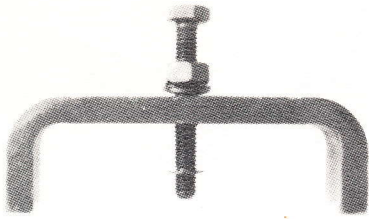

Transp. reduction gear sealing cap puller

753

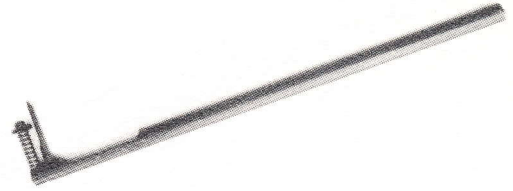

Brake lining wear gage

769

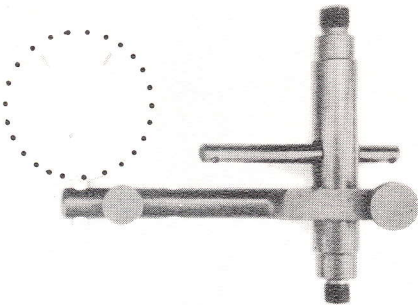

front axle dial gage holder for measuring play



901



Special double box wrench with only one deep offset: 10-32mm inclusive

902

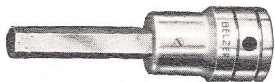

A. Allen socket, detachable bit, 3/8" drive: 3, 4, 5, 6, 8 & 10mm  
B. Allen socket, detachable bit, 1/2" drive: 6, 8, 10, 12, 14, 17 & 19mm

903

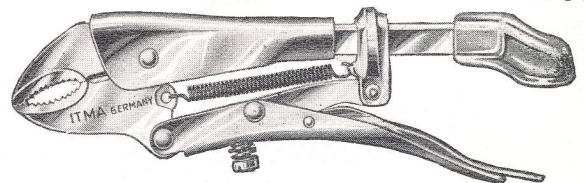

A. Automatic Lock-Grip wrench, round opening  
B. With flat jaws

R1

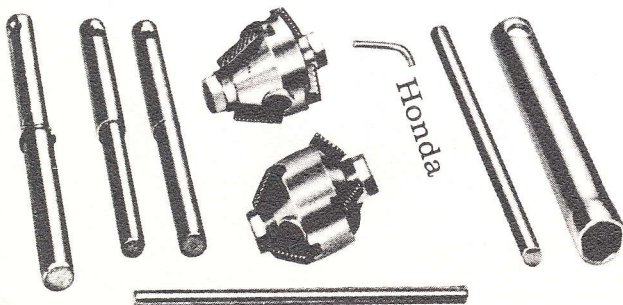

Renault valve seat cutter set, including 6, 7 & 8mm pilots; 15°, 30°, 45° and 60° ; also HONDA

TL

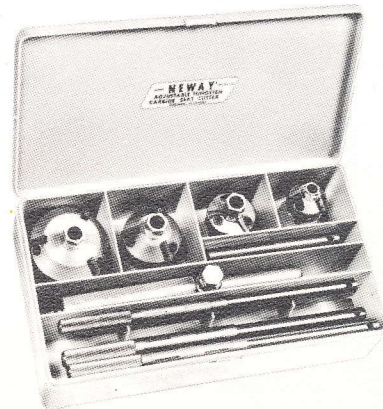

Fabulous seat cutter set for most European and American cars

P3

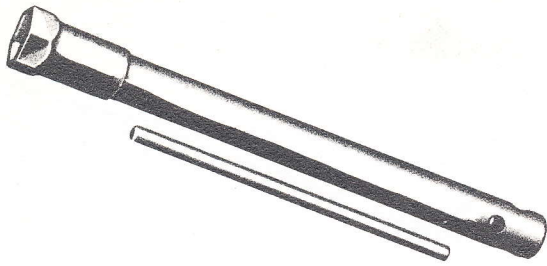

Spark plug wrench

P8A

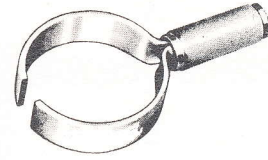

Piston ring compressor, 82.5mm

P10B

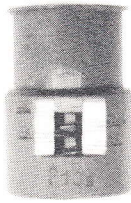

Valve Spring length gage, old and new models

P17

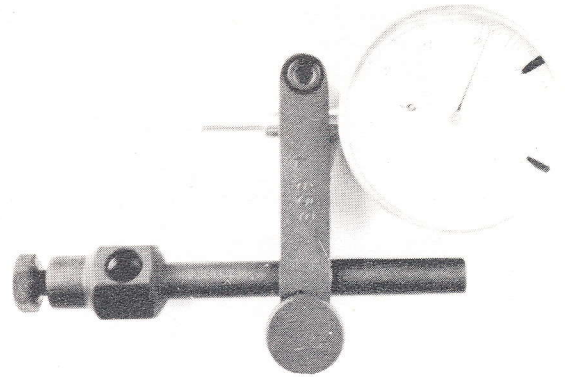

Crankshaft end play dial gage holder

P68

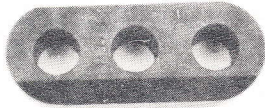

Holding plate for separating shift rods while adjusting

P77

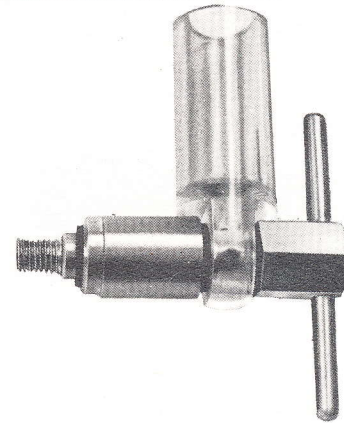

Float level gage, Zenith

P78

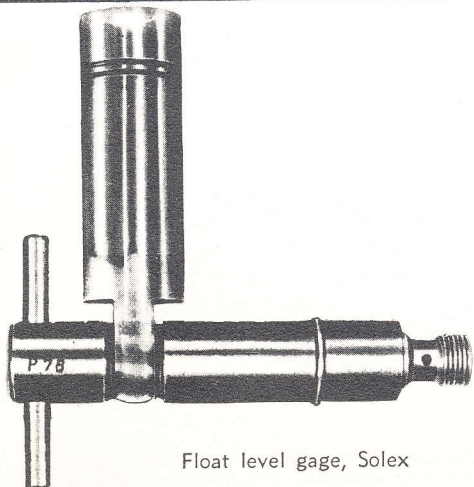

Float level gage, Solex

P100

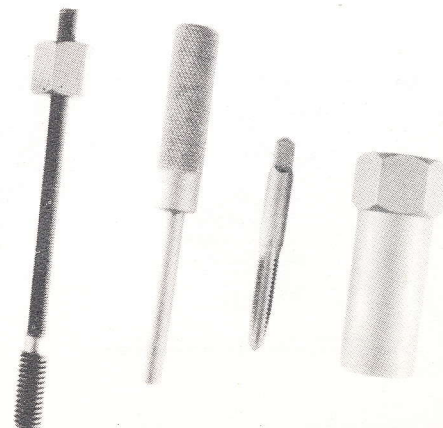

Valve Guide removal and installing kit

PORSCHE

P119

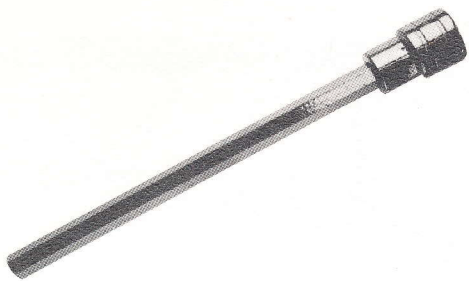

Cylinder head bolt socket 1/2" drive, all models including carrera

LP135

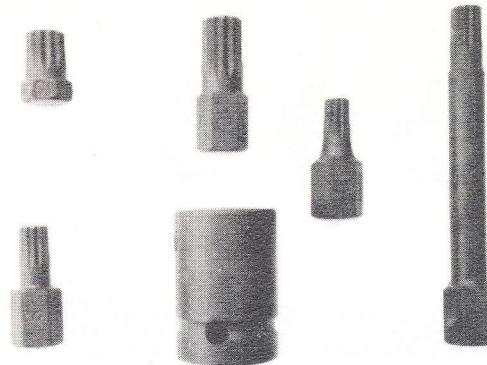

XZN Bit set for late model door hinge, flywheel bolts etc.

P226

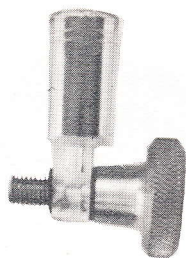

Float level gage, Weber

P



Magnetic spark plug socket, 3/8" drive



LP

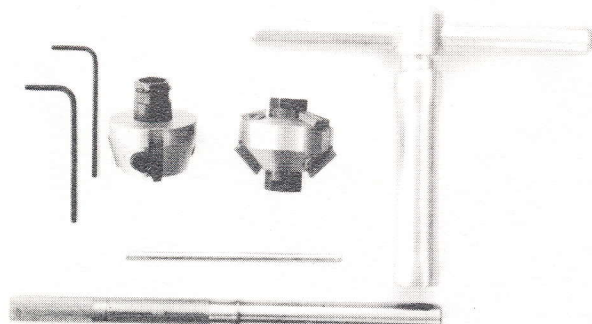

Porsche valve seat cutter set, complete with adjustable pilot

LPP



Porsche valve guide reamer, 10mm

PL

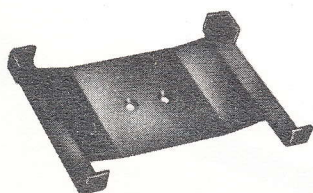

Engine supporting plate, use with #41 hydraulic jack

PLL



Belzer-Düsenlehre

Metric vernier jet gage, .1-3mm by .01mm

# MERCEDES

**MB1**

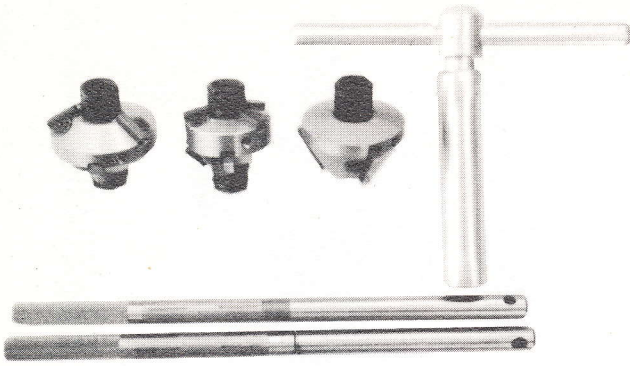

Mercedes seat cutter set, with expandable pilots

**MB2**

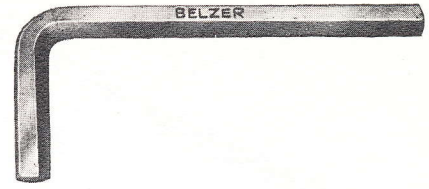

Mercedes gas tank plug wrench, 22mm

**MB3**

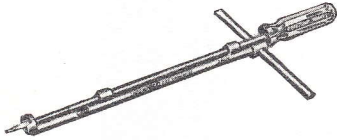

Mercedes valve adjusting wrench

**MB4**

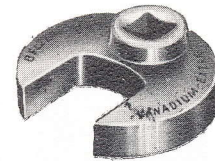

Mercedes valve adjusting crowfoot wrench, late model

**MB5**  
**6**



Mercedes allen socket, 5 or 6mm, 3/8" drive, 160mm long

**MB7**



Mercedes oil service wrench, 14mm allen x 17mm box

**MB8**

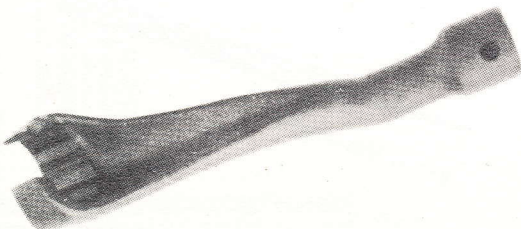

Mercedes injection manifold wrench, 17mm

**MB9**

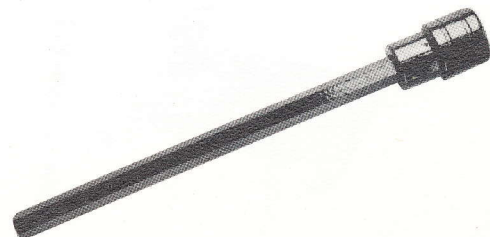

Mercedes cylinder head and rocker arm support allen socket, 1/2" drive, 200mm long



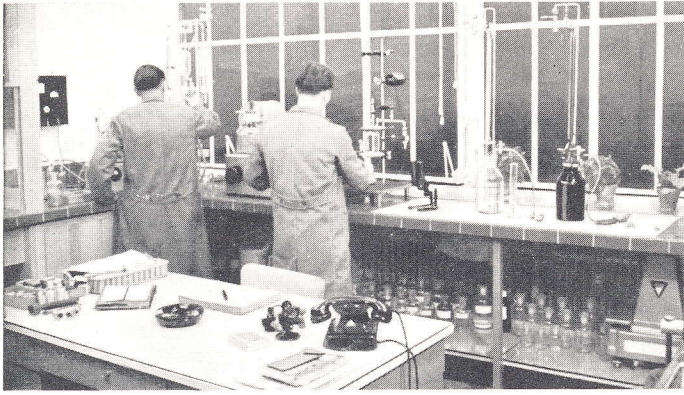

Das  
**BELZER-Labor**

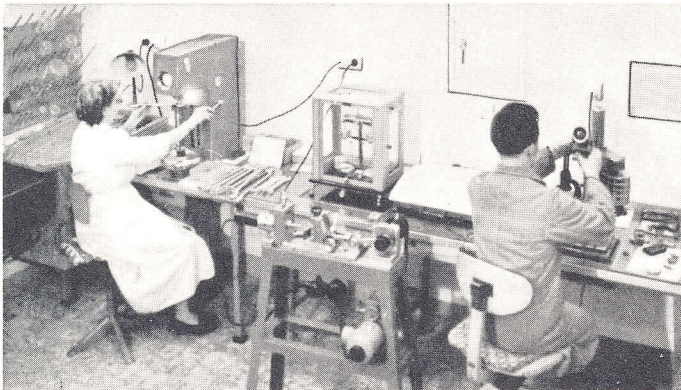
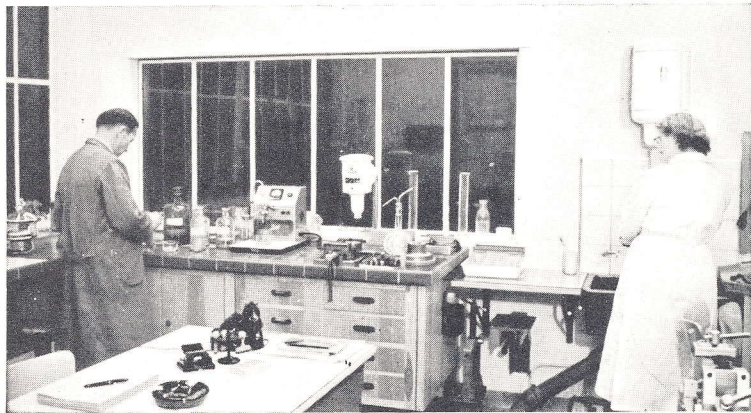

**Belzer Tools**

747 SEWARD STREET  
HOLLYWOOD, CALIF. 90038  
PHONE (213) 463-9377

Die Qualitäts-Prüfstelle  
des  
**BELZER-WERKES**

