

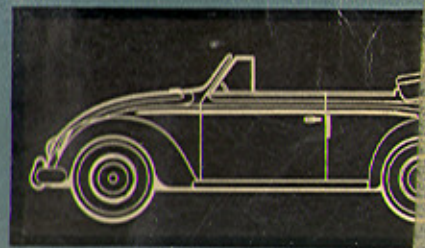

Instruction Manual



*Sedan and
Convertible*

Edition of August 1955

VOLKSWAGEN

Instruction Manual
Sedan and Convertible

Preface	3
Driver's Controls	5
Operating Instructions	9
Practical Driving	22
Winter Service	28
Lubrication	31
Wheels and Tires	39
Care of the Car	41
Maintenance	49
General Description	65
Technical Data	68
Maintenance Chart	71
Lubrication Chart	73
Index	74

VOLKSWAGENWERK GMBH · WOLFSBURG · GERMANY



It is our sincere desire that the excellent performance and economical operation of your VOLKSWAGEN will justify the confidence you have placed in our firm when purchasing this new car. Diligent effort has been made to turn out an efficient and reliable car. Now, it also depends on you to assure prolonged satisfaction in the running of the vehicle. All information contained in this indispensable handbook has passed the test of experience and practice of many years, and every attempt has been made to set out in full the requirements of proper operation, care and general maintenance of the VOLKSWAGEN. In addition, this book contains interesting specification details to familiarize you with the construction and operation of the VOLKSWAGEN.

In order to promote maximum efficiency, we particularly stress the importance of following the recommendations set forth in the ensuing pages. The intimate knowledge obtained in studying this manual will prove of great value in ensuring that the utmost service and satisfaction are being obtained from your VOLKSWAGEN.

Regular attention to proper lubrication and maintenance of your car is essential. An extensive network of VW Service Stations is available, and you will readily recognize such stations by the familiar blue VW SERVICE sign. These repair shops are in closest contact with the Volkswagenwerk through our field engineers, thus providing skillful and expert performance of any job to be done.

Each experienced motorist knows the value of preventive maintenance. The efforts in regard to care and maintenance will be amply rewarded in the long run.

And now go ahead and enjoy your ride!

VOLKSWAGENWERK GMBH



DRIVER'S CONTROLS

Are you familiar with the controls and instruments of your new VOLKSWAGEN? Just take a seat behind the wheel, make yourself comfortable, and get acquainted first with all the various levers, switches, and controls. Some of the features are familiar to you already, but here are the full details:

INSTRUMENTS:

- 1 Speedometer and mileage recorder
- 2 Warning light - Blue
Headlight upper beam
- 3 Warning light - Red
Generator and cooling system
- 4 Warning light - Green
Oil pressure
- 5 Warning light - Red
Direction indicators (two arrows)

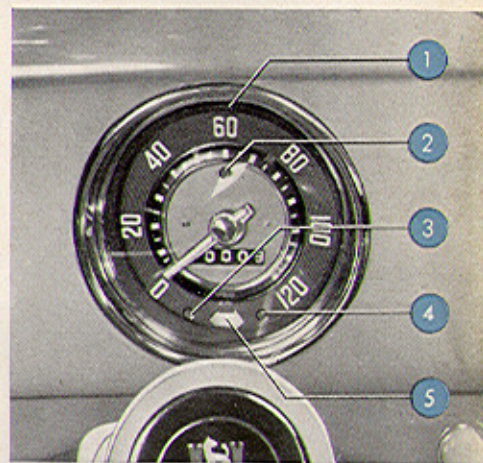

FOOT CONTROLS:

- 6 Headlight dimmer switch
- 7 Accelerator pedal
- 8 Brake pedal
- 9 Clutch pedal

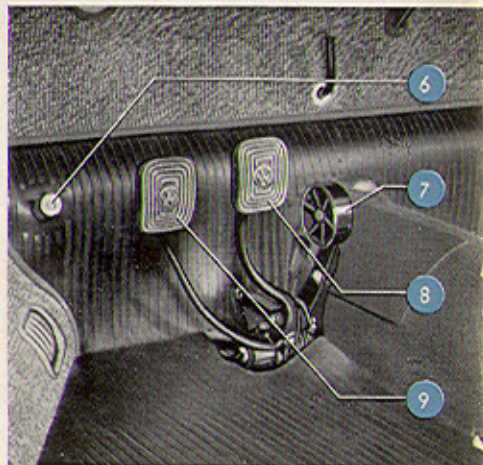

HAND CONTROLS:

- 10 Door inner handle
- 11 Headlight and instrument light switch
- 12 Windshield wiper switch
- 13 Choke control
- 14 Combined ignition and starting switch
- 15 Gearshift lever
- 16 Fuel tap
- 17 Hand brake lever
- 18 Heating control
- 19 Vent wing handle
- 20 Vent wing handle release button
- 21 Window regulator handle
- 22 Front hood lock control
- 23 Direction indicator lever
- 24 Horn button
- 25 Steering wheel

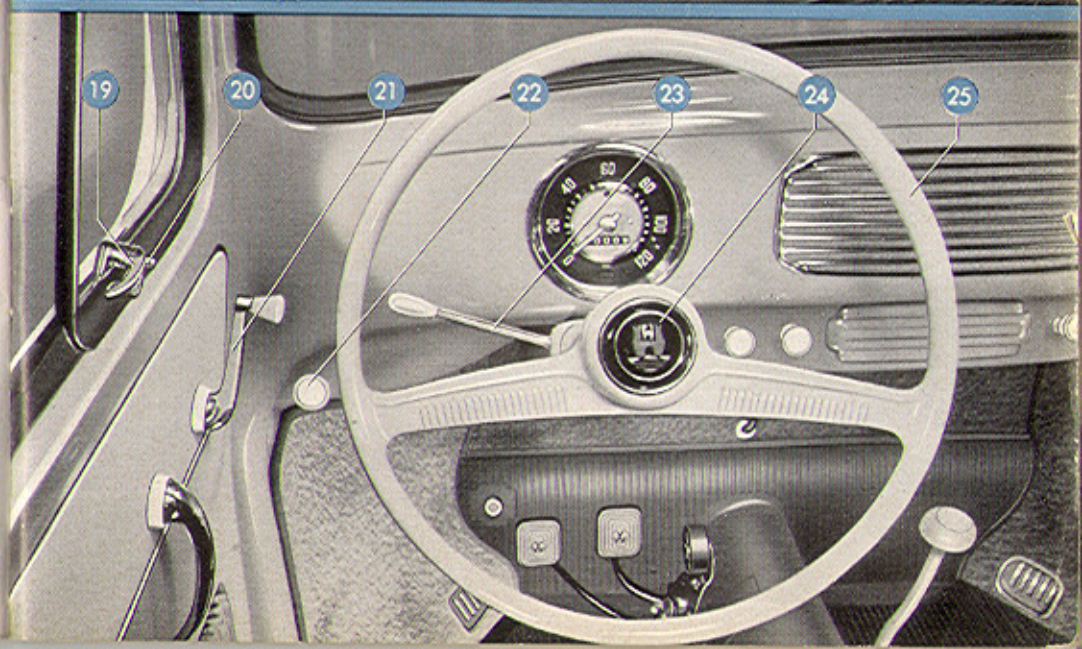
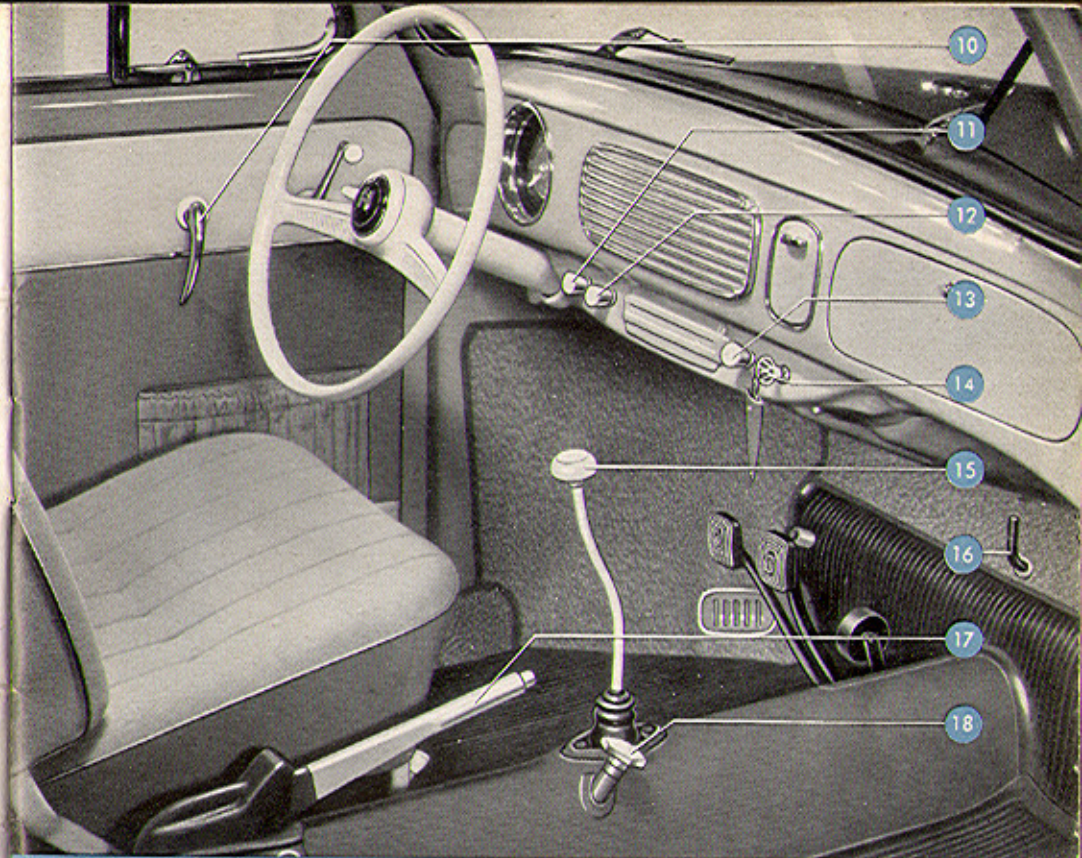

In the documents which come with your car you will find, among other data, details regarding the model, year of construction, and chassis and engine numbers of the vehicle. The Police or Traffic Department will see to it that the information on the papers corresponds exactly with that on your car.



The Model Detail Plate

is found in the location of the spare wheel, underneath the front hood.

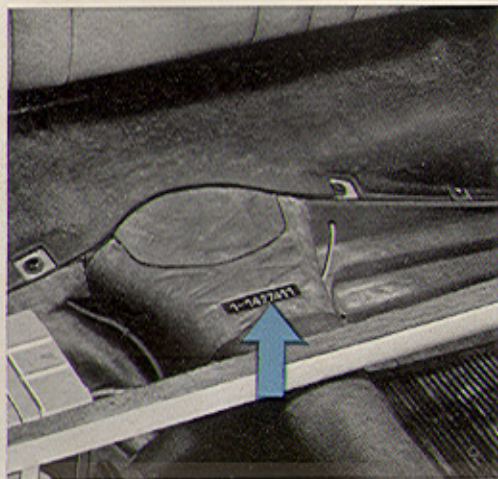

The Chassis Number

is found on the backbone of the chassis, underneath the rear seat.



Only one Key

is required to unlock the door, switch on the ignition, and operate the starting motor. It is advisable to write down the key number and keep it with the vehicle documents. In the event of having lost the key, just ask for a new one at your service station, giving the correct key number.



OPERATING INSTRUCTIONS

Before you drive away

please check

- engine oil level
- fan belt tension
- quantity of fuel in the tank
- tire pressures
- efficiency of brakes

and, if driving at night,

- the headlights

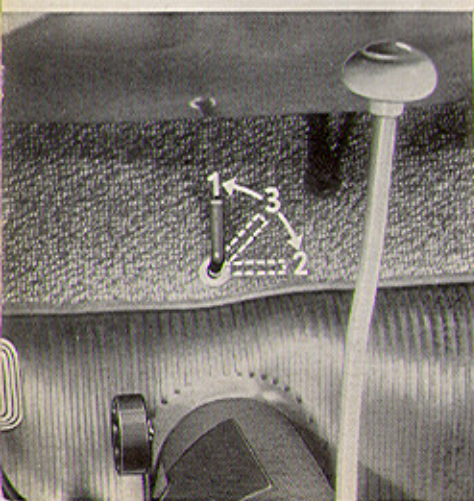
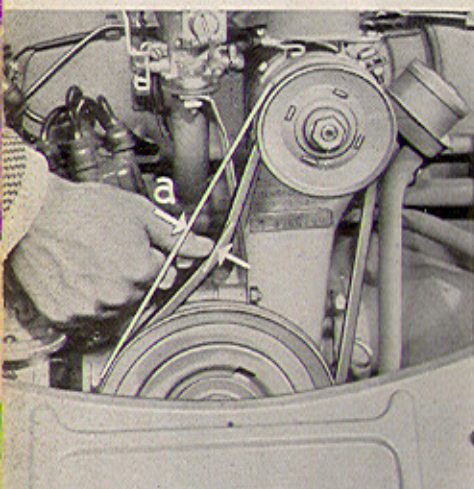
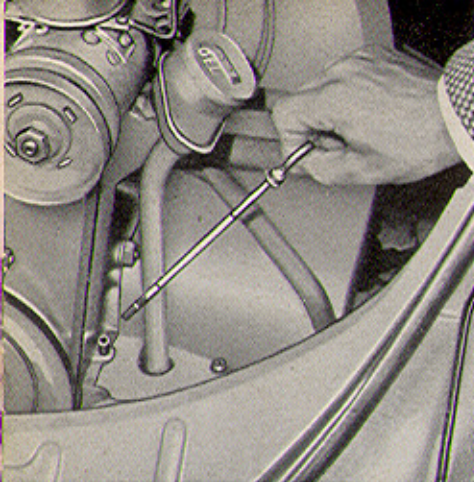

Engine Oil Level

The oil level should be checked with the engine at rest. The oil level is satisfactory when it is between the two marks on the oil level dipstick, but it should never be permitted to drop below the lower mark. To make an accurate check, it is best to wipe the dipstick with a clean rag before. Should it become necessary to top up the oil level, please remember the following hints:

Most oils marketed at present contain chemical ingredients to improve their lubricating qualities. However, oils of different origin behave differently when used as engine lubricants and should, therefore, not be mixed.

Select a HD oil from well-known and dependable brands right at the beginning, and stick to it!

It would be wrong to fill in HD oil and Regular oil at random, or even to mix these two types!

Fan Belt

The fan belt drives the generator and the cooling system of the engine. Perfect condition and correct tension of the belt insure its long life and adequate cooling of the engine. Checking is very simple: The belt, when slightly pressed with the thumb, must yield approximately 2 cm. (approx. 1 in.). No traces of excess use, such as frayed edges, should be perceptible.

a = 2 cm (approx. 1")

Fuel Tank

The tank has a capacity of 40 liters (10.5 U.S. gall., 8.8 Imp. gall.), sufficient for a drive of well over 500 kilometers (300 miles). Under normal conditions, the fuel tap should be set at position

Positions of fuel tap:
1 - Open, 2 - Reserve, 3 - Shut off.

"1", while the car is in operation. If the motor begins to "stutter", as a result of lack of fuel, just turn the tap to "2". A fuel reserve of 5 liters (1.3 U.S. gall., 1.1 Imp. gall.) will then last for a further drive of about 70 kilometers (45 miles). It is important to re-set the tap at position "1" when refilling the tank, otherwise there will be danger of running out of fuel on the road. The fuel supply is shut off when the lever is set half way (45°) between the two end positions.

The design of the VW Engine allows an operation on all proven trade-mark fuels. The good characteristics of trade-mark fuels, including gasoline-benzol blends, are evidenced by constant physical properties, sufficient anti-knock qualities and freedom from objectionable constituents.

The selection of a type of fuel is therefore left entirely to your discretion.

The Tires

deserve and require your special attention. The riding comfort and the road-holding of your VOLKSWAGEN will greatly depend on their condition. Maintaining correct tire pressure and avoiding driving abuses are the most important factors in obtaining maximum tire life. Make sure the tires are correctly inflated, at least once a week, using a reliable tire gauge.

Here are the recommended pressures: High speed driving conditions on long trips:

front 1.2 at. (17 lbs./sq. in.)
rear 1.6 at. (23 lbs./sq. in.)

Normal conditions:

Car occupied by 1 or 2 persons
front 1.1 at.
(16 lbs./sq. in.)
rear 1.4 at.
(20 lbs./sq. in.)

Car occupied by 3 to 5 persons
front 1.2 at.
(17 lbs./sq. in.)
rear 1.6 at.
(23 lbs./sq. in.)

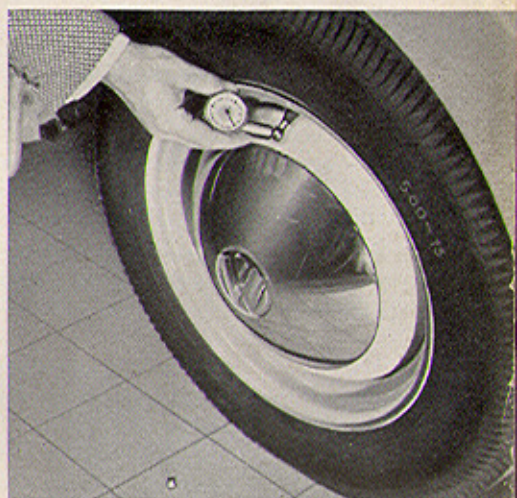

The Brakes

should be checked before the car starts on a trip by gradually pressing down on the brake pedal while the car is in motion to ascertain proper functioning.

Good Headlights

are the first requirement of safe car operation at night. The three positions of the lighting switch are as follows:

- 1 - Fully pushed in - Off
- 2 - Pulled out to first stop - Parking light, tail and licence plate lights
- 3 - Fully pulled out - Headlight upper or lower beams (depending on position of foot dimmer switch), tail and licence plate lights.

When pulling out the lighting switch knob either to the first or second stop, the instrument light is automatically turned on. By turning the knob, a variable degree of instrument lighting is obtained, turning the knob to extreme left turns out the light entirely. When checking the lighting system, do not forget the two stop lights which should light up when depressing the brake pedal.

Starting the Engine

is easy, because you are now familiar with the various controls and instruments. However, make sure that the gearshift lever is in neutral position before starting the engine.



The ignition key starting enables you to start the engine by merely turning the key. First the ignition is switched on by turning the key to the right. The red generator warning light and the green light for the oil pressure will light up. To start the engine, the key is pressed against a spring load and further turned clockwise until the starting motor operates. As soon as the engine fires, release pressure on key to disconnect starting motor.

In cold weather the transmission oil is apt to become congealed. It is, therefore, good practice to declutch until the engine fires. Thus you will save the battery and facilitate the operation of the starting motor. You will never encounter any difficulties when starting your engine in severe frost, if you observe the rule of using adequately thin engine oil.

To start the engine **when cold**, pull out the choke control knob and let the starting motor operate until the engine fires. Do not depress the gas pedal. As soon as the engine starts, slowly push in choke control knob (about half its travel) until the engine runs smoothly and evenly at fast idle speed without a tendency to stall.

This position of the choke control knob permits a quick moving off without any detriment to the engine. Neither will harm be done to the engine when you drive for a longer period in dense city traffic with the choke pulled out half its travel.

As the engine attains operating temperature, you will notice an increase in the idling speed. At the same time gradually push the choke control knob fully home. This position must be reached before you make use of the full engine power on a free road. If the engine does not start within ten seconds, just repeat the procedure a few times, allowing a short interval between each successive attempt, as the battery is being strained heavily by continuous starting motor operation.

To start the engine **when hot**, do not pull the choke control knob. **Slowly** depress gas pedal while letting the starting motor operate. Do not pump the gas pedal.

It is important to know that pumping the gas pedal makes a starting of the warm engine difficult and increases the fuel consumption.

Caution!

Be careful when starting the engine inside your garage. See to it that the door and windows are open so that the exhaust fumes can escape. They contain the colorless, tasteless and odorless, yet extremely poisonous carbon monoxide gas.

Driving Away

is extremely easy, if you observe the following:

- 1 - Press down the clutch pedal as far as possible. Keep it in that position.
- 2 - Shift to the first gear. Release the hand brake.
- 3 - Engage the clutch by gently removing your foot from the pedal, while simultaneously pressing down the gas pedal. The car rolls!
- 4 - Gradually increase the pressure on the gas pedal and remove your foot completely from the clutch pedal, as the clutch is now fully engaged.

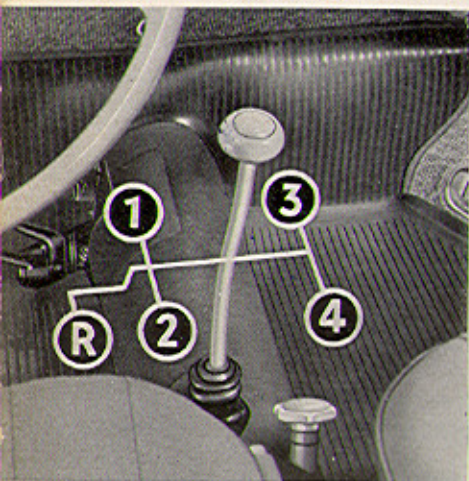

Shifting to second gear is equally simple

- 1 - Take your foot off the gas pedal, while simultaneously pressing down the clutch pedal.
- 2 - Shift gear lever into second position.
- 3 - Engage the clutch by taking your foot off the pedal gently and gradually and again step on the gas pedal.

You now know how to "shift gears", and may at will shift to third and fourth positions. You will have noticed by now that on each shifting operation the gas and clutch pedals are operated simultaneously, but in opposite directions. It is the coordination of these simultaneous operations that brings skill in shifting gears.

To engage the reverse gear, first press down the gear lever vertically, move it to the left and pull it towards the rear.

Shifting to Lower Gear

This is what you should do in close city traffic, or with sharp turns ahead of you, or when driving uphill.

With the De Luxe and Convertible

- 1 - Release gas pedal and depress clutch pedal.
- 2 - Shift to 3rd or 2nd gear respectively.
- 3 - Release clutch pedal and step on gas pedal simultaneously.

Of course, this goes much more quickly in actual operation than by describing it here. We do not want to bore you with a technical discourse, but it may be of interest to you to know that, when changing down, the synchromesh device assures meshing of the gears without clash, as the clutch of the lower speed is brought into synchronism so that both gears are turning at the same speed.

When shifting gears, it is absolutely necessary to fully depress the clutch pedal. Incomplete declutching makes gear shifting difficult and leads to rapid wear of the synchronizer stop rings.

The first gear is not provided with a synchronizing device, as the main drive shaft normally is not turning when the car is shifted into first.

Should it become necessary to shift from second to first, the two cogwheels of the lower gear should be brought to the same ratio of speed by momentarily depressing the gas pedal with the shift lever in neutral position to insure an easy and silent engaging of the gears.

With the Standard Model,

shifting to a lower gear is done as follows:

- 1 - Release gas pedal and depress clutch pedal.
- 2 - Place gearshift lever in neutral position.
- 3 - Release clutch pedal and depress gas pedal at the same time, the amount of this intermediate feeding of gas depending on the speed of the car.
- 4 - Depress clutch pedal and shift to lower gear.
- 5 - Release clutch pedal steadily and at the same time step on gas pedal.

After a short period of practice, you will take pleasure in the correct handling and shifting of the gears and obtain the utmost satisfaction from the efficient performance of your new VOLKSWAGEN! Under no circumstances should you be afraid to shift to lower gear, or try to avoid shifting occasionally by merely

letting the clutch "slip" in a partly disengaged position. Do not use clutch pedal as a foot-rest while driving your car.

Wait until the car is at a dead stop before engaging reverse.

Brakes

The brakes should be applied sparingly. The inexperienced driver can be recognized by the too frequent lighting-up of the stop light. By removing your foot from the gas pedal, the engine compression will serve as a brake, thus saving fuel and preventing premature wearing of tires and brakes. Don't drive too fast and then skid to a stop, but drive at a moderate speed, commensurate with the traffic, and your car will perform most economically. To press down the brakes suddenly can only be justified when danger is ahead.

Operate your brakes especially gently when the road is wet or covered with ice.

Sudden braking of the wheels will result in skidding of the car.

Here is one of the fundamental rules:

Use your brakes before, not while making a turn!

When driving downhill, make use of the braking capacity of the engine compression by shifting to that gear which you would use in driving uphill. You will save and preserve the brakes if you use them only to control the speed occasionally, and at the same time you will attain a higher degree of safety. The ignition must never be switched off when descending grades.

Stopping the Car

Take your foot off the gas pedal and operate the brakes gently. Shortly before the car comes to a full stop, depress the clutch pedal, place the gearshift lever in neutral position and release clutch pedal again. The engine continues to idle. If you wish to turn off the engine, merely switch the ignition key to the left.

The Front Seats

on the De Luxe Model allow an adjustment to suit individual requirements. Merely raise the adjusting lever and slide the seat either backward or forward

to the most convenient position. The seat rises as it moves forward, permitting short persons to sit higher.

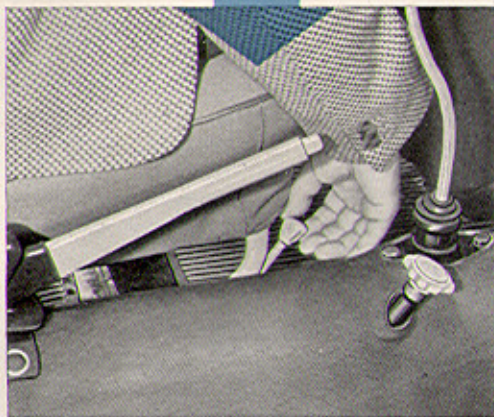

1 - normal 2 - backward 3 - forward

The rake of the front seat backs can be set at three positions by turning a lever.

On the Standard, loosen the wing nuts to move front seats forward or backward.



The Rear Seat Back

is held in place by a detachable rubber strap. Unhook the strap to tilt the seat back forward for loading or unloading luggage.

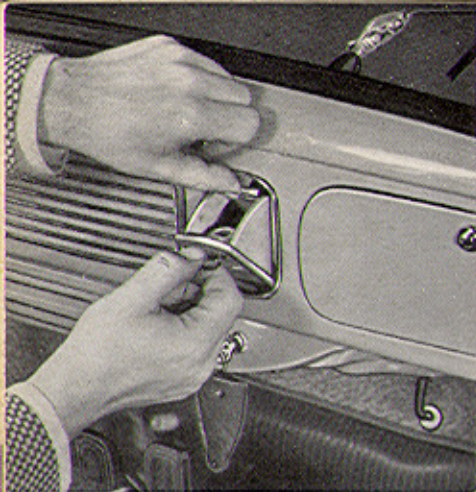

The Ash Receiver

in the instrument panel can be completely lifted out when slightly pulling up the retaining spring.

On the De Luxe Model and the Convertible, a second ash receiver is provided in the right-hand rear quarter trim panel. To empty, lift the retaining spring and pull the container out. To reinstall, insert the tongue at the bottom of the container into the slot of the ash receiver frame.



The Interior Lamp

is automatically operated by opening or closing either of the doors (De Luxe Model). As an added convenience the lamp may be operated by the manual three-position switch incorporated in the lamp fitting.

Positions of switch knob:

Lower	- On
Intermediate	- Off
Upper	- Door contacts

This allows the light to be turned off with the doors open.

The Convertible is equipped with a three-position tumbler switch below the instrument panel:

Left	- On
Intermediate	- Off
Right	- Door contacts

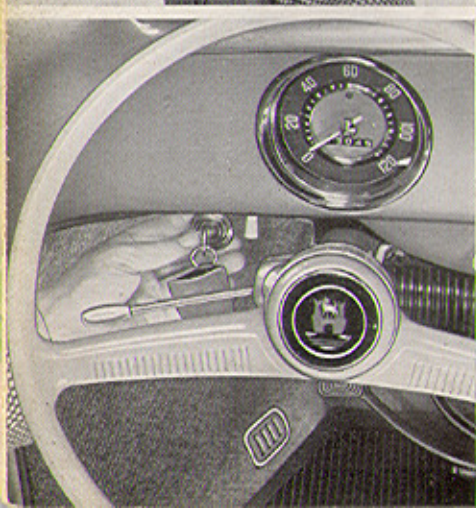

The Control Knob

for the front hood latch of the Convertible is equipped with a lock as an additional theft precaution. Thus, luggage, fuel and spare wheel are well protected with the top lowered. The

key — which also serves for locking the door and operating the combined ignition and starting switch — should be turned anticlockwise and removed immediately after the control knob has been pulled out. When closing the front hood, the control knob and the hood latch are locked automatically.

A different key is provided for the glove compartment lock on Convertibles.

The Jack

is secured in position adjacent to the spare wheel by means of a quick release clamping strap. Also accommodated under the front hood are the tools and the spare fan belt.

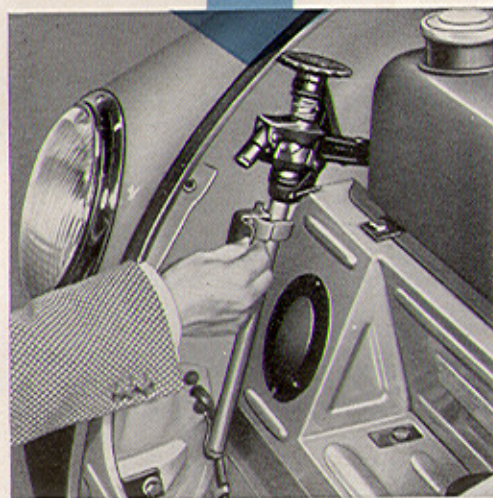

The Sun Roof

is free to slide by placing the locking lever to the left. It may be fixed in any desired position by merely moving the lever to the right. It is good practice, however, to fully open the roof prior to sliding it to the desired position. This will not only make the opened roof look better, but will also save the material by a proper folding.

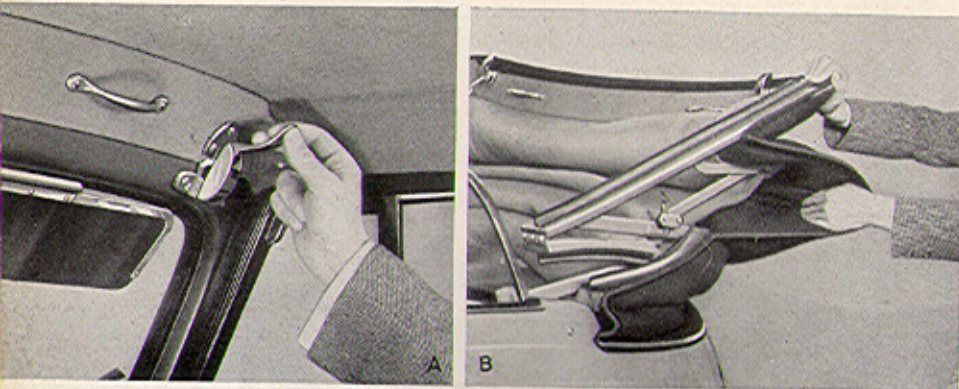

The Convertible Top

can easily be lowered and raised by one person. The service life of the top largely depends on the way the top is lowered and raised. That is why we would particularly stress the importance of following the recommendations put forward.

To Lower the Top

- 1 - Release the top (fig. A).
- 2 - Slightly lift the header and push the top toward the rear.
- 3 - Withdraw top cover from the linkages on both sides (fig. B).
- 4 - Push the top lining inward so that the linkages are free (fig. C).

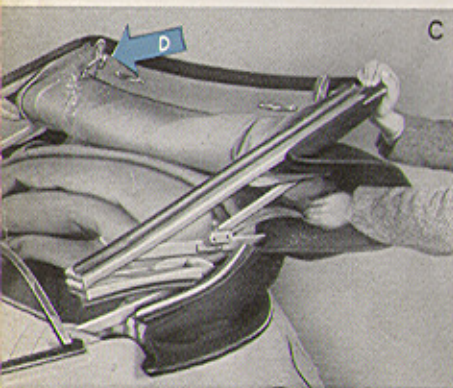

- 5 - Press down the top until the spring-loaded catches (one on each side) engage in the slots cut in the side rails (fig. E).

- 6 - Place the shells of the top locks over the lock guides and press down the levers (D).

- 7 - Install the top boot from the rear and secure it with the button fasteners. The top cover should be perfectly concealed by the boot, paying particular attention to the bottom part of the boot. The ornamental strip at the top cover edge should be visible.

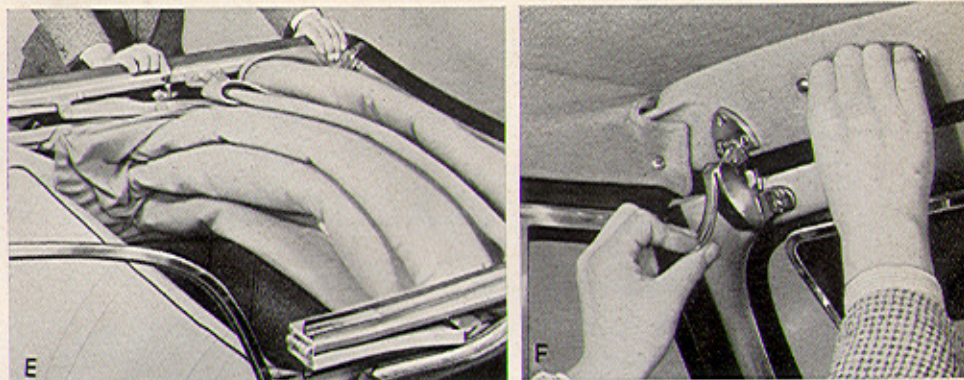

To Raise the Top

- 1 - Unsnap the button fasteners of the top boot and remove the boot. The boot is best stored in the luggage compartment, or under the front hood.
- 2 - Turn up the top lock levers.
- 3 - Press down the top and disengage the catches.
- 4 - Raise the top.
- 5 - Pull down the top by means of the hand grips until the lock guides engage in the channels of the brackets at the windshield frame.
- 6 - Place the top lock shells over the noses of the bracket and turn up the levers (fig. F).





PRACTICAL DRIVING

Breaking-in (running-in) Period

does not imply inconvenience as restrictions are not imposed on the speeds in the various gears.

Progressive refinements have raised the VW engine to its present predominant position and it is these refinements which allow an omission of breaking-in instructions. Your car may be operated right from the beginning at the full speeds recommended for the gears.

1st gear 0 — 25 km.p.h. (15 m.p.h.) 3rd gear 25 (15)— 75 km.p.h. (45 m.p.h.)
2nd gear 10 (6)— 50 km.p.h. (30 m.p.h.) Top gear 40 (25)—110 km.p.h. (68 m.p.h.)

The life of your car, its performance, and its operation will depend on your driving habit.

Maximum satisfaction in the running of your car will be assured by following the fundamental rules for driving an automobile:

Do not unnecessarily race the engine, no matter whether the car is stationary or in motion.

The new engine is not governed. Therefore, it is good practice to glance at the speedometer hand from time to time. The maximum permissible speeds in the gears are marked red on the speedometer dial.

Do not allow the engine to labor by driving at too low speeds.

Don't believe that your engine will be saved and preserved most when it is operated at low speeds only. You won't reduce the fuel consumption either. The engine requires air for cooling, which is only attained at an adequate number of revolutions. It is overloading and overheating that are harmful to the engine, but never high speed operation.

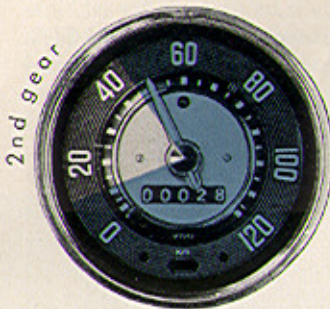
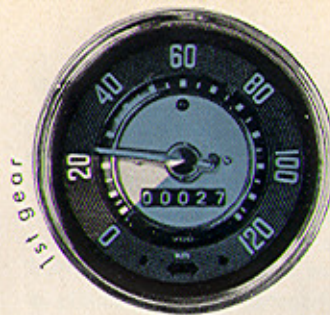

When driving uphill

always change gear as soon as the speed drops and the speedometer hand approaches the maximum speed limit of the next lower gear. Never allow the engine to labor in 4th gear, which is nearly an overdrive, and expect it to pick up speed on feeding more gas.

Economical operation

is one of the outstanding features of your car. However, whether or not a few extra miles will be yielded from each gallon will depend on the manner in which you handle the car and shift gears.

When accelerating,

step on the gas pedal slowly and only to such an extent as is necessary for reaching the desired speed. Depressing the gas pedal rapidly does not improve acceleration, but results in an increased fuel consumption.

Do not "pump" the gas pedal

unless circumstances require it. Even the small quantity of fuel additionally discharged by the accelerator pump each time the gas pedal is depressed results in a marked increase in the overall fuel consumption.

Operate your car smoothly and flexibly,

both when driving in city traffic and on main roads. Adapt the speed of the car to prevailing road and traffic conditions. A good driver accelerates the car moderately, slows down in time, and utilizes the braking power of the engine. Make use of the full acceleration capacity and the excellent brakes of your car only when circumstances require it.

How to drive at high speed without sacrificing fuel economy

When you have accelerated the car to the desired speed, slowly let the gas pedal return to the position which just maintains this speed. This practice is especially economical when driving on highways. If you attach particular importance not only to the economy of your car, but also to a fair average speed, it would prove of value to make a compromise in the choice of the cruising speed in the interest of fuel economy. The chart illustrates the manner in which fuel consumption increases in relation to the speed; it increases more rapidly at higher speeds.

Perhaps you are aware of the fact that air resistance is an obstacle for all high-speed vehicles. Due to the simple and sweeping lines of your VOLKSWAGEN, the air resistance is relatively low, but it should be remembered that high road speed always involves a greater fuel consumption.

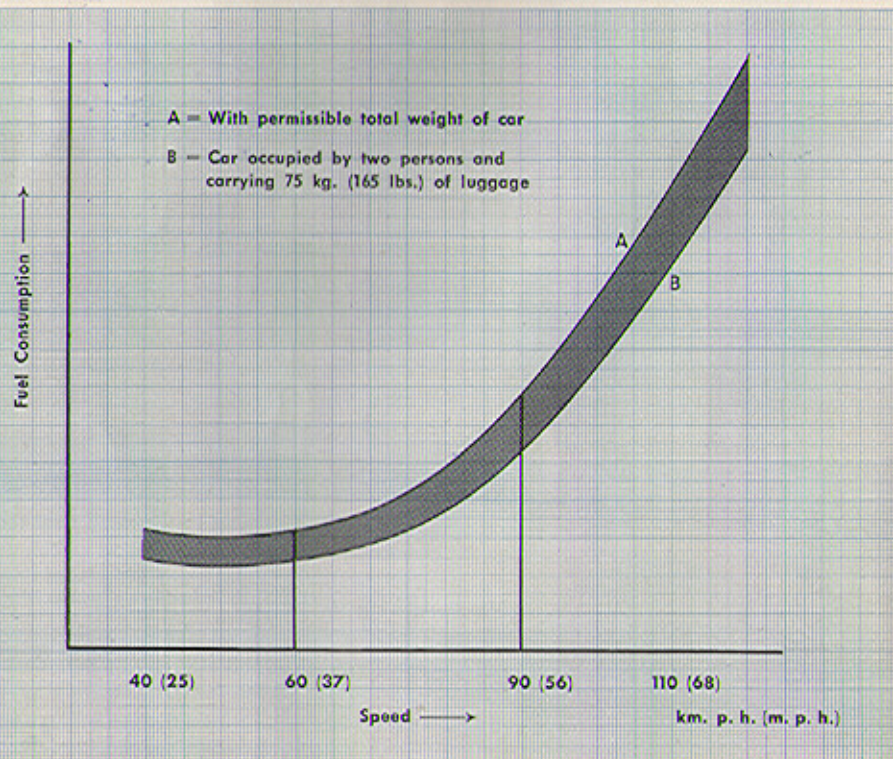

Watch the Road

closely while driving. As to the various manipulations of levers, switches and controls, you by now are able to operate them automatically. Furthermore, your VOLKSWAGEN on its own accord will "tell" you when it needs attention.

Generator and Cooling Red Light

are controlled simultaneously by a red light. The light will show when the ignition is turned on and when the engine is running at low speed. The light should go out when speed is increased.

Caution! If the lamp lights up while you are driving the car, the fan belt may be broken. Bring your car to a stop, and find out what is wrong, for when the belt is broken, the cooling is disrupted and the generator no longer charges.

Oil Pressure Green Light

The oil pressure of your car is as important as the oil level, which you have already checked. When the ignition is turned on, the Green Oil Pressure Lamp will light up. The light should go out when the engine is started and the oil pressure increases.

Caution! Should the light stay on during the ride, the chances are that the oil circulation has been interrupted, which means that the lubrication of the engine has ceased. Stop at once and check the level of the oil before you consult a Service Station. An occasional flashing of the lamp with the engine warm and at low speed does not indicate trouble, if the lamp goes out again as the speed increases.

Direction Indicators Red Arrows

The direction indicators lie outside the driver's view. However, the red lamp with the two arrows will serve as a reminder in case you have forgotten to turn the indicator off. The direction indicator switch can be operated without taking the hand off the steering wheel.

Headlights Blue Light

The upper beam of your headlights throws glare into the eyes of oncoming drivers. You know yourself how unpleasant and dangerous this is. For this reason, be considerate! The blue light will tell you when the upper beam is switched on. Just step on the dimmer switch to transfer the headlights from upper to lower beam and vice versa.

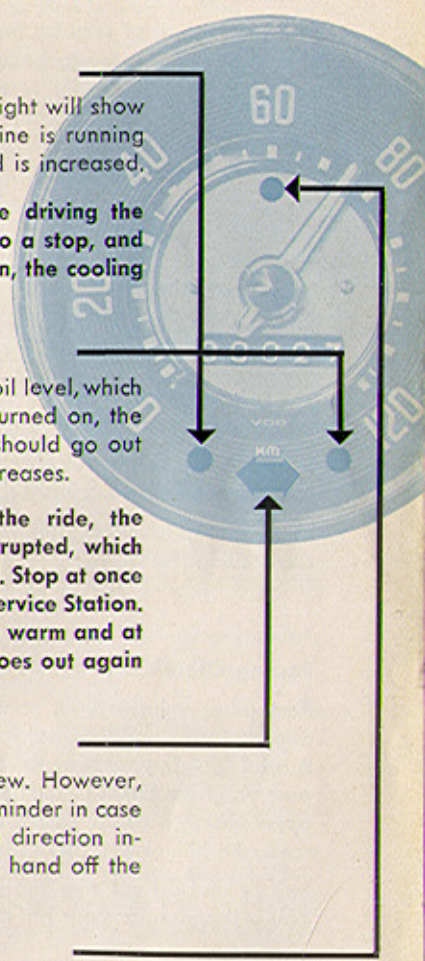

Safety First

Safety for yourself, and safety for others, this is what counts most! Your VOLKSWAGEN is a car that "hugs" the road in an excellent way, and does not roll when taking a turn. Your car has an extraordinary capacity for acceleration.

Yet, the feeling of security and safety which you will acquire after a few miles should not tempt you to become careless. Therefore, adjust the speed of your car to the conditions of road, traffic and weather, and always be ready to bring your car to a stop when it is necessary. Be particularly careful when driving on wet or icy roads, for even a VOLKSWAGEN is apt to skid when not driven carefully under such conditions.

Rear View Mirror

By turning the mirror to the vertical position, an additional adjustment is obtained to suit individual requirements.

The rear view mirror of the Convertible is adjustable to insure a perfect view no matter if the top is lowered or raised.

With the top in the raised position, turn the mirror holding rod down by 180° and push the mirror toward the windshield until the stop can be felt.

With the top lowered, pull the mirror back until the stop can be felt and turn up the holding rod by 180° .

Passing Other Cars

Pass other vehicles with consideration. Always be sure that the road is clear ahead of you, and look out for cars approaching you from the opposite direction. A brief look in your rear view mirror will tell you whether another car is about to pass you from behind. And here is another warning: Never try to pass a car when approaching a curve, where vision is not clear, and never pass a vehicle at the crest of a hill, or at crossroads! You never can tell what lies ahead of you!

Be fair and do not step on the gas pedal when another car tries to pass you. You will endanger your life and others!

Stopping Your Car Temporarily

When stopping your car in front of a traffic light or railroad crossing, do not wait for free passage with the clutch pedal pressed down and the gear lever in position! Shift to first gear shortly before moving on again, it will preserve the clutch!

Parking your Car

in a space between two other cars that are parked at the curb will be fun for you if you heed the following advice:

Stop your car even with the car in front of the space. Turn the steering wheel sharply to the right and back your car slowly into the gap.



When the front bumper of your car is even with the rear bumper of the car ahead of you, turn the steering wheel fully to the left, and back up further toward the curb.

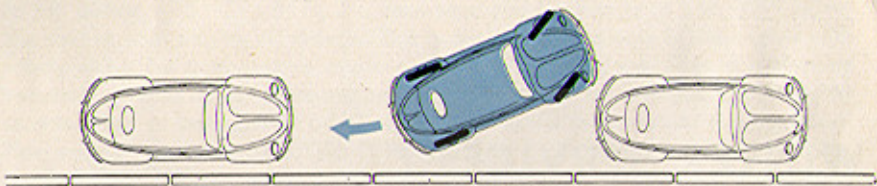

Now turn the steering wheel again to the right and pull up a little bit, until both ends of the car come as close to the curb as possible.

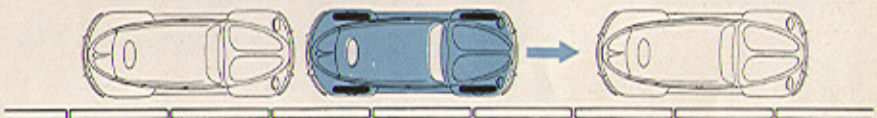

When parking on a steep grade, set the handbrake so as to keep the car from rolling. As a precautionary measure, it is advisable to engage first or reverse gear in addition to the handbrake. And do not forget to take the key out of the ignition switch before you leave your car!

Do not forget to shut the fuel tap when parking on a grade with the rear end of the car downwards.

Prior to locking the left-hand door secure the right door by pushing the inside door handle forward. The vent wing handle is locked by turning it to the position where the push button is heard to spring out.



WINTER SERVICE

In **Winter** there are two advantageous features of your VOLKSWAGEN that you will appreciate most:

Air Cooling and Heating

You may expose your car to bitter cold without fear:— its air-cooled engine will always be ready to start! You will drive in warm comfort, well protected from drafts and from sleet and snow, while a current of warm air will keep your windshield free from condensation and frost, permitting you a clear view. The increased stress that your car has to stand in winter because of frost and dampness can be easily dealt with if you observe the recommendations presented in this section.

Never attempt to influence the cooling and heating of your car in winter by covering the air intake slots below the rear window. This would be harmful to the engine, as the drawing in of fresh air for the carburetor and the heating would be seriously affected. The intake of cooling air is already efficiently controlled by the thermostat.

The Warm Air Heating

of your car can be regulated by a rotary knob situated adjacent to the gear lever:

- Anti-clockwise - On (A)
- Clockwise - Off (Z)

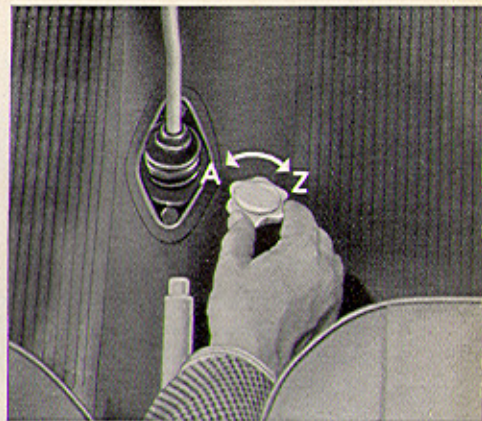

Engine Oil

SAE 20/20W oil will not congeal in cold weather down to -15°C ($+5^{\circ}\text{F}$) and will permit easy starting of the engine. If, however, temperatures are expected to fall below -15°C ($+5^{\circ}\text{F}$), it is recommended to change to SAE 10 W oil at the next regular engine oil change. This grade oil may remain in the engine with safety when the temperature again rises to a higher range. Should it become necessary to add oil in the period between two regular oil changes, SAE 10 W oil may be used at lasting frost and SAE 20 oil when the temperature average rises. This means that the grades SAE 10 W and SAE 20/20 W can be mixed without involving any disadvantages, but be sure to use always the same brand and type of engine oil.

In cold weather, allow the engine to idle for half a minute before driving to insure correct oil circulation.

Don't race the engine in severe frost to obtain a quick start.

Only if your car is mainly operated for short distances **during cold weather** it is recommended to have the oil changed at more frequent intervals, say every 2500 km (1500 miles), using the right HD oil. In the warmer season, oil changes in addition to those laid down in the Lubrication Chart are unnecessary and uneconomical.

Transmission Oil

serves its purpose in any season and needs, for this reason, no particular attention or change. If your car is a Standard Model, you will find from experience that during the winter months shifting to higher gears must be done with shorter pauses, until the transmission oil has warmed up, because the stiff oil has a higher braking effect on the gears.

The Chassis

is particularly exposed to the cold and wet weather in winter. For this reason it will be necessary, and only logical, to adhere strictly to our instructions for lubrication. If, in addition, you will spray the bottom of the car with a special chassis oil, as a protection against rusting, you will have prolonged the life of your car.

The Brakes

of all automobiles are exposed more or less to splashing water that in winter is apt to freeze in the brake drums. Therefore, when parking your car, do not set the handbrake, but shift to the first or to the reverse gear instead. At the beginning of the cold season, the conduit tubes of the brake cables should be thoroughly lubricated with anti-freeze lubrication grease. Do not use just any car-lubricant, but get the right one at any VOLKSWAGEN Service Station!

Tires

Worn off tires are apt to cause trouble in winter. To assure a safe operation, replace them in time to meet the special requirements in winter, so-called M + S tires are available. These special-tread tires are designed to give a better grip on mud and snow. They are either used on the rear wheels only or on all four wheels. However, during the rest of the year you should rather use the usual tires.

Non-Skid Chains

You will need non-skid chains only when the roads are covered with snow. Without such chains, the rear wheels of your car are apt to spin, and applying the brakes may result in the car skidding. Have the non-skid chains adjusted to the wheels, if you wish to avoid loss of time and inconveniences later on!

When driving on long stretches that are free from snow, the chains should be removed to prevent excessive wear of both chains and tires.

The Battery

has to meet higher requirements in winter than in warmer seasons due to the increased consumption of current when starting engine and using the lights at night. Besides this it is a characteristic feature of any battery that its efficiency decreases at lower temperature.

Therefore, have your battery checked regularly, and you will never encounter any starting difficulties.

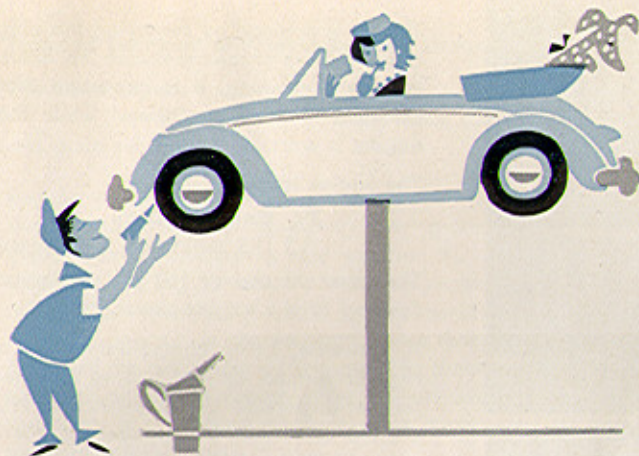

LUBRICATION

Proper Lubrication is of Vital Importance to Your Volkswagen

The extra time spent in following these recommendations will be amply rewarded in the long run by your car's efficient performance. It is up to you to maintain the standard of safety offered by your VOLKSWAGEN, and to insure the long life and good service which you have the right to expect from this highly economical car!

To lubricate correctly means to lubricate amply and at prescribed intervals!

Therefore, do not shy at the work connected with the regular lubrication service. A Lubrication Chart can be found on page 73, indicating the respective mileages at which to lubricate.

Our Service Policy makes it possible for you to have your VOLKSWAGEN lubricated at our workshops by skilled hands, with the best available lubricants, at a low cost and in a minimum of time. You really cannot afford to miss this opportunity!

Engine Oil Change

The change of oil at prescribed intervals is necessary even if the very best trademark oils are used. Diluted and dirty oil in your engine simply means a greater strain and a shorter period of life for your engine. On the other hand, provided that HD oil is used, it is unnecessary and uneconomical to change the oil more frequently than called for in the Lubrication Chart.

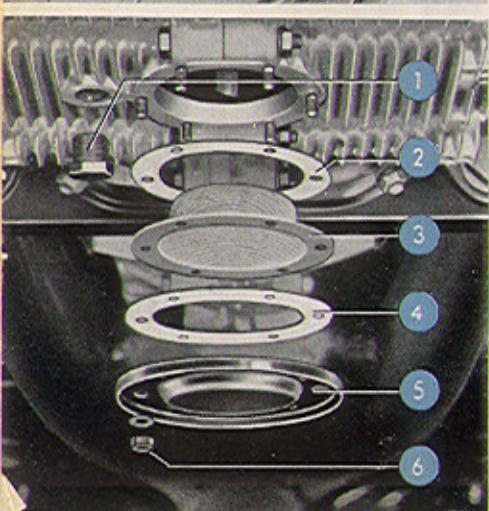
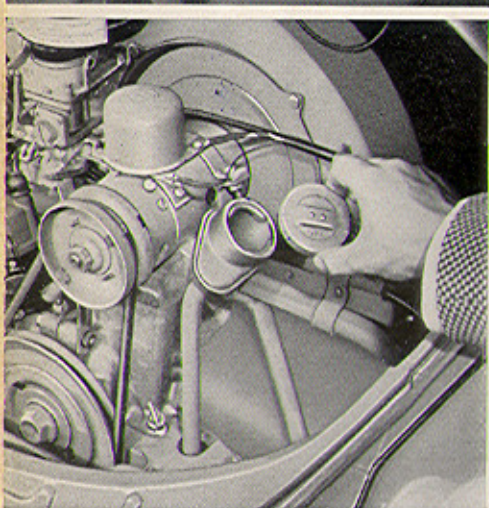
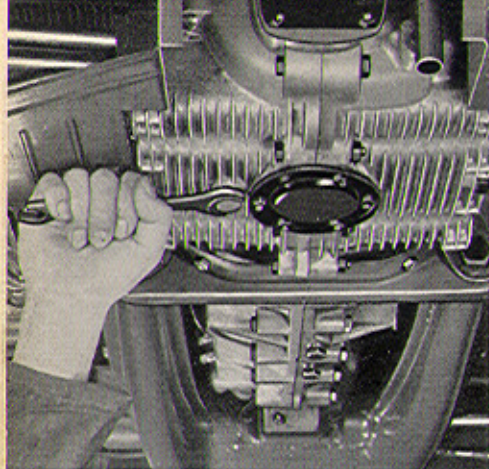

The oil is drained by removing the plug at the bottom of the crankcase. To insure complete draining, it is important that the operation be performed while the engine is warm.

The engine is refilled with
2½ liters of HD oil
(5.3 U.S. pints, 4.4 Imp. pints)

The constant use of HD oil renders a flushing of the engine unnecessary.

If, however, being compelled to use a regular engine oil not having the detergent-dispersant characteristics of HD oil, the oil should be changed at intervals of 2500 km (1500 miles). The engine should be allowed to idle while being flushed thoroughly with one liter (1 quart) of the same type of oil which you use afterwards for filling. This assures a better cleaning of the complete lubrication system.

Under no circumstances a so-called flushing oil, or even kerosene, should be used for flushing the engine. The residue of the flushing agent, which would remain in the crankcase and especially in the oil cooler, is liable to decrease the lubricating efficiency of the fresh oil.

Never allow a haphazard changing from HD oil to Regular oil and vice versa.

The Oil Strainer

retains foreign matter and should be taken out and cleaned as called for in the Lubrication Chart. When the strainer is inserted again, the lower side should lie beneath the bend of the oil intake pipe. The two gaskets should be renewed each time the strainer is removed.

- | | |
|------------------|-------------------------|
| 1 - Drain plug | 4 - Gasket |
| 2 - Gasket | 5 - Bottom plate |
| 3 - Oil strainer | 6 - Nut and lock washer |

Types of Lubricant and Recommended Usage

The advantages of using a **trade-mark HD oil** are quite evident.

Regular oils, i. e., non-additive oils, do not combat the formation of sludge and deposits and the wear-increasing bearing corrosion when the car is operated for short distances and during cold weather. HD oil is an oil having proved oxidation stability, bearing corrosion preventive properties and detergent-dispersant characteristics which tend to hold in suspension foreign contaminants which would normally deposit on engine parts. These foreign contaminants will drain out with the oil at the periodical oil changes. The detergent properties of HD oil will make the fresh oil darker already after a short time of operation. This is quite natural and there is no reason whatsoever to change the oil earlier than called for in the Lubrication Chart.

Upper lubricants and other agents, as colloidal graphite, etc., should never be added to HD oil.

Changing from One Type of Oil to Another

If possible, HD type oils should be used for all new VW engines right from the beginning. If, for any reason, the engine has operated with Regular engine oil for a longer period, the following should be heeded when changing to HD oil:

- If engine has performed less than 10 000 km
(6 000 miles)

no precautions are necessary when changing to HD oil.

- If engine has performed more than 10 000 km
(6 000 miles)

or if you are not quite sure what type of oil had been filled into the engine at earlier oil changes, precautions must be taken to thoroughly clean the engine. The VW Service personnel is fully conversant with this job and will be glad to advise you.

Some more Information on Engine oils

It is left to your discretion to select an oil from well-known and dependable brands, being of the proper viscosity to suit your seasonal and driving requirements. In cases of doubt, refer to your authorized VW Dealer who will be glad

to help you with your lubrication problems. It is recommended that you select "your" oil right at the beginning and stick to it at all future service oil changes. Viscosity of the lubricant is an indication of its resistance to flow at a given temperature. The SAE numbers classify lubricants in terms of viscosity, but with no reference to other characteristics or properties.

SAE 30 This oil is satisfactory in tropical climates where the temperature range will frequently rise above 30° C (86° F).

SAE 20/20 W This grade oil should be used within the wide temperature range between +30° C and -15° C (+86° F and +5° F). If temperatures temporarily exceed these limits, there is no need to change to another grade.

SAE 10 W Engine oil of this viscosity should be used for all types of vehicle operation where the temperature will fall below -15° C (+5° F). However, it should already be filled in when temperatures are expected to fall below -15° C (+5° F) before the next regular oil change is due. Oil of this viscosity may also be used in the warmer temperature range with safety.

SAE 5 W This extremely light oil is for use in arctic climates only.

Apart from the oils mentioned above there are so-called multi-grade oils. These oils cover the range of several SAE grades, for example, SAE 10 W, 20 and 30. Thus, an SAE 10 W/20 engine oil can be used both in severe cold and in summer.

In some countries API Classification is applied (API = American Petroleum Institute). According to this classification, the oils suitable for the VW engine are referred to as "For Service MS".

Ignition Distributor

The amount of grease at the breaker arm fiber block should be checked and, if necessary, replenished at the specified intervals.

Every 25 000 km (15 500 miles), apply 4 or 5 drops of oil to the felt in the cam bearing after the rotor is taken off.

Transmission and Differential

The transmission gears and the differential of your VOLKSWAGEN are combined in the transmission case and are lubricated jointly with gear oil. This kind of oil can be readily distinguished from motor oil by its heavier viscosity and darker

coloring. An early change of oil, while the gears are being broken in, will contribute to a smoother operation of the transmission. The used oil should be drained by simultaneously removing the two drain plugs, while the oil is still warm.

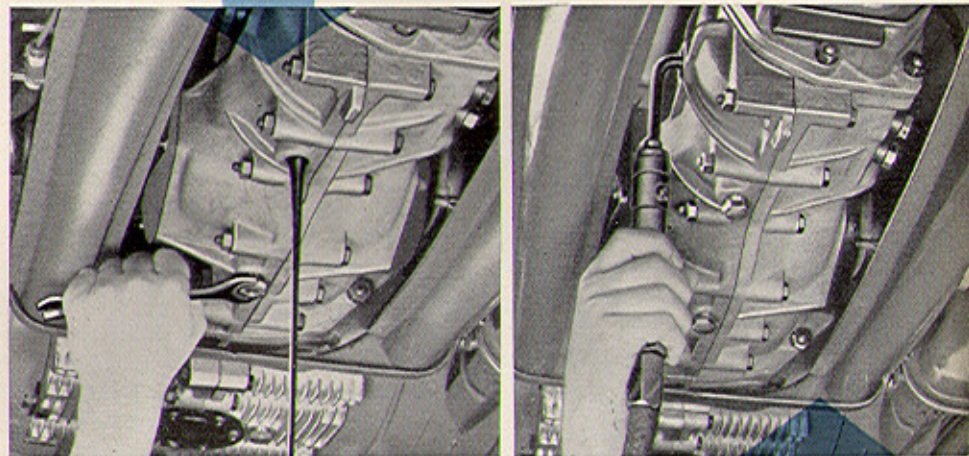

Then refill with **2 liters (4.2 U.S. pints, 3.5 Imp. pints) of gear oil.**

The oil level should be checked in accordance with the Lubrication Chart. Keep the lubricant level somewhat below the edge of the filler hole. In order to maintain the characteristics of the gear oil, it should not be mixed with any other oil, as the two will not blend.

Steering Gear

The steering assembly should be lubricated with gear oil exclusively, and under no circumstances with grease or hypoid oil. It is accessible through a hand-opening underneath the spare wheel. The level of the oil in the steering case should be kept somewhat below the filler plug hole.



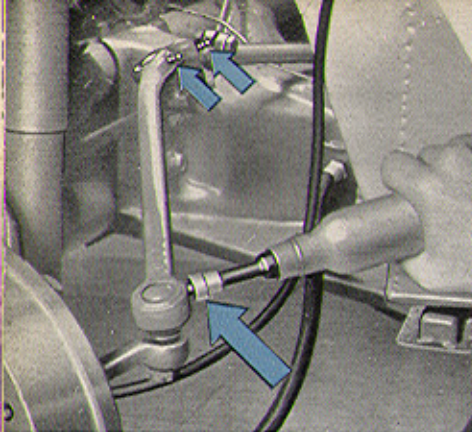

Chassis

A proper lubrication of the front axle bearing points is only insured by raising the front axle so that the weight is taken off the wheels.

Prior to lubrication, the grease nipples should be cleaned thoroughly with a clean piece of cloth, so as to avoid any dirt or foreign matter entering the nipples. The tip of the grease gun should be pressed onto the nipple, whereupon grease should be injected until the excess grease begins to emerge at the edges of the lubrication point.

If the car is driven mainly over rough roads, we recommend to lubricate torsion arm links and outer tie rod ends at more frequent intervals, say every 1250 km (800 miles).

Annually, at the beginning of the cold season, the cables and conduit tubes of clutch, accelerator and heating should be cleaned and greased.

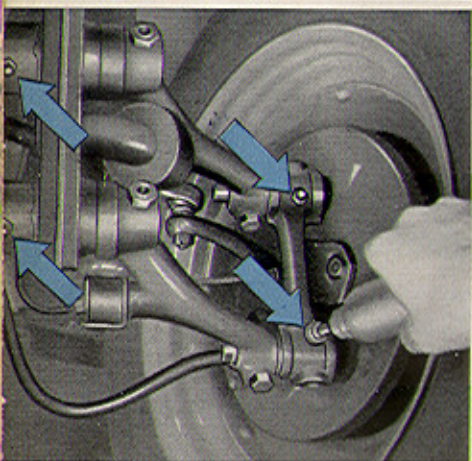

The Front Wheel Bearings

are sufficiently provided with grease already at the factory. The caps on the front wheel hubs must be free from grease.

At intervals of 2500 km. (1500 miles), the front wheel bearings are to be cleaned and repacked with 115 gr. (4 oz.) of grease for one wheel. First fill the ball bearings and use the remaining grease for the brake drum hub. Finally, the front wheel bearings must be adjusted. This operation should, if possible, be carried out at a VW Service Shop.

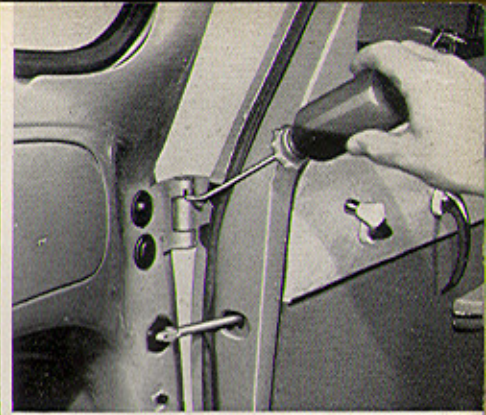
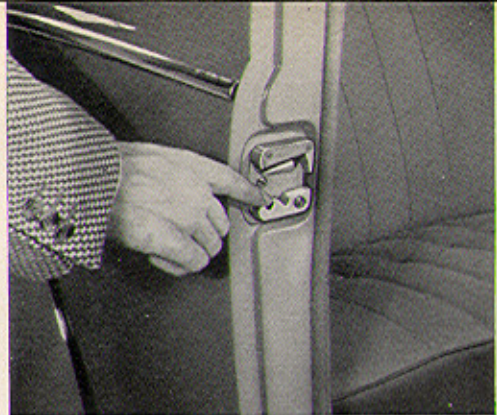

Doors

The door lock striker plates should be lightly greased. Apply a few drops oil to the door and hood hinges, after dust and soil have been removed.

The door hinges on the Convertible are provided with lubrication fittings. Prior to lubrication, the lubrication fittings should be cleaned thoroughly with a clean piece of cloth, so as to avoid any dirt or foreign matter entering the fittings. Wipe off any surplus grease afterwards.

Door cylinder locks should be treated with graphite only. Blow a small quantity of powdered graphite through the key hole. Dip the key into the graphite, insert key and move it back and forth several times.

Window Regulators

The window regulators are accessible after the regulator and inside door handles and the trim panel have been taken off. Press down the escutcheon plate, push out the pin and take off the handle. The trim panel is held by snap fasteners. Gears and joints of the window regulators (on the Convertible, the rear quarter window winder, too) should be greased, if found necessary after a longer period of service.

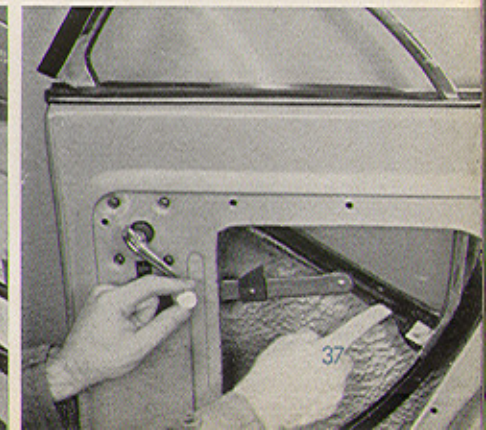
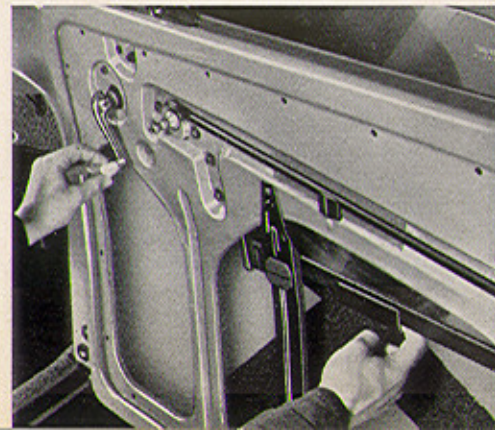



Front Seats

On the De Luxe and Convertible, the upper and lower sliding surfaces of the seat runners should be provided with grease. Only a small amount of grease is required to assure easy movement of the seats. Prior to lubrication, wipe off the runners with a rag. To remove, slide the seat fully toward the front. When installing the seat, hook the spring in position.

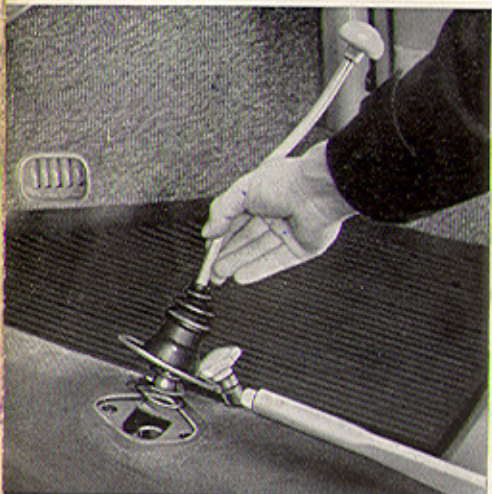

Gearshift Lever

The gearshift lever can only be lubricated when removed. To do this, remove the two screws that attach the lever dome to the frame tunnel and lift off lever, dome and spring as a unit.

The contact surfaces in lever dome, at stop plate and lever ball socket should be amply provided with universal grease. When installing stop plate, make sure that the turned-up edge is on the right-hand side.

After installation, make sure the gears engage properly. If necessary, correct position of gearshift lever.

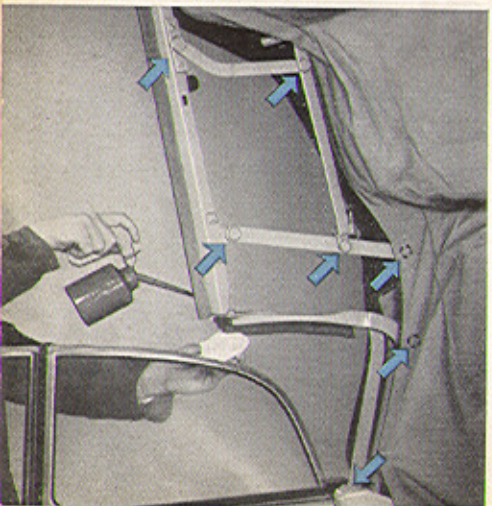

Convertible Top

The joints of the top linkages are lubricated by applying a few drops of oil after dust and dirt are removed. Care should be taken to avoid oil getting on to the top cover, as oil has a detrimental effect on the rubber in the topping.



Under-inflation or over-inflation are the most common causes for tire failures. High speed driving and cornering, skidding to a stop and striking curbs or objects on the road may wear tires more than many miles of careful operation.

Avoid overloading the car and protect the tires from intense sunlight, fuel, or oil.

Normal wear may be kept at a minimum by interchanging wheels and tires inclusive spare wheel at approximately 5000 km. (3000 miles) intervals. Rotate wheels as shown in the illustration.

A drop of oil applied to the wheel mounting bolts facilitates the next wheel change. To obtain a smooth high speed operation and a long tire life, it is important to have the wheels balanced statically and dynamically when tubes and tires have been repaired. When the tires are being mounted, the red mark on the sidewall should be aligned with the valve to insure better balancing of tube and tire.

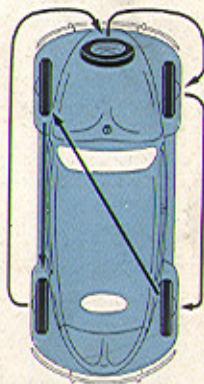

Changing Wheels

To change a wheel on the road and in the rain certainly is not a pleasant task. However, it will no longer be so difficult for you after you have read these few lines which will teach you how to go about it properly. Underneath the front hood, you will find the spare wheel, jack and tool kit.

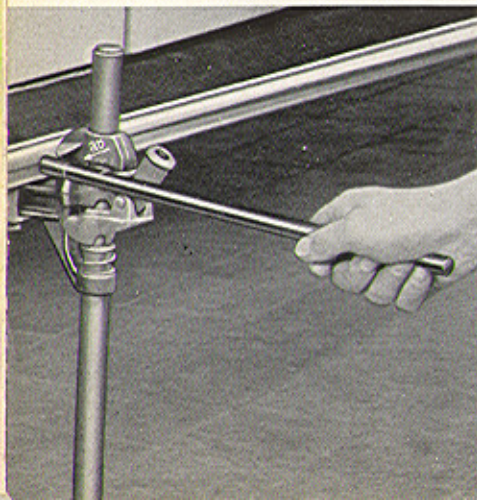

- 1 - Set the hand brake securely and block the wheel opposite to the one being removed to prevent the car shifting off the jack.
- 2 - Grip the square bar of the jack so that the thumb comes to rest on the nose of the upper locking piece. Exert pressure on the nose and slide down the square bar until it is stopped by the base plate.
- 3 - Insert the jack into the square tube below the body sill panel in front of the rear fender and push down the jack base plate until it makes contact with the ground.
- 4 - Remove hub cap.
- 5 - Loosen wheel bolts by means of the socket wrench before wheel is fully jacked up.
- 6 - Raise jack until tire clears ground.
- 7 - Remove wheel bolts and take off the wheel.
- 8 - When reinstalling the wheel, operate the jack until the five holes in the wheel are nearly lined up with the holes in the brake drum.
- 9 - First, insert one wheel bolt only. Tighten it to such a degree as to allow the wheel to be swung around this point by hand until the remaining holes in the wheel and brake drum coincide.
- 10 - Insert the remaining bolts until the countersunk heads rest centrally in the corresponding recesses of the disc-wheel.
- 11 - Tighten all bolts diametrically opposite in turn.
- 12 - Place one end of the jack operating rod between the two noses at the point marked "ab" and apply a light pressure on the opposite end of the rod to lower the car to the ground. Keep on exerting a pressure on the operating rod to allow the base plate to be pushed up, and remove the jack.
- 13 - Make sure that all bolts are tight.
- 14 - Install hub cap and make sure that it is tightly seated.



CARE OF THE CAR

Clean and Neat Appearance

To keep the VOLKSWAGEN looking smart and new should be a matter of pride to the driver or owner of the car. We made it the object of our efforts to offer a lasting paint finish of sparkling lustre. A chemical treatment, called Bonderizing, protects the body against rust and corrosion and anchors the paint securely to the metal. The finish is of high-quality synthetic resin and carefully blended to obtain the most beautiful shades.

You will realize the importance of the paint finish if you consider that it is exposed to the elements; it has to resist dazzling sunshine, rain, dust and dirt. That is why a periodic care of the body is necessary to retard any disintegrating process.

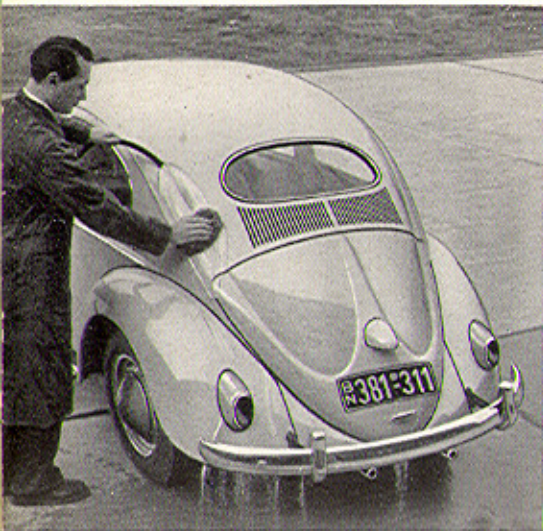

Washing Your Car

Wash your new car frequently during the first weeks. This practice will be of great advantage to the finish. For washing your car you require a soft sponge for the body, a soft brush for the wheels, a sturdy, long-handled brush for the chassis, and plenty of clear water! For drying the car you need a chamois.

The chassis and lower part of the body should first be flushed with water, to soak off the dirt, and afterward a brush should be used.

Apply an even spray of water on the exterior finish of body and wheels until dirt is soaked off. Do not allow a hard shot of water to hit the varnished surface. Using plenty of clear water, dirt should be removed with a sponge. Care should be taken to clean the sponge at short intervals so as to avoid scratches on polished parts. There are some approved shampoos which greatly facilitate this job. Avoid the use of any product which has not been recommended by your service station. It is of utmost importance to wash the body thoroughly with water after the shampoo has been applied to insure that no traces of it remain on the body.

After washing, rub down with a clean chamois to prevent water spots. Some cleaners even render the rubbing down unnecessary and it is sufficient to remove traces of water.

Preservation

means to restore certain greasy substances which have been removed from the finish after a longer time by weather influences. As the greasy substances are vitally important to the elasticity of the finish, it is necessary to apply a protective water-repellent coat of wax on the body. The intensive cleaning effect of the shampoo removes this protective coating so that it should be renewed accordingly. A preservative specially produced for the finish of your VOLKSWAGEN can be obtained under the designation "L 90" from your service station. The body

should be subjected to a wax application after the first eight or ten weeks and then regularly at intervals of from six to eight weeks — in any case after each shampoo washing, as already mentioned. Applying the preservative is quite easy; spray it on the body or use a soft cloth, then rub it down when dry, using polishing cotton or a soft polishing cloth, until prismatic colors can no longer be seen when standing at an angle to the polished area.

Of course, the car must be washed and dried carefully prior to applying the preservative.



Polishing

You should polish your car only if its appearance has been strongly affected by road dust, sunlight and rain as a consequence of an insufficient care, and if the application of the preservative no longer restores the original lustre. Avoid the use of abrasives or chemically harmful products, even if their first application seems to give satisfactory results. A special polish for treating our synthetic-resin finish is also obtainable from our service stations under the designation "L 170".

Prior to applying the polish, the car must be washed and dried carefully. Dust or soil should never be wiped off in a dry state. The polish should be applied with a soft and clean cloth or polishing cotton — use a straight horizontal or vertical motion rather than a circular motion. After some time of rubbing you will feel a slight resistance, which indicates that the ingredients of the polish have settled in the finish and that the solvent has evaporated. Now take clean polishing cotton and rub the body down until the high lustre is restored. Do not apply the polish on too large an area of the body at a time. A subsequent application of the preservative gives you care-free pride in your car for a long time.

Never wash or polish the car in sunlight or when the metal is warm.

How to Remove Spots

By a mere washing you cannot always remove splashes of tar, oil traces, "baked on" insects, etc. As a matter of principle, such foreign matter should be removed as soon as possible, for if you neglect this rule, permanent damage may result to the finish.

Tar Spots

An unpleasant sight, to be noticed particularly on light-colored cars, are tiny tar spots which show up on the fenders on hot days when driving on newly tarred roads. Tar splashes have a tendency to corrode the finish within a short time and should be removed immediately when discovered. On the way, you usually have nothing at your disposal but fuel, which may be applied with a soft cloth. Kerosene or turpentine oil may also be used. After this, the treated spots should be washed with a mild, lukewarm soap-solution, and rinsed, in order to remove traces of the cleansing agent. It is, however, better to use our preservative already mentioned, which renders the treatment with soap-solution unnecessary.

Insects

are caught especially during the night, in hot weather, by fenders, headlights, and front hood. Once baked on they can hardly be removed with water and sponge, but should be treated with lukewarm soap-solution.

Blooming Trees

but more especially lime-trees, in many instances drop tiny quantities of liquids. Cars that have been parked underneath such trees become "freckled" all over. These stains, too, can be readily taken off with soap-solution.

A treatment of the cleaned spots with the preservative is strongly recommended.

Cleaning Sun Roof

The plastic cover of the sun roof does not call for special care. It can be kept in good condition by cleaning it at long intervals with mild soap suds or shampoo and rinsing thoroughly with clear water. Never attempt to remove spots with kerosene, mineral spirits, alcohol, or acetone, as these will attack the plastic cover.

Care of the Convertible Top

The appearance and life of the top greatly depends on a proper care and maintenance.

The top must always be perfectly dry before lowering it. When having driven the car on dusty roads, slightly beat out the top and brush the fabric in line with

the lay of the thread by means of a soft brush, as the sharp foreign particles harm the top fabric when not removed within a short time.

Damage due to friction may occur when the lowered top is not tightly held in position by the catches which engage in the slots cut in the side rails. In such cases, the catches should be screwed further into their retainers. To do this, the lock nuts are to be loosened before and tightened after the adjustment.

Spots can be removed from the material with an "art" gum eraser and brushed off with a whisk broom. Never use fuel or another volatile cleaner, as they destroy the rubber ply in the top cover, leading to leaks and shortening the life of the top.

The top should be washed only when it is exceptionally dirty. Only use clear water which is free from chemical products or other additives. Prior to washing, beat out the top and then brush it off. Use luke-warm water and a mild soap, only such soap as castile or olive oil base soaps should be used. Moisten the top with clear water and apply the thick suds. Scrub the top with a soft brush. After scrubbing, flush off the suds with clear water. If necessary, repeat the scrubbing with suds. There should be no traces of the suds when the top has been flushed. Be sure the top is thoroughly dry before lowering.

After washing the top, clean the finish of the car by flushing with clear water and rubbing dry with a clean, soft cloth.

Chromium-Plated Parts

should be lightly coated with chromium wax. The use of grease or vaseline is not recommended as these will bind dust and dirt.

Care of the Cloth Upholstery

If no vacuum cleaner is available, the upholstery should be cleaned thoroughly with a brush or whisk broom. Grease and oil stains on the upholstery or interior trim cloth are removed with cleaning fluid. Do not pour the cleaning fluid directly on the spot to avoid forming a ring. Moisten a clean, not colored, cloth with the fluid and rub with a circular motion, starting outside the spot and working inwards to the center.

Other stains can generally be removed with lukewarm soap-suds.

Care of Imitation Leather Upholstery

It is recommended to clean the artificial leather upholstery with a soft cloth or a soft brush. Special care should be taken to remove dust and dirt also from the upholstery seams. A better cleaning effect is obtained by the use of a soft whisk broom and a suds of lukewarm water (rain water, boiled or soft water) and any mild soap (castile or olive oil base soaps). Use the water sparingly, the upholstery otherwise requires a long time to dry, if water trickles through the seam stitches. After completing the cleaning operation, use a clean, soft cloth to polish the surface of the leather. Carefully treat the upholstery seams. Never use furniture polishes, oils, varnishes or cleaners on imitation leather upholsteries. They will injure the finish.

Care of Leather Upholstery

The leather upholstery should be serviced in accordance with the instructions given for the imitation leather upholstery. After the upholstery has been wiped dry, an accredited cleaner may be used to clean, preserve and brighten the appearance.

Cleaning Glass

The windows can be cleaned by washing with water and wiping dry with a clean, soft linen cloth or chamois. In order to facilitate this task on the windshield, the arms of the windshield wipers may be bent forward. To clean unusually dirty glasses, use alcohol or household ammonia and lukewarm water.

Door and Window Weather Strips

To assure a perfect door and window seal on the Convertible, it is important to keep the rubber parts undamaged and supple. To retain the original flexibility and to reduce friction, it is recommended to apply a light coating of talc powder to all rubber parts after each car wash. Frictional noises between the side window frames and the rubber strips on the Convertible can be easily eliminated by using a mixture of glycerin and talc powder.

Airing the Interior

If the car is left stationary for a longer period in your garage, attention should be paid to the airing conditions. Permit air to circulate freely through the body by opening the doors and lowering the windows to prevent a forming of mould and damp-stains.



MAINTENANCE

The VOLKSWAGEN SERVICE ORGANISATION has made available for you an extensive network of Authorised VW Service Stations, staffed with well trained and experienced men, and equipped with all the required special tools and appliances to service your car. In event the need for service arises when touring, or far away from home, look for the well known VW Service Sign. The workshop displaying this sign is your assurance of the same expert, prompt, and courteous service you are accustomed to receive at home.

In the case you can't get to an Authorised VW Service Station in time, we are giving you some information which, if needed, will help you to carry out normal maintenance work. However, repair jobs which are beyond your capacity can only be performed by your next VW Service Station. There your car will be given expert treatment by those familiar with its construction.

This will save you time, inconvenience, and money.

Servicing Air Cleaner

The air cleaner filters particles of dirt and grit from the air. Regular servicing is especially important in dusty areas. A dirty air cleaner is responsible for frictional wear, decreasing operating efficiency, and increasing fuel consumption.

The oil bath air cleaner should be serviced every 5000 km. (3000 miles). Detach cleaner from carburetor, unfasten the strap and disassemble the cleaner. Remove dirty oil from reservoir and refill with fresh engine oil SAE 20 up to the mark (approx. 0.25 liter/0.5 pint). The filter element should be rinsed in fuel, kerosene, or any other degreasing solution. The oil level in the fluid reservoir should be checked every 2500 km. (1500 miles). When topping up, take care that the oil level is not above the mark.

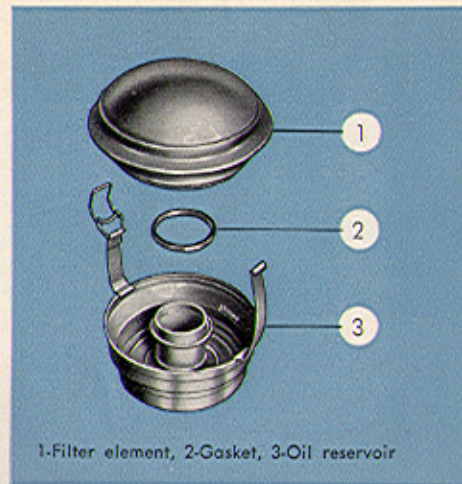

If the car is mainly operating under desert or other extreme conditions of dust-laden atmosphere, it is up to you to prevent premature wear by more frequently servicing the air cleaner than prescribed above.

The oil bath air cleaner should always be cleaned, if there is no thin oil above the sludge at the bottom of the fluid reservoir.

Adjusting the Fan Belt

To adjust the fan belt, remove nut and outer half of generator shaft pulley. When loosening or tightening nut, insert a screwdriver in the slot cut into the inner half of the pulley, and support it against upper generator housing bolt. The adjustment of the fan belt tension is effected by means of spacer washers situated between the two pulley halves. Belt slackness is taken up by removing one or more washers. If the belt is in too much tension, one or more washers should be added.

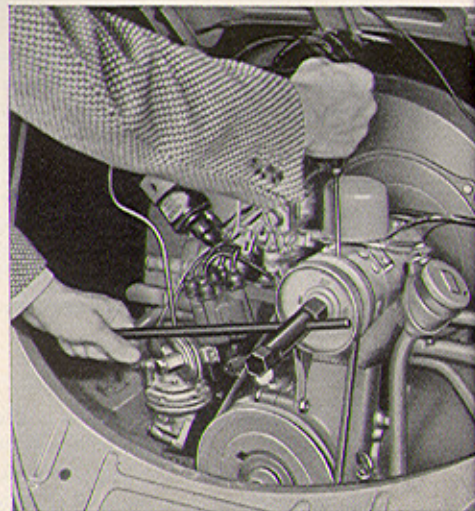

The fan belt should not be too loose, nor should it be too tight. Newly installed belts will stretch to some extent and should, therefore, be checked and adjusted after 50—100 kilometers (30—60 miles) of running.

Cleaning the Carburetor

To clean the carburetor, remove the bowl cover.

Bowl cover removal

- 1 - Remove the air cleaner.
- 2 - Disconnect the fuel line at the carburetor.
- 3 - Remove the screws that attach the cover to the carburetor bowl.
- 4 - Lift the carburetor bowl cover. For the complete removal of the carburetor bowl cover, the choke control cable must be disconnected.

To reassemble the unit, proceed in reverse order. Install a new gasket and be sure of its proper position between bowl and bowl cover.

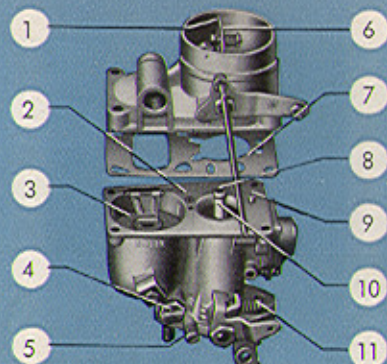
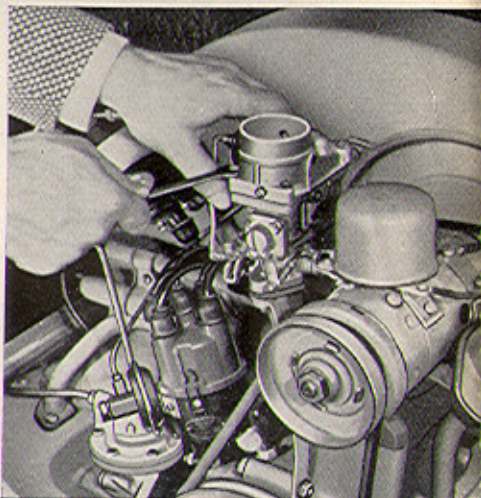
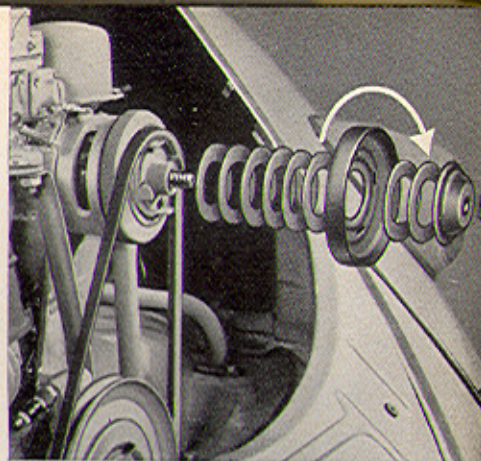

1 - Choke,
2 - Pilot jet air bleed,
3 - Float,
4 - Main jet,

5 - Volume control screw,
6 - Poppet valve,
7 - Gasket,
8 - Air correction jet,

9 - Pump pipe fitting,
10 - Emulsion tube,
11 - Idle adjusting screw,
12 - Accelerator pump,

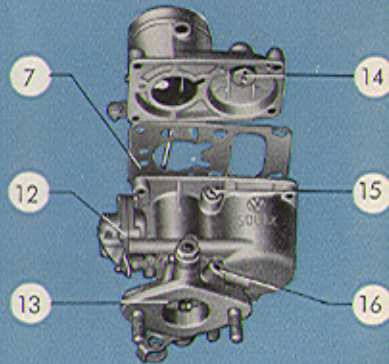

13 - Throttle,
14 - Float needle valve,
15 - Pilot jet,
16 - Vacuum pipe connection

Cleaning

- 1 - Remove float and lever assembly.
- 2 - Remove the main jet plug and clean main jet and float chamber.
- 3 - Clean pilot jet air bleed.
- 4 - Clean pilot jet.
- 5 - Clean air correction jet and emulsion tube.
- 6 - Clean the float needle valve.
- 7 - Clean accelerator pump discharge passage.
- 8 - Clean float-bowl-to-accelerator-pump passage.

Adjustment

The carburetor is tested at the factory and properly adjusted to the engine. Do not alter this adjustment by exchanging the jets, or by changing the venturi for other than the prescribed sizes. This would be detrimental under normal operating conditions and may result in hard starting, excessive fuel consumption or unsatisfactory engine performance. Only an idling adjustment will be necessary from time to time. **Before attempting to adjust the carburetor, make sure the engine is at normal operating temperature.**

- 1 - Turn the volume control screw in until it seats lightly, then back it off approximately $\frac{3}{4}$ turn.
- 2 - Turn the idling adjusting screw in or out until the approximate idling speed is attained.
- 3 - Gradually turn in the volume control screw until the position is found where the engine just tends to stall, then back it off by $\frac{1}{4}$ turn.
- 4 - Finally re-adjust the idling adjusting screw until the engine runs at normal idling speed.

The adjustment is perfect if the engine does not stall after the throttle either is suddenly opened or suddenly shut with the clutch pedal depressed. Poor idling may also be the result of damaged gaskets, intake manifold flanges not sufficiently

tightened, faulty ignition or leaky valves. Skilled hands and experience are required to check and adjust the carburetor and the accelerator pump. For this reason you should leave this job to an Authorized VW Service Station.

Valve Adjustment

Proper adjustment of the valve clearance is important to prevent burning of valves and poor engine performance.

The following procedure should be carried out only in such emergencies when it is impossible for you to reach a VW Service Station.

Valve clearance should be 0.10 mm. (.004") with the engine cold. The valve clearance increases when the engine warms up. For this reason,

only adjust valve clearance when the engine is cold (at room temperature).

The arrangement of the cylinders can be seen by the numbers 1 to 4 indented in the cover plates.

Valve adjustment may be made in the following sequence: 1st - 2nd - 3rd — 4th cylinder.

Adjust the valves when the piston of the corresponding cylinder is in top dead center position of the compression stroke. Starting with the 1st cylinder, crank the engine over slowly to the left by the fan pulley, until both valves are in fully closed position and the timing mark on the pulley is in line with the vertical jointing faces of the crankcase.

If the clearance requires adjustment, loosen the lock nut of the adjusting screw and turn the adjusting screw as required to obtain the proper clearance. Tighten the lock nut and recheck the clearance. Readjust if necessary. Check and adjust the other valves to the proper clearance in this manner by turning the crankshaft anti-clockwise another 180° for each cylinder.

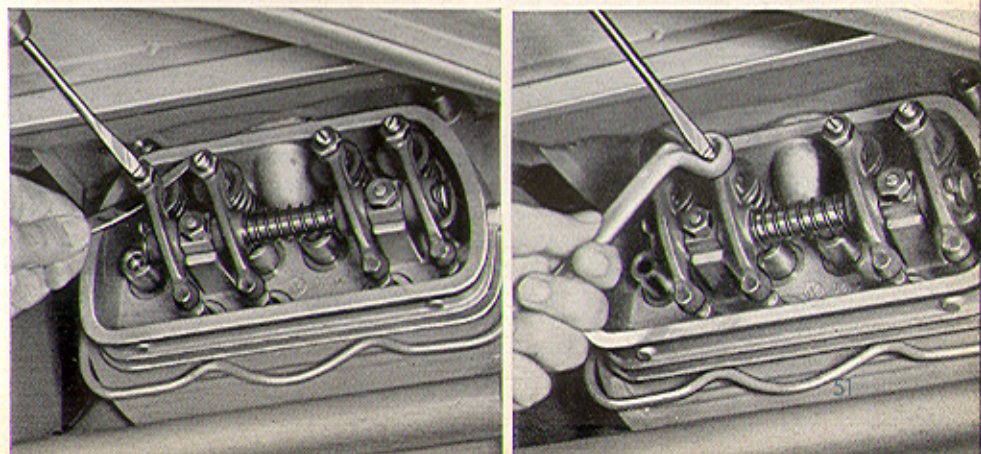
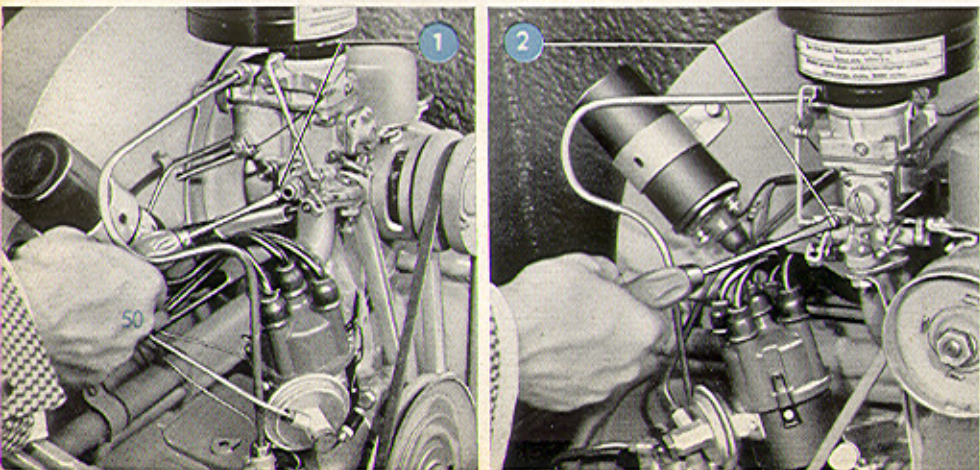

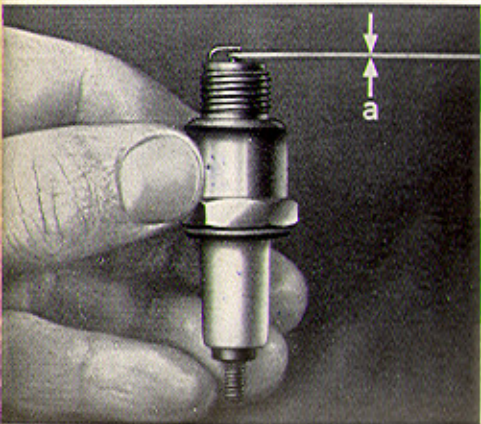
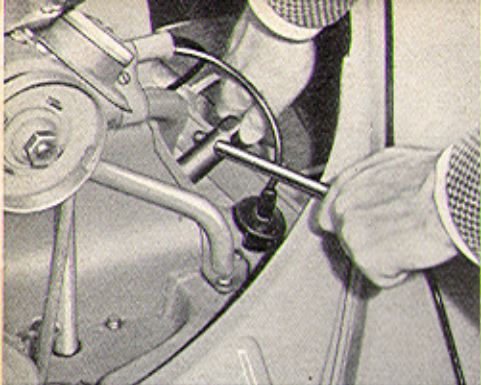

a — 0.6—0.7 mm (.024—.028")

Check the electrode gap (0.6—0.7 mm. = .024—.028") and reset if necessary by bending the outer electrode. Look for a proper gasket before installing the plug. Generally speaking, you may count on a service life of the spark plugs up to 15,000 km. (9300 miles).

Ignition and Timing

Sufficient attention is not attached to the importance of correct ignition timing. The engine operating will be seriously affected if the ignition breaker points are not properly timed and correctly spaced. In many cases poor performance, high fuel consumption and even severe damage to the engine are the result of unskilled setting of the ignition. Normally, the adjustment should be carried out by an Authorized VW Service Station when the car is brought in for regular inspection. A few practical hints are given herewith, however, because in our experience damage is apt to result if the technical facts and data are not known.

Checking the Spark Plugs

The spark plugs must be thoroughly maintained for easy starting and economical operation. Remove the plugs and inspect the exterior.

Electrodes and insulator

- | | |
|-------------|--|
| medium grey | — good adjustment of carburetor and correct performance of spark plug, |
| black | — mixture too rich, |
| lightgrey | — mixture too lean, |
| oiled up | — failure of spark plug or worn-out cylinder. |

In the case of fuels containing lead-tetra-ethyl (anti-knock fuel), the insulator will show a grey color, provided the engine is correctly adjusted.

Clean the spark plugs with a brush and a chip of wood and blow them out. Inspect the spark plug for cracked insulator and burned or pitted electrodes. The insulator should be clean and dry on the outside as well to avoid short-circuits.

Adjusting Contact Points

Remove distributor cap and rotor. The breaker contact points are adjusted by cranking the engine until the fiber block on the contact arm rests on the highest point of the cam lobe. Then loosen the stationary point locking screw and turn the eccentric adjusting screw until the correct gap is obtained. Use a feeler gauge of the proper thickness (0.4 mm. = .016"). Tighten lock screw and recheck the gap. If the points are burned, rough or pitted, replace them. The distributor cap should be clean and dry to avoid short circuits.

After the contact points have been adjusted, it is absolutely necessary to check the ignition timing.

Ignition Timing

Crank the engine clockwise until the mark of the crankshaft pulley lines up with the vertical crankcase jointing faces and the distributor rotor arm is in the position for firing on the No. 1 cylinder (see mark on rim of distributor base). Loosen the lock screw below the distributor base and rotate the distributor body clockwise until the contact points are closed. Now switch on the ignition and rotate the distributor slowly counter-clockwise until the contact points just mark to open. This may be seen and heard, for a spark will jump from one point to the other.

To obtain a more accurate adjustment for maximum results, it is advisable to use a test lamp (6 volts) or an ignition timing light. The test lamp should be connected to the distributor primary lead terminal and to the ground. The lamp will light up as long as the contact points are kept open by one of the four cam lobes of the distributor shaft. After the adjustment is completed, tighten the lock screw, replace the rotor and clamp the cap on the distributor. Check for tightness the union nuts of the pipe connecting carburetor and ignition vacuum advance.

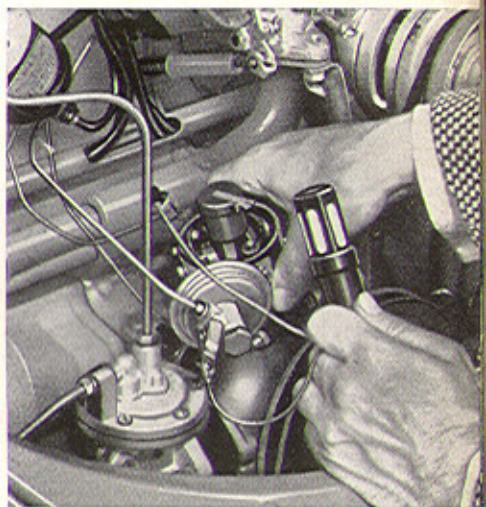
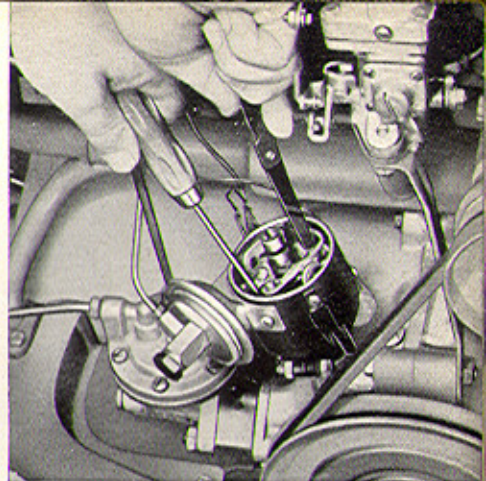

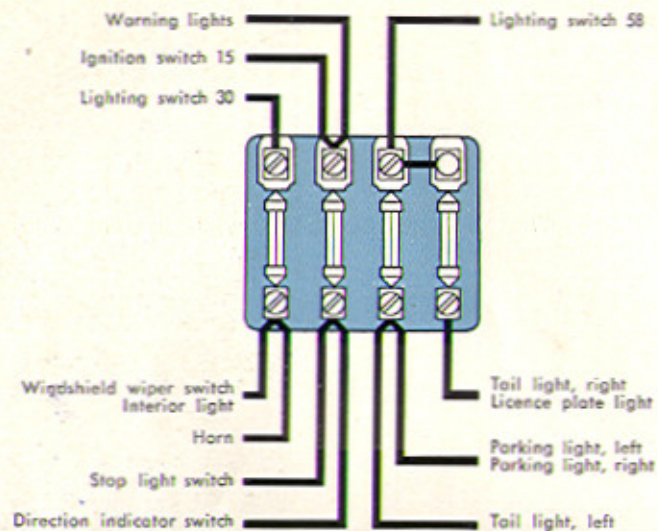

Fuse box on the back of the instrument panel

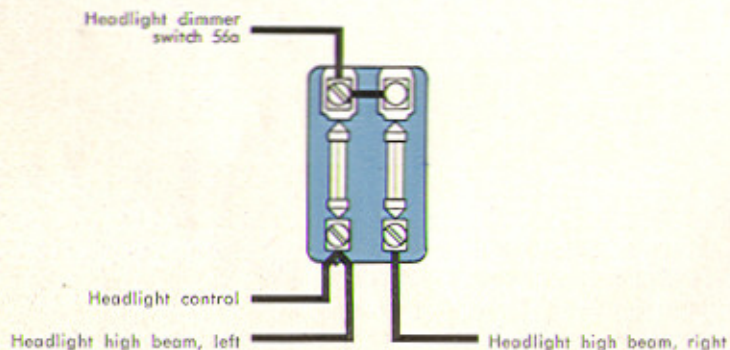

Fuse box adjacent to the fuel tank

Exchanging Fuses

Fuse boxes are located as follows:

- a - underneath the front hood, on the left side next to the fuel tank,
- b - underneath the front hood on the back of the instrument panel.

When a fuse has blown out, it is not sufficient to merely replace it by a new one. Inspect the electrical system for evidence of short-circuits or other faults that may have caused the fuse to blow out.



Bulb Replacement

Loosen the slotted screw at the bottom of the headlight rim. Pull out the lens and reflector unit, unhook the supporting spring, and remove the lamp holder. When replacing the bulb, make sure the new bulb is clean and that it is not loose in the socket. When a broken lens is being replaced, the reflector should not be touched or wiped off.



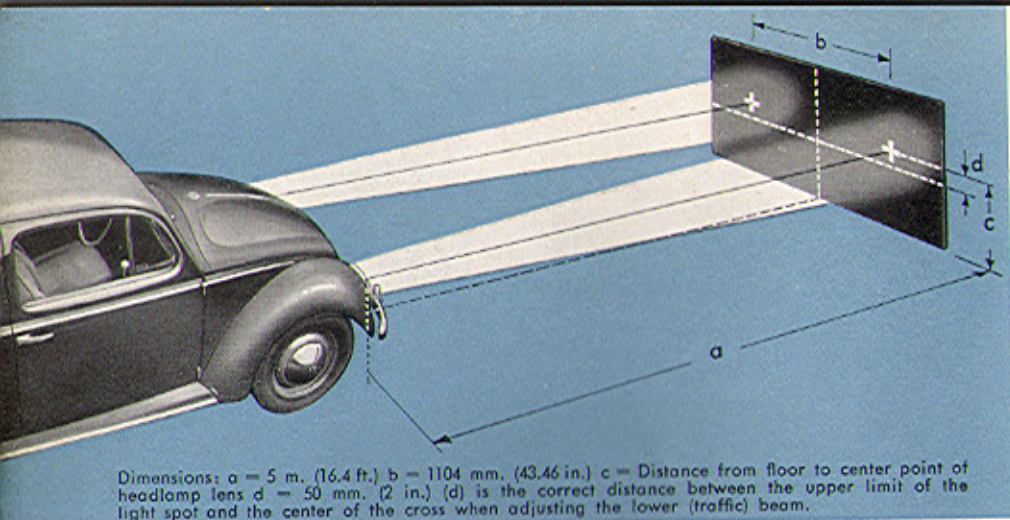

Dimensions: a = 5 m. (16.4 ft.) b = 1104 mm. (43.46 in.) c = Distance from floor to center point of headlamp lens d = 50 mm. (2 in.) (d) is the correct distance between the upper limit of the light spot and the center of the cross when adjusting the lower (traffic) beam.

Aiming the Headlights

If no headlight aiming device is available, proceed as follows:

- 1 - Place the unladen car on a level position with a dark-colored vertical screen 5 m. (16.4 feet) ahead.
- 2 - Next draw two cross lines on the screen according to the scetch.
- 3 - The longitudinal center line (car axis) must hit the center of the screen exactly between the two cross marks.
- 4 - Switch on the upper (country) beams and check the beams at the cross marks.
- 5 - Independent adjustment of both horizontal and vertical aim is provided with the adjustment screws accessible from the front of the headlight rim.

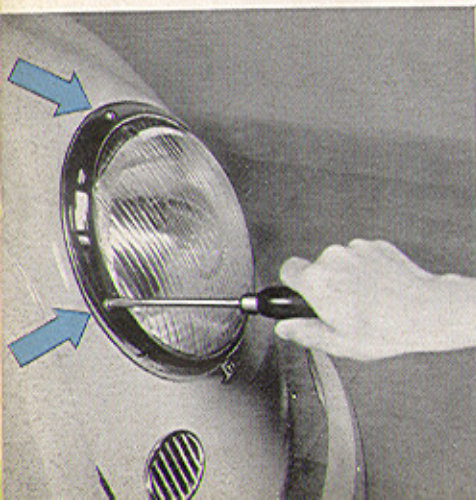

"Bosch" Headlights

Vertical Adjustment

Turn upper screw
to right — Beam swings down
to left — Beam swings up

Horizontal Adjustment

Turn right screw
to right — Beam swings to left
to left — Beam swings to right

"Hella" Headlights

Vertical Adjustment

Turn left screw
to right — Beam swings up
to left — Beam swings down

Horizontal Adjustment

Turn right screw

- to right — Beam swings to right
- to left — Beam swings to left

("Right" and "Left" is as seen in driving direction.)

Then switch on the lower beam and check the distance between the upper limit of the light spot and the center of the cross (2").

Licence Light Bulb Replacement

The combined stop and licence plate lights are accessible after the rear hood has been lifted up. To replace the bulbs, loosen the two wing nuts attaching the lamp holder and pull out the holder.



Stop and Tail Light Bulb Replacement

To replace the bulbs of the two combined stop and tail lights on the fenders, remove the slotted screw, lift the bezel away from the body, and pull out the bulb holder. When inserting the bulb holder, make sure the tongue at the bulb holder disc engages properly in the slot provided in the reflector.

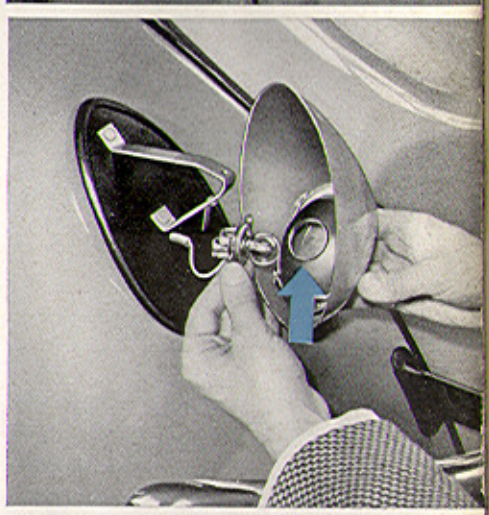

Warning and Instrument Light Bulb Replacement

The lamps for oil pressure, charging, direction indicator and headlight main beam control as well as the speedometer lamps are accessible after the front hood has been opened. Next remove the cover in front of the instrument panel. The bulb sockets can easily be pulled out from their holders.

1 and 3 — Speedometer lighting bulbs
Warning lamps: 2 — Headlights, 4 — Oil pressure, 5 — Direction indicators, 6 — Generator

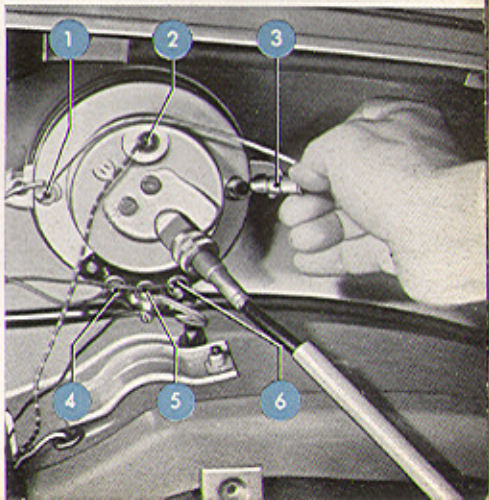

Battery Maintenance

The battery is located underneath the rear seats, where it is easily accessible for servicing. Ready starting of the engine depends upon perfect condition of the battery. Inspect the battery regularly as prescribed in the maintenance chart and even more frequently under conditions of extreme heat.

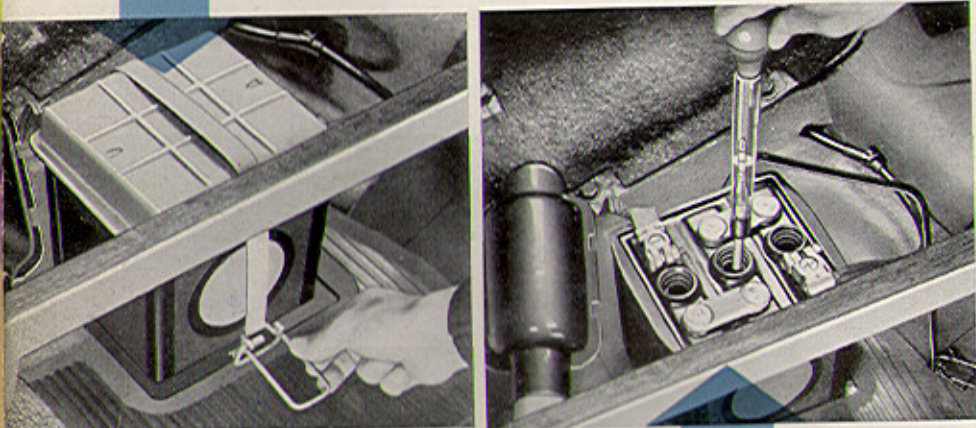

Hydrometer Test

The state of charge of the battery may be checked by means of a battery hydrometer. The specific gravity of the battery liquid will increase with the charging of the battery. Tested with the hydrometer, the gravity can be read from the scale of a float.

Battery fully charged	1.285 = 32° B ₆
Battery semi-charged	1.230 = 27° B ₆
Battery fully discharged	1.142 = 18° B ₆

Voltage Test

In addition, a voltmeter test should be made to insure that the battery is in good operating condition and able to provide the necessary current. The voltage of each cell should not fall below 1.6 volts while taking the reading (10—15 seconds). Otherwise the cell is discharged or defective. Under no-load conditions each charged cell should read 2.0 volts.

Levelling Battery Liquid

Add distilled water to each cell to bring the level to approximately 15 mm. (.59") above the plates. Losses by evaporation may only be replenished by adding distilled water. Never add acid, unless it is known that acid has been spilled from the battery. Check specific gravity afterwards and compensate if necessary. Check condition of the battery posts and the cable terminals. They must be clean and tight to prevent excessive electrical resistance. Use a stiff brush to remove

corrosion from both posts and terminals. Coat the clean posts and terminals with light grease or vaseline to prevent corrosion. Make sure that the battery is properly grounded.

Brake Adjustment

Brake adjustment should be performed by an Authorised VW Service Station. However, if an emergency arises where the brakes must be adjusted before you can reach the next repair shop, the following procedure for bleeding and adjusting can be used.

Hydraulic Brake

(De Luxe and Convertible)

The fluid reservoir is located under the front hood behind the spare wheel. To fill up, use only **Genuine VW Brake Fluid** or **Lockhead Brake Fluid**. The fluid reservoir should be kept at least $\frac{3}{4}$ full at all times.

Bleeding Hydraulic System

The hydraulic brake system must be bled whenever a fluid line has been disconnected or air has got into the system. The presence of air will cause "spongy" brake pedal operation.

- 1 - Remove rubber cap of the bleeder valve of one wheel cylinder and attach one end of the brake bleeder hose to the valve. The longest brake line must be bled first.
- 2 - Place the opposite end of the bleeder hose in a glass container partly filled with brake fluid so that the end of the hose is submerged.
- 3 - Turn the bleeder valve to the open position (1—2 turns).
- 4 - Pump the brake pedal several times, forcing fluid through the lines. When bubbles cease to appear in the container, close the bleeder valve and remove the hose. Replace rubber cap. Make sure that enough brake fluid

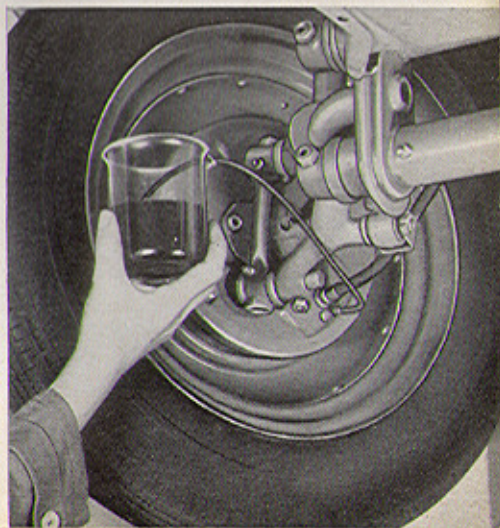

remains in the fluid reservoir, since otherwise air will be sucked in. The brake pedal should be kept in the fully depressed condition until the bleeder valve is closed.

- 5 - Repeat the above operations on the other wheels.
- 6 - When the bleeding is completed, refill the master cylinder reservoir with brake fluid.

Adjusting Hydraulic Brake

Brakes require periodic adjustment to assure their proper operation. Too much free travel of the brake pedal is an indication that the clearance between brake shoes and brake drums has become too great and that the brakes need adjustment. This adjustment will usually compensate for such wear that will take place until relining of the shoes is required.

- 1 - Jack up all wheels clear off the floor. Turn forward the wheel to be adjusted, until the hole in the brake drum is in line with one of the adjusting nuts.
- 2 - Insert a screwdriver through the hole and turn the adjusting nut in the direction indicated by the arrow, using screwdriver as a lever, until a slight drag is noted when wheel is turned by hand.

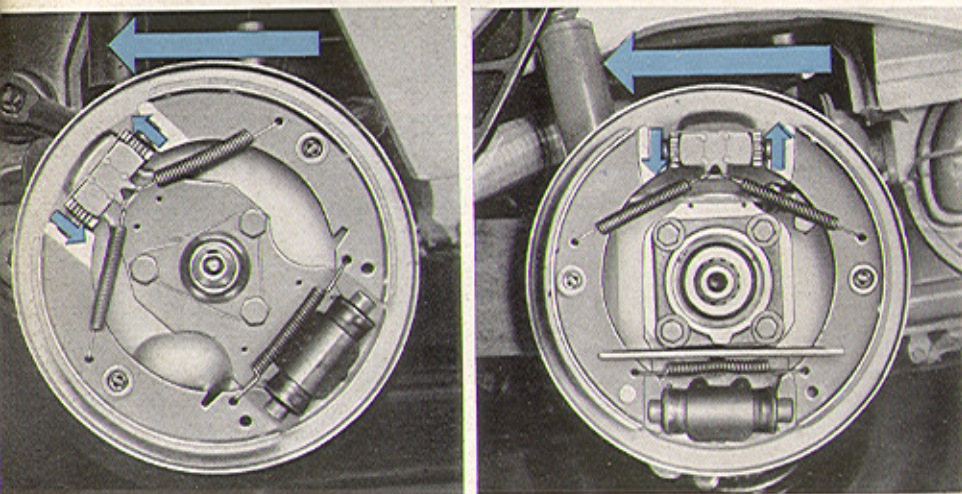

- 3 - Repeat procedure on the other adjusting nut. Note the opposite turning direction of the two nuts.
- 4 - Back off the adjusting nuts by 3 to 4 teeth.
- 5 - Repeat the above operations on the other wheels.

When adjusting the rear brakes, the hand brake must be released.

Adjusting Hand Brake

- 1 - Jack up both rear wheels.
- 2 - Unfasten hand brake lever rubber boot and slide it forward.
- 3 - Tighten adjusting nuts on the front ends of the brake cables to a degree which will still allow the rear wheels to turn freely when the hand brake is released.
- 4 - Pull up hand brake lever by two notches and make sure both rear wheels have the same braking effect. At the fourth notch it should be impossible to turn the wheels by hand.



Adjusting Mechanical Brake (Standard Model)

- 1 - Jack up all wheels clear off the floor and release the hand brake lever. Loosen the counternuts and brake cable adjusting nuts at the brake backing plate and turn both clockwise, that is, towards the brake backing plate.
- 2 - Tighten brake shoe adjusting nut until the brake drum no longer can be turned by hand.
- 3 - Turn back brake cable adjusting nut until there is very little clearance between brake cable and brake backing plate. Tighten counternut.

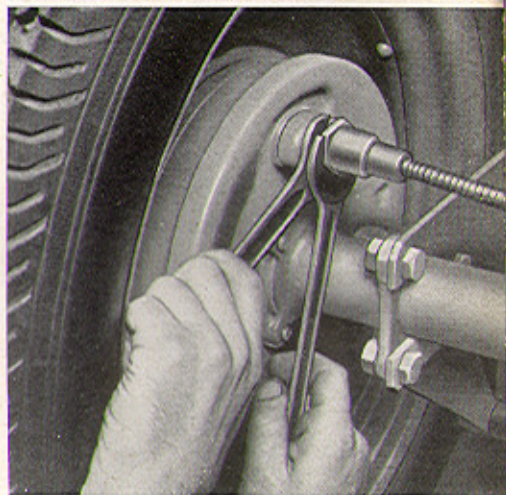

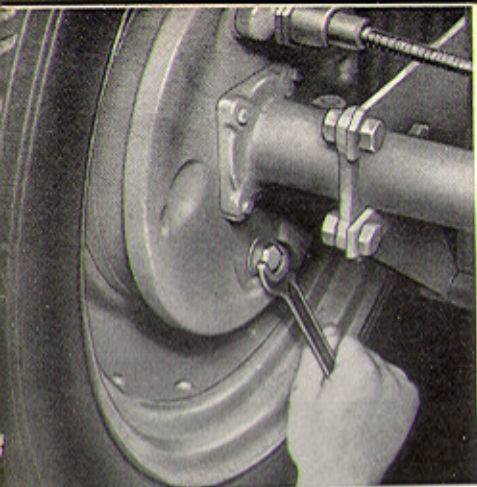

- 4 - Again loosen the brake shoe adjusting nut, until the brake drum can still be turned freely. A light tap against the nut will place the brake shoes and the adjusting cone in the right position.
- 5 - Repeat the above operations on the other wheels.
- 6 - Pull up the hand brake by two notches and check equal braking effect on all four wheels. Pull up hand brake for another notch and repeat check-up procedure. At the fourth notch it should be impossible to turn the wheels by hand.

7 - In case there is a difference in the braking effect between the four wheels, release the hand brake and loosen the brake-shoe adjusting nut on the wheel with the highest braking resistance. The brake cable adjusting nut, however, should not be readjusted. It likewise would be wrong to tighten the adjusting nut on a wheel which shows a lesser braking resistance.

8 - Lower the car and make a road test to assure proper brake operation.

Steering Gear

The need for adjustment will be evidenced by the development of excess free play in the steering wheel. The play should be as small as possible, but care must be taken to allow the front wheels to resume their straight-ahead position, after the

car has taken a turn. As special experience is needed to properly service this unit, all operations or adjustments required should only be performed by an Authorised VW Service Station. If, however, a workshop is out of reach, proceed as follows:

- 1 - Turn the front wheels to the straight-ahead position.
- 2 - Loosen lock nut and sector shaft adjusting screw on top of the steering gear case.
- 3 - Adjust worm shaft end play: Loosen



adjusting sleeve clamping screw and tighten adjusting sleeve clockwise until the worm shaft end play is taken up. Tighten adjusting sleeve clamping screw.

- 4 - Adjust sector shaft end play: Tighten adjusting screw as far as it will go and back it off $\frac{1}{8}$ turn.
- 5 - The adjusting nut is to be secured in position by the lock nut after the adjustment has been completed.
- 6 - After having completed adjustments with the car supported on trestles, check the steering for binding by turning the steering wheel in both directions as far as it will go.

The maintenance service provides the regular adjustment of the torsion arm link pins on the front axle. After this operation it is absolutely necessary to check the toe-in of the front wheels.

Front Wheel Bearings

The front wheel bearings will occasionally require adjustment. We recommend to refer this operation to an Authorised VW Service Station, as mal-adjustment may cause severe damage to the bearings.

If circumstances require a removal of a front brake drum, the front wheel bearings are to be adjusted as outlined below:

Tighten inner nut until the thrust washer just allows to be moved laterally by a screwdriver and no bearing play can be felt when rocking the brake drum. Too loose or too tight an adjustment may ruin the bearings in a short time.

Finally, secure the nuts by bending down the lock plate.



Convertible Door Windows

A vertical adjustment of the door windows on Convertibles is possible by stop screws, which are accessible by removing the door trim panels. The lock nut of the stop screw is to be loosened before an adjustment is made.

GENERAL DESCRIPTION

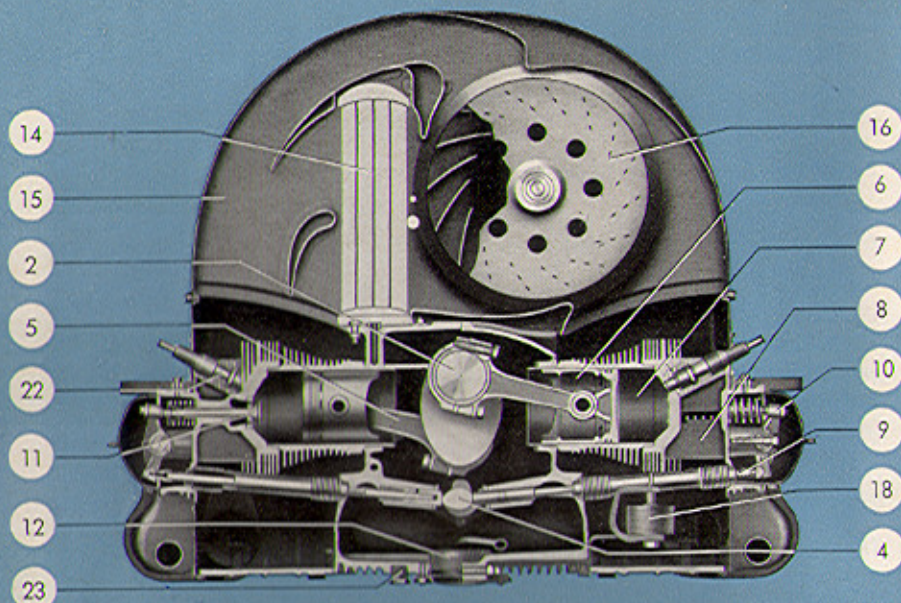

Engine

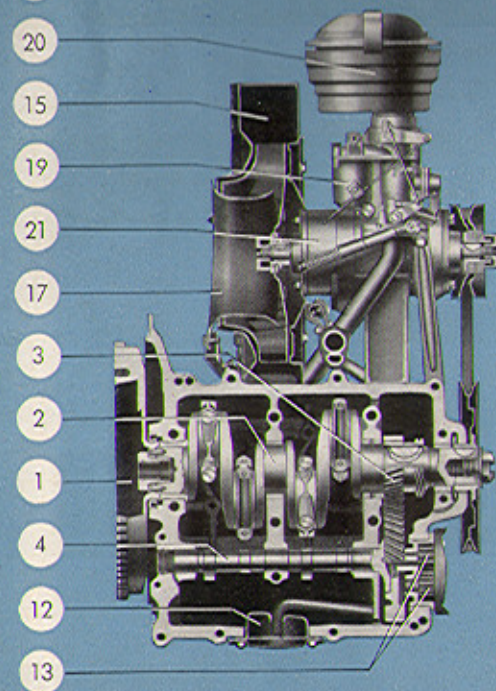

- 1 Flywheel
- 2 Crankshaft
- 3 Crankshaft Timing Gear
- 4 Camshaft
- 5 Connecting Rod
- 6 Piston
- 7 Cylinder
- 8 Cylinder Head
- 9 Valve Push Rod
- 10 Rocker Arm
- 11 Valve
- 12 Oil Strainer
- 13 Oil Pump
- 14 Oil Cooler
- 15 Fan Housing
- 16 Fan
- 17 Throttle Ring
- 18 Thermostat
- 19 Carburetor
- 20 Air Cleaner
- 21 Generator
- 22 Spark Plug
- 23 Oil Drain Plug

Engine

The engine, located in the rear of the car, is mounted in a floating way on the recessed flange of the rubber-cushioned transmission case. Two pairs of cylinders are horizontally opposed. Each pair has one mutual cylinder head made of light alloy. The overhead valves are located in the cylinder head and are operated by means of push rods and rocker arms. The short and counter-balanced crankshaft rests in four replaceable special light alloy bearings and is heat-treated at its four points of support. It drives the camshaft by means of helical gears. The connecting rods are fitted with interchangeable steel-backed lead-bronze bearings. The pistons are made of aluminium alloy.

A down-draft carburetor with accelerator pump produces the fuel-air mixture to supply the cylinders. The engine is equipped with battery ignition.

The spark advance is controlled automatically in two ways, by a centrifugal advance mechanism and a vacuum advance mechanism to assure proper functioning of the ignition under all operating conditions.

The oil pump of the full pressure lubrication is driven by the camshaft and sucks the oil from the crankcase through a strainer, from where it will reach the points of lubrication via an oil radiator. In cold weather, when the oil is of higher viscosity, an oil pressure relief valve makes it possible for the engine to be lubricated directly, that is, by avoiding the oil cooling system. The air cooling of the engine is done by means of a fan, which is attached to the extended generator shaft and driven from the crankshaft by an adjustable V-belt. The fan sucks in air through an opening in the fan housing, and the air cools the engine by passing through fins. An automatic cooling air regulation by thermostat insures well-balanced operating and heating temperatures.

Chassis

The frame of the VOLKSWAGEN is of pressed steel. The steel floor of the frame is formed in two pieces. These two pieces are spot welded together with the channel-shaped center section of the frame, the forked rear end of which serves to support the transmission and engine assembly. The following units pass through the center of the frame:

Gearshift rod, hand brake linkage, fuel line, and, in conduit tubes, the cables of brakes, clutch, throttle, choke, and warm-air heating unit.

The front suspension is an independent parallel arm type, using torsion bar springs. The front axle is bolted to the front end of the frame and consists of two rigidly joined tubes, which carry the torsion bar springs and the upper and lower arms

of the front wheel suspension. The rear axle is of the swinging half axle design. The rear wheels likewise are independently sprung, using one individual torsion bar spring on each side. Double-acting hydraulic shock absorbers in front and rear prevent rebound.

Transmission and rear Axle

Power from the engine is transmitted to the gears via a dry single-disc clutch. The transmission case incorporates four speeds forward, one reverse, and the differential.

The **De Luxe** and the **Convertible** are equipped with synchromesh devices for the 2nd, 3rd, and 4th gears. The gears are helically cut to provide silent operation.

With the Standard Model — without synchromesh — the gears of the 3rd and 4th speeds are in constant mesh to provide silent operation.

The drive pinion and the ring gear are cut spirally. The two swinging rear axle shafts are flexibly supported in the differential housing.

Brakes

The De Luxe and the Convertible are equipped with direct acting hydraulic brakes operating on all wheels. An additional hand-operated brake is provided for use when the car is parked. The hand brake operates the rear wheel brake shoes through cables. The Standard Model is equipped with mechanical brakes. The foot brake and the hand brake both operate on all wheels through mechanical linkage and cables that pass through conduit tubes for greater protection against the weather.

Body

The basic structure of the VOLKSWAGEN is made of formed steel panels, electrically-welded together and strongly reinforced to provide maximum rigidity. Draughtless ventilation by means of vent wings is provided on both door windows. Both front seats can easily be adjusted (De Luxe and Convertible). The front hood lock is released by pulling at a knob. The fuel tank and the spare wheel are located underneath the front hood. Luggage space is provided behind the rear seats and under the front hood.

Heating System

Heated air, which is taken from the air flow warmed up the engine, is emitted through two openings near the floor. For defrosting, two ducts direct heated air to nozzles at the windshield. The heating system can be controlled from the driver's seat by means of a rotary knob situated behind the hand brake lever.

Transmission (De Luxe and Convertible)

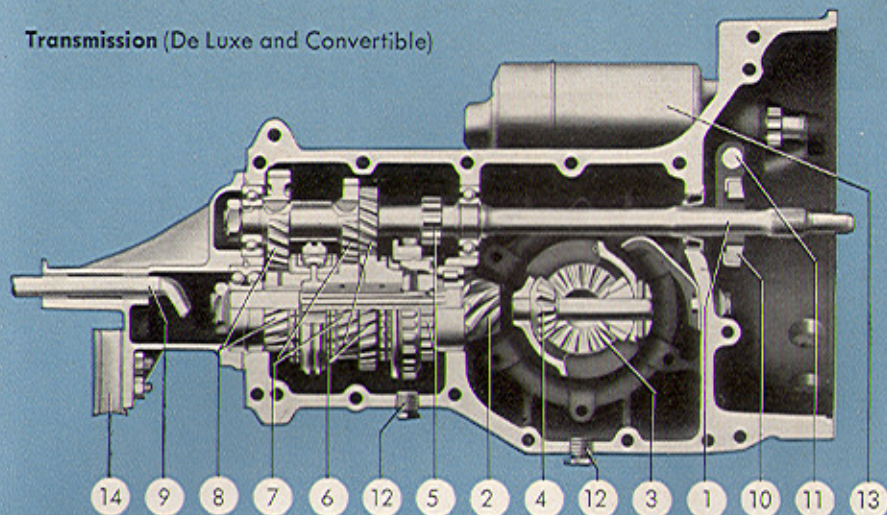

Rear Axle and Transmission (Standard)

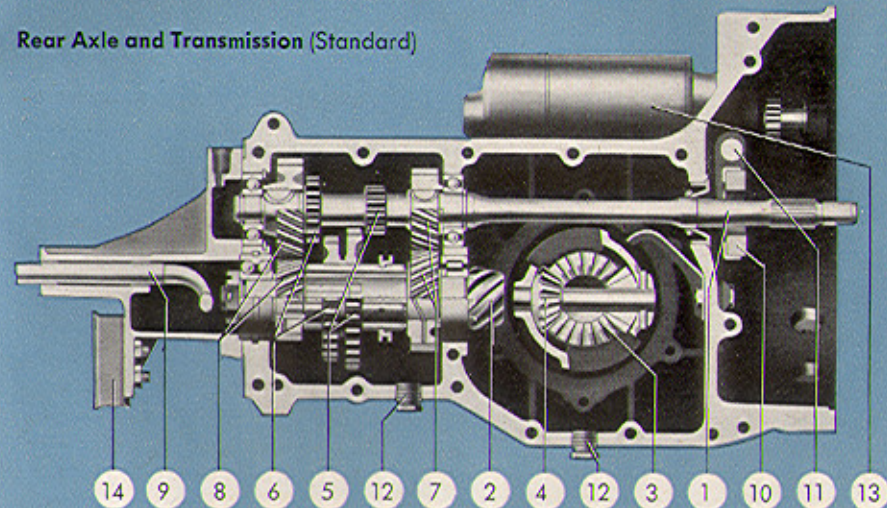

- | | | |
|--------------------------|---------------------------|----------------------------|
| 1 Main Drive Shaft | 6 2nd Speed | 11 Clutch Operating Shaft |
| 2 Drive Pinion | 7 3rd Speed | 12 Oil Drain Plug |
| 3 Differential Side Gear | 8 4th Speed | 13 Starting motor |
| 4 Differential Pinion | 9 Transmission Shift Rod | 14 Rubber mounting cushion |
| 5 1st Speed | 10 Clutch Release Bearing | |

TECHNICAL DATA

Engine

Design	4 Cylinder, 4 Cycle, O.H.V.-Type, in rear of car	
Arrangement of Cylinders	Horizontally opposed (Flat Four)	
Bore	77 mm. (3.031")	
Stroke	64 mm. (2.520 in.)	
Capacity	1192 c.c.	
Compression Ratio	6.6	
Valve Clearance	Intake 0.10 mm. (.004")	} to be adjusted when Engine is cold
	Exhaust 0.10 mm. (.004")	
S.A.E. Rating	36 HP. at 3700 R.P.M. (= 30 B.H.P. at 3400 R.P.M.)	
Lubrication	Force Feed (Gear Pump) with Oil Cooler	
Oil Capacity	Metric—2.5 litres U.S. —5.3 pints Imp. —4.4 pints	
Fuel Pump	Diaphragm Type	
Carburetor	Down-Draft Type, Solex 28 PCI	
Cooling System	Air Cooling by Fan, Thermostat-controlled	
Battery	6 Volts, 66 Ampere Hours	
Starting Motor	Electric, 6 Volts, .4 HP.	
Generator	Voltage regulated, 6 Volts, 160 Watts at 2500 R.P.M.	
Ignition Distributor	Centrifugal and Vacuum Spark Advance	
Firing Order	1—4—3—2	
Breaker Points Open	7.5° before T.D.C.	
Breaker Point Gap	0.4 mm. (.016 in.)	
Spark Plugs	Bosch W 225 T 1 Beru K 225/14 u 2 Lodge H 14 or HN Champion L 10 S, AC F 10 Auto-Lite AE 6 or AER 6 KLG F 70	} 14 mm.
Spark Plug Gap	0.6 to 0.7 mm. (.024" to .027")	

Clutch

Design	Single Disc, dry
Pedal Free-Play	10 to 20 mm. (1/2—1")

Transmission

4 Speeds Forward, 1 Reverse

De Luxe and Convertible: 2nd, 3rd, and 4th Speeds Synchronized and Silent.

Gear Ratios	First	3.60 : 1
	Second	1.88 : 1
	Third	1.23 : 1
	Fourth	0.82 : 1
	Reverse	4.63 : 1

Standard Model: 3rd and 4th Gears Silent.

Gear Ratios	First	3.60 : 1
	Second	2.07 : 1
	Third	1.25 : 1
	Fourth	0.80 : 1
	Reverse	6.60 : 1

Rear Axle

Power is transmitted through spiral drive pinion and ring gear, via two swinging axles to the rear wheels.

Ratio 4.4 : 1

Oil Capacity of Transmission and

Rear Axle	Metric—2.5 litres U.S. —5.3 pints Imp. —4.4 pints
---------------------	---

Chassis

Front Two Square Torsion Bar Springs
Springs, Rear One Round Torsion Bar Spring
on each Side

Shock Absorbers Double Acting Hydraulic Type,
Front and Rear

Steering Worm Steering Gear,
divided Tie Rod

Turns of Steering Wheel, Lock to Lock 2.4

Turning Circle 11 metres (36 ft.)

Wheels Disc Wheels 4 J x 15, Drop-Center Type

Tires 5.60—15

Inflation Pressure

1 to 2 Occupants	Front: 1.1 at. 16 lbs./sq. in.	Rear: 1.4 at. 20 lbs./sq. in.
3 to 5 Occupants	Front: 1.2 at. 17 lbs./sq. in.	Rear: 1.6 at. 23 lbs./sq. in.

Wheel Base 2400 mm. (7 ft. 10.5 in.)

Track Front: 1290 mm. (4 ft. 3 in.)
Rear: 1250 mm. (4 ft. 1.2 in.)

Toe-in (car unladen) 1 to 3 mm. (0.04 in. to 0.12 in.)

Brakes

De Luxe	Foot Brake	Hydraulic Brake, Operating on All Wheels
	Hand Brake	Mechanical, Operating on Rear Wheels
Standard Model	Foot and Hand Brake	Mechanical, Operating on All Wheels

Dimensions and Weights

Length	4070 mm. (13 ft. 4 in.)	
Width	1540 mm. (5 ft. 1/2 in.)	
Height	1500 mm. (4 ft. 11 in.)	
Road Clearance	172 mm. (6.8 in.)	
Net Weight	Sedan	Convertible
Weight incl. Spare Wheel and Accessories	710 kg.	780 kg.
Maximum Load	380 kg.	360 kg.
Permissible total Weight	1110 kg.	1160 kg.

Fuel Consumption

Nominal Consumption on normal Roads	Metric — 7.5 litres per 100 km. U.S. — 32 miles per gallon Imp. — 38 miles per gallon
Fuel	Octane Number 74 (Res. F 1)
Oil Consumption	Between 0.03 and 0.1 liter per 100 km.

Capacities

Fuel Tank	40 liters	(10.5 U.S. gall.; 8.8 Imp. gall.)
Engine	2.5 liters	(5.3 U.S. pints; 4.4 Imp. pints)
Rear Axle and Transmission	2 liters/Refilling quantity	(4.2 U.S. pints; 3.5 Imp. pints)
Steering Gear Case	0.125 liter	(0.26 U.S. pints; 0.22 Imp. pints)
Brake	0.25 liter	(0.5 U.S. pints; 0.4 Imp. pints)
Air Cleaner	0.25 liter	(0.5 U.S. pints; 0.4 Imp. pints)

Performance

Maximum and Cruising Speed	110 km. (68 m.p.h.)				
Hill-Climbing Ability	First Speed	De Luxe Model	37% (20.5°)	Standard Model	37% (20.5°)
	Second Speed	18.5%	(10.5°)	20.5%	(11.5°)
	Third Speed	11%	(6.5°)	11%	(6.5°)
	Fourth Speed	6%	(3.5°)	6%	(3.5°)

MAINTENANCE CHART

At km./miles	km./miles		Operation	Every	
	500	300			
			Clean air cleaner	5000 km.	
			Check and adjust fan belt		
			Clean carburetor Check carburetor adjustment		
			Check breaker point and ignition timing		
			Check valve clearance		
			Examine battery		
			Check operation of lights, signals, and instruments		
			Check generator		
			Check spark plugs and compression		
			Check front wheel bearings, front suspension, steering, and toe-in		
			Check tire pressures and tighten wheel bolts From 5000 km (3000 miles) onwards, rotate tires	3000 miles	
			Test brakes and check brake fluid level		
			Check tightness and effect of shock absorbers		
			Check clutch pedal clearance		
			Coat weather strips for doors and Convertible windows with talc powder		
			Check automatic cooling air control		
			Inspect rear axle and engine for oil leaks		
			Engine, especially exhaust, car- buretor, intake manifold, and fuel pump		6000 miles
			Chassis, body, front axle, rear axle, and steering		
					Check tightness of nuts and bolts

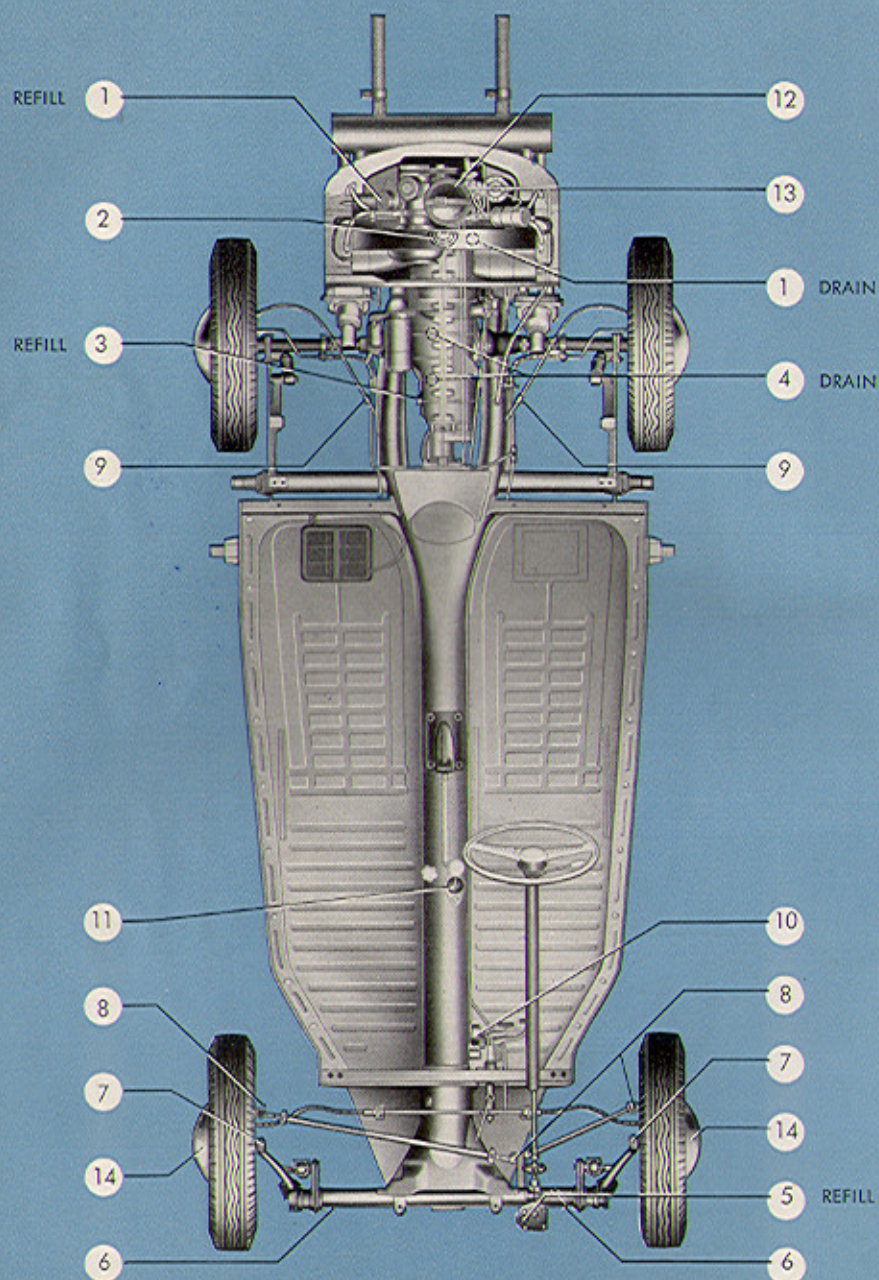

LUBRICATION CHART

At km./miles km. miles 500 300 2500 1500 5000 3000	Lubrication points		Every	
			km.	miles
	Engine: Check oil level, top up if necessary	M	2500 km. 1500 miles	
	6 Front axle tubes	F		
	7 King pins	F		
	8 Tie rod ends	F		
	Door hinges	M		
	1 Engine: Change oil	M	5000 km. 3000 miles	
	3 Transmission: Check oil level	G		
	5 Steering gear: Check oil level	G		
	9 Brake cables	F		
	10 Foot pedal cluster	F		
	12 Carburetor controls	M		
	Door and hood locks	F	10000 km. 6000 miles	
	Convertible: Top linkages	M		
	2 Engine: Clean oil strainer	F		
	11 Gear-shift lever	F	25000 km. 15000 miles	
	13 Breaker arm fiber block in distributor	F		
	4 Transmission: Change oil	G		
	14 Front wheel bearings	F		
	13 Cam bearing in distributor	M		

LUBRICANTS

Lubricant	Lubrication points		Specifications		
			Temperature C	F	
Engine oil	Engine, carburetor controls door hinges, cam hole in distributor, Convertible: Top linkages	M	above +30°	86°	SAE 30
			from -15°	5°	SAE 20 or
			up to +30°	86°	SAE 20 W
			below -15°	5°	SAE 10 W
Gear oil	Transmission case, steering gear	G	SAE 90		
Universal grease	Front axle, tie rod ends, front wheel bearings, brake cables, pedal bearing, gearshift lever, breaker arm fiber block, door and hood locks, Convertible: Door hinges	F	Anti-freeze, water-repellent grease		

INDEX

	Page	Page	
Accelerating — correct and wrong	23	Engine — oil strainer	32
Accelerator pedal	5	— speed	68
— accelerating	23	— sectional view	64
Accessories	III	— technical data	68
Air cleaner — cleaning	47	— type of oil	33/34
Ash receiver	18	Fan belt — adjusting	48
Battery — maintenance	58	— checking tension	10
— care in winter	30	Foot brake — adjusting	60
Body — airing the interior	46	— description	66
— description	66	Front axle — description	65
Brakes — adjusting	60/61	— lubrication	36
— application	16	— technical data	69
— bleeding	59	Front seats — adjustment	16
— care in winter	30	— lubrication of seat runners	38
— checking	11	Front wheel bearings — adjusting	63
— description	66	— lubrication	36
Brake pedal	5	Fuel consumption	70
Breaking-in (running-in) period?	22	Fuel tank — capacity	10/70
Carburetor — adjusting	50	— reserve	10
— cleaning	49	Fuel tap positions	10
— type	68	Fuse boxes	54
Care of the car	41	Fuses — exchanging	55
Chassis — care in winter	30	Gearshift lever	6
— description	30	Gear shifting on gradients	23
Chassis number	8	Generator	68
Choke control knob	6	Ground clearance	70
— application	13	Hand brake — adjusting	61
Chromium-plated parts — care	45	— description	66
Climbing ability	70	Headlights — aiming	56
Clutch — design	68	— changing bulb	55
— pedal	5	Heating — description	66
— pedal free play	68	— operation	29
Controls — driver's	5	Hood lock — control knob	6
Cooling of engine	68	— Convertible	18
Dimensions — overall	70	Horn button	6
Dimmer switch — headlight	5	Idling — checking and adjusting	50
Direction indicator switch	6	Ignition — breaker point gap	53
Doors — care of weather strips	46	— distributor	68
— inside handle	6	— firing order	68
— lubrication points	37	— lubrication of distributor	34
Driving away	14	— timing	53
Driving down-hill	16	Instrument light	12
Economy	23/24	Interior light	18
Engine — compression ratio	68	Jack — application	40
— description	65	— location	19
— design	68	Key — doors and ignition	8
— lubrication (oil change)	31	License plate light — replacing bulb	57
— oil change in winter	29		
— oil level	10		

	Page	Page	
Light switch — positions	12	Stop light — bulb replacement	57
Lubricants	73	— checking	12
Lubrication	31	Stopping the car — generally	16
Lubrication chart	73	— temporarily	26
Maintenance	47	Sun roof — cleaning	44
Maintenance chart	71	— opening and closing	19
Maximum output	68	Suspension — front	69
Maximum speed	70	— rear	69
Model detail plate	8	Tail light — replacing bulb	57
Non-skid chains	30	Technical data	68
Oil consumption	70	Tires — inflation pressure	11
Oil level — engine	10	— maintenance	39
— steering gear	35	— M + S tires	30
— transmission	35	— size	69
Paintwork — preservation	42	— wear	39
— polishing	43	Toe-in of front wheels	69
Parking your car	27	Tools and accessories	III
Passing other cars	26	Track (tread)	69
Practical driving	22	Transmission — description	66
Ratios — rear axle	69	— oil change and capacity	29/34
— transmission	69	— sectional view	67
Rear axle — description	66	— technical data	69
— technical data	69	Turning circle	69
— transmission of power	69	Type of fuel	11
Rear seat back	17	Upholstery — care of cloth	45
Rear view mirror	26	— imitation leather	46
Reverse gear	14	— leather	46
Safety in traffic	26	Valves — adjusting	51
Seat adjustment	16	— arrangement	68
Sectional view with explanations	76	— clearance	68
Shifting gears	14	Vent wing	6
Shock absorbers — design	69	Warning lights — direction indicator	25
Spare wheel	39	— generator and cooling	25
Spark plugs — checking and cleaning	52	— headlight	25
— gap	52	— oil pressure	25
— removal	52	— replacing bulbs	57
Speedometer	5	Washing your car	41
Speed ranges	22	Weights	70
Spots removal	44	Wheel base	69
Starting — danger in closed rooms	13	Wheels — balancing	39
— in winter	13	— changing	39
— with engine cold	13	— rim size	69
— with engine hot	13	Window regulator — lubrication	37
Starting motor	68	Window regulator handle	6
Steering — adjusting	62	Window weather strips — care	46
— type	69	Windshield wiper switch	6
Steering wheel	6	Winter service	28

VW SEDAN, SECTIONED

- 1 Spare wheel
- 2 Brake fluid reservoir
- 3 Steering gear
- 4 Front axle and square torsion bars
- 5 Fuel tank
- 6 Fuel tap
- 7 Brake master cylinder
- 8 Pedal linkage
- 9 Speedometer
- 10 Gearshift lever
- 11 Heat control
- 12 Direction indicator switch
- 13 Hand brake lever
- 14 Vent wing handle
- 15 Battery
- 16 Socket for car jack
- 17 Rear torsion bar
- 18 Transmission
- 19 Starting motor
- 20 Differential
- 21 Shock absorber
- 22 Clutch
- 23 Crankshaft
- 24 Camshaft
- 25 Oil strainer
- 26 Fan housing
- 27 Oil pump
- 28 Muffler (Silencer)
- 29 Generator
- 30 Carburetor
- 31 Oil bath air cleaner

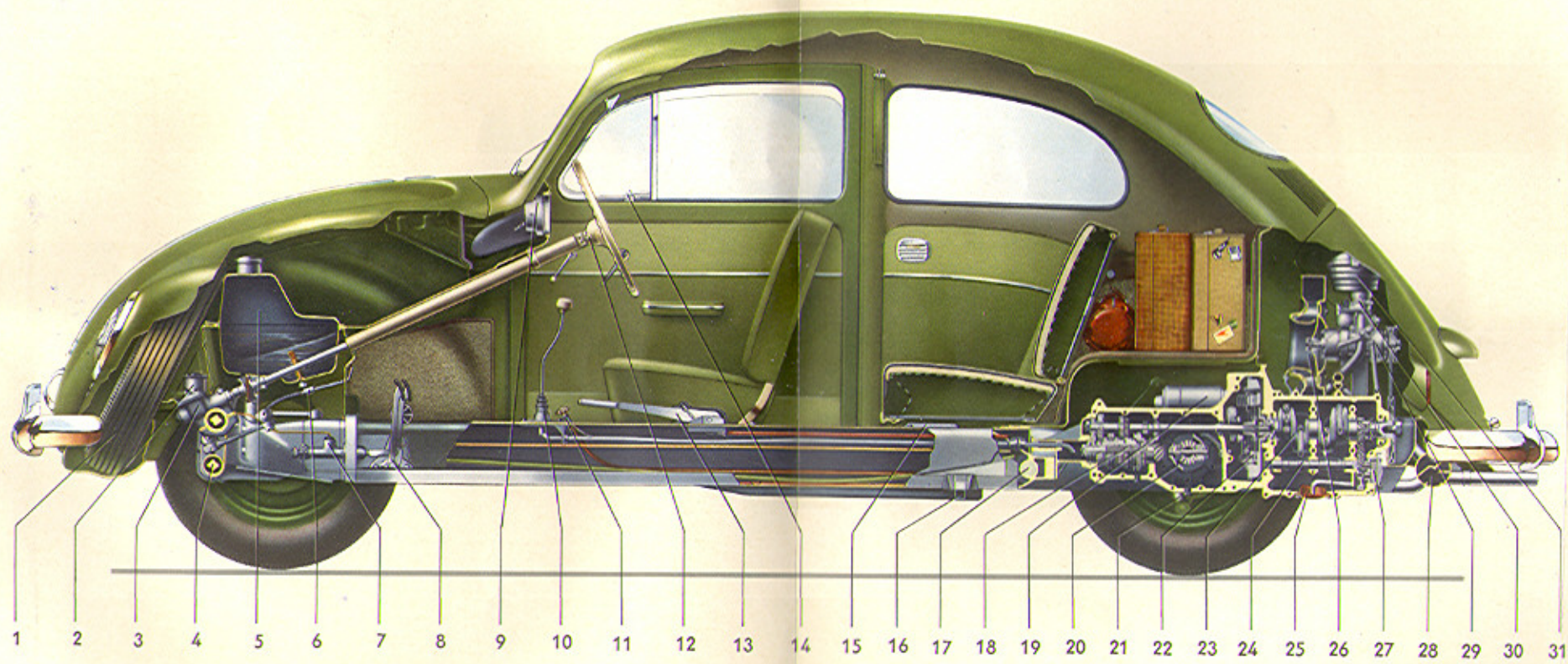

- 1
- 2
- 3
- 4
- 5
- 6
- 7
- 8
- 9
- 10
- 11
- 12
- 13
- 14
- 15
- 16
- 17
- 18
- 19
- 20
- 21
- 22
- 23
- 24
- 25
- 26
- 27
- 28
- 29
- 30
- 31

Tools and Accessories

- 1 Fan Belt
- 1 Tool Roll
- 1 Spare Wheel, complete
- 1 Jack
- 1 Combination Pliers
- 1 Screwdriver 0.8 mm.
- 1 Screwdriver 0.5 mm.
- 1 Open End Wrench 8/12 mm.
- 1 Socket Wrench for Spark Plug, Wheel Disc Bolt
- 1 Socket Wrench 14 mm.
- 1 Rod for Socket Wrench and Jack

The VOLKSWAGENWERK G. m. b. H.
reserves the right to make any changes in or improvements on its products
without imposing any liability or obligation upon itself to install
them on its products previously manufactured.
All rights reserved in accordance with the law of copyright