

# Instruction Manual

1967

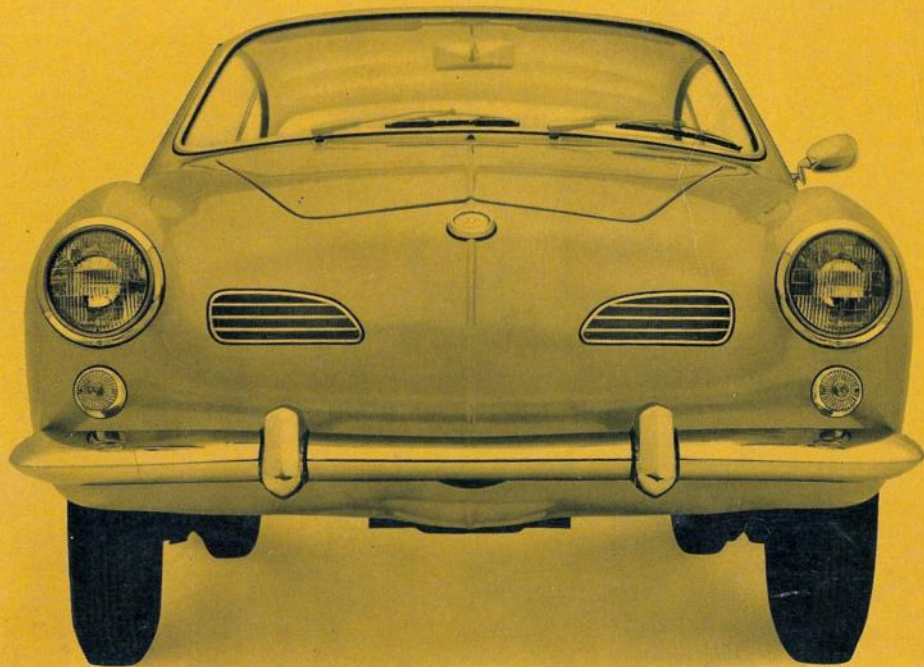

# **Instruction Manual and Service Card**

**VW 1500 Karmann Ghia**  
**Coupé and Convertible**

**August 1966**

**VOLKSWAGENWERK AKTIENGESELLSCHAFT · WOLFSBURG**

**is advisable . . .**

to read the first part of this instruction manual, which deals with the operation of your Volkswagen, very carefully. You will then get to know your new car quickly and will be able to start off on your first trip with complete confidence.

Everything about winter driving, tips on care of the vehicle and numerous points on carrying out small repairs and adjustments are given in the second half of this manual. This part also contains information on lubrication and maintenance and some interesting technical data.

At the back of the book is the service card, the warranty voucher and terms of warranty and a voucher for the free-of-charge maintenance service. The stamps in the squares show you that the lubrication and maintenance services have been carried out regularly by a VW Dealer.

### **Only one key**

is required to open the door and start the engine. It is a good idea to note the number of the key on a slip of paper which is then put with the vehicle documents. If you should lose the key, you can always obtain a replacement from your VW Dealer.



## Sit down and make yourself comfortable . . .

When driving, you must be comfortable. That is why the Volkswagen has separate front seats which are built so that you can alter seat position and backrest rake to suit your requirements. This is quite simple — just lift the lever at the front right-hand side of the seat and slide the seat forward or backward. When the seat has been moved, always en-

sure that the lever engages properly so that the seat cannot move of its own accord while you are driving.

The runners are slightly inclined so that the seat is raised as it goes forward.

The backrest rake can also be set to various angles. Try them out until you find the angle which suits you best.

When the doors are closed, cable-operated catches on each side prevent the backrests from tilting forward. If a seat is to be removed, the cable must be disconnected on the inner side of the seat first before the seat is pushed forward out of the runners.

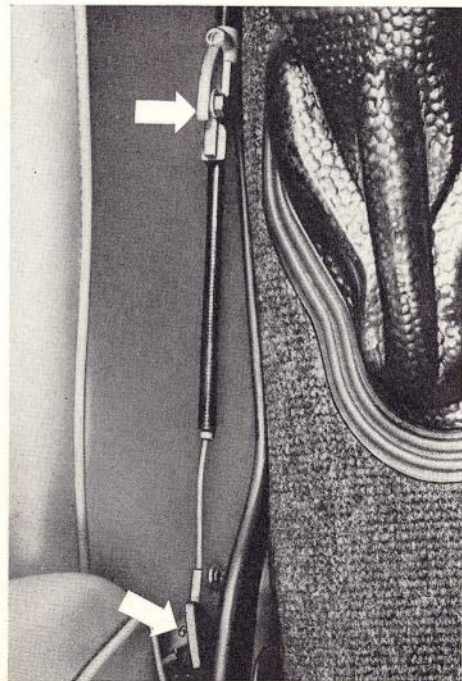
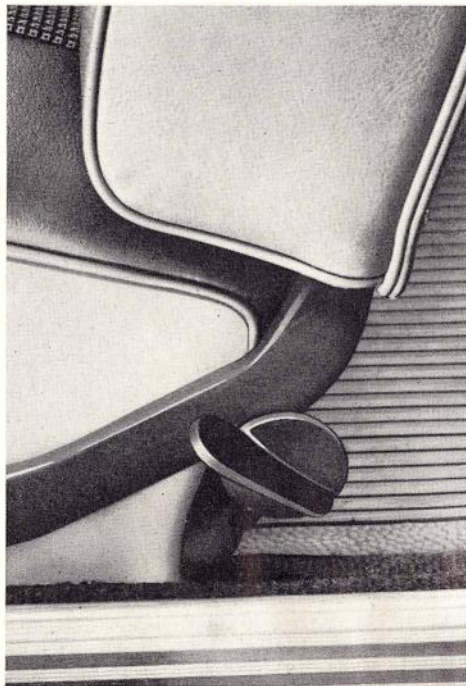
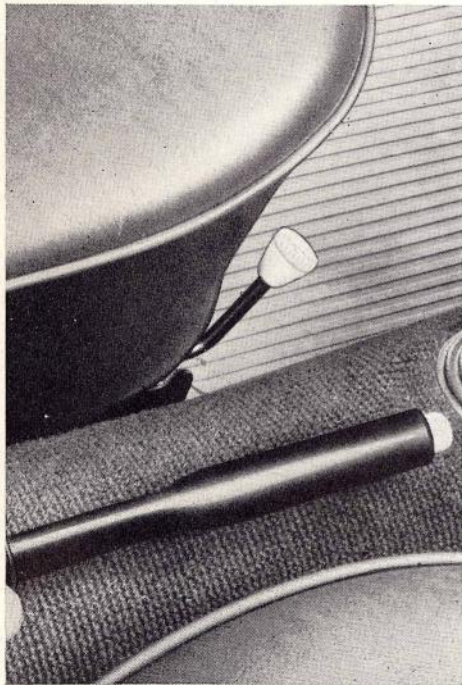

## Before closing the door from inside . . .

it is advisable to open a window slightly. The door will then be easier to close because the air can escape from inside the body.

- 1 — Locking lever
- 2 — Window crank
- 3 — Armrest and door closing grip
- 4 — Safety knob for lock

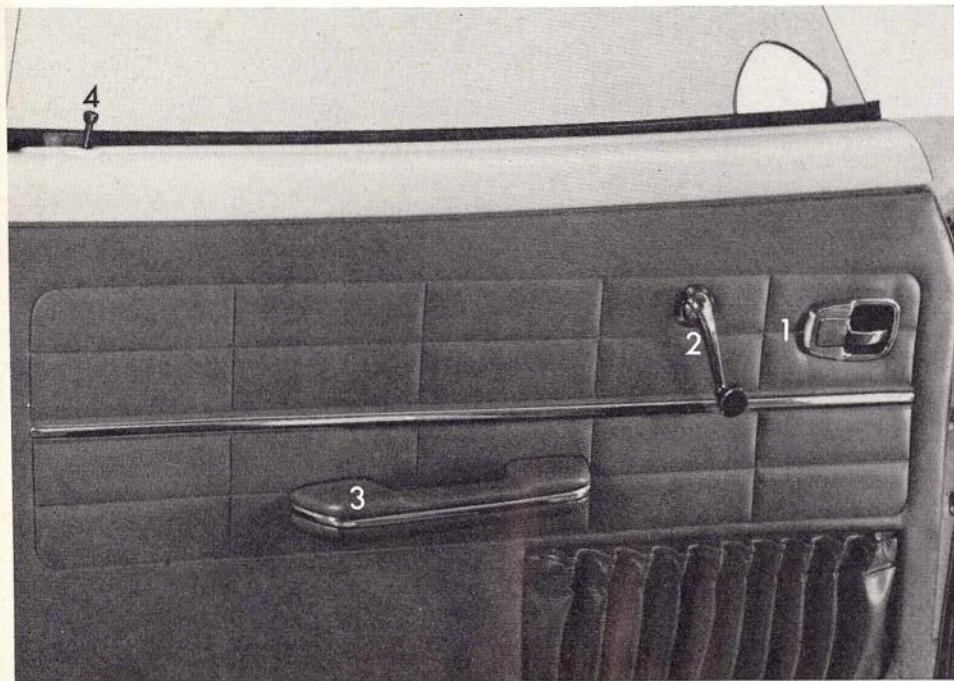

The doors cannot be opened from inside with the locking lever until the safety knobs have been lifted.

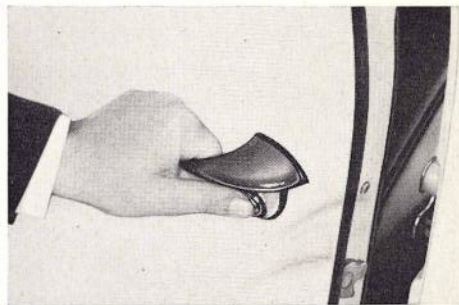

When leaving the vehicle, just press the safety knob down and depress the button under the outer handle as you close the door. The vehicle is then locked.

If the door closes on its own after the safety knob has been depressed, it will not lock itself because the safety knob springs up automatically. This is an additional safety measure to prevent you from being locked out if the door should slam to while the key is still inside the vehicle.

## In front of you - the instrument panel

Even if it is not your first Volkswagen, just have a quick look at the dash and try out the various knobs and levers with the ignition switched on:

### 1 — Speedometer

The following warning lamps are in the speedometer dial:

- green — oil pressure
- red — generator and cooling
- blue — headlamp high beam
- green arrows — turn signals

### 2 — Fuel gauge

When the needle is on the "R" mark there are about 5 liters (1 gallon) of fuel left in the tank — time to refuel at the next opportunity.

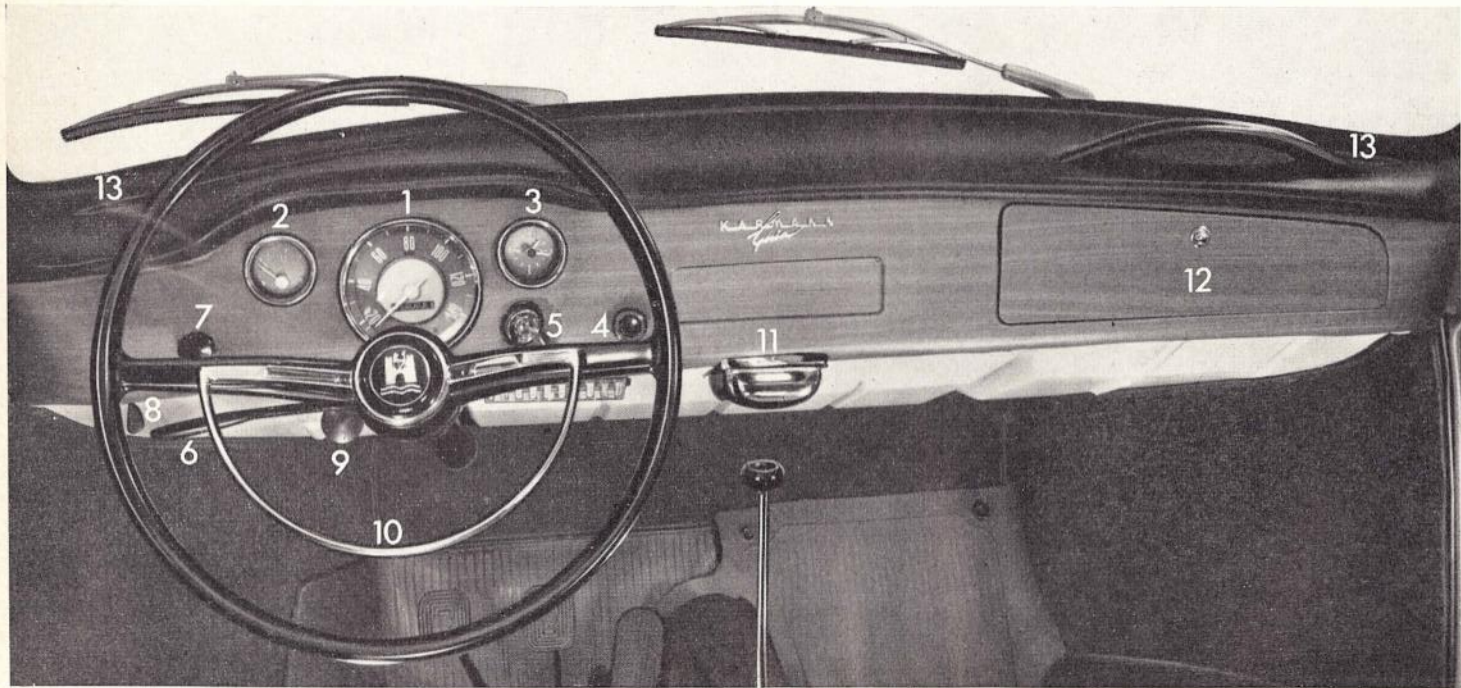

### 3 — Clock

The clock is electrically operated. The hands can be set by pressing in and turning the knob in the center of dial.

### 4 — Windshield wipers and windshield washer system

The two-speed wipers are switched on by turning the switch. They park automatically when switched off. The button in the switch knob controls the windshield washer.

### 5 — Steering / ignition lock

- 1 — Ignition off — Steering locked
- 2 — Ignition off — Steering free
- 3 — Ignition on
- 4 — To start

#### Important

Remove key from lock only when vehicle is stationary.

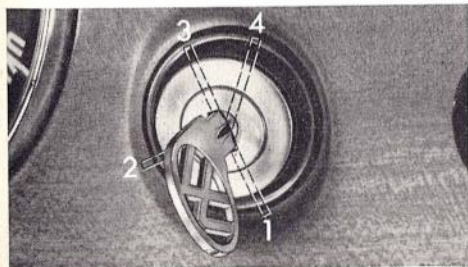

### 6 — Turn signal switch

- Lever up — right turn signal
- Lever down — left turn signal

The turn signals are cancelled automatically after taking the corner. The small button in the lever switches the headlamp beams up and down. A blue warning light in the speedometer dial shows when the headlamp high beams are switched on. In the daytime, the button serves as a **headlamp flasher**.

### 7 — Lighting switch

Pull the knob out to the first stop to switch on the parking, license plate and tail lights. Pulling the knob out to the next stop, switches the headlamps on as well.

**The instrument lights** are switched on and the brightness controlled by turning the lighting switch.

### 8 — Fresh air ventilation

The two levers on the lower edge of the instrument panel control the flow of fresh air

- A — on
- B — off

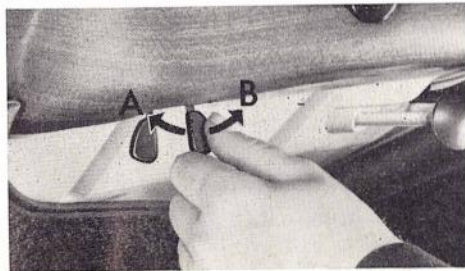

separately for each side through the defroster vents at the bottom of the windshield.

By operating the heating and the fresh air ventilation at the same time you can admit a mixture of warm and fresh air into the vehicle interior.

### 9 — Knob for front hood

To close the front hood, just press it down firmly until you hear it click.

On the Convertible, the knob is lockable so that luggage, spare wheel and fuel cannot be interfered with by unauthorized persons when the top is open.

### 10 — Horn ring

### 11 — Ashtray

To remove ashtray, press leaf spring down and pull ashtray out.

### 12 — Glove compartment

Press the knob to open the glove compartment lid. On the Convertible, the knob is lockable.

### 13 — Defroster vents

## Above the windshield

### 14 — Sun visors

You can pull the visors out of the center mounting and swing them towards the door windows to prevent dazzle from the side.

### 15 — Rear view mirrors

Inner and outer mirrors are ball joint mounted so that they can be set to give clear vision to the rear at all times.

On the Convertible the height of the mirror can be altered by turning it 180° so that you can see to the rear properly when the top is open.

### 16 — Interior light

Switch positions:

- Top — Interior light on
- Center — Interior light off
- Bottom — Light only on when doors are open

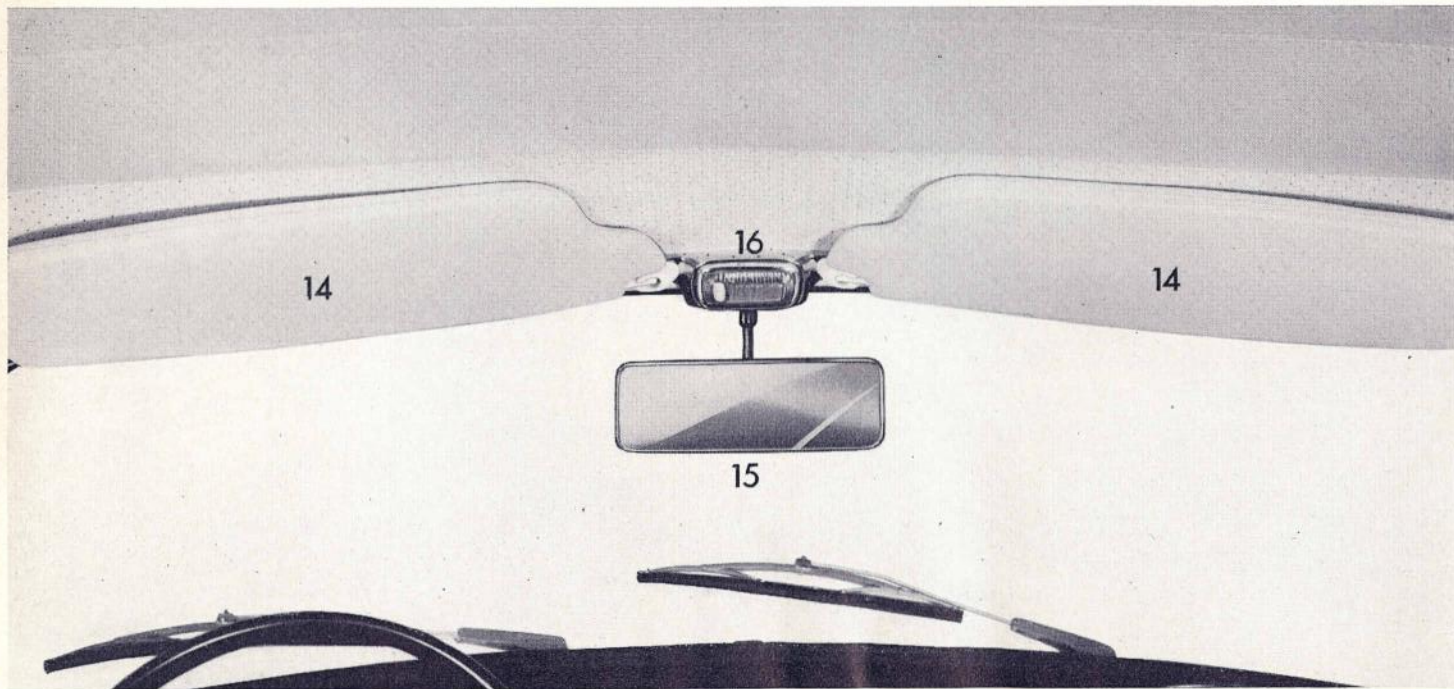



## In the footwell and between front seats

17 — Clutch pedal

18 — Brake pedal

19 — Accelerator pedal

20 — Gearshift lever

21 — Handbrake

To release the locking knob, pull the lever up slightly first.

22 — Heating control levers

Lever up — heat on  
Lever down — heat off

The heating output will be more effective if you open one of the vent wings slightly when the heating is on because the fan can then force the warm air into the body interior more easily.

23 — Control lever for heating in rear footwell

This lever controls the flow of warm air into the rear footwell when the heating is on.

Lever up — flaps open  
Lever down — flaps closed

At low temperatures it is advisable to leave the rear outlets closed when first moving off. This increases the flow of air to the windshield and also helps to prevent steaming up when the air humidity is high. As soon as the windshield is clear, the rear footwell outlets should be opened so that the interior of the body heats up as quickly and uniformly as possible.

24 — Heater control slides in front footwell

The flow of warm air into the front footwell can be controlled separately on each side by means of slides over the outlets.

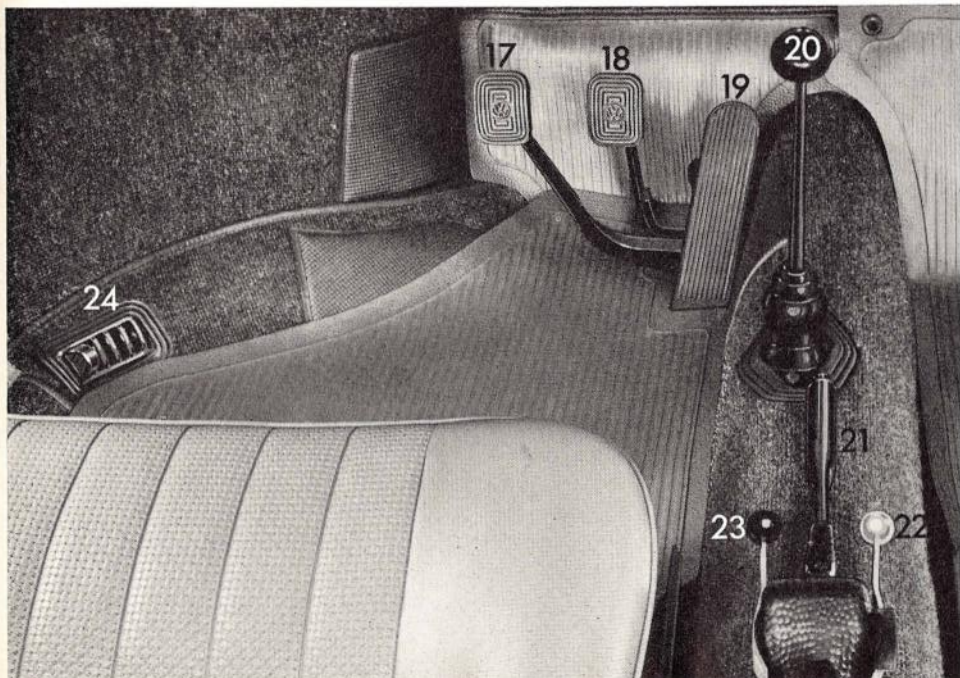

## Behind you . . .

### 25 — Rear luggage compartment

There is a second luggage compartment behind the emergency seat. To stow luggage, just fold the backrest forward. The backrest can be fixed down if you wish to carry a lot of luggage. In the normal position the backrest is retained by a rubber loop.

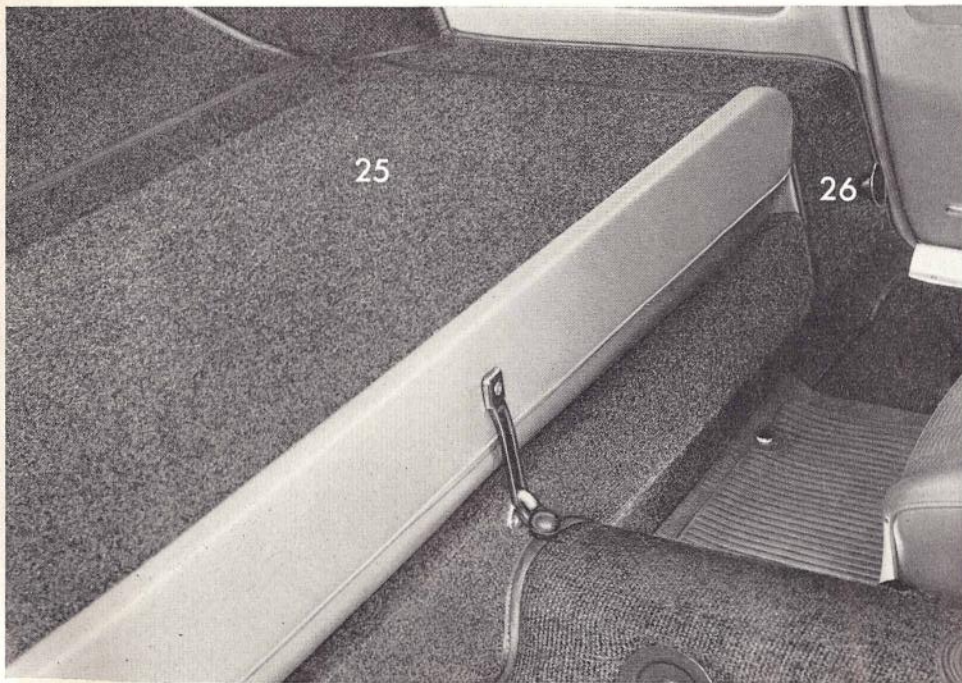

### 26 — Knob for engine compartment

The lid for the engine compartment is unlocked with the knob near the left lock pillar. The lid is held in the open position by springs. To close the lid, press down on the license plate lamp housing until you hear a click.

### 27 — Hinged quarter window

The windows can be opened as required after releasing the fastener.

### 28 — Coat hooks



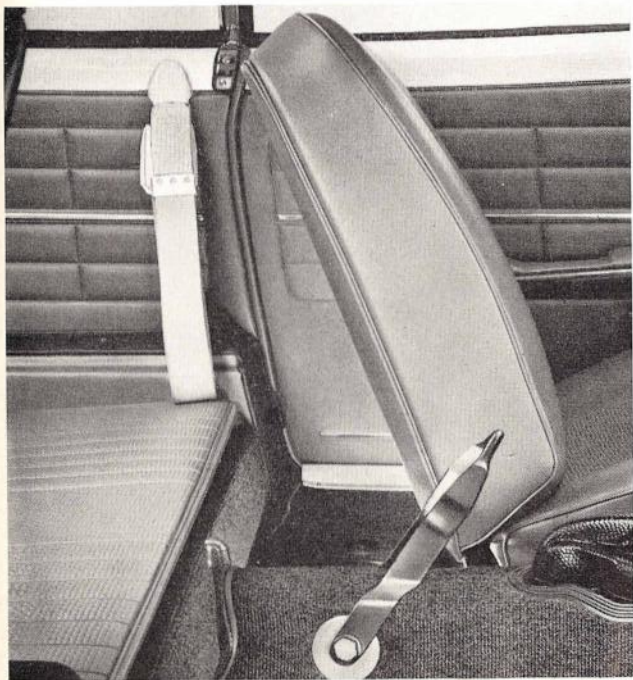

**Safety belts** can be obtained from every VW Dealer. The mounting points are on the lock pillar and on the side on the frame tunnel in the rear footwell.

**Now let us have a look . . .**

## ... in the front luggage compartment

Whether you are taking a lot of luggage with you or not, please load the front luggage compartment first, using the heaviest pieces of luggage. A good load distribution means good roadholding so take advantage of the possibilities offered by the Volkswagen with its two luggage compartments.

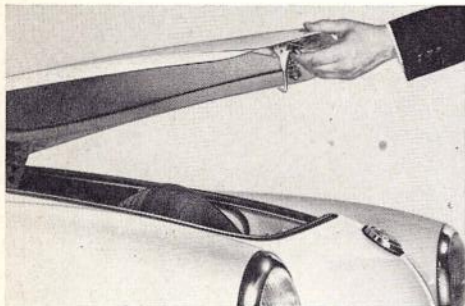

The knob which opens the front hood is on the left under the instrument panel. The hood springs up slightly first under spring pressure and can be opened fully when the safety hook near the lock has been pressed back.

To close the hood, press it down firmly until you hear a click. Never try to close the hood by pressing at the side, always press it in the center near the lock.

### 29 — Container for windshield washer

The container can be filled with water until it overflows. There is always room for sufficient air to operate the washer. The correct air pressure is  $2.5 \text{ kg/cm}^2$  (35 psi). It is advisable to add a cleaning solution to the water as clear water alone is usually not

adequate to ensure that the windshield is cleaned quickly and properly. If enough of this cleaning agent is put in, it also acts as an anti-freeze solution in the winter. Details of the mixing proportions are given in the list of cleaning materials on page 25.



Methylated spirits can also be used as an anti-freeze agent. In this case a mixture of 1 part meths to 3 parts water will protect the water from freezing down to about  $-12^{\circ}\text{C}$  ( $10^{\circ}\text{F}$ ).

### 30 — Brake fluid reservoir

The container must be at least three quarters full. If this is not so, have your VW Dealer check the brake system.

### 31 — Fuel tank filler

The tank holds 40 liters (10.6 US gallons 8.8 Imp gallons). The choice of fuel is left entirely to you. The Volkswagen will run satisfactorily on all normal commercial fuels which fulfil the octane requirements of the engine (91 octane).

If regular fuels with adequate anti-knock qualities are not available, premium fuels should be used or mixed with the regular fuel.

### 32 — Jack

How you operate the jack is described together with wheel changing on page 29.

### 33 — Spare wheel

Have the air pressure in the spare wheel checked from time to time. Inflate it to  $2.0\text{ kg/cm}^2$  (28 psi) which is the highest pressure you will normally require. It is then easier to lower the pressure when fitting the wheel than to inflate to the pressure required.

### 34 — Tools

In the tool bag you will find

- 1 fan belt
- 1 wheel cap remover
- 1 pair of combination pliers
- 1 screwdriver with reversible blade for slotted and Phillips screws
- 1 open-end wrench 8 mm and 13 mm
- 1 socket for plugs, fan pulley and wheel bolts
- 1 socket wrench 14 mm
- 1 bar for socket wrench (is also used to operate the jack)

## Now you know your vehicle fairly well.

Further hints on what to do before moving off and when on the move are given on pages 17 to 19. If you own a Convertible, read the next page first.

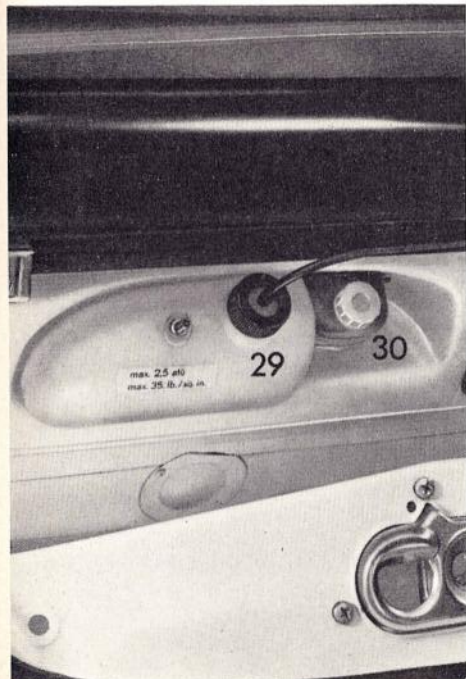

## When the sun is shining . . .



you can open the Convertible top without effort but only open it when it is dry and clean as sharp particles of dirt will damage the material.

First fold the crank down and unlock the top by turning crank one full turn to the right. Then lift the top slightly with the handles. Lay the protective cloth smoothly over the



rear window, and smooth rear window and top material out between the bows while folding the top back slowly.

Before putting on the protective boot and securing it with the press buttons, press the top down lightly on both sides until the small catches engage. The boot should be secured on the inside first and then on the outside.

Please make sure that the top is completely covered by the boot as otherwise there will be friction marks.



## When it rains . . .

you will want to close the top again as quick as possible. Take the protective boot off, press the top down slightly so that the catches can be unhooked and pull the top forward. Pull it down onto the windshield frame with the handles until the locking hooks engage in the recesses. Then lock the top by turning the crank one full turn to the left.

## Before moving off, check . . .

the fuel, the brakes, the lights and, at regular intervals, the oil level in the engine and the tire inflation pressures.

**The fuel** in the tank, when full, is sufficient for 400—450 kms (250—280 miles).

**The brakes** should be applied once or twice just after moving off to see that they are working properly.

**The lights** include headlamps, rear lights, license plate light, turn signals and brake lights.

The turn signals and brake lights must be checked with the ignition on. If a turn signal is defective, the warning lamp in the speedometer dial flashes much quicker than usual. The brake lights only work when the brake pedal is depressed.

**The oil level** should be between the two marks on the dipstick and must never be below the lower mark. Wipe the dipstick clean before checking.

The vehicle must be on a level surface when the oil level is checked otherwise the dipstick reading will be inaccurate. Do not check the oil immediately after stopping the vehicle. Wait at least 5 minutes to give the oil in the engine time to drain down into the bottom of the crankcase.

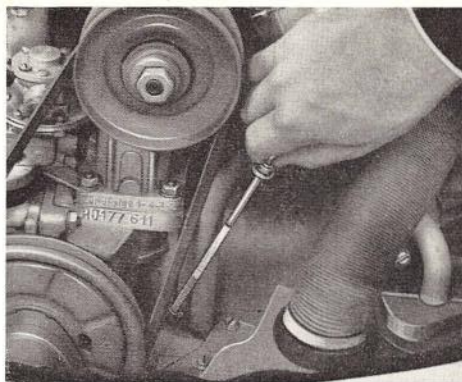

Try to always use the same brand of gasoline engine HD oil. Further details about the viscosity of the oil to be used are given on page 41.

### Tire pressures

	front	rear
with 1 to 2 occupants	1.1 kg/cm <sup>2</sup> (16 psi)	1.7 kg/cm <sup>2</sup> (24 psi)
fully loaded	1.2 kg/cm <sup>2</sup> (17 psi)	1.8 kg/cm <sup>2</sup> (26 psi)

For long, high-speed motorway trips, the tire pressures should be increased by 0.2 kg/cm<sup>2</sup> (3 psi) at front and rear.

### Two more important points:

1—The carburetor of your Volkswagen should draw in preheated air at tem-

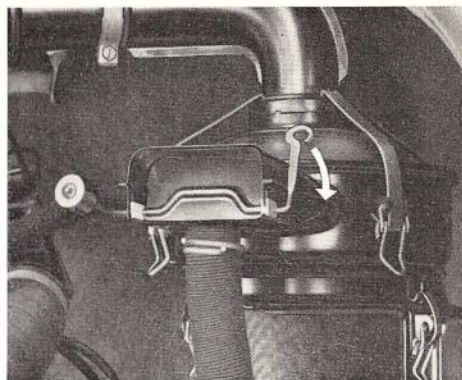

peratures below +10 ° C (50 ° F). This helps to keep down fuel consumption in cold weather and prevent the carburetor icing which sometimes occurs when air humidity is high.

The weighted flap in the air cleaner intake pipe must be free to move in the winter and the cool seasons. If the average temperature is above +10 ° C, the flap must be fixed open by jamming the lever under the ridge on the intake pipe.

2—If the vehicle is used mainly in very dusty conditions, the oil bath air cleaner must be checked frequently, even daily if necessary.

How this is done is described on page 44.

## Starting the engine



Before turning the ignition key, make sure that the gear shift lever is in neutral.

**At temperatures above freezing point** or when the engine is still warm, depress the accelerator pedal slowly while operating the starter. When the engine is very warm, depress pedal fully but do not "pump" it.

**At temperatures below freezing point** or when engine is cold, depress the accelerator pedal fully once and then release it so that the automatic choke can work. Then switch ignition on and start **immediately**. Declutch so that the starter only has to turn the engine.

As soon as the engine starts, release the ignition key so that the starter is switched off.

Do not try to warm the engine up by letting it idle with the vehicle stationary — drive off straight away.

Do not race the engine while it is still cold. If the engine does not start the first time or stalls when declutching, the ignition will have to be switched off and then on again because there is a non-repeat lock in the switch which prevents the starter from being operated when the engine is running and thus being damaged.

**The warning lights** in the speedometer dial which come on when the ignition is switched on, go out when the engine starts:

The red warning light for the generator shows thus that the generator and cooling fan are working.

If this light comes on when you are driving, stop at once and check the belt which drives the generator. When this belt breaks, the engine cooling ceases to work. The proper way to fit a new belt is described on page 31.

If the generator stops charging for any other reason, you can drive on but try to get the vehicle into a workshop as soon as possible because the battery will soon run down.

If the green warning light for the oil pressure comes on while driving, stop at once because the flow of lubricating oil in the engine may have ceased. Check the oil level first. Should the cause of the trouble be elsewhere, you are advised to get expert assistance.

**Be careful when running the engine in confined spaces.** Ensure that there is ample ventilation so that the poisonous exhaust gases can escape.



## ... it runs ... and runs ... and runs ...

You can drive your Volkswagen at full speed from the first day. There are, however, certain permissible speed ranges for the various gears:

1st gear	2nd gear	3rd gear	4th gear
kph 0—25	10—55	30—90	45—132
mph 0—15	6—34	18—56	28—82

When a particular traffic situation makes it essential to move rapidly, you can accelerate up to 60 kph (37 mph) in 2nd gear and up to 95 kph (60 mph) in 3rd gear for brief periods only. Bear in mind, however, that full throttle acceleration puts fuel consumption up considerably. It is more economical to drive smoothly and keep the top speed fairly constant. Very fast, racy-sporty driving, alternating between full throttle and hard braking will mean more frequent visits to a gas station not to mention increased tire and brake lining wear.

You can drive very economically between:

10 and 35 kph in 2nd gear ( 6 and 22 mph)  
30 and 55 kph in 3rd gear (18 and 34 mph)  
45 and 95 kph in 4th gear (28 and 60 mph)

Just a few words about the clutch while we are on the subject of driving. The clutch is a very hard worked part of the vehicle. A good driver slips the clutch as little as possible when moving off and changing gear. He always depresses the clutch fully when changing gear, he changes down into the appropriate gear in queues and city traffic instead of slipping the clutch and never uses the clutch pedal as a "rest" for his left foot.

Shift into reverse gear only when the vehicle is standing still. Reverse gear is fitted with a lock so that it cannot be engaged unintentionally. To engage reverse, press the lever down, move it over to the left and pull it back to the stop.

Volkswagen automobiles have first class brakes which can stop the vehicles in the shortest possible distance. But do not forget that the braking distance increases very rapidly as the speed increases. At 100 kph for example it is four times longer than at 50 kph. Apply the brakes in good time whenever possible but do not use too much force, locked wheels increase the braking distance.

Water reduces the tire adhesion and the coefficient of friction of the brake linings but we cannot do anything about this. You can, however, take care when driving, remain at a safe distance behind preceding vehicle particularly when roads are wet and slippery. Safety first is the motto.

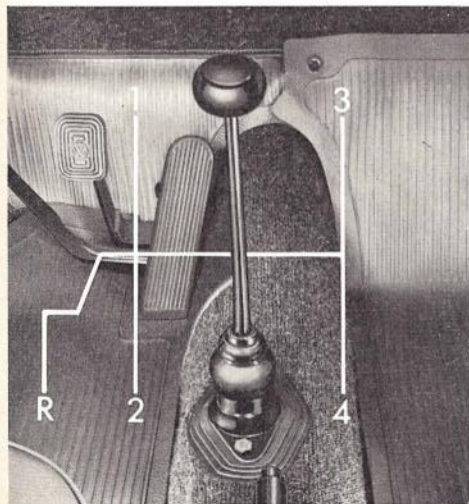

That just about covers the operation of the car and how to drive it properly. The following pages deal with tips for winter driving, breakdowns and all there is worth knowing about the lubrication and maintenance of the vehicle.

## When it snows and freezes . . .

Your car has two features which you will appreciate in the winter: Air cooling and heating. You can leave your car out in the bitter cold without fear — the aircooled engine will always start readily and supply warm air for the interior of the body.

Do not, under any circumstances, try to influence the heating of the vehicle by covering up the slots behind the rear window. These slots must always be clear so that air can flow in to the carburetor and to the engine cooling fan.

**The brakes** may freeze up in the winter if water gets into the drums due to splashing or condensation so leave the car in 1st or reverse gear when parking it and do not apply the handbrake.

When parking on steep hills, turn the front wheels against the kerb as well to stop the vehicle rolling away. If there is no kerbstone, it may be advisable to place a stone or wedge under a wheel.

**Tires** with badly worn treads are very dangerous particularly in the winter so ensure that they are replaced in good time.

M + S tires with special heavy treads give good roadholding in snow and slush. They can be fitted to all four wheels but never use them on the front wheels only.

Better still are M + S tires with spikes which increase the safety margin even on hard snow and ice. These tires should always be fitted on all four wheels. The maximum speed for a vehicle fitted with M + S and M + S spiked tires is 130 kph (80 mph).

The specific characteristics of winter tires can be improved by raising the tire pressures to 0.2 kg/cm<sup>2</sup> (3 psi) above the normal operating pressure for the tire concerned. This inflation pressure then covers the recommended pressure increase of 3 psi for fast highway driving. M + S tires with spikes should be run at moderate speeds when new in order to give the spikes time to settle.

In general, winter tires only have real advantages when conditions on the road are really wintry. For safety reasons, it is not advisable to drive a vehicle fitted with any type of winter tire at top speed. You cannot expect a winter tire to have the same degree of adhesion on dry, wet or snow-free roads as a normal tire. Furthermore, under these conditions M + S tires wear rapidly, particularly at high speeds.

**Snow chains** can be fitted to normal and winter tires on the rear wheels only. Only then chains which do not stand clear of the tire tread and inner side wall more than **15 mm** including tensioner, are suitable. When driving over long stretches of road which are free of snow, the chains should be removed. They serve no useful purpose here but merely damage the tires and wear out quickly.

**Engine oil** of SAE 30 grade will tend to thicken at temperatures around freezing point and may cause difficult starting. As soon as winter temperatures are expected, change over in good time to a thinner grade of engine oil. Details of the various oils to be used are given on page 41.

If you only drive mainly short distances and in city traffic in the winter we recommend that you have the engine oil changed at 2 500 km (1 500 mile) intervals. Should you only drive a few hundred miles a month under these conditions, it is advisable to have the oil changed every 6 to 8 weeks. At other times these additional changes are unnecessary and uneconomical.

In countries with arctic climates and temperatures below about  $-25^{\circ}\text{C}$  ( $-13^{\circ}\text{F}$ ) the engine oil should be changed every 1 250 km (750 miles).

**Transmission oil** of SAE 90 grade can generally be used all the year round. Only in countries with arctic climates is it necessary to use the thinner SAE 80 transmission oil.

**The battery** not only tends to drop in capacity as the temperature drops, it also has to work much harder in the cold weather. Quite apart from the higher current consumption when starting and using the lights more often, there are numerous other electrical items used mainly in the winter, such as heated rear windows and heater boosters. A really cold battery which may in any case not be fully charged has only a fraction of the capacity that a battery at normal temperature has and this is fatal when trying to start a cold engine. If the car is only driven short distances and in city traffic, the battery should be charged from an external source from time to time.

**The spark plugs** should not have excessively large gaps especially in the winter. The gap is normally 0.7 mm (.028") but when the weather is very cold the gap can be tempo-

rarily reduced to 0.4—0.5 mm (.016—.020") to facilitate starting.

**The chassis** is exposed to very arduous conditions particularly in the winter. The steadily increasing use of chemicals to de-ice the roads produces solutions which attack even the most durable paintwork after a time. The underside of the Volkswagen is sprayed with a wax-based compound to protect it from these influences. It is advisable to examine the protective film at the beginning of the winter and have it repaired by respraying so that the full protective effect is retained. Do not apply oily anti-corrosion compounds to the wax-coated surface.

**Door locks** can freeze up in winter if water gets into the lock when washing the vehicle so do not aim the water jet directly at the locks. It is a good idea to cover the keyholes up beforehand. A frozen lock can be opened by warming the key well before inserting it. An anti-freeze solution or glycerine should then be squirted into the lock cylinder as soon as possible.

**It is a good idea** to carry a shovel or a short-handled spade in the car to clear away snow if you get stuck. A small hand brush for sweeping snow off the vehicle and a plastic scraper for the windshield are also useful.

## A clean, smart car looks better

We have provided your vehicle with paintwork which is not only extremely durable and has a very high gloss but which also has a long service life. This has been achieved by special chemical treatment of the body metal and the use of a four layer synthetic resin paint technique. But even the finest paint requires a certain amount of care. This is easy to appreciate if you consider for a moment the influences to which the paint is exposed. Sunlight, rain, industrial fumes, soot, dirt and dust are constantly working on and attacking the paintwork.

In the winter all parts of the vehicle are subjected to even more severe climatic conditions and the effect of aggressive salt solutions. It is advisable to clean and wax the vehicle more frequently in this period. Every VW Dealership has stocks of car cleaning materials. These materials have been tested by us and found to give the best results. The order numbers of these materials are given on pages 25, 26 and 27.

**Wash** the new vehicle frequently with clear water particularly in the first two or three months as this will help to harden the paintwork. Use a soft sponge or hose brush for the body, a long handled brush for the wheels and plenty of water. Spray the body panels and wheels with a fine soft spray first to loosen the dirt, then start at the top and wash downwards. Rinse the sponge out frequently to avoid scratching the paint.

Later on, the vehicle should always be washed when it is dirty. The longer the dirt is left on the paint the greater is the risk of it damaging the glossy finish. The dirt particles can have a chemical effect on the paint surface or they can cause scratches if rubbed into the paint. If the dirt cannot be removed with clear water, a suitable shampoo can be added to the water. Afterwards, rinse all traces of the shampoo off well with clear water and then leather the vehicle dry to avoid water spots.

**Waxing** should be carried out for the first time after about 8 to 10 weeks. Waxing is a means of putting back into the paint certain substances which keep it flexible and are lost in the course of time due to weathering and washing particularly when you use a detergent. The wax coating seals the pores of the paint and makes it water-repellent.

The paint should be re-waxed when water remains in large patches on the surface and does not form beads and roll off. Regular waxing will ensure that the paint retains its original high gloss for a long time.

Another way of waxing the paint is to use a wash-and-wax solution. This is easier than waxing in the normal way. Just wash the vehicle first then put the wash-and-wax solution in a bucket of water and apply it to the paintwork. All that remains is to leather off the paint until it is dry. This type of wax will only protect the paint adequately if it is used every time the vehicle is washed and the interval between washes is not more than two or three weeks.

**Polishing** should only be done when the paint has lost its gloss due to weathering or lack of proper care and the gloss can no longer be restored by waxing in the normal way. After treatment with polish, wax the paint thoroughly to retain the gloss which has been obtained.

**Never wash, wax or polish the car in the sunshine.**

**Before waxing and polishing, the vehicle must be washed and dried thoroughly.**

**Tar spots** tend to penetrate into the paint in a very short time. They should be removed as soon as possible, preferably with a tar remover. Afterwards, the area concerned should be washed with a solution of shampoo and water and rinsed well to remove all traces of tar remover.

**Insects** tend to stick on the front of the vehicle and on the windshield in the summertime. These should also be washed off the paint as soon as possible. When really dried on, the insects can be removed with an insect remover. The paintwork should also be washed, rinsed and leathered off afterwards.

**Parking under trees.** Vehicles which are parked under certain trees in the summer are often found to be covered with sticky spots. These spots can be taken off easily with a shampoo if the treatment is not delayed too long. It is advisable to wax the paint afterwards.

**Chrome parts** should be treated with a chrome cleaner or polish. To give lasting protection in the winter, the chrome parts can be coated with one of the patent chrome protection compounds which form a hard film. The best way to apply these compounds is by spraying. The film can be removed by washing with kerosene, then washing with shampoo and rinsing to remove all traces.

**The windows** can be cleaned with a sponge and clear water. Always use a special clean leather to dry the windows. This leather must not be used on the paintwork in any circumstances as most paint cleaners and polishes contain ingredients which will cause unpleasant streaks to appear on the windshield when it rains, even if only the smallest trace is present. These streaks can only be removed with a good windshield cleaner. Do not forget the wiper blades.

**The windshield wiper blades** should be taken off from time to time and cleaned with a hard brush and methylated spirits or a strong detergent solution. During long dry periods particularly they tend to get clogged with tar splashes, oil and insects. New blades should be fitted once a year.

**The Convertible top** does not require any special care. It is important however, to clean the plastic material regularly. When very dirty, the top can be cleaned with a soap powder solution or one of the normal plastic cleaners. A hard brush will help to remove dirt from the grained surface of the material but care must be taken at the edges to avoid scratching the paint with the bristles. After washing the top, the complete vehicle must be rinsed thoroughly with clear water.

Spots in the top material must never be removed with paint thinner, chlorine-based spot removers or similar solutions as this

will damage the material. Stubborn spots can be removed by wiping with a cloth moistened with white spirit (benzine) and then rinsing well with a lukewarm soap powder solution. The pivot points of the top linkage should be cleaned occasionally and a few drops of oil applied. Afterwards the joints should be wiped dry to ensure that oil does not drip on to the top material.

Noises caused by friction between the windows of the Convertible and the rubber weatherstrips can be eliminated by rubbing in some talcum powder or glycerine.

## Car care materials for the Volkswagen

	Material	Package and quantity	VW Part No.	Properties	How to use
Vehicle washing	Shampoo	Tin 150 cc	000 096 111	Washes effortlessly and thoroughly. Does not harm paint.	
	Shampoo	Tin 250 cc	000 096 112		
	Sponge	17 x 11 x 5.5 cm	000 096 151	—	
Paint waxing	Wax	Tin 250 cc	000 096 011	Protects paint from weather. Keeps it flexible and durable.	
	Wax	Tin 1000 cc	000 096 012		
	Wash/wax	Tin 150 cc	000 096 121	Washes and waxes in one operation. Protects paint from weather for a limited period.	
	Wash/wax	Tin 250 cc	000 096 122		
Paint polishing	Paint care	Tube 210 grams	000 096 021	Cleans, polishes and protects paint and brings gloss back again.	
	Paint polish	Tin 250 cc	000 096 001	Freshens up paint which has lost gloss.	
	Paint polish	Tin 1000 cc	000 096 002		
	Polishing cotton	Bag 200 grams	000 096 161	—	
Removal of tar spots from paint and chrome	Tar remover	Tin 150 cc	000 096 051	Softens and removes tar and asphalt spots.	
	Tar remover	Tin 250 cc	000 096 052		

	Material	Package and quantity	VW Part No.	Properties	How to use
Removal of insects from paint and chrome	Insect remover	Tube 80 grams	000 096 081	Removes insects from paint and glass	Dampen area to be cleaned, apply insect remover by moistening cotton, let it work for a short time and rub with cotton. Do not let it dry. Rinse area well with clear water.
Care and cleaning of chrome parts	Chrome cleaner	Tube 80 grams	000 096 061	Cleans, polishes and protects chromed parts	Apply thinly to clean chrome surface and polish with soft cloth.
	Liquid film for chrome	Bottle 500 cc	000 096 063	Forms a durable, transparent film on the chrome	Apply evenly to dry chrome. Spray on where possible (with spray gun 000 096 064)
	Spray gun	—	000 096 064	—	Used to apply liquid chrome protective film. Can be used for spraying other liquids.
	Chrome grease	Tube 80 grams	000 096 067	Cleans and protects chrome parts	Apply thick or thin coat (according to time of year) with a soft cloth. Renew coating every time vehicle is washed.
Cleaning PVC Convertible top	Plastic cleaner	Tin 200 grams	R 3	Cleans and protects PVC material	Apply cleaner with a damp sponge and rub with a dry cloth.
Cleaning windshield	Window cleaner	Bottle 200 cc	000 096 105	<b>Added to water in washer</b> it removes stubborn dirt, silicone and grease from windshield. Can be used as <b>anti-freeze</b> to keep washer in action in winter. Can be used neat to remove ice from windshield	<b>As windshield cleaner:</b> in the summer, add about $\frac{1}{10}$ of contents of bottle or 1 sachet to water in washer.  <b>As anti-freeze:</b> At temperatures down to $-15^{\circ}$ C add entire contents of bottle to water in washer. When not so cold, reduce amount. The contents of one sachet give protection down to $-2^{\circ}$ C.
	Window cleaner	Sachet approx. 35 cc	000 096 101		



**The cloth upholstery** should be cleaned with a vacuum cleaner or a fairly hard brush. Spots can usually be removed with a lukewarm soap solution. Grease and oil spots can be treated with spot remover. Do not pour the liquid on to the material as this will cause marks. Dampen a clean, plain cloth with the cleaner and remove the spot by rubbing with a circular movement and working inwards.

**The leatherette** parts of the headlining, side trim panels and seats can be cleaned best with a soft cloth or brush. When very dirty, use a lukewarm soap solution or a dry foam cleaner. If the seat upper surfaces and front of backrests are covered with leatherette as well, only use a dry foam cleaner because the material used for these parts is air-permeable and liquid cleaners would penetrate into the textile backing straightaway.

Grease or paint spots should be wiped off before they dry when possible. Once dry, they can be removed by rubbing carefully with a cloth moistened with benzine or methylated spirits. Shoe polish marks can be removed with turpentine but be careful because this will damage the dust repellent surface of the leatherette if allowed to work on it too long. Do not use trichlorethylene or paint thinner for deaning purposes. After cleaning, rub the material dry with a soft cloth. So-called preservatives are not suitable for leatherette because they do not soak into the material and merely collect dust and make clothing dirty.

**Airing the body.** If the vehicle is left in the garage for long periods, the garage and car doors must be opened from time to time to prevent the formation of mould and damp stains inside the vehicle.

**The front seats.** If the front seats get hard to slide, the runners must be greased lightly at top and bottom after being cleaned with a cloth. To remove the seats, disconnect the cable on the inside of the seat and push the seat forward out of the runners.

**Door and window weatherstrips** must be undamaged and supple to ensure that they seal properly. To retain the original flexibility of the rubber, coat the weatherstrips with talcum powder occasionally.



**The tires.** In addition to checking pressures regularly and driving carefully, the following points should be remembered in connection with tires:

- 1 — Check tires for damage occasionally and remove foreign bodies.
- 2 — Keep oil and gasoline away from the tires.
- 3 — Try not to expose tires to strong sunshine for long periods.
- 4 — Replace missing valve dust caps as soon as possible.

Tires should be replaced when the tread depth is only 1 mm all round and on full tread width because this is the absolute limit for safe usage. We advise you however not to let the tires wear down to this extent as tires with treads in this condition cannot grip the road surface properly when driving at high speeds on wet roads. If you notice that the tires are wearing unevenly, get advice from your VW workshop.

For smooth running at high speeds and long tire life it is essential that the wheels are balanced statically and dynamically. As the wheels can get out of balance after being in use for some time due to natural tire wear, the wheels should be balanced again every 10 000 km (6000 miles). Furthermore, a wheel should always be balanced again when a tire has been repaired. This also applies to balanced wheels when a tire has lost pressure due to a faulty valve.

## Just in case . . .

you have to deal with a small defect or a breakdown yourself one of these days we have included some information on the next few pages which should help you.

All other repairs should always be carried out by one of our service stations. The service organization of the VW factory offers you a wide-spread network of authorized workshops staffed by skilled mechanics and equipped with all the special tools and appliances required. Whenever you see the familiar VW sign on the roadside you can be sure of expert advice and quick efficient assistance.

### Wheel changing

Apply the hand brake.

Remove wheel cap with puller and jack bar by hooking the puller into the holes in the edge of the cap and levering against the wheel rim with the jack bar.

Loosen all wheel bolts about one turn with socket wrench and bar.

Insert jack into square hole under body and push the jack tube down until it touches the ground.



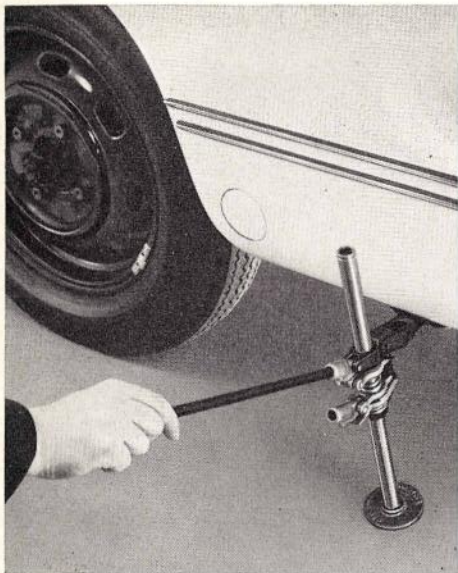

Place bar in upper link of jack and raise vehicle by moving bar up and down.

Unscrew wheel bolts and take wheel off.

Place spare wheel in position and raise or lower vehicle as necessary until the holes in the wheel are roughly in line with the threaded holes.



Insert one bolt and tighten it until the wheel can be swung round to align the other holes with the threaded holes.

Insert remaining bolts.

Tighten bolts until the wheel, centered by the spherical shape of the bolt heads, contacts with the threaded holes.

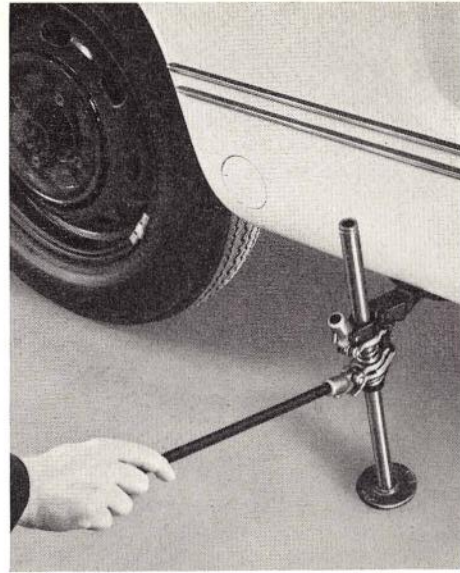

Place bar in lower link and lower the vehicle by moving bar up and down.

Tighten the wheel bolts evenly and diagonally.

Place trim ring in rim and install wheel caps by giving them a smart blow with the hand.

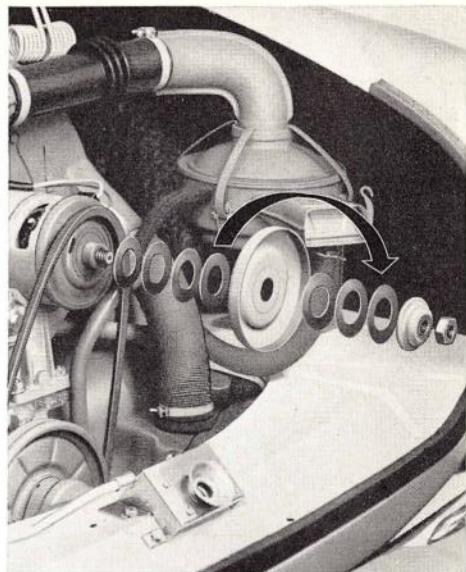
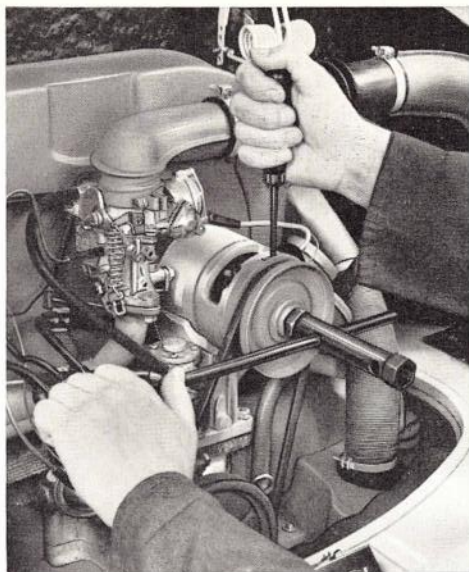

### Adjusting or replacing the fan belt

The fan belt tension is correct when the belt can be pressed inwards about 1.5 cm (.6") at the center. The belt must not be too tight or too slack. New belts may stretch slightly at first so they should be checked after about 500 km (300 miles) and the tension corrected if necessary. Even though the belt normally has a long service life, it is advisable to carry a spare on the vehicle.

To adjust the belt, remove the rear part of the pulley on the generator. When loosening and tightening the nut, place a screwdriver in the slot in the front half of pulley and support the screwdriver against the upper screw in the generator housing. To fit a new belt, the cover plate for the crankshaft pulley must also be removed after taking out the three screws.

The belt is tensioned by varying the number of washers between the pulley halves. Taking washers out increases the tension, putting them in decreases it.

### Cleaning fuel pump filter

Pull suction line off pump and seal it.

Remove plug and take filter out.

Wash filter in clean benzine and blow it out. When installing the filter, ensure that the washer for the plug is located properly.



### Removing and installing spark plugs

Pull connector off and screw plug out with socket wrench and bar.

Dirty plugs should be cleaned with a sand blaster but in an emergency the carbon can be removed with a chip of wood. Please do not use a wire brush. The plugs should also be clean and dry on the outside as well, in order to avoid shorting and tracking. The gap can be set by bending the ground electrode. The gap should normally be 0.7 mm (.028") but it can be reduced temporarily to 0.4—0.5 mm (.016—.020") when the weather is very cold, to facilitate starting.

Take care not to crossthread the plugs when inserting them and tighten them firmly but do not overtighten.

New plugs should be fitted every 20 000 km (12 000 miles).

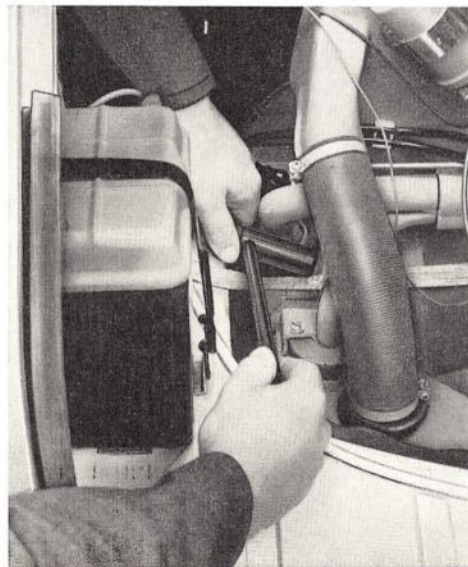

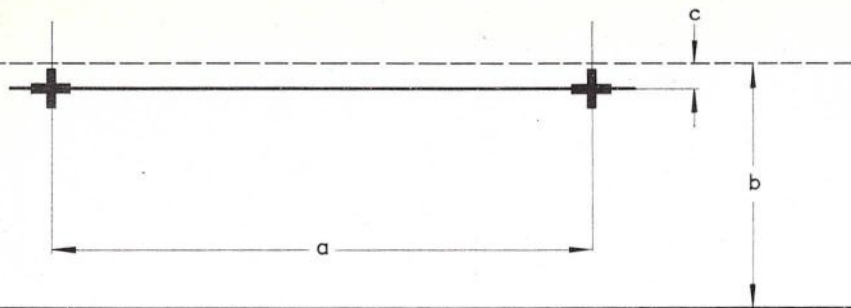

a — 1240 mm (48.8")  
 b — Height of headlight center from ground  
 c — 50 mm (2") at a distance of 5 m from the screen

## Aiming the headlights

### 1. Headlights with separate reflector and bulb

If a headlight aiming device is not available, proceed as follows:

Position the vehicle on a level surface 5 m (16 ft. 5 ins.) away from a vertical wall. The tire pressures must be correct and the rear seat loaded with one person or a weight of 70 kg (154 lbs.).

Draw two crosses with setting lines on the wall to the measurements above. The longitudinal center line of the vehicle must be aligned exactly with the center between the two crosses and at right angles to the wall. Aim the headlights individually by turning the two screws in the headlight rim with the beams dimmed. Cover up the second headlight.

A — Lateral aim  
 B — Vertical aim

The headlights are correctly aimed when the light-dark border line is horizontal on the adjusting line to the left of the cross and the angle in the light-dark border line is exactly on the cross.

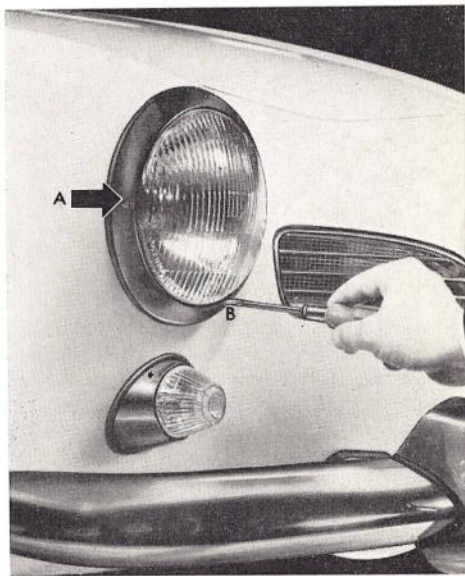

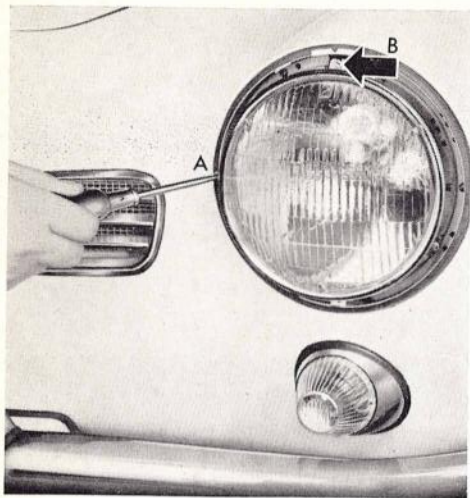

## 2. Sealed-Beam headlights

Position the vehicle on a level surface 7.6 m. (25 ft.) away from a vertical wall. The drivers seat must be loaded with one person or a weight of 70 kg. (154 lbs.).

Draw three setting lines on the wall to the measurements above. The longitudinal center line of the vehicle must be aligned with the center between the two vertical lines and at right angles to the wall.

Aim the headlights individually by turning the two slotted screws in the head lamp rim with low beams switched on. Cover up the second headlight.

The headlights are correctly aimed when the

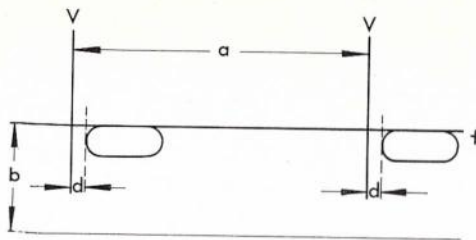

a — Distance between headlights (48.8")  
 b — Height of headlight center from floor  
 d — 2"

top edge of the high intensity zone is on the horizontal line H and the left edge is 2" to the right of the vertical line V.

A — Lateral aim  
 B — Vertical aim

## Bulb replacement

### Sealed-Beam units

Loosen screw in the center below the headlight and take the trim ring off.

Remove three screws in Sealed-Beam retaining ring and take ring off.

Take Sealed-Beam unit out of support ring and pull cable connector off.

When installing new Sealed-Beam unit, ensure that the three glass lugs engage properly in the support ring.

Check headlight settings.



## Headlight bulb

Remove screw in center below headlamp and take trim ring off.

Remove the screw in the center of the rim at the bottom and take lamp insert out.

Pull connector off bulb base.

Turn cap to left and take it off.

Install new bulb.

The lug on the bulb holder must engage in the notch provided in the reflector. Do not touch bulb glass with bare fingers.

Fit the cap so that the contact strip is resting on the base of the parking light bulb.

Check the headlight setting.



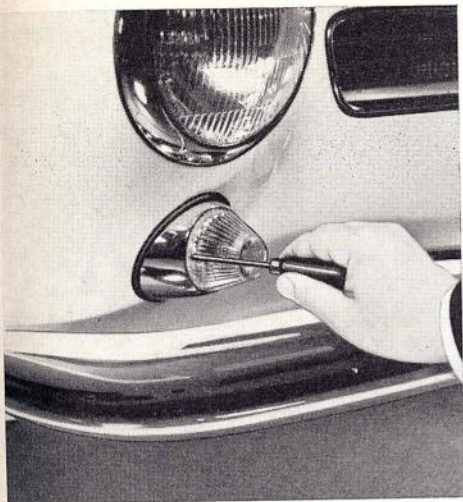

### Front turn signal bulb

Remove Phillips screw.

Take housing and lens off.

Press bulb into holder lightly, turn and take out.

Install new bulb.

When fitting housing, ensure that gasket is located properly.



### Rear turn signal, stop and tail light bulbs

Unscrew two Phillips screws so far that the lens can be taken off.

Bulb positions:

Top	— turn signal
Center	— stop
Bottom	— tail

Press bulb lightly into holder, turn and take out.

Install new bulb.

When fitting lens, ensure that gasket is located properly. Tighten lens securing screws evenly but do not overtighten.

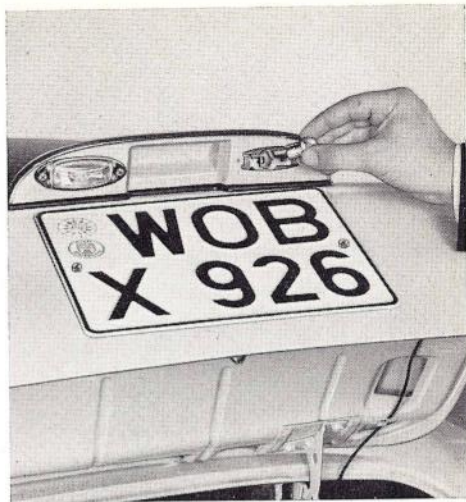

### License plate light bulb

Open rear hood.

Remove screws on each side of lens and take off lens with bulb holder.

Press bulb lightly into holder, turn and take out.

Install new bulb.

When installing, ensure that the gasket fits properly.

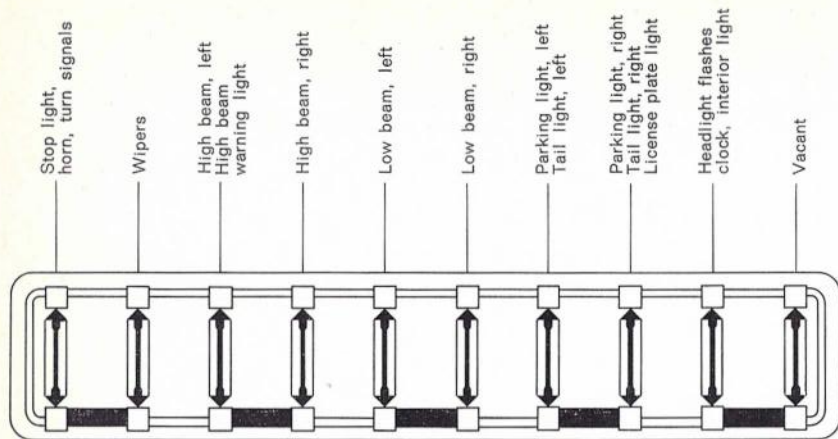

## Replacing fuses

The fuse box is located under the instrument panel near the steering column. The transparent lid on the fuse box has symbols embossed on it showing the various circuits. When a fuse blows it is not sufficient to merely replace it with a new fuse. The cause of the short circuit or overload must be established. On no account should fuses be patched up with tin foil or wire as this can cause serious damage elsewhere in the electrical system. It is advisable to always carry a few spare 8 Ampere fuses on the vehicle.

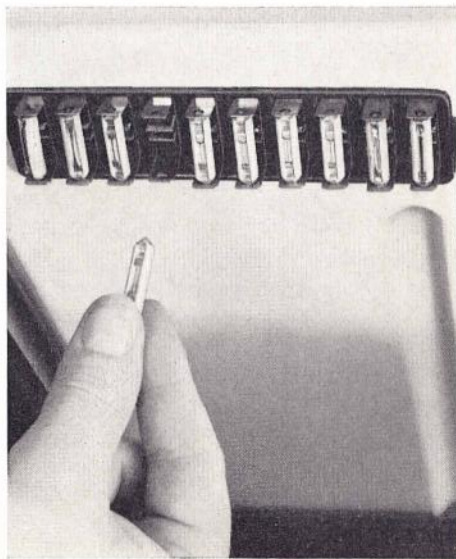

## Checking battery

The ability of the engine to start readily depends to a great extent on the condition of the battery. For this reason, the battery should be checked regularly and given a certain amount of attention.

To inspect the battery, lift the rear seat and take the cover off after releasing the securing strap.

Batteries with casings of light colored plastic do not have securing straps. They are secured to the floor plates with two small brackets. The cover is just pressed on.

To check the acid level, remove the plugs. The acid should always be just over the tops of the plates. The acid level should be in accordance with the mark. If the level is too low it must be topped up with distilled water.

The acid level drops when the battery is charged due to the dissociation of the water used to dilute the acid and, to a lesser extent, to evaporation. How often the battery has to be topped up depends mainly on operating conditions and indirectly on the time of year. When a vehicle is often driven long distances in the daytime with hardly any current being used, the battery will have to be topped up with distilled water much more often than in the case of a vehicle which is operating under different conditions. As a general rule, the battery acid level must be checked more often in the summer than in the winter. VW drivers in hot countries who do a lot of driving are advised to check the battery at least every week.

Do not put in more water than is necessary because if the level is too high the acid will overflow when the battery is being charged and cause damage.

The terminals and connections should be kept clean and greased with battery terminal grease. Ensure that the ground connection to the body is free of corrosion and tight.

If you lay your vehicle up for a prolonged period, it is advisable to take the battery to a workshop. A battery which is not in constant use will discharge itself in time and this can cause permanent damage to the plates if the battery is not checked about every four weeks and charged as necessary.



## Towing

Just in case you wish to attach a towrope to your vehicle one day, please note that the bumpers are not suitable for this purpose. If you do not expect the towing effort to be excessive, the rope can be attached at the rear to a lower shock absorber bracket. Otherwise we advise you to use the cross tube which houses the torsion bar for the rear suspension. Neither of these points are very easy to reach but they do at least ensure that your desire to help does not result in damage to your vehicle.

At the front, the rope should be attached to the lower axle tube as near to the frame head as possible.

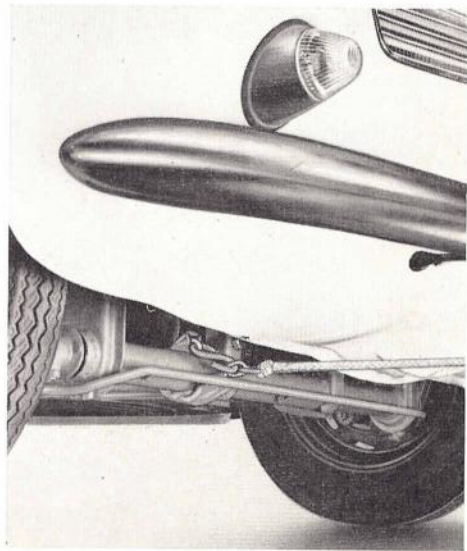
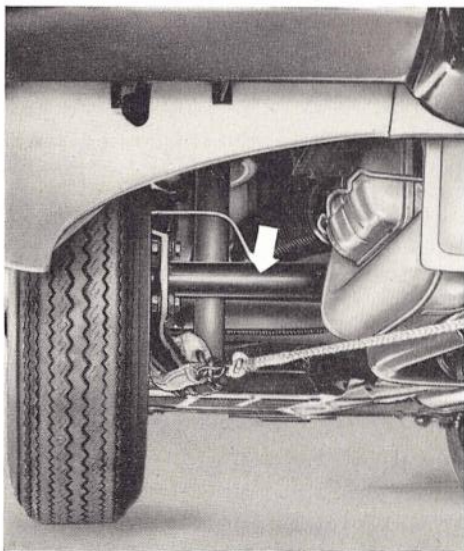

your Volkswagen that individual touch.

## Fit approved Volkswagen accessories.

Approved Volkswagen accessories are not just any old accessories. They have either been designed specially for the Volkswagen or selected from the vast range of accessories available and tested for use on the Volkswagen in the Volkswagen factory. The trademark "Approved Accessories" is your guarantee for material quality, good workmanship and reliability.

Approved VW accessories are supplied by your VW Dealer who will also fit them for you if necessary. You can fit lots of the accessories yourself.

<b>VOLKSWAGEN</b>	<b>Approved Accessories</b>
	<b>Accessoires Agréés</b>
	<b>Accessori Approvati</b>
	<b>Accesorios Aprobados</b>
<b>Erprobtes</b>	<b>Utprovade Tillbehör</b>
<b>Zubehör</b>	<b>Acessórios Aprovados</b>
	<b>Beproeefde Accessoires</b>

## Proper lubrication

means regular and careful lubrication. The lubrication chart on page 54 shows you at which intervals the various points require your attention.

### Engine

Regular oil changes are necessary even if the very best brand of HD oil is used because dirty oil in the engine means increased wear and reduces service life.

The oil is drained, when warm, by removing the plug in the oil strainer cover plate. Flushing is not necessary but the strainer must be removed and cleaned at every oil change. The gaskets and the copper washers under the cap nuts must always be renewed. The engine is then filled with 2.5 liters of HD oil (5.3 US pints/4.4 Imp pints).

Due to the detergent properties of the HD oil, the fresh oil will look very dark after the vehicle has been running for only a short time. This need not worry you and under normal operating conditions there is no reason whatever to change the oil at shorter intervals than every 5 000 km (3 000 miles). We only recommend more frequent oil changes — every 2 500 km / 1 500 miles — in the winter if you drive mainly short distances and in city traffic. If you only drive a few hundred miles a month under these conditions it is advisable to have the oil changed every 6 to 8 weeks. In countries with arctic climates where average temperatures are about  $-25^{\circ}\text{C}$  the oil should be changed every 1 250 km (750 miles).

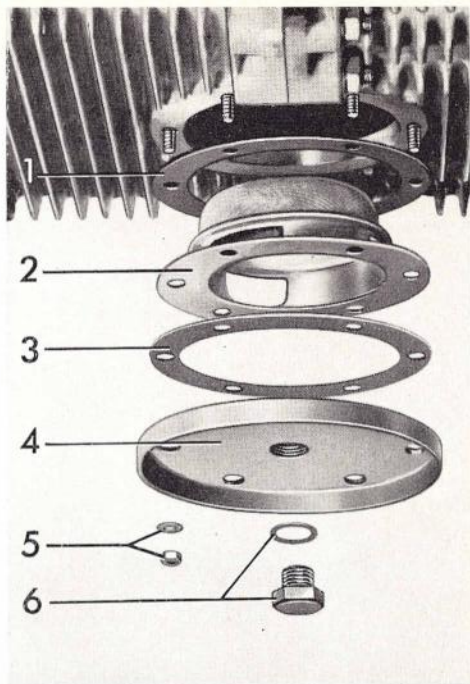
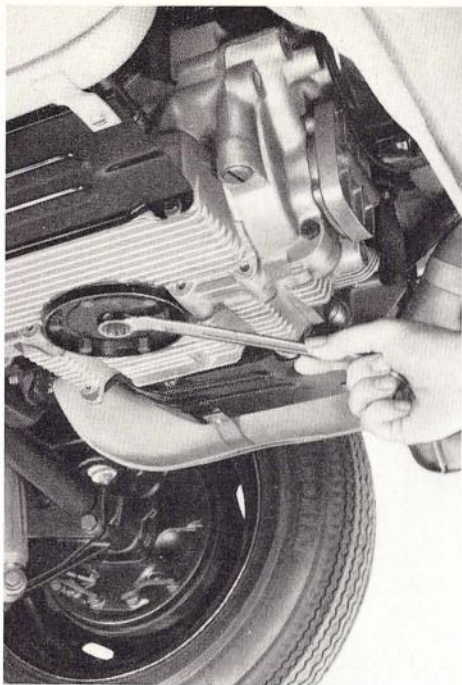

- 1 — Gasket
- 2 — Strainer
- 3 — Gasket
- 4 — Strainer cover
- 5 — Cap nuts and washers
- 6 — Drain plug and washer

## Some more information about oil

When changing and topping up the oil, try to always use the same brand of HD oil for gasoline engines. The quality of modern oils produced by reputable firms is so good that the choice of brand is left entirely to you. The VW engine makes no demands in respect of oil quality which cannot be fulfilled by every well known and popular brand. It is best to select "your" oil at the first 500 km oil change and stick to this brand on all occasions. Should you have any doubts at all, your VW Dealer will be pleased to advise you.

The classification of oil into various viscosity grades is shown by the designations SAE 30, SAE 20 W/20 and so on. The viscosity of a lubricant indicates its resistance to flow at a given temperature. The VW engine only requires two different viscosity grades which are used, according to season of year, as follows:

SAE 30 in warm seasons and all the year in countries with hot climates

SAE 20 W/20 In the winter,

or

SAE 10 W\* In areas where the average temperature is below  $-15^{\circ}\text{C}$  ( $5^{\circ}\text{F}$ )

SAE 5 W\* In countries with arctic climates and temperatures below  $-25^{\circ}\text{C}$  ( $-13^{\circ}\text{F}$ )

\* Avoid driving at high speeds for long periods if using SAE 10 W oil and the outside temperature is above  $0^{\circ}\text{C}$  or if using SAE 5 W oil when the temperature is above  $-15^{\circ}\text{C}$ .

All SAE grades cover a temperature range of about  $35^{\circ}\text{C}$  and the ranges of two neighbouring grades overlap by at least  $20^{\circ}\text{C}$ . Brief variations in temperature between seasons can therefore be disregarded. For the same reason it is also quite in order to mix oils of different viscosities when oil has to be added between oil changes and the viscosity of the oil in the engine no longer corresponds to the actual temperature. This is subject of course to the stipulation that the same brand of oil must be used.

In some countries, oils are classified according to the API system (American Petroleum Institute). Under this system, HD oils suitable for the VW engine are designated "For Service MS".

No additives of any sort should be mixed with HD oil.

## Temperature ranges of SAE grades

General use

Cold conditions only

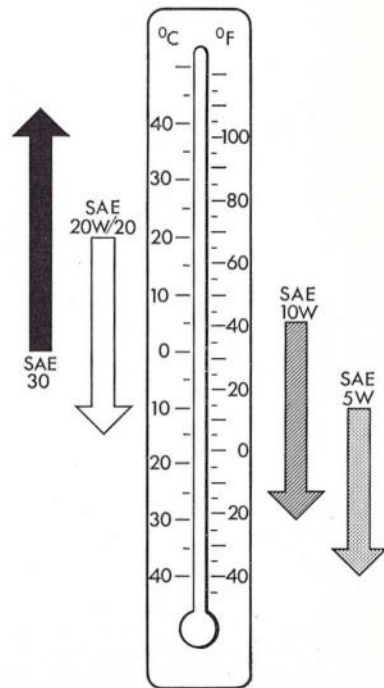

## Transmission

Transmission and differential are combined in one housing and both lubricated with the same **Hypoid oil**. The oil should be up to the edge of the filler hole.

At oil changes, the old oil should be drained when warm. The two magnetic oil drain plugs

must be cleaned carefully and 2.5 liters of good quality SAE 90 hypoid oil put in. In countries with arctic climates the thinner SAE 80 oil should be used all the year.

The oil sometimes runs into the transmission housing very slowly. If one attempts to put the oil in too quickly it may overflow and give the impression that the housing is already full although actually only about 1—1.5 liters have been put in. It is essential to the service life and silent running of the rear axle that the correct amount of oil is used in the transmission.

**Additives should not be put into a hypoid oil.**

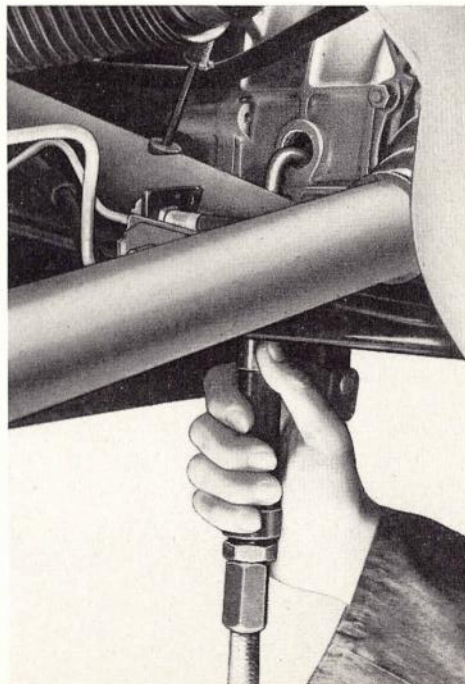
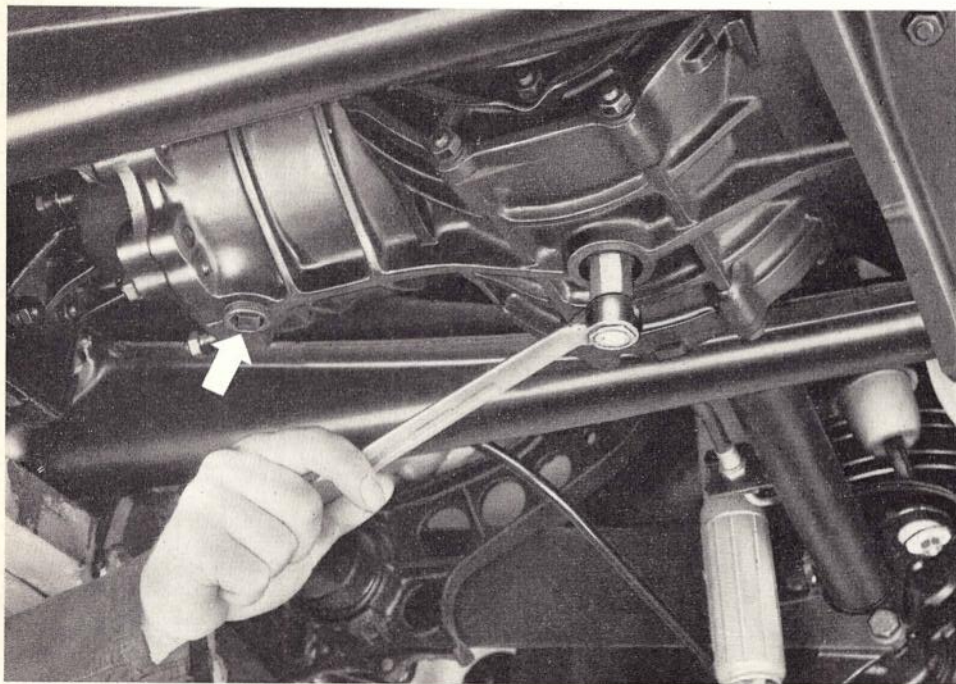



## Front axle

The front axle can only be lubricated properly when the axle is free of load, that is with the front end lifted.

There are four nipples on the axle tubes which must be lubricated with a lithium-based **multi-purpose grease**. The nipples and the grease gun nozzle should be cleaned carefully before greasing commences. Place gun on nipples and inject grease until fresh grease starts to come out at the torsion arm sealing rings.

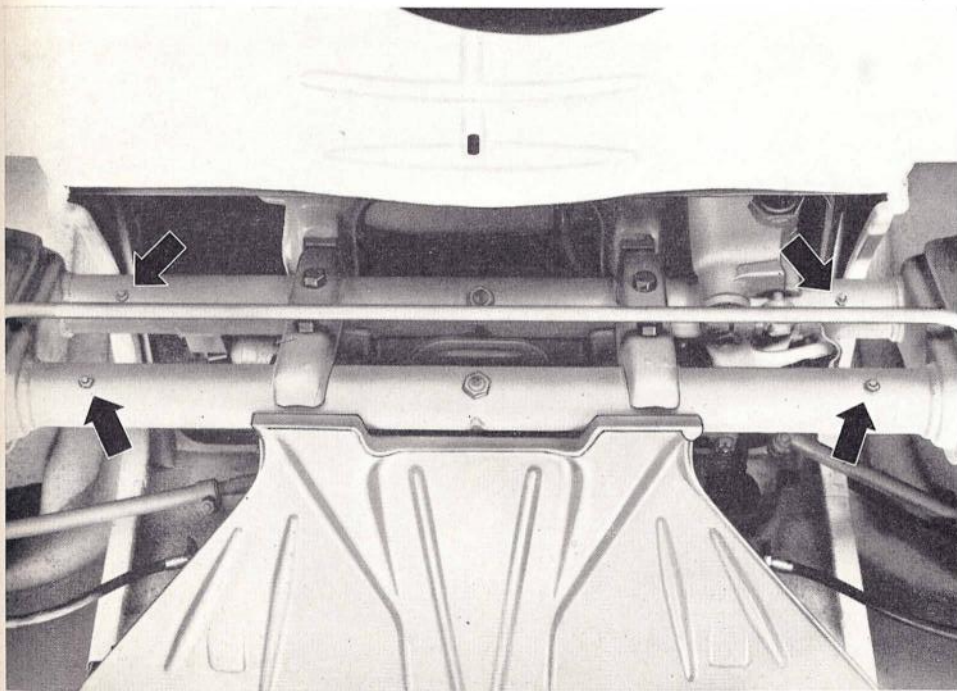

Grease and oil must not be left on tires and brake hoses for long periods. Even small traces should be wiped off immediately.

If the vehicle is driven less than 10 000 kms per year, the front axle must be lubricated once a year.

## Air cleaner

A dirty cleaner element not only reduces the engine output, it can also cause premature engine wear. If local conditions are such that the vehicle is often driven on very dusty roads, the cleaner must be checked frequently, even daily if necessary.

All the dust present in the air drawn in by the engine is retained by the filter element in the upper part of the air cleaner and washed out when the vehicle is in motion by the oil in the lower part. In time, this causes a layer of sludge to form at the bottom of the lower part. When there is only 4—5 mm of oil above the sludge layer, the lower part must be cleaned and filled with fresh oil. The cleaner must be removed to do this:

Pull crankcase breather hose off air cleaner.

Pull pre-heater hose off air cleaner intake elbow.

Release four clips and take intake pipe off top part of cleaner.

Take top part out. The top part must not be laid down with the filter element upwards.

Release two clips and take bottom part of cleaner out.

Clean bottom part carefully and fill to mark with fresh engine oil.

SAE 30 oil should be used all the year except in countries with arctic climates where SAE 10 oil should be used all the year.

The top part does not normally need cleaning. If the filter element has become so dirty due to delayed cleaning of the bottom part or oil shortage that the air inlet holes on the underside are partly blocked, the encrusted dirt should be scraped off with a piece of wood.

Check that the warm air flap in the intake pipe moves freely. At temperatures above  $+10^{\circ}\text{C}$  this flap should be fixed in position but at temperatures below  $+10^{\circ}\text{C}$  it should be free to move and regulate the flow of warm air according to the speed of the engine.

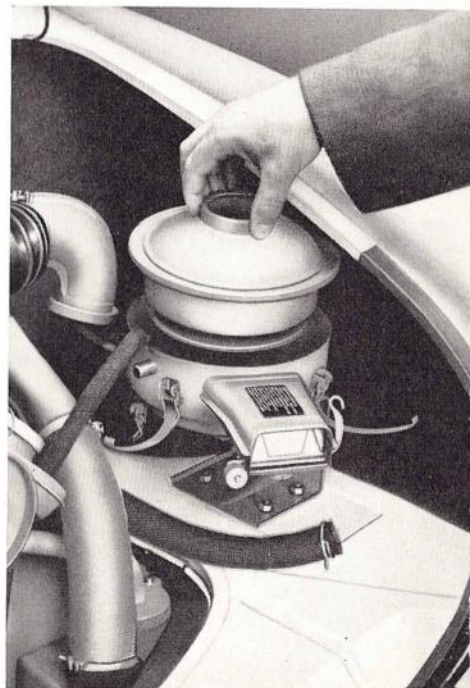

### doors and hoods

Door hinges do not require any lubrication. The lock cylinder is treated with graphite as necessary. The key can be dipped into the graphite and then turned in the lock a few times. The friction surfaces of the striker plates should be greased lightly as and when required.

Hood hinges should be oiled and the hood locks greased lightly.



## Technical data

### Engine

Four cylinder, four stroke, horizontally opposed in rear.

Thermostat controlled air cooling by fan.

Pressure oil feed with gear-type pump.

Oil cooler.

Mechanical fuel pump.

Downdraft carburetor with accelerator pump and automatic choke.

Oil bath air cleaner with air pre-heater.

Bore . . . . .	. 83 mm (3.27 ins)
Stroke . . . . .	. 69 mm (2.72 ins)
Capacity . . . . .	. 1493 cc (q 1.10 cu. ins)
Compression ratio . . . . .	. 7.5 : 1
Maximum output DIN . . . . .	. 44 bhp at 4000 rpm
SAE . . . . .	. 53 bhp at 4200 rpm
Maximum torque DIN . . . . .	. 10.2 mkg at 2000 rpm
SAE . . . . .	. 78.1 ft.lb. at 2600 rpm
Average piston speed . . . . .	. 9.2 m/s (1811 ft/min) at 4000 rpm
Valve clearance with engine cold . . . . .	. Inlet and exhaust 0.10 mm (.004")
Fuel consumption <sup>1)</sup> . . . . .	. approx. 8.5 liters per 100 km
	. 27.5 miles per US gallon
	. 33 miles per Imp. gallon
Fuel rating . . . . .	. 91 Octane (Res. F 1)
Oil consumption . . . . .	. 0.5—1.4 liters per 1000 km
	. 1.7—4.8 US pints per 1000 miles
	. 1.4—4.0 Imp. pints per 1000 miles

<sup>1)</sup> Measured consumption plus 10%, with half load at a steady  $\frac{3}{4}$  of maximum speed on level road.

### Power transmission

Single plate, dry clutch

Balk synchronized four-speed gearbox and bevel gear differential in one housing

Swing axles

Gear ratios: 1st gear 3.80 : 1, 2nd gear 2.06 : 1, 3rd gear 1.26 : 1, 4th gear 0.89 : 1, reverse gear 3.88 : 1

Differential ratio: 4.125 : 1

Clutch pedal free play: 10—20 mm (.4—.8")

gear  
 gear  
 l gear  
 ve shaft, front  
 verse gear  
 ve shaft, rear  
 itch release bearing  
 nsmission shift lever  
 gear  
 drain plugs  
 ve pinion  
 ferential side gear  
 ferential housing

14 — Differential pinion  
 15 — Flywheel  
 16 — Crankshaft  
 17 — Fan  
 18 — Carburetor  
 19 — Generator  
 20 — Cylinder head  
 21 — Piston  
 22 — Ignition coil  
 23 — Distributor  
 24 — Oil cooler  
 25 — Fuel pump  
 26 — Oil filler and breather

27 — Spark plug  
 28 — Camshaft  
 29 — Oil strainer  
 30 — Camshaft drive gear  
 31 — Oil pump  
 32 — Valve  
 33 — Heat exchanger  
 34 — Cylinder  
 35 — Oil pressure relief valve  
 36 — Connecting rod  
 37 — Thermostat

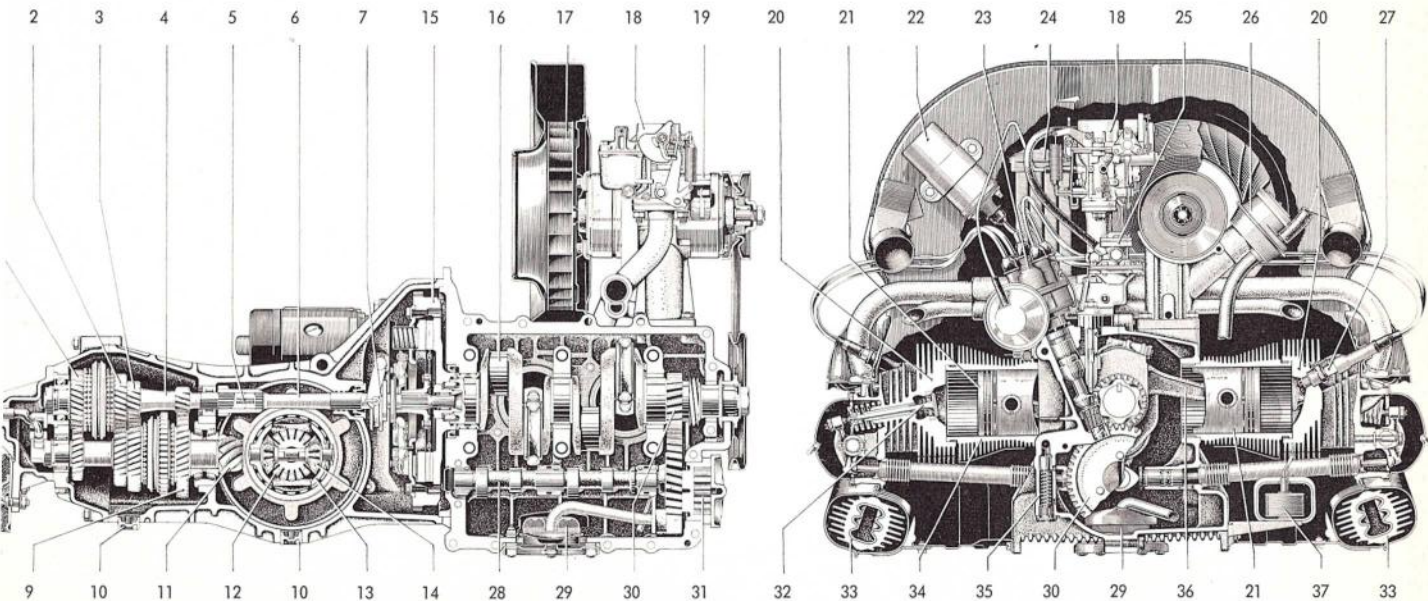

## Chassis

Platform frame with tunnel-shaped center member  
Front axle bolted to frame head, engine/transmission unit bolted to frame fork  
Independent suspension: double cranked trailing arms at front, swing axles with trailing arms at rear  
Torsion bar springing, double-acting telescopic shock absorbers, stabilizer at front, equalizer spring at rear  
Roller steering with maintenance free tie-rods and hydraulic steering damper  
Hydraulic, four-wheel, dual circuit, foot brakes, disc brakes at front  
Mechanical hand brake effective on rear wheels

Wheelbase	2400 mm (94.5 in)
Turning circle diameter	11.25 m (37 ft.)
Track at front	1305 mm (51.4 in)
Toe-in	2 to 4.5 mm (.08 to .18 in) unladen
Camber	30' ± 15' unladen
Track at rear	1350 mm (53.1 in)
Wheels	4 J x 15 Perforated wheel discs with drop center rims
Tires	5.60—15 4 PR tubeless
Tire pressures	With 1 or 2 occupants front 1.1 kg/cm <sup>2</sup> (16 psi), rear 1.7 kg/cm <sup>2</sup> (24 psi) fully loaded front 1.2 kg/cm <sup>2</sup> (17 psi), rear 1.8 kg/cm <sup>2</sup> (26 psi)

For long, high speed motorways, the pressures should be increased by 0.2 kg/cm<sup>2</sup> (3 psi) at front and rear.

## Electrical system

Voltage	6 Volts	12 Volts
Battery	66 Ah	36 Ah
Starter	0.5 hp	0.7 hp
Generator	max. 45 Ampere (early cut in)	max. 30 Ampere (early cut in)
Ignition distributor	with vacuum spark advance	
Firing order	1—4—3—2	
Basic ignition timing	7.5° before TDC (Rotor arm pointing to No. 1 cylinder mark on edge of distributor housing and left-hand mark on crankshaft pulley in line with crankcase joint.)	
Contact breaker gap	0.4 mm (.016 in)	

Spark plugs	Bosch W 175 T 1 Beru 175/14 Champion L 87 y	} or plugs with similar values from other manufacturers
Plug thread	14 mm	
Plug gap	0.7 mm (.028 in)	

### Dimensions and weights

Length	4140 mm (163.0 ins)
Width	1634 mm (64.3 ins)
Height	1330 mm (52.4 ins)
Ground clearance	152 mm (6.0 ins)
Unladen weight (ready for use)	840 kg (1851 lbs)
Permissible load	330 kg (727 lbs)
Gross vehicle weight	1170 kg (2579 lbs)
Permissible front axle load	490 kg (1080 lbs)
Permissible rear axle load	710 kg (1565 lbs)

### Capacities

Fuel tank	40 liters (10.6 US galls; 8.8 Imp galls)
Engine	2.5 liters (5.3 US pints; 4.4 Imp pints)
Rear axle and transmission	2.5 liters
Brake system	approx. 0.25 liter (.53 US pints; .44 Imp pints)
Oil bath air cleaner	approx. 0.30 liter (.7 US pints; .6 Imp pints)
Windshield washer	approx. 1 liter (2.1 US pints; 1.75 Imp pints)
	operating pressure 2.5 kg/cm <sup>2</sup> (35 psi)

### Performance

Maximum and cruising speed	132 kph (82 mph)
Acceleration time from 0—80 kph (0—50 mph)	approx. 13 seconds
Climbing ability	
1st gear	45.0 %
2nd gear	23.0 %
3rd gear	13.0 %
4th gear	8.0 %

# Bulb chart

V — Volt    W — Watt

Bulb for	6 Volt system		12 Volt system*	
	German designation	VW Part No.	German designation	VW Part No.
Headlamp . . . . .	A 6 V 45/40 W	N 17 705 1	A 12 V 45/40 W	N 17 705 3
Headlamp (Sealed-Beam) . .	—	111 941 161 A	—	111 941 261 A
Parking light (except Sealed-Beam) . . .	HL 6 V 4 W	N 17 717 1	HL 12 V 4 W	N 17 717 2
Parking light (Sealed-Beam) with front turn signal . . . .	S 6 V 18/5 W	N 17 737 1	SL 12 V 21/5 W	N 17 738 2
Stop light . . . . .	R 6 V 18 W	N 17 731 1	RL 12 V 21 W	N 17 732 2
License plate light . . . . .	G 6 V 5 W	N 17 718 1	G 12 V 5 W	N 17 718 2
Instrument and warning lights	T 6 V 1.2 W	N 17 722 1	T 12 V 2 W	N 17 722 2
Interior light . . . . .	HL 6 V 4 W	N 17 717 1	HL 12 V 4 W	N 17 717 2
Turn signal, front and rear .	R 6 V 18 W	N 17 731 1	RL 12 V 21 W	N 17 732 2
Tail light . . . . .	G 6 V 5 W	N 17 718 1	G 12 V 5 W	N 17 718 2
Back-up light (USA only) . .	—	—	12 V 25 W	N 17 733 2

\* Vehicles with 12 Volt systems are marked with a sticker on the hinge pillar



## In the vehicle documents

are, amongst other things, the model designation and the chassis and engine numbers. The police or Traffic Department attach much importance to these details.

### The Identification Plate

is behind the spare wheel underneath the front hood.

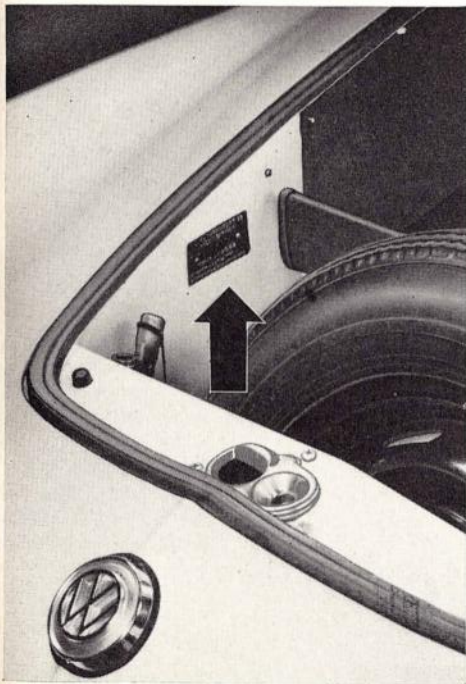

### The Chassis Number

is on the frame tunnel under the rear seat.

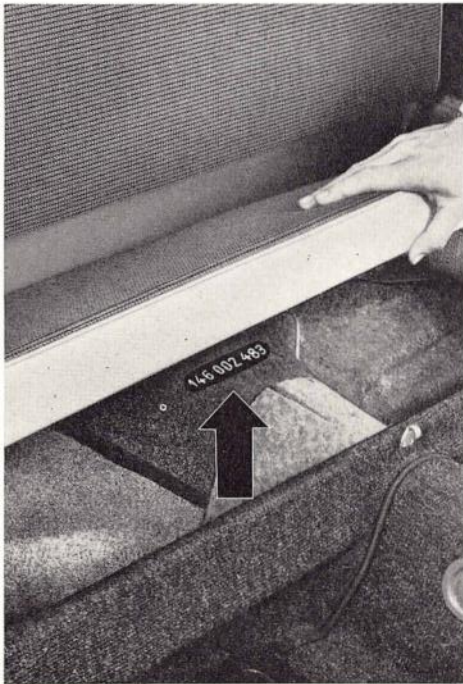

### The Engine Number

is on the generator support flange.

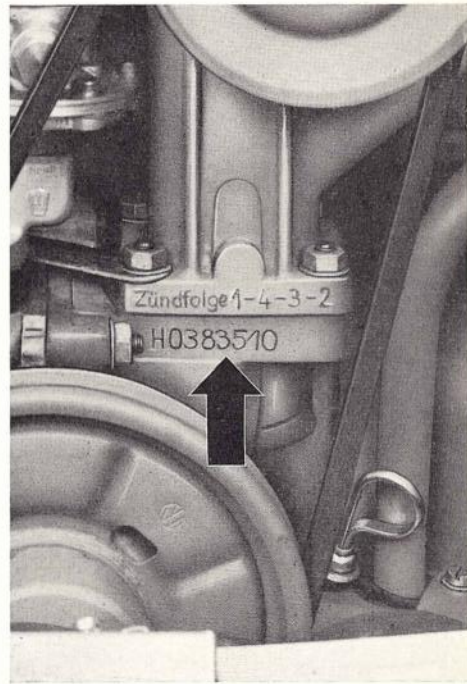

# Index

Accelerator pedal . . . . .	11	Climbing ability . . . . .	49	Front axle — lubrication . . . . .	43
— accelerating . . . . .	19	Clutch — design . . . . .	46	— technical data . . . . .	48
Accessories . . . . .	39	— pedal . . . . .	11	Front seats — adjustment . . . . .	6
Air cleaner — checking and cleaning	17/44	— pedal free-play . . . . .	46	Fuel consumption . . . . .	46
Ash tray . . . . .	9	Compression ratio of engine . . . . .	46	— delivery . . . . .	46
		Contact breaker gap . . . . .	48	— filter cleaning . . . . .	32
		Convertible . . . . .		— gauge . . . . .	8
		— opening and closing top . . . . .	16	Fuel tank — capacity . . . . .	15
		— care of top . . . . .	24	— reserve . . . . .	8
		— lubrication of top . . . . .	24	Fuse box . . . . .	36
		Cooling of engine . . . . .	46	Fuses — replacing . . . . .	36
Backrest lock . . . . .	6	Dimensions . . . . .	49	Gear lever . . . . .	11
Battery — maintenance . . . . .	37	Dimming . . . . .	9	Gear shifting . . . . .	19
— care in winter . . . . .	21	Dipstick . . . . .	17	Generator . . . . .	48
Body — airing . . . . .	27	Doors . . . . .	7	Ground clearance . . . . .	49
Brakes — application . . . . .	11/19	— locking knob . . . . .	7		
— care in winter . . . . .	20	— lubrication points . . . . .	45	Hand brake — description . . . . .	48
— checking . . . . .	17	— locks frozen . . . . .	21	Headlights — aiming . . . . .	33
— description . . . . .	48			— flasher . . . . .	9
Breaking-in . . . . .	19			— Sealed Beams . . . . .	34
Bulb chart . . . . .	50	Economy . . . . .	19	Heating . . . . .	11
Bulb replacement . . . . .		Engine — design . . . . .	46	Horn ring . . . . .	9
— tail light . . . . .	35	— number . . . . .	51	Hood lock — Convertible . . . . .	9
— license plate . . . . .	35	— oil strainer . . . . .	40	— knob . . . . .	9
— stop light . . . . .	35	— sectional view . . . . .	47		
— turn signal . . . . .	35	— technical data . . . . .	46	Identification plate . . . . .	51
— headlight . . . . .	34	Engine oil — type . . . . .	40	Ignition — setting . . . . .	48
— Sealed-Beam . . . . .	34	— specifications . . . . .	41	— distributor . . . . .	48
		Instrument lights . . . . .	9	Interior light . . . . .	10
		— changing in winter . . . . .	21		
		— changing and capacities . . . . .	4	Jack . . . . .	30
Carburetor type . . . . .	46	Firing order . . . . .	48		
Camber . . . . .	48	Foot brake — description . . . . .	48		
Care of — car . . . . .	22				
— chrome . . . . .	24				
— weatherstrips . . . . .	28				
Chassis — care in winter . . . . .	21				
— description . . . . .	48				
lubrication . . . . .	43				
— number . . . . .	51				



# The lubrication and maintenance charts

list all the operations which we specify for the lubrication and maintenance services. Having this work carried out regularly by an authorized VW Dealer is an essential part of the instructions regarding the operation of your Volkswagen. Please see paragraph 6 of our warranty conditions in this connection.

## Lubrication chart

Operation	W 1 At 500 km (300 miles)	WS 5 At 5000, 15000, 25000 km (3000, 9300, 15000 miles) and so on	W 10 At 10000, 20000, 30000 km (6000, 12000, 18000 miles) and so on
Engine: Change oil, clean strainer, check for leaks	x	x	x
Rear axle: Change oil, clean magnetic drain plugs, check for leaks	x		Only at 50000, 100000 km (30000, 60000 miles) and so on
Rear axle: Check oil level, top-up as necessary, check for leaks			x
Front axle: Lubricate			x
Door and hood locks: Lubricate		x	x
Carburetor linkage: Lubricate		x	x
Air cleaner: Check, clean lower part if necessary and put fresh oil in			x
Battery: Check voltage and acid level, add distilled water if necessary. Clean and grease terminals		x	x
Windshield washer: Fill	x	x	x

### Important

If your Volkswagen is driven less than 10 000 km (6 000 miles) a year, have the torsion arm bearings in the front axle greased once a year. The door and hood locks should be lubricated at least every 3 months.

## Maintenance chart

Operation	W 1 At 500 km (300 miles)	W 10 At 10000, 20000, 30000 km (6000, 12000, 18000 miles) and so on
Check security of rear axle shaft nuts and tighten if necessary	x	
Check V belt, tighten or replace if necessary	x	x
Clean fuel pump filter	x	x
Check contact breaker points, replace if necessary; lubricate distributor, adjust breaker gap and ignition timing	x	x
Adjust valve clearance and fit new cylinder head cover gaskets	x	x
Clean spark plugs, check and adjust plug gaps. Check compression.		x
Check control flap for carburetor preheating		x
Check rubber valve for crankcase ventilation, replace if necessary and check exhaust system for damage		x
Adjust clutch pedal free-play	x	x
Check dust seals on steering ball joints and tie-rod ends. Check security of tie-rods and tighten if necessary	x	x
Clean front wheel bearings, pack with grease and adjust (includes removal and installation of both brake discs)		W 50 Only at 50000, 100000 km (30000, 60000 miles) and so on
Check front wheel camber and toe-in	x	x
Steering gear: Check and adjust play between roller and worm		x
Correct tire pressures. Check security of wheel bolts and tighten if necessary	x	
Check tires for wear and damage, rectify inflation pressures		x
Check brake system for leakage and damage, check fluid level and top-up if necessary, adjust hand and foot brakes	x	x
Check thickness of brake linings		x
Check operation of electrical system, adjust headlight alignment	x	x
Road test: Check efficiency of foot and hand brakes, check and adjust idling and heating	x	x



**GENUINE VW PARTS** are the proper replacement parts for the Volkswagen. They guarantee accuracy, quality and reliability. Every part of the Volkswagen is available as a Genuine VW Part and all are naturally of the same high quality as the original parts on the vehicle when it leaves the factory. Genuine VW parts are covered by the same warranty conditions as brand new vehicles. The genuine parts are expertly installed in every VW workshop.



**Austauschdienst**  
**Exchange Service**  
**Service**  
**d'échange-standard**  
**Servizio rotazione**  
**Servicio de Canjeo**  
**Utbytessystem** **Serviço de Troca**  
**Ruil-System**

**VW EXCHANGE PARTS** are also replacement parts for your Volkswagen just like the Genuine VW Parts. These parts are covered by the same warranty conditions as Genuine VW parts and they are available in every VW workshop. But there is one difference: The price.

VW Exchange Parts are cheaper than Genuine VW Parts but exactly the same quality. The exchange parts are not new parts, but parts which have been reconditioned in the Volkswagen factory. That is why you have to hand in the old repairable part to get an exchange part.

Please consult your VW workshop on all questions concerning repairs. They will be pleased to advise you and your vehicle will be in good hands.

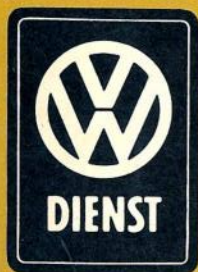

# Warranty of Volkswagenwerk Aktiengesellschaft for New Volkswagen Automobiles and Genuine Volkswagen Parts

This warranty applies to automotive vehicles of Volkswagenwerk Aktiengesellschaft (VW) of all models and types, as well as parts for such automotive vehicles (including exchange units), to the extent that such automotive vehicles and parts are supplied by VW (VW Products). This warranty covers parts manufactured by VW itself, as well as such parts which VW acquires from other manufacturers and either installs or supplies as parts.

1. Warranty claims can be made only through an authorized VW dealer or authorized VW repair shop. They must be made forthwith upon ascertainment of the defects. The repairs must be performed in the repair shop of an authorized VW dealer or in an authorized VW repair shop.

2. VW warrants VW Products to be free of defects in material and workmanship according to current industrial standards. The warranty becomes effective at the time of delivery of the VW Product by the authorized VW dealer, or the authorized VW repair shop, to the customer. The warranty expires six months thereafter or when the VW Product has been driven or used over a distance of six thousand miles, whichever event shall first occur.

4. This warranty is expressly in lieu of all other express or implied warranties, obligations or liabilities of VW and of the selling dealer, whether for direct or consequential damage or otherwise, including obligations for breach of express or implied conditions and including,

As to VW vehicles assembled outside of Germany, the warranty of VW is limited to those components which are supplied by VW.

3. The obligation under this warranty is limited, at the election of VW, to the replacement or repair of such parts as shall be acknowledged by VW to be defective in material or workmanship. At the request of VW, parts to be replaced must be exhibited or shipped from the office where the claim is made through the proper distributor or Exclusive Importer to VW or its designee. All parts which shall have been replaced shall become the property of VW.

No charge will be made to the customer with respect to the removal or installation of parts or with respect to freight incurred pursuant to this warranty.

but not by way of limitation, express or implied warranties of merchantability or fitness for any particular purpose.

5. There shall be no right of rescission or to a reduction of the purchase price unless VW should not be in a position to cure the defect. The warranty is fully discharged:

- If the VW Product has been interfered with by unauthorized persons in any manner not approved by VW; or
  - If parts have been installed the use of which has not been approved by VW; and if in the sole judgment of VW the damage is causally related to the interference in case (a) or to the installation of unapproved parts in case (b).
- The warranty will also be fully discharged if the customer has not complied with the instructions (Instruction Manual) of VW for the operation of the VW Product.

7. Normal wear and tear is excepted from the warranty. The same applies to damage brought about by negligent or improper handling, including, but not by way of limitation, damage due to storage or corrosion.

## Delivery Inspection

Date \_\_\_\_\_  
Miles \_\_\_\_\_

(Dealer Stamp)

## 300 miles W 1

Date \_\_\_\_\_  
Miles \_\_\_\_\_

(Dealer Stamp)

## Free Maintenance, Engine and Transmission Oil change

## 3 000 miles WS 5

Date \_\_\_\_\_  
Miles \_\_\_\_\_

(Dealer Stamp)

## Oil change

### Lubrication Service

1. Engine: Change oil, clean oil strainer.

2. Transmission: Change oil, clean magnetic drain plugs. Check for leaks.

3. Windshield washer: Fill.

### Station Wagons and Trucks

4. Reduction gears: Change oil.

5. Front end: Lubricate.

### Maintenance Service

1. Check security of rear axle shaft nuts, tighten if necessary.

2. Check V belt, tighten or replace if necessary.

3. Clean fuel pump filter.

4. Check contact points, lubricate distributor, adjust breaker gap and ignition timing.

5. Adjust valve clearance and fit new cylinder head cover gaskets.

6. Adjust clutch pedal free-play.

7. Check dust seals on ball joints and tie rod ends. Check security of tie rods, tighten if necessary.

8. Check front wheel camber and toe-in.

9. Correct tire pressures. Check tightness of wheel bolts, tighten if necessary.

10. Check brake system for damage and leaks, check brake fluid level, add if necessary.

11. Check operation of electrical system, aim headlights.

### The Service Adviser (Quality Control)

During road test:

Check efficiency of braking, steering, heating and ventilation systems. Check overall performance.

After road test:

Check cylinder head covers for leaks. Check and adjust idling.

Remarks: \_\_\_\_\_



<b>6 000 miles W 10</b> Date _____ Miles _____  <b>Maintenance and Oil change</b>  (Dealer Stamp)	<b>9 000 miles WS 5</b> Date _____ Miles _____  <b>Oil change</b>  (Dealer Stamp)	<b>12 000 miles W 10</b> Date _____ Miles _____  <b>Maintenance and Oil change</b>  (Dealer Stamp)	<b>15 000 miles W 10</b> Date _____ Miles _____  <b>Oil change</b>  (Dealer Stamp)	<b>18 000 miles W 10</b> Date _____ Miles _____  <b>Maintenance and Oil change</b>  (Dealer Stamp)	<b>21 000 miles WS 5</b> Date _____ Miles _____  <b>Oil change</b>  (Dealer Stamp)
<b>24 000 miles W 10</b> Date _____ Miles _____  <b>Maintenance and Oil change</b>  (Dealer Stamp)	<b>27 000 miles WS 5</b> Date _____ Miles _____  <b>Oil change</b>  (Dealer Stamp)	<b>30 000 miles W 10</b> Date _____ Miles _____  <b>Maintenance, Engine and Transmission Oil change</b>  (Dealer Stamp)	<b>30 000 miles W 50 Wheel bearing lube</b> Date _____ Miles _____    (Dealer Stamp)	<b>33 000 miles WS 5</b> Date _____ Miles _____  <b>Oil change</b>  (Dealer Stamp)	<b>36 000 miles W 10</b> Date _____ Miles _____  <b>Maintenance and Oil change</b>  (Dealer Stamp)
<b>39 000 miles WS 5</b> Date _____ Miles _____  <b>Oil change</b>  (Dealer Stamp)	<b>42 000 miles W 10</b> Date _____ Miles _____  <b>Maintenance and Oil change</b>  (Dealer Stamp)	<b>45 000 miles WS 5</b> Date _____ Miles _____  <b>Oil change</b>  (Dealer Stamp)	<b>48 000 miles W 10</b> Date _____ Miles _____  <b>Maintenance and Oil change</b>  (Dealer Stamp)	<b>51 000 miles WS 5</b> Date _____ Miles _____  <b>Oil change</b>  (Dealer Stamp)	<b>54 000 miles W 10</b> Date _____ Miles _____  <b>Maintenance and Oil change</b>  (Dealer Stamp)

<b>57 000 miles WS 5</b> Date _____ Miles _____ <b>Oil change</b> (Dealer Stamp) _____	<b>60 000 miles W 10</b> Date _____ Miles _____ <b>Maintenance, Engine and Transmission Oil change</b> (Dealer Stamp) _____	<b>60 000 miles W 50 Wheel bearing lube</b> Date _____ Miles _____	<b>63 000 miles WS 5</b> Date _____ Miles _____ <b>Oil change</b> (Dealer Stamp) _____	<b>66 000 miles W 10</b> Date _____ Miles _____ <b>Maintenance and Oil change</b> (Dealer Stamp) _____	<b>69 000 miles WS 5</b> Date _____ Miles _____ <b>Oil change</b> (Dealer Stamp) _____
<b>72 000 miles W 10</b> Date _____ Miles _____ <b>Maintenance and Oil change</b> (Dealer Stamp) _____	<b>75 000 miles WS 5</b> Date _____ Miles _____ <b>Oil change</b> (Dealer Stamp) _____	<b>78 000 miles W 10</b> Date _____ Miles _____ <b>Maintenance and Oil change</b> (Dealer Stamp) _____	<b>81 000 miles WS 5</b> Date _____ Miles _____ <b>Oil change</b> (Dealer Stamp) _____	<b>84 000 miles W 10</b> Date _____ Miles _____ <b>Maintenance and Oil change</b> (Dealer Stamp) _____	<b>87 000 miles WS 5</b> Date _____ Miles _____ <b>Oil change</b> (Dealer Stamp) _____
<b>90 000 miles W 10</b> Date _____ Miles _____ <b>Maintenance, Engine and Transmission Oil change</b> (Dealer Stamp) _____	<b>90 000 miles W 50 Wheel bearing lube</b> Date _____ Miles _____ <b>Oil change</b> (Dealer Stamp) _____	<b>93 000 miles WS 5</b> Date _____ Miles _____ <b>Oil change</b> (Dealer Stamp) _____	<b>96 000 miles W 10</b> Date _____ Miles _____ <b>Maintenance and Oil change</b> (Dealer Stamp) _____	<b>100 000 miles W 10</b> Date _____ Miles _____ <b>Maintenance, Engine and Transmission Oil change</b> (Dealer Stamp) _____	<b>100 000 miles W 50 Wheel bearing lube</b> Date _____ Miles _____ (Dealer Stamp) _____

© 1966 VOLKSWAGENWERK AKTIENGESELLSCHAFT All rights reserved. Reproduction or translation in part or in full is not permitted without our written consent. VOLKSWAGENWERK AKTIENGESELLSCHAFT  
Typ 1 und 2 · 556.167.23 · Printed in Germany · H. Osterwald, Hannover · 8. 66

## Delivery Inspection

Checklist for \_\_\_\_\_  
(Chassis number)

Check  
Mark

### BEFORE ROADTEST

**Engine**  
Oil level  
Fan belt tension  
Starting  
**Chassis**  
Cotter pins for rear axle shaft nuts  
Wheel bolts  
Tire pressures  
Brake fluid reservoir  
Brake lines and hoses  
Steering components  
Engine and transmission for leaks

### DURING ROADTEST

**Clutch**  
Clutch pedal free-play  
**Transmission**  
Gear shifting  
**Chassis**  
Foot and hand brake  
Steering, position of steering wheel  
Heating  
Fresh air ventilation  
**Electrical system and instruments**  
Warning lights  
Generator  
Oil pressure  
Turn signals  
High beam  
Emergency blinker  
Horn  
Windshield wipers and washer  
Speedometer  
Fuel gauge  
Clock  
Back-up lights

### AFTER ROADTEST

**Engine (warm)**  
Idling adjustment  
**Electrical system**  
Headlight dimmer switch  
Headlight adjustment  
Tail and stop lights  
License plate light  
Instrument light  
Interior light  
Turn signal and emergency blinker lights  
**Body**  
Paintwork  
Chromium-plated parts  
Upholstery, interior trim  
Operation of seat adjustment  
Windows and regulators  
Mirror  
Door and hood locks  
Door hinges  
Sliding roof  
Tools, jack  
Spare V belt

Remarks: \_\_\_\_\_  
Vehicle in perfect condition

\_\_\_\_\_  
(Signature of Service Adviser/Date)

# MAINTENANCE CARD

## The Importance of Preventive Maintenance

1. You naturally expect your Volkswagen to be reliable and economical and to last a long time, no matter how many miles you travel, how you drive or how bad the weather and roads are. This Maintenance Card in the Instruction Manual with its reminders for regular lubrications and maintenance services will help you achieve this.
2. The empty spaces will tell you when oil changes, lubrications and maintenance services are due. These maintenance services keep your Volkswagen in good running condition and so contribute to your safety and help retain your vehicle's value. The mileages printed in the spaces tell you at a glance when the next oil change, lubrication or maintenance service is due.
3. Just hand this Instruction Manual to an Authorized Volkswagen Dealer — he will do the rest. The details are subject to alternation without notice.
4. The first oil change and maintenance service at 300 miles and the oil change at 3000 miles are particularly important if your Volkswagen is to be properly broken in so that it can enjoy a long, trouble-free life. This Maintenance Card contains a punchcard for the free-of-charge maintenance service at 300 miles.
5. From 6000 miles onward, the combined lubrication and maintenance service should be performed every 6000 miles. Engine oil should be changed every 3000 miles. If your Volkswagen is driven less than 3000 miles in 3 months, have the oil changed every 3 months; if driven less than 6000 miles in 12 months, have the front end lubricated once a year.
6. Every Authorized Volkswagen Dealer at home or abroad guarantees to perform all the operations listed for maintenance and lubrication services in accordance with Volkswagen quality standards.

### Warranty Voucher

for the new VW automobile

Type: \_\_\_\_\_

Chassis No. \_\_\_\_\_

Engine No. \_\_\_\_\_

In accordance with the terms of warranty printed overleaf.



The warranty commences at the date the VW automobile is delivered to the original purchaser,

viz. on \_\_\_\_\_  
(To be filled in by selling VW Dealer)

and covers a period of 6 months or the period before the vehicle has been driven 6000 miles, whichever event shall first occur. Should any warranty claim arise, you are requested to submit this voucher to your VW Dealer.

VOLKSWAGENWERK AKTIENGESELLSCHAFT

*[Handwritten signature]*  
VW logo  
*[Handwritten signature]*

will be performed without charge, except for the cost of lubricants used.

When the punch card "Free Maintenance Service — 300 miles" found in this pocket is presented to any Authorized Volkswagen Dealer, between 250 and 450 miles, the service listed on the back of this coupon

W 1

**Oil Change and Maintenance Service 300 miles**