

## BODY

00	Body	-
05	Front section	38
09	Quarter panel	39
13	Rear section	40
17	Roof	41
19	Fresh air control	A 41
	from Ch. No. 311 2000 001	
	(to Ch. No. 310 2500 000 - see illustration 15)	
21	Fender	42
99	Body to chassis securing parts	42
23	Front hood	43
27	Rear hood	44
27	Rear door	44
31	Doors	45
37	Door components	45
45	Window glasses and weatherstrips	46
47	Quarter window parts	46
53	Moldings	47
57	Instrument panel fittings, ashtray	48
57	Instrument panel fittings, sun vizer, grab handles	A 48
57	Safety belt	B 48
60	Mounting parts for first aid kit	B 48
63	Front panel lining and floor covering	49
67	Interior trim	50
77	Steel sliding roof	51
81	Front seat	52
85	Rear seat	53
98	Repair kits	-

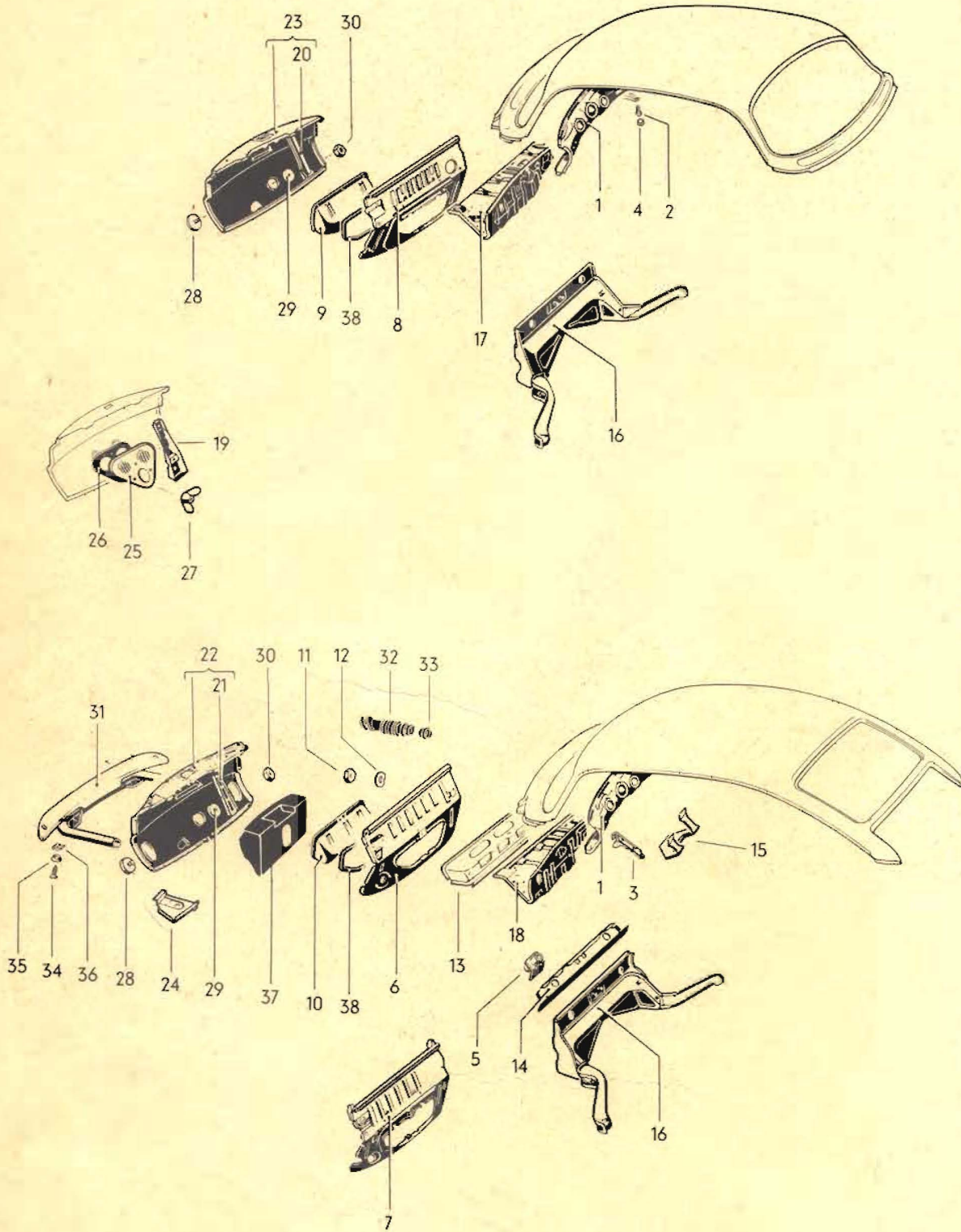

**MAIN GROUP 8****BODY**

Key	Part No.	Description	Qty.	Type and model
<b>BODY</b>				
-	311 800 101 R	Body, finished, without seats, glazed	1	M 236: 311
-	311 800 101 T	Body, finished, without seats, glazed	1	311
-	312 800 101 T	Body, finished, without seats, glazed	1	312
-	313 800 101 R	Body, finished, without seats, glazed	1	M 236: 313
-	313 800 101 T	Body, finished, without seats, glazed	1	313
-	314 800 101 T	Body, finished, without seats, glazed	1	314
-	315 800 101 T	Body, finished, without seats, glazed	1	315
-	315 800 101 H	Body, finished, without seats, glazed	1	M 234: 315
-	316 800 101 T	Body, finished, without seats, glazed	1	316
-	316 800 101 H	Body, finished, without seats, glazed	1	M 234: 316
-	317 800 101 T	Body, finished, without seats, glazed	1	317
-	317 800 101 H	Body, finished, without seats, glazed	1	M 234: 317

-	318 800 101 T	Body, finished, without seats, glazed	1	318
-	318 800 101 H	Body, finished, without seats, glazed	1	M 234: 318
-	361 800 101 R	Body, finished, without seats, glazed	1	M 236: 361
-	361 800 101 T	Body, finished, without seats, glazed	1	361
-	362 800 101 T	Body, finished, without seats, glazed	1	362
-	363 800 101 R	Body, finished, without seats, glazed	1	M 236: 363
-	363 800 101 T	Body, finished, without seats, glazed	1	363
-	364 800 101 T	Body, finished, without seats, glazed	1	364
-	365 800 101 R	Body, finished, without seats, glazed	1	M 236: 365
-	365 800 101 T	Body, finished, without seats, glazed	1	365
-	366 800 101 T	Body, finished, without seats, glazed	1	366
-	367 800 101 R	Body, finished, without seats, glazed	1	M 236: 367
-	367 800 101 T	Body, finished, without seats, glazed	1	367
-	368 800 101 T	Body, finished, without seats, glazed	1	368

-	311 800 701 CD	Body bare, without fenders, hoods and doors from Ch. No. 316 000 001 to 310 2500 000 (to Ch. No. 310 2500 000 see Parts Bulletin 8/8)	1	311
-	311 800 701 CG	Body bare, without fenders, hoods and doors from Ch. No. 311 2000 001	1	311
-	311 800 701 CH	Body bare, without fenders, hoods and doors from Ch. No. 311 2000 001	1	M 236: 311
-	312 800 701 CG	Body bare, without fenders, hoods and doors from Ch. No. 316 000 001 (to Ch. No. 310 2500 000 see Parts Bulletin 8/8)	1	312
-	313 800 701 CG	Body bare, without fenders, hoods and doors from Ch. No. 316 000 001 (to Ch. No. 310 2500 000 see Parts Bulletin 8/8)	1	313
-	313 800 701 CH	Body bare, without fenders, hoods and doors from Ch. No. 311 2000 001	1	M 236: 313
-	314 800 701 CG	Body bare, without fenders, hoods and doors from Ch. No. 316 000 001 (to Ch. No. 310 2500 000 see Parts Bulletin 8/8)	1	314
-	315 800 701 CD	Body bare, without fenders hoods and doors to Ch. No. 315 220 883 from Ch. No. 221 975 to 318 500 000 from Ch. No. 317 000 001 to 318 500 000 from Ch. No. 319 000 001 to 310 2500 000 (to Ch. No. 310 2500 000 see Parts Bulletin 8/8)	1 1 1 1	311 315 M 234: 315 315, M 234: 315

-	315 800 701 C G	Body bare, without fenders, hoods and doors from Ch. No. 311 2000 001	1	315, M 234: 315
-	316 800 701 C G	Body bare, without fenders, hoods and doors to Ch. No. 315 220 883 from Ch. No. 221 975 to 318 500 000 from Ch. No. 317 000 001 to 318 500 000 from Ch. No. 319 000 001 (to Ch. No. 310 2500 000 see Parts Bulletin 8/8)	1 1 1 1	316, M 234: 316 312 316 M 234: 316 316, M 234: 316
-	317 800 701 C B	Body bare, without fenders, hoods and doors to Ch. No. 315 220 883 from Ch. No. 221 975 to 318 500 000 from Ch. No. 317 000 001 to 318 500 000 from Ch. No. 319 000 001 to 319 500 000 (to Ch. No. 319 500 000 see Parts Bulletin 8/8)	1 1 1 1	313 317 M 234: 317 317; M 234: 317
-	317 800 701 C D	Body bare, without fenders, hoods and doors from Ch. No. 310 2000 001 to 310 2500 000	1	317; M 234: 317
-	317 800 701 C G	Body bare, without fenders, hoods and doors from Ch. No. 311 2000 001	1	317, M 234: 317
-	318 800 701 C G	Body bare, without fenders, hoods and doors to Ch. No. 315 220 883 from Ch. No. 221 975 to 318 500 000 from Ch. No. 317 000 001 to 318 500 000 from Ch. No. 319 000 001 (to Ch. No. 310 2500 000 see Parts Bulletin 8/8)	1 1 1 1	318, M 234: 318 314 318 M 234: 318 318; M 234: 318
-	361 800 701 C D	Body bare, without fenders, hoods, rear door and doors to Ch. No. 360 2500 000 (to Ch. No. 369 500 000 see Parts Bulletin 8/8)	1	361, 365
-	361 800 701 C G	Body bare, without fenders, hoods and doors from Ch. No. 361 2000 001	1	361, 365

-	361 800 701 CH	Body bare, without fenders, hoods and doors from Ch. No. 361 2000 001	1	M 236: 361, 365
-	362 800 701 CD	Body bare, without fenders, hoods, rear door and doors to Ch. No. 360 2500 000 (to Ch. No. 360 2500 000 see Parts Bulletin 8/8)	1	362, 366
-	362 800 701 CG	Body bare, without fenders, hoods and doors from Ch. No. 361 2000 001	1	362, 366
-	363 800 701 CG	Body bare, without fenders, hoods and doors (to Ch. No. 360 2500 000 see Parts Bulletin 8/8)	1	363, 367
-	363 800 701 CH	Body bare, without fenders, hoods and doors from Ch. No. 361 2000 001	1	M 236: 363, 367
-	364 800 701 CG	Body bare, without fenders, hoods and doors (to Ch. No. 360 2500 000 see Parts Bulletin 8/8)	1	364, 368

#### FRONT PORTION

1	311 805 051 AH	Instrument panel to Ch. No. 310 2500 000	1	311, 313, 315, 317, 361, 363, 365, 367
-	311 805 051 BA	Instrument panel from Ch. No. 311 2000 001	1	311, 313, 315, 317, 361, 363, 365, 367
-	312 805 051 F	Instrument panel to Ch. No. 319 121 436 use: to Ch. No. 317 500 000 312 805 144	1	312, 314, 316, 318, 362, 364, 366, 368
-	312 805 051 AD	Instrument panel from Ch. No. 319 121 437 to 319 500 000	1	312, 314, 316, 318, 362, 364, 366, 368
-	312 805 051 AH	Instrument panel from Ch. No. 310 2000 000 to 310 2500 000	1	312, 314, 316, 318, 362, 364, 366, 368
-	312 805 051 BA	Instrument panel from Ch. No. 311 2000 001	1	312, 314, 316, 318, 362, 364, 366, 368
-	311 805 133 A	Bracket for instrument panel from Ch. No. 311 2000 001	1	
-	N 12 227 3	Spring washer A 6 from Ch. No. 311 2000 001	2	
-	N 14 138 9	Screw, fillister hd. AM 6 x 10 from Ch. No. 311 2000 001	2	



-	311 805 139 C	Bracket - Instrument panel from Ch. No. 318 000 001 to 310 2500 000	1	
2	311 805 141	Screw, fillister head for instrument panel support to Ch. No. 290 000	2	
3	311 805 144	Bracket for instrument panel to Ch. No. 317 500 000	1	311,313,315,317, 361,363,365,367
		from Ch. No. 319 121 437	1	311,313,315,317, 361,363,365,367
-	312 805 144	Bracket for instrument panel to Ch. No. 317 500 000	1	312,314,316,318, 362,364,366,368
		from Ch. No. 319 121 437	1	312,314,316,318, 362,364,366,368
4	311 805 149	Cap - Screw, fillister hd.	2	
5	311 805 251 B	Support - Steering column tube on front cross panel from Ch. No. 318 000 001	1	311,313,315,317, 361,363,365,367
-	312 805 251 A	Support - Steering column tube on front cross panel from Ch. No. 318 000 001 to 319 500 000	1	312,314,316,318, 362,364,366,368
-	312 805 251 B	Support - Steering column tube on front cross panel from Ch. No. 310 2000 001	1	312,314,316,318, 362,364,366,368
6	311 805 391 G	Carrier - Spare wheel well from Ch. No. 310 2000 001	1	
7	311 805 391 J	Carrier - Spare wheel well from Ch. No. 318 000 001 to 319 500 000	1	
8	311 805 391 K	Carrier - Spare wheel well to Ch. No. 317 500 000	1	
9	311 805 395	Well - Spare wheel to Ch. No. 319 500 000	1	
10	311 805 395 C	Well - Spare wheel from Ch. No. 310 2000 001	1	
11	N 11 006 2	Nut, hex. M 6	1	
12	N 12 226 2	Spring washer B 6	1	
13	311 805 379	Carrier, front for fuel tank from Ch. No. 310 2000 001	1	
-	311 805 419	Reinforcement - Cross panel from Ch. No. 318 000 001 to 319 500 000	1	
14	311 805 419 A	Reinforcement - Cross panel from Ch. No. 310 2000 001	1	
-	311 805 427	Bracket - Instrument panel from Ch. No. 318 000 001 to 319 121 436	1	
15	311 805 427 B	Support - Steering column tube from Ch. No. 319 121 437 to 310 2500 000	1	

-	311 805 427 C	Support - Steering column tube from Ch. No. 311 2000 001	1	
-	311 805 429	Bracket - Instrument panel from Ch. No. 319 121 437 to 319 500 000	1	312,314,316,318, 362,364,366,368
16	311 805 441 E	Cross panel, front	1	311,313,315,317, 361,363,365,367
-	312 805 441 C	Cross panel, front to Ch. No. 319 500 000	1	312,314,316,318, 362,364,366,368
-	312 805 441 E	Cross panel, front from Ch. No. 310 2000 001	1	312,314,316,318, 362,364,366,368
17	311 805 451 J	Luggage compartment, front to Ch. No. 319 500 000	1	
18	311 805 451 G	Luggage compartment, front from Ch. No. 310 2000 001 to 310 2500 000	1	
-	311 805 451 L	Luggage compartment, front from Ch. No. 311 2000 001	1	
19	311 805 567 A	Support - Front panel to Ch. No. 483 592	1	
20	311 805 569 B	Support - Front panel from Ch. No. 315 000 001 to 319 500 000	2	
21	311 805 569 D	Support - Front panel from Ch. No. 310 2000 001	1	
22	311 805 591 J	Front panel from Ch. No. 310 2000 001	1	
-	311 805 591 K	Front panel from Ch. No. 318 000 001 to 319 500 000	1	
23	311 805 591 L	Front panel to Ch. No. 317 500 000	1	
24	311 805 625	Corner plate - Fluid container for windshield washer from Ch. No. 310 2000 001	1	
25	311 805 657 A	Cover - Front panel to Ch. No. 483 592	1	
26	311 805 659 A	Seal for cover to Ch. No. 483 592	1	
27	N 11 173 1	Wing nut M 5	3	
28	311 805 655 B	Support outer - Front panel from Ch. No. 315 000 001	1	
29	311 805 675	Support inner - Front panel from Ch. No. 315 000 001	1	
30	N 11 005 2	Nut, hex. M 5	1	
-	311 805 693	Support - Bumper, front from Ch. No. 318 000 001 to 319 500 000	1	
31	311 805 693 A	Support - Bumper, front from Ch. No. 310 2000 001	1	
-	311 805 703	Grommet - Support from Ch. No. 318 000 001 to 319 500 000	2	
32	311 805 703 A	Grommet - Support from Ch. No. 310 2000 001	1	

33	311 805 707	Plug - Support from Ch. No. 318 000 001	2	
34	N 14 108 1	Tapping screw, skc. raised hd. B 5.5 x 16	2	
35	N 11 584 1	Concave washer 5.8	2	
36	N 15 431 1	Speed nut 5.5	2	
37	311 805 739	Foam padding for front panel from Ch. No. 318 000 001 to 319 500 000	1	M 239, M 242
38	311 805 761	Seal - Spare wheel well	1	



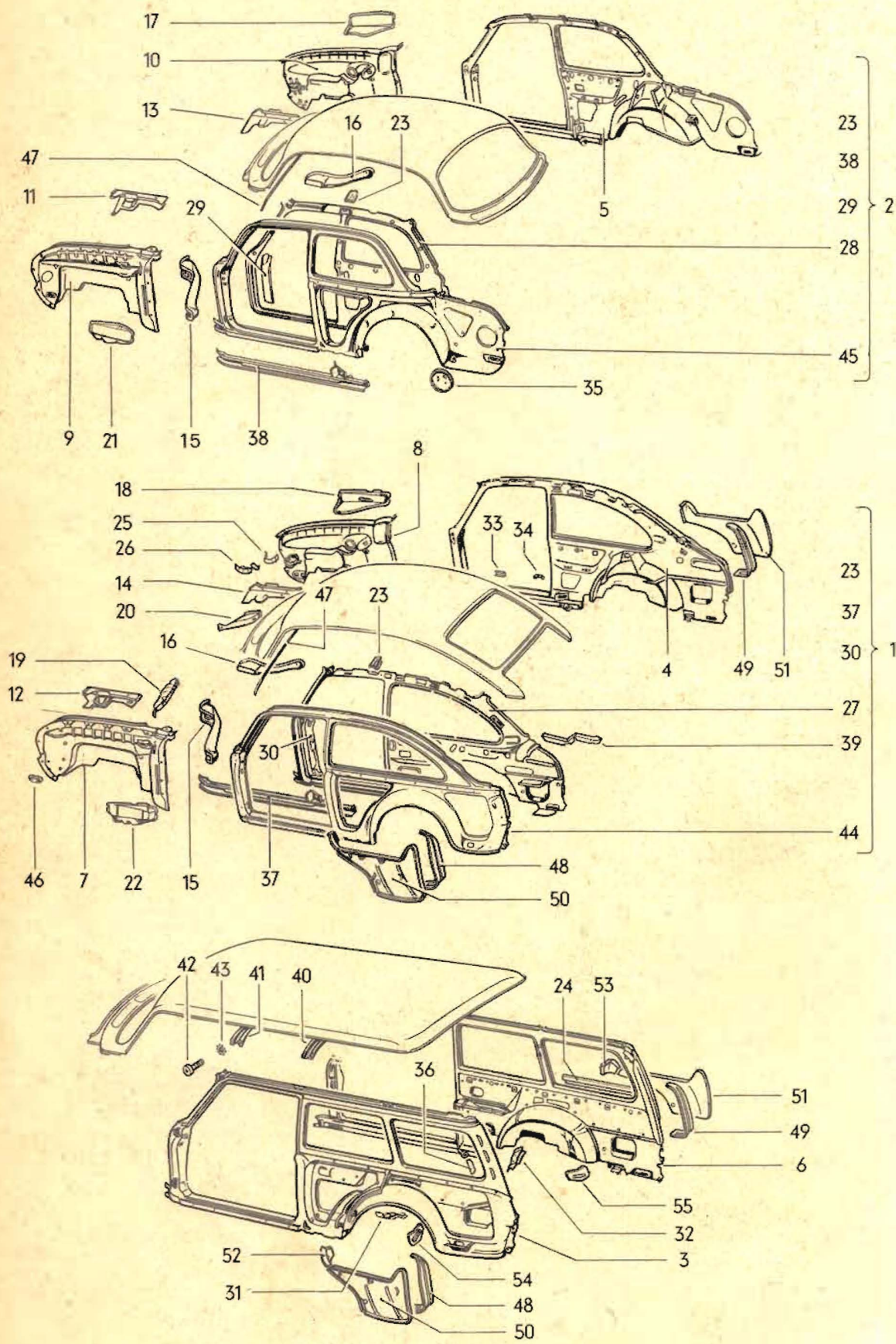

**MAIN GROUP 8**

**BODY**

Key	Part No.	Description	Qty.	Type and model
<b>QUARTER PANEL</b>				
(1)	313 809 029	Quarter panel, outer and inner, left to Ch. No. 221 974	1	313, 314
1	313 809 029 BA	Quarter panel, outer and inner, left from Ch. No. 316 000 001 use 111 837 035 D to Ch. No. 316 500 000	1	311-314
(1)	313 809 029 AR	*Quarter panel, outer and inner, left from Ch. No. 311 2000 001	1	M 236: 311-314
(2)	317 809 029 S	Quarter panel, outer and inner, left to Ch. No. 315 220 883 from Ch. No. 316 000 001 use 111 837 035 D to Ch. No. 316 500 000	1 1 1	315-318 311-318 315-318
2	317 809 029 AD	Quarter panel, outer and inner, left from Ch. No. 311 2000 001	1	315-318
(3)	363 809 029 K	Quarter panel, outer and inner, left use 111 837 035 D to Ch. No. 366 500 000	1	361-368
(3)	363 809 029 BA	Quarter panel, outer and inner, left from Ch. No. 361 2000 001 to 361 2500 000	1	361-368
(3)	363 809 029 AR	*Quarter panel, outer and inner, left from Ch. No. 361 2000 001 to 361 2500 000	1	M 236: 361-368
3	363 809 029 BE	Quarter panel, outer and inner, left from Ch. No. 362 2000 001	1	361-368
(3)	363 809 029 BF	*Quarter panel, outer and inner, left from Ch. No. 362 2000 001	1	M 236: 361-368
4	313 809 030 BA	Quarter panel, outer and inner, right from Ch. No. 316 000 001 use 111 837 036 D to Ch. No. 316 500 000	1	311-314

5	317 809 030 AD	Quarter panel, outer and inner, right to Ch. No. 315 220 883 from Ch. No. 316 000 001 use 111 837 036 D to Ch. No. 316 500 000	1 1	311-318 315-318
(6)	363 809 030 N	Quarter panel, outer and inner, right from Ch. No. 310 2500 000 use 111 837 036 D to Ch. No. 366 500 000	1	361-368
(6)	363 809 030 BA	Quarter panel, outer and inner, right from Ch. No. 361 2000 001 to 361 2500 000	1	361-368
6	363 809 030 BE	Quarter panel, outer and inner, right from Ch. No. 362 2000 001	1	361-368
7	311 809 101 N	Wheel housing, front left from Ch. No. 310 2000 001	1	
8	312 809 102 N	Wheel housing, front right from Ch. No. 310 2000 001	1	
9	311 809 103	Wheel housing, front left to Ch. No. 319 500 000 (see Workshop Bulletin A-85)	1	
10	311 809 104 A	Wheel housing, front right to Ch. No. 319 500 000 (see Workshop Bulletin A-85)	1	
-	N 20 025 1	Plug A 22 x 1 for sealing off the parking lamp cable hole	2	315-318, 365-368
11	311 809 115 A	Support, left for fuel tank to Ch. No. 319 500 000	1	
12	311 809 115 B	Support, left for fuel tank from Ch. No. 310 2000 001	1	
13	311 809 116 B	Support, right for fuel tank to Ch. No. 319 500 000	1	
14	311 809 116 A	Support, right for fuel tank from Ch. No. 310 2000 001	1	
-	111 809 117	Bracket for brake fluid reservoir	1	
15	311 809 133 A	Side member, front, left	1	
16	311 809 134 A	Side member, front, right	1	

17	311 809 176	Reinforcement, outer for wheel housing, front right from Ch. No. 318 000 001 to 319 500 000	1	
18	311 809 176 A	Reinforcement, outer for wheel housing, front right from Ch. No. 310 2000 001	1	
19	311 809 177	Reinforcement, inner for wheel housing, front left from Ch. No. 318 000 001	1	
20	311 809 178	Reinforcement, inner for wheel housing, front right from Ch. No. 318 000 001	1	
21	311 809 179	Reinforcement, outer for wheel housing, front left from Ch. No. 318 000 001 to 319 500 000	1	
22	311 809 179 A	Reinforcement, outer for wheel housing, front left from Ch. No. 310 2000 001	1	
(23)	363 809 215 A	Support between quarter panel and steel sliding roof to Ch. No. 317 500 000	6	313, 314, 317, 318 363, 364, 367, 368
23	313 809 217 A	Support, left between quarter panel and steel sliding roof from Ch. No. 318 000 001	3	313, 314, 317, 318, 363, 364, 367, 368
(23)	313 809 218	Support, right between quarter panel and steel sliding roof from Ch. No. 318 000 001	3	313, 314, 317, 318 363, 364, 367, 368
24	365 809 255	Retaining strip for rear luggage compartment lining up to Ch. No. 365 220 883	2	365-368
-	365 809 271 A	Side window panel, front, left	1	M 265
-	365 809 272 A	Side window panel, front, right	1	M 265
-	365 809 273 A	Side window panel, rear, left	1	M 265
-	365 809 274 A	Side window panel, rear, right	1	M 265
(25)	111 809 371 B	Bracket - Jack to Ch. No. 311 2500 000	1	
25	111 809 373 E	Bracket - Jack from Ch. No. 312 2000 001	1	
26	111 809 376	Retaining spring for jack from Ch. No. 312 2000 001	1	
(27)	311 809 405	Quarter panel, inner, left to Ch. No. 221 974	1	311-314



(27)	311 809 405 E	Quarter panel, inner, left from Ch. No. 316 000 001 to 317 500 000	1	311-314
(27)	311 809 405 H	Quarter panel, inner, left from Ch. No. 318 000 001 to 310 2500 000	1	311-314
(27)	311 809 405 AA	Quarter panel, inner, left from Ch. No. 311 2000 001	1	311-314
(28)	315 809 405 C	Quarter panel, inner, left from Ch. No. 221 975 to 315 220 883	1	311-318
		from Ch. No. 316 000 001 to 310 2500 000	1	315-318
28	315 809 405 AA	Quarter panel, inner, left from Ch. No. 311 2000 001	1	315-318
(27)	311 809 406	Quarter panel, inner, right to Ch. No. 221 974	1	311-314
(28)	311 809 406 B	Quarter panel, inner, right from Ch. No. 221 975 to 315 220 883	1	311-318
		from Ch. No. 316 000 001 to 316 500 000	1	315-318
(27)	311 809 406 H	Quarter panel, inner, right from Ch. No. 316 000 001 to 317 500 000	1	311-314
(27)	311 809 406 M	Quarter panel, inner, right from Ch. No. 318 000 001 to 310 2500 000	1	311-314
(27)	311 809 406 AA	Quarter panel, inner, right from Ch. No. 311 2000 001	1	311-314
(28)	315 809 406	Quarter panel, inner, right from Ch. No. 317 000 001 to 317 500 000	1	315-318
(28)	315 809 406 D	Quarter panel, inner right from Ch. No. 318 000 001 to 310 2500 000	1	315-318
(28)	315 809 406 AA	Quarter panel, inner, right from Ch. No. 311 2000 001	1	315-318
29	311 809 421 A	Cover plate, inner for hinge pillar, left to Ch. No. 315 220 883	1	
		from Ch. No. 316 000 001	1	315-318
(30)	311 809 421 B	Cover plate, inner for hinge pillar, left from Ch. No. 316 000 001 to 317 500 000	1	311-314, 361-368
30	365 809 421	Cover plate, inner for hinge pillar, left from Ch. No. 318 000 001	1	311-314, 361-368
(29)	311 809 422 A	Cover plate, inner for hinge pillar, right to Ch. No. 315 220 883	1	
		from Ch. No. 316 000 001	1	315-318
(30)	311 809 422 B	Cover plate, inner for hinge pillar, right from Ch. No. 316 000 001 to 317 500 000	1	311-314, 361-368
(30)	365 809 422	Cover plate, inner for hinge pillar, right from Ch. No. 318 000 001	1	311-314, 361-368

31	361 809 449 A	Reinforcement between quarter panel left and luggage compartment floorplate from Ch. No. 368 000 001	1	361-368
32	361 809 450 A	Reinforcement between quarter panel right and luggage compartment floorplate from Ch. No. 368 000 001	1	361-368
33	311 809 455 B	Support for backrest lock to Ch. No. 317 500 000	1	311-314, 361-364; M 234: 315-318
34	311 809 481	Support - Arm rest to Ch. No. 317 500 000	4	311-314
(35)	311 809 493 A	Cover - Quarter panel to Ch. No. 315 220 883	2	311-318
		from Ch. No. 316 000 001 to 311 2500 000	2	315-318
35	311 809 495 A	Cover - Quarter panel from Ch. No. 312 2000 001	2	315-318
36	361 809 497	Cover plate for ventilation slots to Ch. No. 310 2500 000	6	361-368
37	311 809 511 B	Side member, left from Ch. No. 316 000 001	1	311-314, 361-368
38	315 809 511 A	Side member, left to Ch. No. 315 220 883	1	
		from Ch. No. 316 000 001	1	315-318
(37)	311 809 512 B	Side member, right from Ch. No. 316 000 001	1	311-314, 361-368
(38)	315 809 512 A	Side member, right to Ch. No. 315 220 883	1	
		from Ch. No. 316 000 001	1	315-318
39	311 809 545 A	Bracket, left for Parcel shelf, rear from Ch. No. 311 2000 001	2	311-314
(39)	311 809 546 A	Bracket, right for Parcel shelf, rear from Ch. No. 311 2000 001	2	311-314
40	361 809 559	Bow - Roof, center	1	361-368
41	361 809 563	Bow - Roof, front	1	361, 362, 365, 366
42	N 14 130 1	Screw, fillister hd. AM 5 x 11	8	361-368
43	N 12 104 2	Spring washer A 5.3	8	361-368
(44)	311 809 601 D	Quarter panel, outer, left from Ch. No. 316 000 001 to 310 2500 000	1	311-314
44	311 809 601 N	Quarter panel, outer left from Ch. No. 311 2000 001	1	311-314
45	315 809 601 N	Quarter panel, outer left to Ch. No. 315 220 883	1	311-318
		from Ch. No. 316 000 001	1	315-318
(45)	311 809 602 N	Quarter panel, outer right from Ch. No. 316 000 001	1	311-314

(45)	315 809 602 N	Quartel panel, outer right	1	315-318
		to Ch. No. 315 220 883	1	311-318
		from Ch. No. 316 000 001	1	315-318
(45)	311 809 605 E	Quarter panel, outer, left	1	311-314
		(without mounting parts)		
46	361 809 639	Retaining clamp – Bumper bracket	4	
47	313 809 667 A	Water darin pipe, front left	1	313, 314, 317, 318, 363, 364, 367, 368
(47)	313 809 668 A	Water darin pipe, front right	1	313, 314, 317, 318, 363, 364, 367, 368
48	361 809 805 B	End plate		
		for air passage, left		
		to Ch. No. 315 220 883	1	361-368
		from Ch. No. 316 000 001	1	311-314, 361-368
49	361 809 806 B	End plate		
		for air passage, right		
		to Ch. No. 315 220 883	1	361-368
		from Ch. No. 316 000 001	1	311-314, 361-368
50	311 809 809	Cover – Air passage, left	1	311-314, 361-368
		use:		
		361 809 811 A/N 20 007 1		
		to Ch. No. 221 974		
		from Ch. No. 221 975		
		361 809 811 C		
		for Models 361-368		
51	311 809 810	Cover – Air passage, right	1	311-314, 361-368
		use:		
		361 809 812 A/N 20 007 1		
		to Ch. No. 221 974		
		from Ch. No. 221 975		
		for Models 361-368		
		361 809 812 C		
(52)	361 809 811 A	Front part, cover	1	361-364
		for air passage left		
		to Ch. No. 221 974		
52	361 809 811 C	Front part, cover	1	361-368
		for air passage left		
		from Ch. No. 366 000 001		
(53)	361 809 812 A	Front part, cover	1	361-364
		for air passage right		
		to Ch. No. 221 974		
53	361 809 812 C	Front part cover	1	361-368
		for air passage right		
		from Ch. No. 366 000 001		

54	361 809 835 A	Protection plate, left between engine compartment cover plate and quarter panel from Ch. No. 221 975 to 315 220 883	1	361-368
		from Ch. No. 316 000 001 to 317 500 000	1	311-314, 361-368
55	361 809 836 A	Protection plate, right between engine compartment cover plate and quarter panel from Ch. No. 221 975 to 315 220 883	1	361-368
		from Ch. No. 316 000 001 to 317 500 000	1	311-314, 361-368
-	311 809 841	Lock pillar part of quarter panel, outer, left	1	
-	311 809 842	Lock pillar part of quarter panel, outer, right	1	
-	311 809 845 C	Side member section of quarter panel, inner, left from Ch. No. 221 975	1	311-314, 361-368 315-318
-	311 809 846 C	Side member section of quarter panel, inner, left from Ch. No. 221 975	1	311-314, 361-368 315-318
-	311 809 847 C	Side member section of quarter panel, outer, left	1	
-	311 809 848 C	Side member section of quarter panel, outer, right	1	
-	311 809 849	Rear part of quarter panel, outer, left	1	315-318
-	311 809 850	Rear part of quarter panel, outer, right	1	315-318





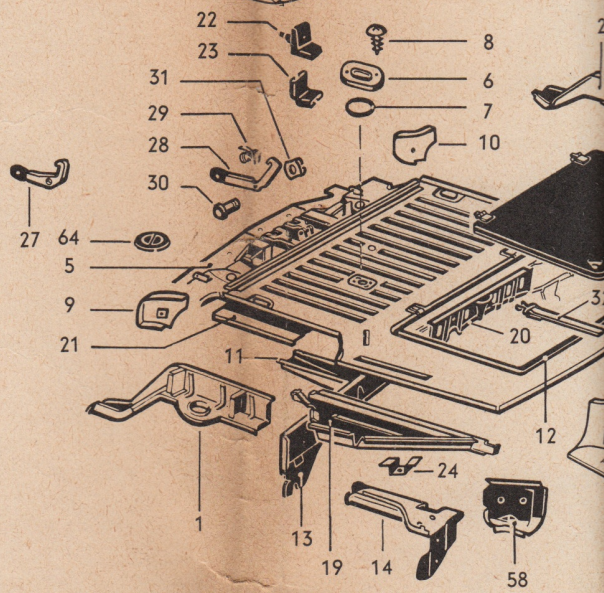
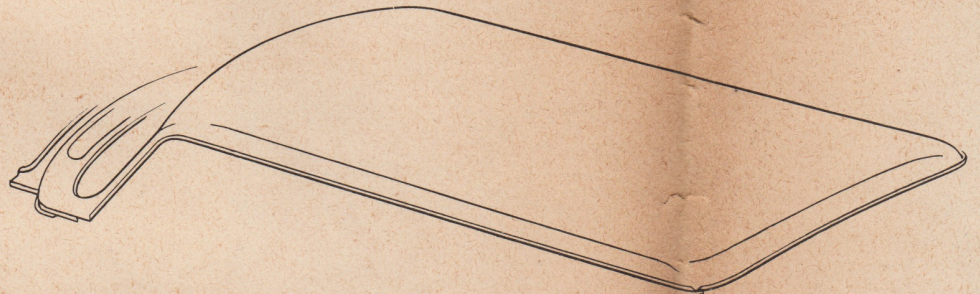
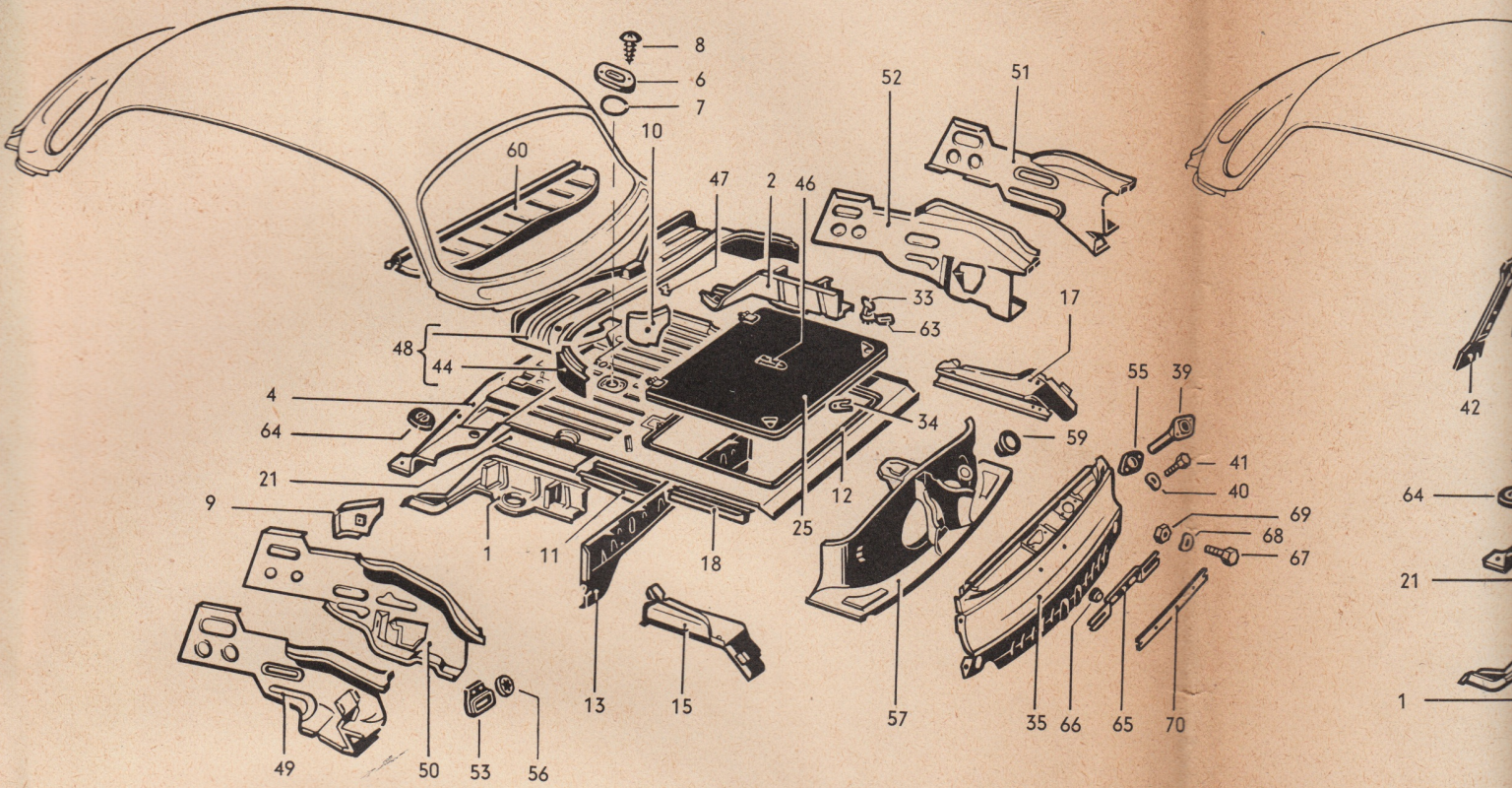

Rear portion

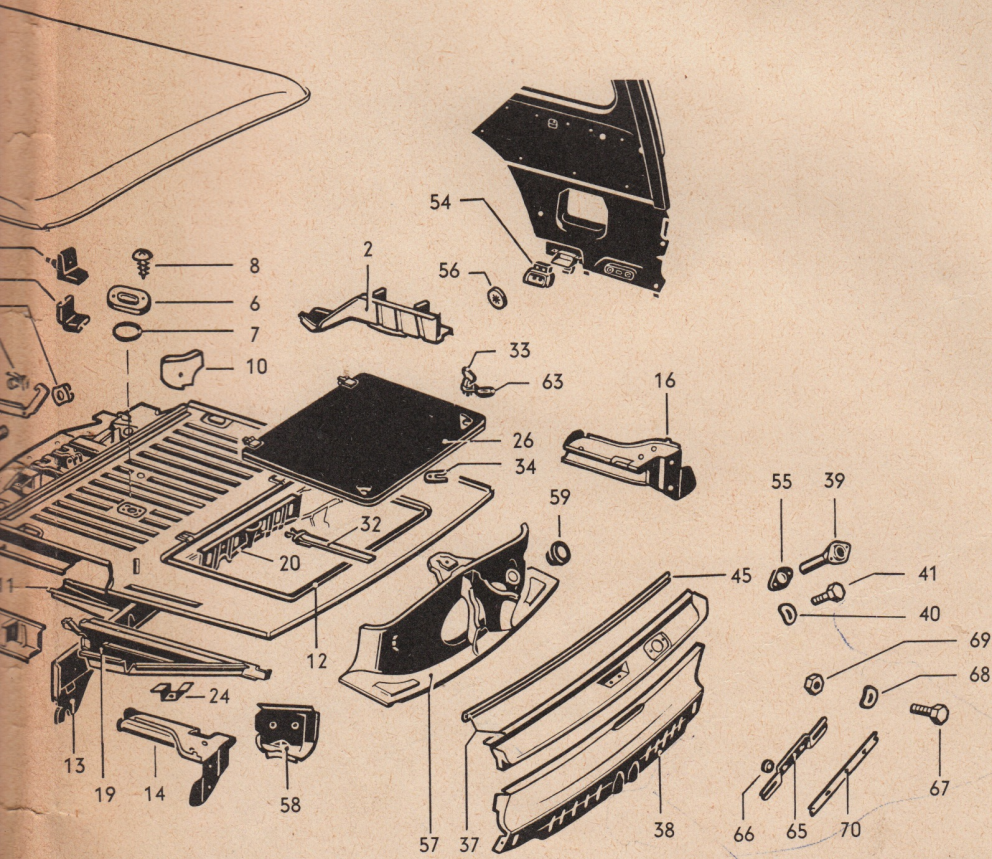
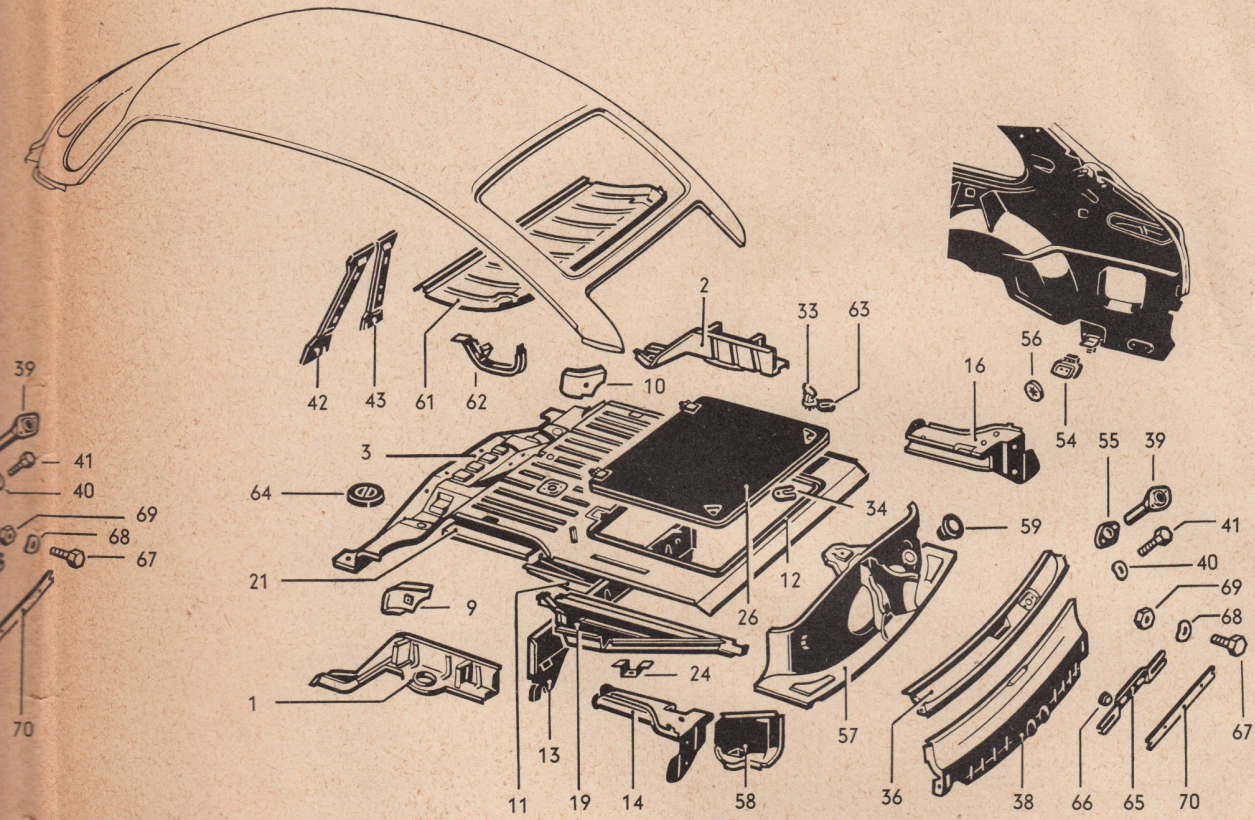



**MAIN GROUP 8**

**BODY**

Key	Part No.	Description	Qty.	Type and model
<b>REAR SECTION</b>				
1	361 813 073 E	Support, left – Body mounting, rear on sub-frame	1	
2	361 813 074 E	Support, right – Body mounting, rear on sub-frame	1	
3	311 813 111 K	Floorplate – Luggage compartment, rear with heating pipe from Ch. No. 316 000 001 use: 411 805 415/419 B/N 13 965 1	1	311-314
4	315 813 113 B	Luggage compartment floorplate without heating pipe to Ch. No. 315 220 883 from Ch. No. 316 000 001 use: 411 805 415/419 B/N 13 965 1	1 1	311-318 315-318
5	361 813 113 C	Luggage compartment floorplate without heating pipe use: 411 805 415/419 B/N 13 965 1	1	361-368
6	411 805 415	*Cover (oval) from Ch. No. 319 108 900 to 319 500 000	1	M 60
7	411 805 419 B	*Seal – Cover from Ch. No. 319 108 900 to April 1969	1	M 60
8	N 13 965 1	Tapping screw, fillister hd. B 4.2 x 9.2	1	M 60
9	311 809 765 C	Mounting plate, left – Safety belt to luggage compartment floorplate	1	
10	311 809 766 A	Mounting plate, right – Safety belt to luggage compartment floorplate	1	
11	311 813 117	Reinforcement, center for luggage compartment floor	1	
12	311 813 133 A	Seal – Engine compartment lid	1	
13	311 813 151 D	Cover plate, front – Engine compartment to Ch. No. 311 2228 288	1	
-	311 813 151 E	Cover plate, front – Engine compartment from Ch. No. 311 2228 289	1	
-	361 813 159	Reinforcement – Cover plate to Ch. No. 317 134 445	1	361-368
14	311 813 161 A	Cover plate, left – Engine compartment from Ch. No. 221 975 to 317 500 000 from Ch. No. 318 000 001	1 1	311-314, 361-368
15	315 813 161	Cover plate, left – Engine compartment from Ch. No. 318 000 001	1	315-318

16	311 813 162 A	Cover plate, right – Engine compartment from Ch. No. 221 975 to 317 500 000	1	
		from Ch. No. 318 000 001	1	311-314,361-368
17	315 813 162	Cover plate, right – Engine compartment from Ch. No. 318 000 001	1	315-318
-	311 813 165	Cover plate, left – Engine compartment to Ch. No. 221 974	1	
-	311 813 166	Cover plate, right – Engine compartment to Ch. No. 221 974	1	
18	311 813 167	Reinforcement, left – Luggage compartment floorplate from Ch. No. 221 975 to 315 220 883	1	311-318
		from Ch. No. 316 000 001	1	315-318
19	361 813 167 A	Reinforcement, left – Luggage compartment floorplate from Ch. No. 221 975 to 315 220 883	1	361-368
		from Ch. No. 316 000 001 to 311 2500 000	1	311-314,361-368
-	361 813 167 B	Reinforcement, left – Luggage compartment floorplate from Ch. No. 310 2000 001	1	M 26
-	311 813 163	Reinforcement, left – Luggage compartment floorplate from Ch. No. 312 2000 001	1	311-314, 361-368
-	311 813 168	Reinforcement, right – Luggage compartment floorplate from Ch. No. 221 975 to 315 220 883	1	311-318
		from Ch. No. 316 000 001	1	315-318
-	361 813 168 A	Reinforcement – Luggage compartment floorplate from Ch. No. 221 975 to 315 220 883	1	361-368
		from Ch. No. 316 000 001	1	311-314, 361-368
-	361 813 169	Reinforcement – Cover plate from Ch. No. 367 134 446 to 368 500 000	1	361-368
20	361 813 169 A	Reinforcement – Cover plate from Ch. No. 369 000 001	1	361-368
-	311 813 191	Screen plate, left – Luggage compartment floorplate from Ch. No. 195 275	1	
-	311 813 192	Screen plate, right – Luggage compartment floorplate from Ch. No. 195 275	1	
-	311 813 197	Screen plate for luggage compartment floorplate from Ch. No. 195 275 to 317 500 000	2	
21		No longer available		
22	361 813 215 A	Stop – Back rest to Ch. No. 367 500 000	2	361-368

23	361 813 215 B	Stop – Back rest from Ch. No. 368 000 001	2	361-368
24	311 813 221	Bracket for pressure sensor from Ch. No. 310 2000 001 to 310 2500 000	1	M 236
-	311 813 223	Engine compartment lid to Ch. No. 280 370	1	
25	311 813 223 A	Engine compartment lid from Ch. No. 280 371 to 315 220 883 from Ch. No. 316 000 001	1 1	315-318
26	311 813 223 B	Engine compartment lid from Ch. No. 316 000 001	1	311-314, 361-368
27	361 813 231	Retaining hook – Rear seat backrest to Ch. No. 367 500 000	1	361-368
28	361 813 231 A	Retaining hook – Rear seat backrest from Ch. No. 368 000 001	2	361-368
29	361 813 237	Spring – Retaining hook	1	361-368
-	361 813 241	Pin – Retaining hook to Ch. No. 367 500 000	1	361-368
-	N 12 436 2	Lock washer 6	1	361-368
30	N 13 271 1	Pin 8 x 24 – Hook	1	361-368
31	N 12 858 1	Clamping plate	1	361-368
32	361 813 251	Retaining strap for engine compartment lid	1	361-368
33	311 813 295	Lock – Engine compartment lid	2	
-	N 20 022 3	Plug A 8 x 1 – Lock	2	
34	311 813 297	Retaining plate – Lock	2	
35	315 813 301	Rear apron to Ch. No. 315 220 883 from Ch. No. 316 000 001	1 1	311-318 315-318
36	311 813 307 A	Lock carrier plate for rear apron from Ch. No. 316 000 001	1	311-314
37	361 813 307	Lock carrier plate for rear apron to Ch. No. 311 2500 000	1	361-368
-	361 813 307 A	Lock carrier plate for rear apron from Ch. No. 312 2000 001	1	361-368
38	361 813 309	Rear apron to Ch. No. 365 220 883 from Ch. No. 316 000 001	1 1	361-368 311-314, 361-368
39	311 813 313 A	Oil filler neck use: to Ch. No. 311 2031 555 311 115 329 B	1	
40	N 12 226 2	Spring washer B 6	2	
41	N 10 210 7	Bolt, hex. hd. M 6 x 10 K	2	

-	311 813 321	Diagonal strut, left for rear parcel shelf to Ch. No. 315 220 883	1	311-318
		from Ch. No. 316 000 001	1	315-318
42	311 813 321 A	Diagonal strut, left for rear parcel shelf from Ch. No. 316 000 001	1	311-314
-	311 813 322	Diagonal strut, right for rear parcel shelf to Ch. No. 315 220 883	1	311-318
		from Ch. No. 316 000 001	1	315-318
43	311 813 322 A	Diagonal strut, right for rear parcel shelf from Ch. No. 316 000 001	1	311-314
44	311 813 327 A	Extension, left for air deflector plate, front to Ch. No. 315 220 883	1	311-318
		from Ch. No. 316 000 001	1	315-318
-	311 813 328 A	Extension, right for air deflector plate, front to Ch. No. 315 220 883	1	311-318
		from Ch. No. 316 000 001	1	315-318
45	361 813 329	Channel for weatherstrip, inner, lower for rear door	1	361-368
46	311 813 339	Catch spring for engine compartment lid to Ch. No. 315 220 883	1	311-318
		from Ch. No. 316 000 001	1	315-318
47	311 813 343	Catch plate for engine compartment lid to Ch. No. 315 220 883	1	311-318
		from Ch. No. 316 000 001	1	315-318
48	311 813 345	Air deflector plate, front to Ch. No. 315 220 883	1	311-318
		from Ch. No. 316 000 001	1	315-318
49		No longer available		
50	315 813 355 B	Air deflector plate, left to Ch. No. 315 220 883	1	311-318
		from Ch. No. 316 000 001	1	315-318
51		no longer available		
52	315 813 356 B	Air deflector plate, right to Ch. No. 315 220 883	1	311-318
		from Ch. No. 316 000 001	1	315-318
-	315 813 367	Cap - Water drain hose, left from Ch. No. 318 000 001	1	315-318
-	315 813 368	Cap - Water drain hose, right from Ch. No. 318 000 001	1	315-318

53	311 813 373	Water drain flap to Ch. No. 315 220 883	2	311-318
		from Ch. No. 316 000 001 to 317 500 000	2	315-318
54	361 813 373 A	Water drain flap to Ch. No. 315 220 883	2	361-368
		from Ch. No. 316 000 001	2	311-314, 361-368
		from Ch. No. 318 000 001	2	315-318
55	311 813 395	Gasket – Oil filler neck	1	
56	311 813 399	Speed nut for water drain flap	4	
57	311 813 411	Air deflector plate, rear	1	
-	111 801 177	Rubber valve for water drain hole	1	
58	361 813 417 C	Extension, left for air deflector plate, rear		
		to Ch. No. 315 220 883	1	361-368
		from Ch. No. 316 000 001	1	311-314, 361-368
-	361 813 418	Extension, right for air deflector plate, rear		
		to Ch. No. 315 220 883	1	361-368
		from Ch. No. 316 000 001 to 317 500 000	1	311-314, 361-368
-	361 813 418 A	Extension, right for air deflector plate, rear	1	311-314, 361-368
		from Ch. No. 318 000 001 to 318 500 000		
-	361 813 418 B	Extension, right for air deflector plate, rear	1	311-314, 361-368
		from Ch. No. 319 000 001		
59	311 813 453	Rubber ring for oil filler neck	1	
		to Ch. No. 310 2500 000		
60	311 813 651	Parcel shelf, rear to Ch. No. 315 220 883	1	311-318
		from Ch. No. 316 000 001	1	315-318
61	311 813 651 A	Parcel shelf, rear from Ch. No. 316 000 001 to 310 2500 000	1	311-314
-	311 813 651 B	Parcel shelf, rear from Ch. No. 311 2000 001 (see VW Parts Service Bulletin 8/39)	1	311-314
62	311 813 760	Protection bow for torsion bar from Ch. No. 316 000 001 to 310 2500 000	2	311-314
-	311 813 760 A	Protection bow for torsion bar from Ch. No. 311 2000 001	1	311-314
63	311 813 789 A	Catch – Lock	2	
64	311 813 797	Plug for luggage compartment floor	2	
-	315 813 897	Luggage compartment floorplate, rear part to Ch. No. 315 220 883	1	311-314
		from Ch. No. 221 975	1	315-318

-	311 813 897 B	Luggage compartment floorplate, rear part	1	361-368
		from Ch. No. 316 000 001	1	311-314
65	311 813 991 A	Bracket - Licence plate		
		from Ch. No. 421 606	1	311-318
		from Ch. No. 421 607	2	311-318
			1	361-368
66	311 821 185	Seal - Bracket	4	311-318
			2	361-368
67	N 10 210 7	Bolt, hex. hd. M 6 x 10 K	4	311-318
			2	361-368
68	N 12 226 2	Spring washer B 6	4	311-318
			2	361-368
69	N 11 106 1	Nut, hex. AM 6	2	
70	311 813 993	Reinforcement - Licence plate	X	



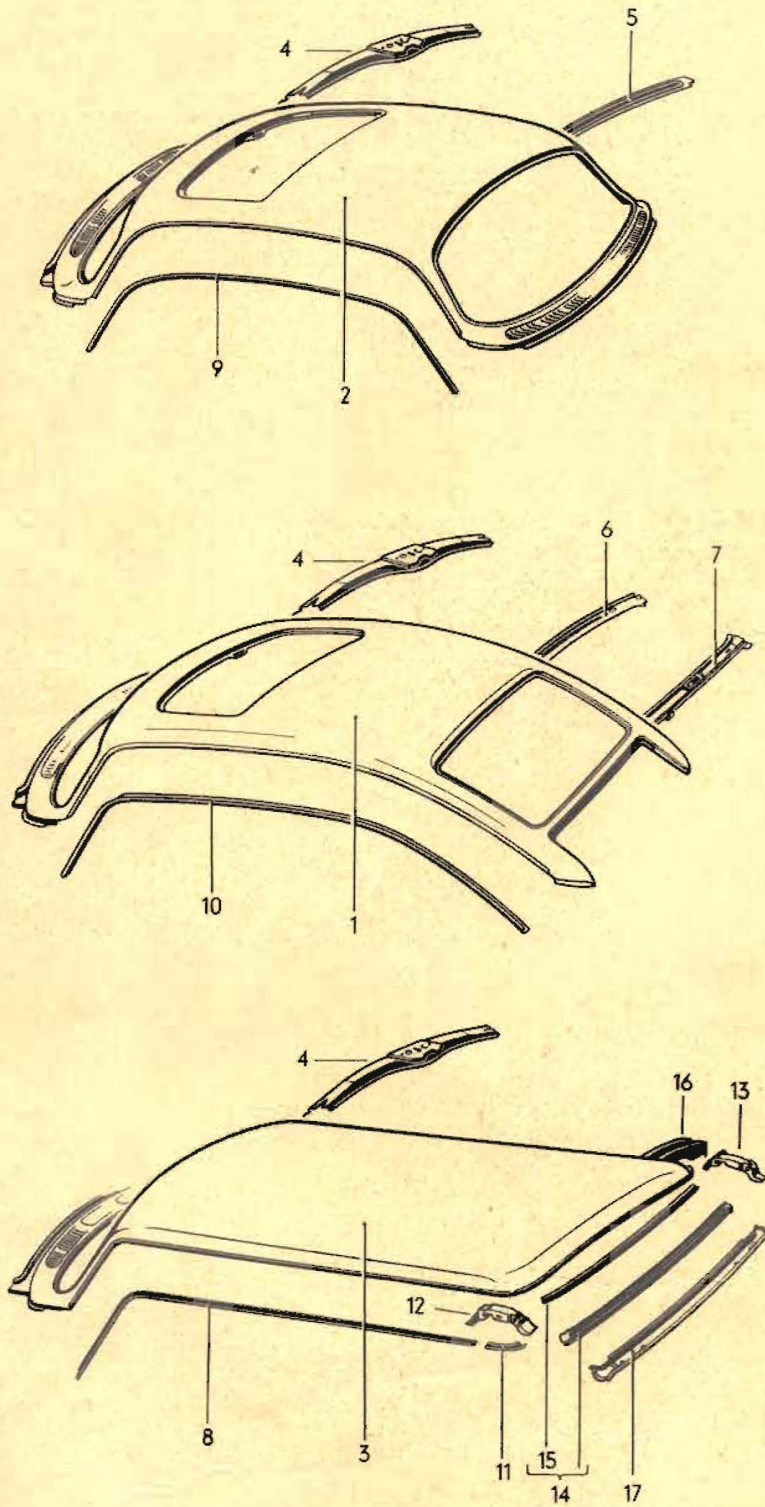



**MAIN GROUP 8**

**BODY**

Key	Part No.	Description	Qty.	Type and model
<b>ROOF</b>				
-	311 817 021 C	Roof from Ch. No. 316 000 001 to 310 2500 000	1	311, 312
-	311 817 021 E	Roof from Ch. No. 311 2000 001	1	311, 312
1	313 817 021 D	Roof (steel sliding roof) from Ch. No. 316 000 001 to 310 2500 000 use: 411 877 297	1	313, 314
-	313 817 021 E	Roof (steel sliding roof) from Ch. No. 311 2000 001	1	313, 314
-	315 817 021 A	Roof to Ch. No. 315 220 883	1	311, 312, 315, 316
		from Ch. No. 316 000 001 to 310 2500 000	1	315, 316
2	317 817 021 A	Roof (steel sliding roof) to Ch. No. 315 220 883 from Ch. No. 316 000 001 to 310 2500 000 use to Ch. No. 282 175 363 877 071 A/209/117 877 217 A/ 411 877 241/363 877 259/313 877 305 A/ 306 A/355 B/356 B/363 A/364 A/365 A/ 366 A/369 A/373/375 B/117 877 433/ 311 867 169/313 877 453/465/ 117 877 481/495 A/499/363 877 505 A from Ch. No. 316 000 001 411 877 297	1 1 1	313, 314, 317, 318 317, 318
-	317 817 021 E	Roof (steel sliding roof) from Ch. No. 311 2000 001	1	317, 318
3	361 817 021 C	Roof to Ch. No. 360 2500 000	1	361, 362, 365, 366
-	361 817 021 F	Roof from Ch. No. 361 2000 001 (see Workshop Bulletin)	1	361, 362, 365, 366
-	363 817 021 C	Roof (steel sliding roof) to Ch. No. 360 2500 000 use 411 877 297	1	363, 364, 367, 368
-	363 817 021 F	Roof (steel sliding roof) from Ch. No. 361 2000 001 (see Workshop Bulletin)	1	363, 364, 367, 368
-	315 817 111 D	Roof from Ch. No. 311 2000 001	1	315, 316

4	311 817 133 C	Cross member, front – Roof use: to Ch. No. 315 220 883 311 857 511 from Ch. No. 316 000 001 to 317 500 000 111 857 561 B or 111 857 562 A	1	311, 312, 315, 316, 361, 362, 365, 366
-	313 817 133 A	Cross member, front – Roof to Ch. No. 316 060 000 use 311 857 511 to Ch. No. 315 220 883	1	313, 314, 317, 318, 363, 364, 367, 368
-	313 817 133 B	Cross member, front – Roof from Ch. No. 316 060 001 to 317 500 000	1	313, 314, 317, 318, 363, 364, 367, 368
-	313 817 133 C	Cross member, front – Roof from Ch. No. 318 000 001 use from Ch. No. 310 060 001 to 317 500 000 111 857 561 B or 111 857 562 A	1	313, 314, 317, 318, 363, 364, 367, 368
5	311 817 161	Cross member, rear – Roof to Ch. No. 315 220 883 from Ch. No. 316 000 001	1	311-318 315-318
6	311 817 161 A	Cross member, rear, upper – Roof from Ch. No. 316 000 001	1	311-314
7	311 817 171	Cross member, rear, lower – Roof from Ch. No. 316 000 001	1	311-314
8	361 817 209	Rain drip channel, front, left	1	361-368
-	361 817 210	Rain drip channel, front, right	1	361-368
9	311 817 211	Rain drip channel, left to Ch. No. 315 220 883 from Ch. No. 316 000 001 to 310 2500 000	1 1	311-318 315-318
10	311 817 211 A	Rain drip channel, left from Ch. No. 316 000 001	1	311-314
-	315 817 211	Rain drip channel, left from Ch. No. 311 2000 001	1	315-318
11	361 817 211	Rain drip channel, rear, left	1	361-368
-	311 817 212	Rain drip channel, right to Ch. No. 315 220 883 from Ch. No. 316 000 001 to 310 2500 000	1 1	311-318 315-318
-	311 817 212 A	Rain drip channel, right from Ch. No. 316 000 001	1	311-314
-	315 817 212	Rain drip channel, right from Ch. No. 311 2000 001	1	315-318
-	361 817 212	Rain drip channel, rear, right	1	361-368
12	361 817 357	Hinge mounting, left for rear door to Ch. No. 366 500 000	1	361-368

-	361 817 357 A	Hinge mounting, left for rear door from Ch. No. 367 000 001	1	361-368
-	361 817 358	Hinge mounting, right for rear door to Ch. No. 366 500 000	1	361-368
13	361 817 358 A	Hinge mounting, right for rear door from Ch. No. 367 000 001	1	361-368
14	361 817 363 A	Cross member upper part for rear door	1	361-368
15	361 817 367	Rain drip channel, rear, center	1	361-368
-	361 817 371	Bow - Roof, rear to Ch. No. 366 500 000	1	361-368
16	361 817 371 A	Bow - Roof, rear from Ch. No. 367 000 001	1	361-368
17	361 871 381 A	Cross member lower part for rear door to Ch. No. 360 2500 000	1	361-368
-	361 817 381 B	Cross member lower part for rear door from Ch. No. 361 2000 001	1	361-368

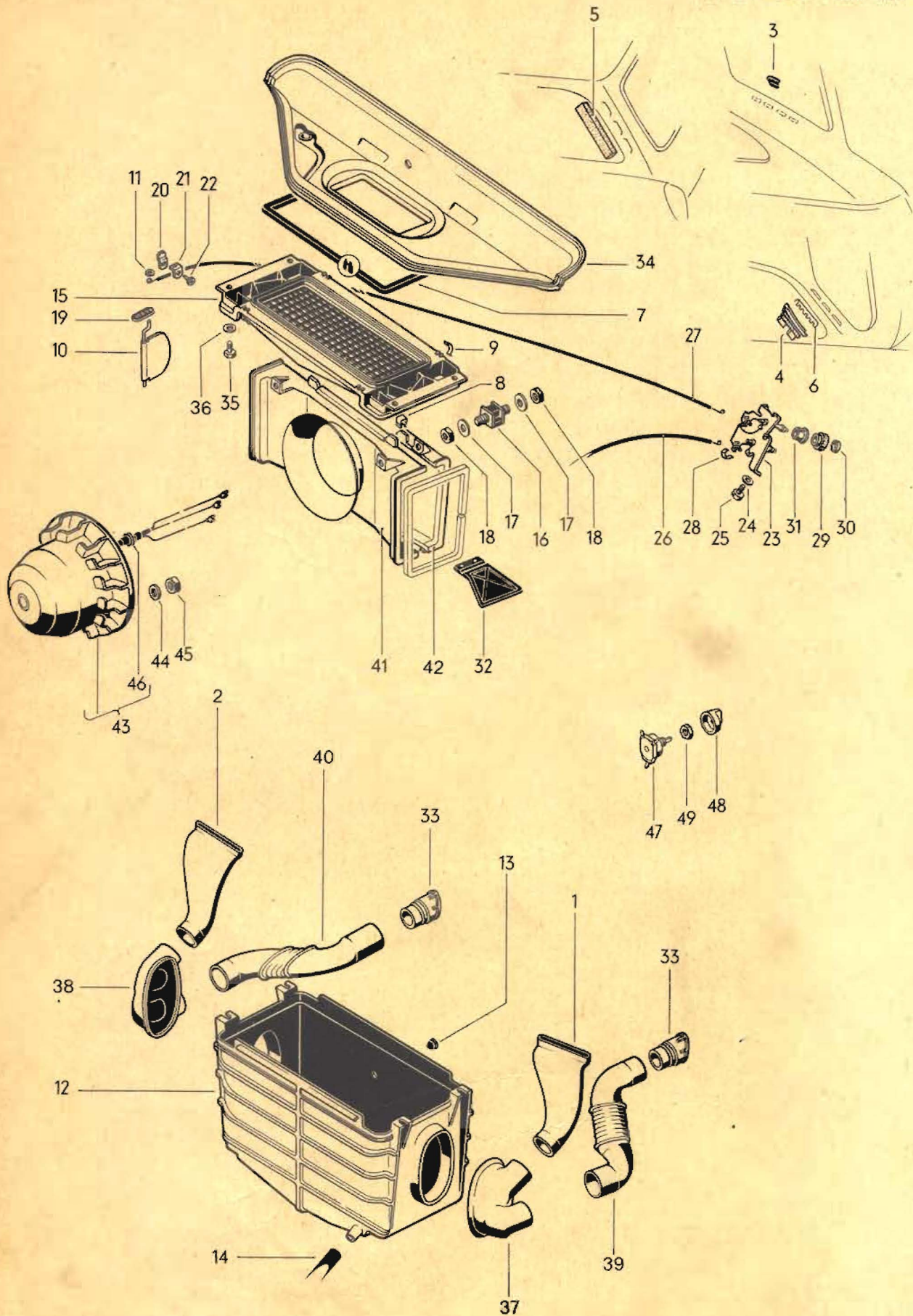

**MAIN GROUP 8**

**BODY**

Key	Part No.	Description	Qty.	Type and model
<b>FRESH AIR VENTILATION</b>				
<b>from Ch. No. 311 2000 001</b>				
<b>(to Ch. No. 310 2500 000</b>				
<b>see illustration 15)</b>				
1	311 819 071	Fresh air vent, left	1	
2	311 819 072	Fresh air vent, right	1	
3	311 819 465	Trim plate – Ventilation	8	311-314
4	315 819 471	Insert for air outlet, left	1	315-318
-	315 819 472	Insert for air outlet, right	1	315-318
5	361 819 479	Sound absorber for ventilation	2	361-368
6	311 867 493	Beading for vent trim plate	2	315-318
	8/70 .	581 cloud white		
7	311 819 519	Seal – Fresh air control box	1	
8	113 819 549	Clip – Fresh air duct	4	311-314, 361-364; M 121
9	311 819 549	Clip for fresh air control box	4	
10	311 819 551	Fresh air flap, left	1	
-	311 819 552	Fresh air flap, right	1	
11	311 259 197	Clamping plate	2	
12	311 819 565	Fresh air control box, lower part	1	
13	N 20 025 1	Plug A 12 x 1	1	315-318, 365-368
14	311 259 199 C	Water drain hose	1	
15	311 819 577	Fresh air control box, upper part	1	
16	411 819 757	Bonded rubber mounting	4	311-314, 361-364; M 121
17	N 11 695 2	Washer 6, 1	8	311-314, 361-364; M 121
18	N 11 006 2	Nut, hex. M 6	8	311-314, 361-364; M 121
19	311 819 579	Seal for fresh air flap opening in fresh air control box	2	
20	113 819 597	Clamping plate for cable on fresh air control box	2	
21	113 819 599	Retainer – Cable for fresh air control box	2	
22	N 13 968 1	Tapping screw fillister hd. B 4, 8 x 13	2	
23	311 819 611	Fresh air regulator	1	
24	N 12 226 2	Spring washer B 6	2	
25	N 14 138 9	Screw, fillister hd. A M 6 x 10	2	
26	311 819 619	Cable 500 mm, left for fresh air control	1	
27	311 819 620	Cable 300 mm, right for fresh air control	1	
28	311 259 325 B	Clip for fresh air control cables	2	

29	113 819 661 F	Knob - Fresh air regulator	2	
30	113 819 663	Cap - Knob	2	
31	113 819 607	Bush - Fresh air control knob on instrument panel	2	
32	311 819 675	Flap, left in fresh air duct	1	311-314, 361-364; M 121
-	311 819 676	Flap, right in fresh air duct	1	311-314, 361-364; M 121
33	311 819 703	Fresh air vent	2	
34	311 819 707	Deflector plate - Fresh air	1	
35	N 10 215 4	Bolt, hex. M6 x 15	4	
36	N 11 695 2	Washer 6, 1	4	
37	311 819 873	Branch piece, left, for fresh air		
38	311 819 874	Branch piece, right, for fresh air		
39	311 819 877	Connecting hose, left for fresh air vent	1	
40	311 819 878	Connecting hose, right for fresh air vent	1	
41	311 819 905	Fresh air duct, front part	1	311-314, 361-364; M 121
42	311 819 909	Fresh air duct, rear part	1	311-314, 361-364; M 121
43	311 959 113	Motor - Fresh air	1	311-314, 361-364; M 121
44	N 11 692 2	Washer 5, 1	4	311-314, 361-364; M 121
45	N 11 115 1	Nut, hex. BM 5	4	311-314, 361-364; M 121
46	311 971 913	Grommet 12.5 x 2	1	311-314, 361-364; M 121
47	113 959 511	Switch for fresh air fan	1	311-314, 361-364; M 121
48	113 959 513 A	Knob - Switch	1	311-314, 361-364; M 121
49	113 959 529	Nut, hex. M 10 x 1	1	311-314, 361-364; M 121



MAIN GROUP 8

BODY

Fender, Body to chassis  
Securing parts

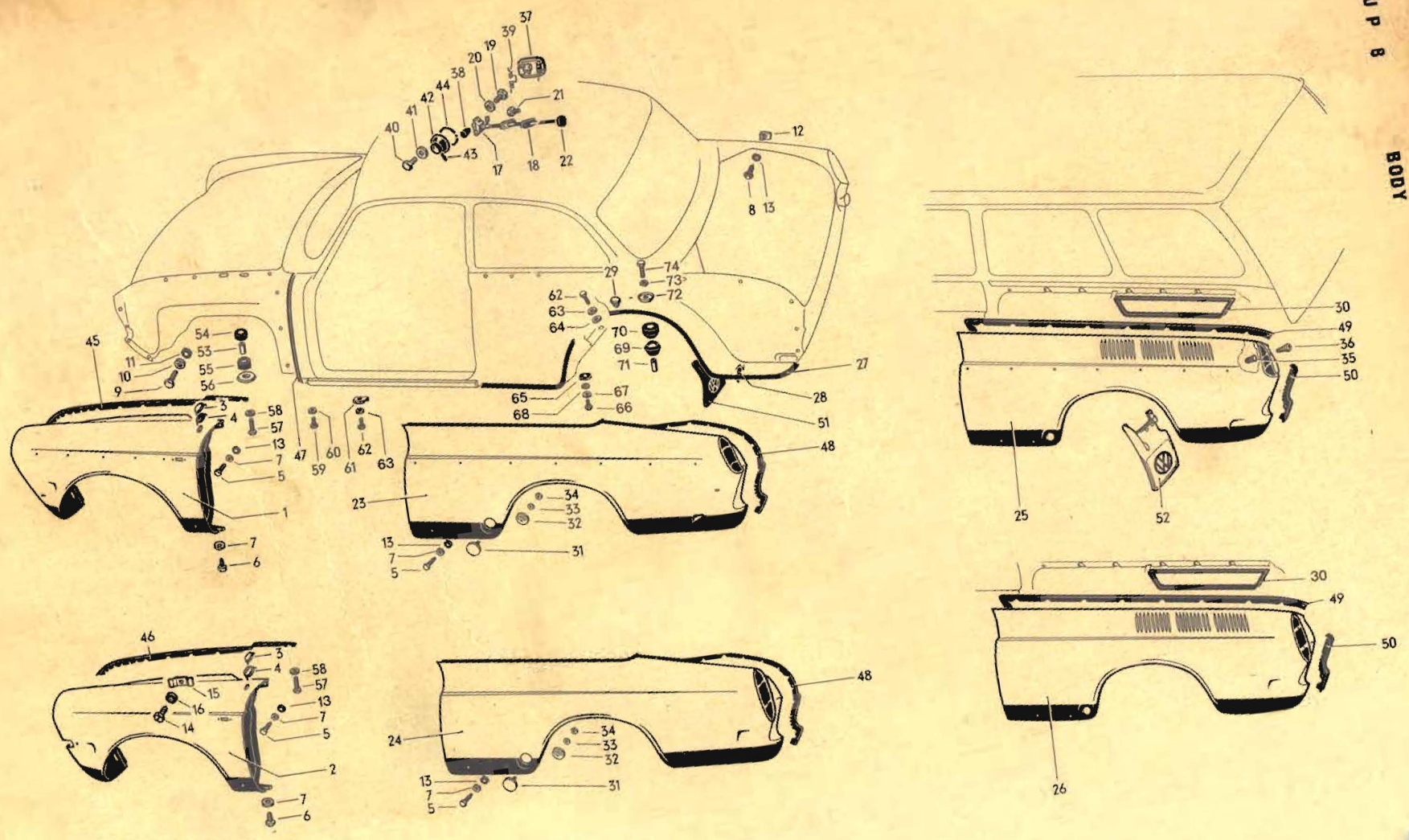

Illustration 42

Type 3

8-32





# Fender versions, front for Volkswagen Type 3

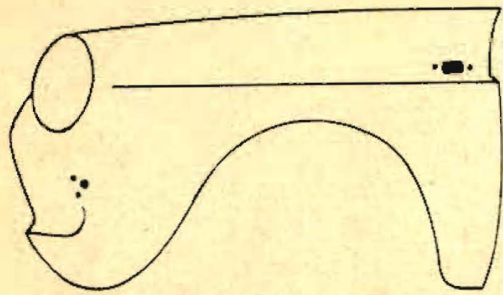

311 821 021  
symmetrically opposite 311 821 022

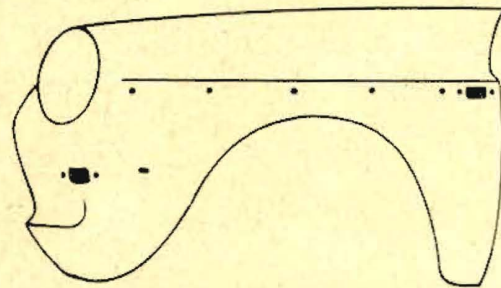

311 821 021 H  
symmetrically opposite 311 821 022 H  
symmetrically opposite with flap 311 821 032 G

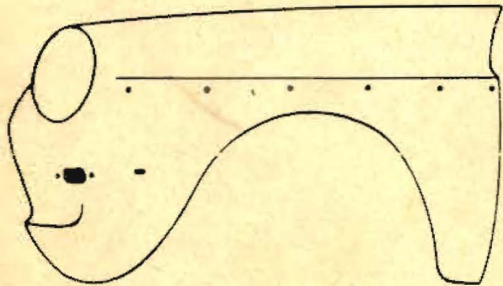

311 821 021 J  
symmetrically opposite 311 821 022 J  
symmetrically opposite with flap 311 821 032 E H

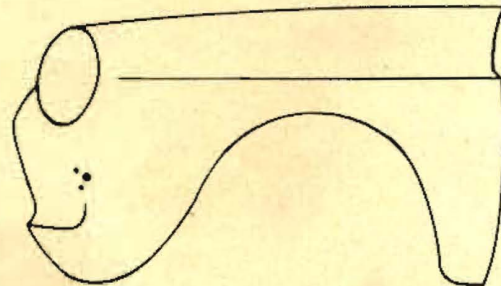

315 821 021 J  
symmetrically opposite 315 821 022 M  
symmetrically opposite with flap 315 821 032 K

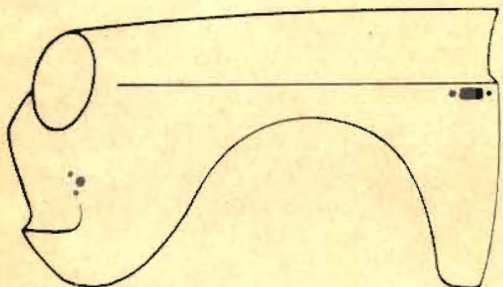

315 821 021 L  
symmetrically opposite 315 821 022 H  
symmetrically opposite with flap 315 821 032 L

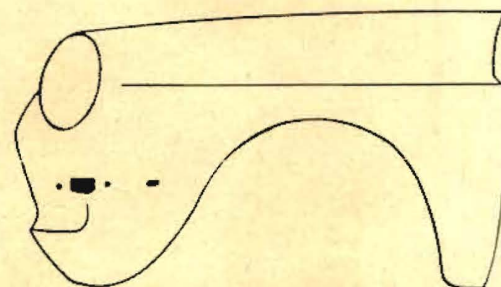

315 821 021 N  
symmetrically opposite with flap 315 821 032

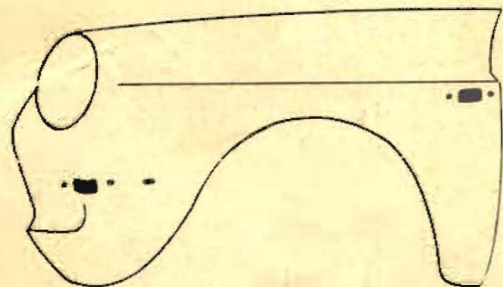

315 821 021 P  
symmetrically opposite with flap 315 821 032 A

**MAIN GROUP 8**

**BODY**

Key	Part No.	Description	Qty.	Type and model
<b>FENDER</b>				
-	311 821 021	Fender, front, left to Ch. No. 221 974	1	
1	311 821 021 H	Fender, front, left from Ch. No. 221 975 to 319 500 000	1	311-314, 361-364, M 234
-	311 821 021 J	*Fender, front, left (Sealed Beam headlamp) from Ch. No. 221 975 to 319 500 000 use for Model M 297 to Ch. No. 316 500 000 311 941 195 A/197 A; for Model M 237 from Ch. No. 316 000 001 to 318 103 144 311 941 195 A/197 A	1	M 297, M 237
-	315 821 021 J	Fender, front, left from Ch. No. 221 975 to 319 500 000 use: 311 941 195 A/197 A	1	315-318, 365-368, M 273, M 239, M 242, M 233
-	315 821 021 L	Fender, front, left (side flashing indicator) from Ch. No. 221 975 to 319 500 000	1	M 46
-	315 821 021 N	*Fender, front, left, without holes for molding and parking lamp from Ch. No. 310 2000 001	1	315-318, 365-368; M 233, M 239,
2	315 821 021 P	Fender, front, left, with holes for parking lamp without holes for molding from Ch. No. 310 2000 001	1	311-314, 361-364; M 46; M 234, M 237, M 273
-	311 821 022	Fender, front, right to Ch. No. 221 974	1	
-	311 821 022 H	Fender, front, right from Ch. No. 221 975 to 317 500 000	1	311-314, 361-364;
-	311 821 022 J	*Fender, front, right (Sealed Beam headlamp) from Ch. No. 221 975 to 317 500 000 use 311 941 195 A/197 A for Model 297 to Ch. No. 316 500 000; 311 941 195 A/197 A for Model M 237 from Ch. No. 316 000 001 to 317 500 000	1	M 297, M 237
-	315 821 022 H	Fender, front, right for side flashing indicator from Ch. No. 221 975 to 317 500 000	1	M 46

-	315 821 022 M	Fender, front, right from Ch. No. 221 975 to 317 500 000 use: 311 941 195 A/197 A	1	315-318, 365-368; M 273
-	311 821 032 G	Fender, front, right from Ch. No. 318 000 001 to 319 500 000 use from Ch. No. 318 000 001 to 318 500 000 311 821 421 B/241/245/111 823 535 D	1	311-314, 361-364; M 234
-	311 821 032 H	*Fender, front, right (Sealed Beam headlamp) from Ch. No. 318 00 001 to 319 500 000 use: from Ch. No. 318 000 001 to 318 500 000 311 821 421 B/241/245/111 823 535 D	1	M 297, M 237
-	315 821 032	*Fender, front, right, without holes for molding and parking lamp from Ch. No. 310 2000 001	1	315-318, 365-368; M 233, M 239
-	315 821 032 A	Fender, front, right, without molding holes, with holes for parking lamp from Ch. No. 310 2000 001	1	311-314, 361-364; M 46; M 234, M 237, M 273
-	315 821 032 K	*Fender, front, right from Ch. No. 318 000 001 to 319 500 000 use from Ch. No. 318 000 001 to 319 500 000 311 821 421 B/241/245/111 823 535 D	1	315-318, 365-368; M 273, M 239, M 233, M 242
-	315 821 032 L	Fender, front, right (side flashing indicator) from Ch. No. 318 000 001 to 319 500 000 use from Ch. No. 318 000 001 to 318 500 000 311 821 421 B/241/245/111 823 535 D	1	M 46
3	113 817 295 A	*Cover - Aerial opening from Ch. No. 317 000 001	1	
4	113 817 297 A	*Packing - Aerial opening from Ch. No. 317 000 001	1	
5	N 10 216 8	Bolt, hex. hd. M 6 x 18 for fender mounting	10 8	311-318 361-368
6	N 13 890 2	Tapping screw, hex. hd. B 6.3 x 13	2	
7	N 11 695 2	Washer 6.1	12 10	311-318 361-368
8	*311 821 143	Tapping screw, hex. hd. for fender mounting	44 38	311-314, 361-368 315-318
9	111 821 145	Bolt, hex. hd. M 8 x 18 from Ch. No. 319 076 517 to 319 190 521	4	
10	311 827 181	Washer 8.3 from Ch. No. 319 076 517 to 319 190 521	4	
11	311 705 761 A	Washer from Ch. No. 319 076 517 to 319 190 521	4	

12	*311 821 161	Speed nut for fender mounting	44 38	311-314, 361-368 315-318
-	311 821 171	*Bracket, upper for Sealed Beam headlight to Ch. No. 316 500 000	2	M 273, M 297
-	311 821 175	*Bracket, lower, left for Sealed Beam headlight to Ch. No. 316 500 000	2	M 273, M 297
-	311 821 176	*Bracket, lower right for Sealed Beam headlight to Ch. No. 316 500 000	2	M 273, M 297
13	*311 821 185	Washer for fender mounting	44 42	311-314, 361-368 315-318
14	N 10 240 4	Bolt, hex. hd. M 8 x 20 from Ch. No. 319 190 522	4	
15	*311 821 187	Plate for fender mounting from Ch. No. 319 190 522	4	
16	311 821 189	Rubber washer 7.5 x 26 for fender mounting from Ch. No. 319 190 522	4	
17	311 821 241	Release cable - Tank filler flap from Ch. No. 319 000 001	1	
18	311 821 245	Gasket for release cable - Tank filler flap from Ch. No. 319 000 001	1	
19	N 14 121 2	Screw, fillister hd. AM 4 x 6	2	
20	N 12 224 1	Spring washer B 4	2	
21	N 15 891 1	Tapping screw, fillister hd. A 4.9 x 16	2	
22	111 823 535 D	*Knob for release cable - Tank filler flap	1	
	8/68 -	043 grey-black		
23	315 821 301	Fender, rear, left to Ch. No. 315 220 883 from Ch. No. 221 975 to 319 500 000	1 1	311-314 315-318; M 234; M 237
24	315 821 301 J	*Fender, rear, left from Ch. No. 310 2000 001	1	315-318, M 234, M 237
25	365 821 301	*Fender, rear, left to Ch. No. 315 220 883 from Ch. No. 221 975 to 319 500 000 from Ch. No. 316 000 001 to 319 500 000	1 1 1	361-364 365-368; M 233; M 239; M 297 311-314, 361-364
26	365 821 301 C	Fender, rear, left from Ch. No. 310 2000 001	1	311-314, 361-368, M 233
-	315 821 302	*Fender, rear, right to Ch. No. 315 220 883 from Ch. No. 221 975 to 319 500 000	1 1	311-314 315-318
-	315 821 302 J	Fender, rear, right from Ch. No. 310 2000 001	1	315-318, M 234, M 237

-	365 821 302	*Fender, rear, right to Ch. No. 315 220 883	1	361-364
		from Ch. No. 221 975 to 319 500 000	1	365-368; M 233; M 239; M 2
		from Ch. No. 316 000 001 to 319 500 000	1	311-314; 361-364
-	365 821 302 C	Fender, rear, right from Ch. No. 310 2000 001	1	311-314, 361-368, M 233
27	311 821 331 C	Seal between fender and wheel housing	2	
28	111 941 187	Drain tube	2	311-318
29	N 20 022 3	Plug A 8 x 1	2	
-	361 821 333	Weatherstrip between fender and air passage to Ch. No. 365 220 883	2	361-368
30	361 821 333 A	Weatherstrip between fender and air passage from Ch. No. 316 000 001	2	311-314, 361-368
31	311 821 335 A	Inspection cover, outer for torsion bar	2	
32	111 805 673	*Inspection cover, inner for torsion bar	2	
33	N 12 225 1	Spring washer B 5	2	
34	N 11 005 2	Nut, hex. M 5	2	
-	361 821 355	Corner gasket - Air passage from Ch. No. 316 000 001	4	311-314, 361-368
35	*311 821 399	Grommet - Tapping screw	2	311-314
36	N 13 957 3	Tapping screw BZ 3.5 x 9.5	2	311-314, 361-368
-	311 821 421 A	Flap for fuel filler from Ch. No. 318 000 001 to 318 500 000	1	
37	311 821 421 B	Flap for fuel filler from Ch. No. 319 000 001	1	
38	111 857 145 A	*Rubber stop - Flap	2	
-	111 809 931	*Spring to Ch. No. 318 500 000	1	
39	111 809 931 A	*Spring from Ch. No. 319 000 001	1	
40	N 10 206 1	Bolt, hex. hd. M 5 x 6	2	
41	111 837 939	*Cup washer 5.2 x 12.5	2	
42	311 821 443 A	Collar for fuel filler neck from Ch. No. 318 000 001	1	
43	311 821 445	Drain hose from Ch. No. 318 000 001	1	
44	311 821 447	Support ring - Collar from Ch. No. 318 000 001	1	

to Ch. No. 319 500 000

- 041 black  
(vehicle color: black)
- 087 pearl white  
(vehicle color: pearl white)
- 282 lotus white  
(vehicle color: lotus white)
- 360 sea blue  
(vehicle color: sea blue)
- 390 gulf blue  
(vehicle color: gulf blue)
- 456 ruby red  
(vehicle color: ruby red)
- 469 anthracite  
(vehicle color: anthracite)
- 511 birch green  
(vehicle color: birch green)
- 512 velvet green  
(vehicle color: velvet green)
- 539 Baltic blue  
(vehicle color: Baltic blue)
- 563 safari beige  
(vehicle color: safari beige)
- 568 sea sand  
(vehicle color: sea sand)
- 575 nutria brown  
(vehicle color: nutria brown)
- 610 Delta green  
(vehicle color: Delta green)
- 620 savanna beige  
(vehicle color: savanna beige)
- 630 cobalt blue  
(vehicle color: cobalt blue)
- 633 VW blue  
(vehicle color: VW blue)
- 650 Granada red  
(vehicle color: Granada red)
- 30 A royal red  
(vehicle color: royal red)
- 50 B diamond blue  
(vehicle color: diamond blue)
- 50 F regatta blue  
(vehicle color: regatta blue)
- 60 B Peru green  
(vehicle color: Peru green)
- 66 B deep sea green  
(vehicle color: deep sea green)

46 311 821 705 B

- 70 F chinchilla  
(vehicle color: chinchilla)
- 90 C toga white  
(vehicle color: toga white)
- Beading – Front fender, left 1  
from Ch. No. 310 2000 001
- 20 D clementine  
(vehicle color: clementine)
- 041 black  
(vehicle color: black)
- 50 B diamond blue  
(vehicle color: diamond blue)
- 60 D elm green  
(vehicle color: elm green)
- 66 B deep sea green  
(vehicle color: deep sea green)
- 70 F chinchilla  
(vehicle color: chinchilla)
- 90 D pastel white  
(vehicle color: pastel white)
- 620 savanna beige  
(vehicle color: savanna beige)
- 630 cobalt blue  
(vehicle color: cobalt blue)
- 31V colorado red  
(vehicle color: colorado metallic)
- 86V atlas brown  
(vehicle color: brown metallic)
- 96V silver 70  
(vehicle color: silver metallic)
- 12D Shantung yellow  
(vehicle color: Shantung yellow)
- 31F Iberian red  
(vehicle color: Iberian red)
- 50D Sapphire blue  
(vehicle color: Sapphire blue)
- 54D Marina blue  
(vehicle color: Marina blue)
- 91D kansas beige  
(vehicle color: kansas beige)
- 885 Gemini blue  
(vehicle color: Gemini metallic)
- 10B texas yellow  
(vehicle color: texas yellow)
- 20B brilliant orange  
(vehicle color: brilliant orange)
- 30B kasan red  
(vehicle color: kasan red)



- 51B gentian blue  
(vehicle color: gentian blue)
- 60S turquoise 72  
(vehicle color: turquoise metallic)
- 61B sumatra green  
(vehicle color: sumatra green)

- 311 821 706 A

Beading - Front fender, right  
to Ch. No. 319 500 000

1

- 041 black  
(vehicle color: black)
- 087 pearl white  
(vehicle color: pearl white)
- 282 lotus white  
(vehicle color: lotus white)
- 360 sea blue  
(vehicle color: sea blue)
- 390 gulf blue  
(vehicle color: gulf blue)
- 456 ruby red  
(vehicle color: ruby red)
- 469 anthracite  
(vehicle color: anthracite)
- 511 birch green  
(vehicle color: birch green)
- 512 velvet green  
(vehicle color: velvet green)
- 539 Baltic blue  
(vehicle color: Baltic blue)
- 563 safari beige  
(vehicle color: safari beige)
- 568 sea sand  
(vehicle color: sea sand)
- 575 nutria brown  
(vehicle color: nutria brown)
- 610 Delta green  
(vehicle color: Delta green)
- 620 savanna beige  
(vehicle color: savanna beige)
- 630 cobalt blue  
(vehicle color: cobalt blue)
- 633 VW blue  
(vehicle color: VW blue)
- 650 Granada red  
(vehicle color: Granada red)
- 30 A royal red  
(vehicle color: royal red)
- 50 B diamond blue  
(vehicle color: diamond blue)

50 F regatta blue  
 (vehicle color: regatta blue)  
 60 B Peru green  
 (vehicle color: Peru green)  
 66 B deep sea green  
 (vehicle color: deep sea green)  
 70 F chinchilla  
 (vehicle color: chinchilla)  
 90 C toga white  
 (vehicle color: toga white)  
 311 821 706 B Beading – Front fender, right 1  
 from Ch. No. 310 2000 001  
 20 D clementine  
 (vehicle color: clementine)  
 041 black  
 (vehicle color: black)  
 50 B diamond blue  
 (vehicle color: diamond blue)  
 60 D elm green  
 (vehicle color: elm green)  
 66 B deep sea green  
 (vehicle color: deep sea green)  
 70 F chinchilla  
 (vehicle color: chinchilla)  
 90 D pastel white  
 (vehicle color: pastel white)  
 620 savanna beige  
 (vehicle color: savanna beige)  
 630 cobalt blue  
 (vehicle color: cobalt blue)  
 31V colorado red  
 (vehicle color: colorado metallic royal red)  
 86V atlas brown  
 (vehicle color: brown metallic)  
 96V silver 70  
 (vehicle color: silver metallic)  
 12D Shantung yellow  
 (vehicle color: Shantung yellow)  
 31F Iberian red  
 (vehicle color: Iberian red)  
 50D Sapphire blue  
 (vehicle color: Sapphire blue)  
 54D Marina blue  
 (vehicle color: Marina blue)  
 91D kansas beige  
 (vehicle color: kansas beige)

		885 Gemini blue (vehicle color: Gemini metallic)		
		10B texas yellow (vehicle color: texas yellow)		
		20B brilliant orange (vehicle color: brilliant orange)		
		30B kasan red (vehicle color: kasan red)		
		51B gentian blue (vehicle color: gentian blue)		
		60S turquoise 72 (vehicle color: turquoise metallic)		
		61B sumatra green (vehicle color: sumatra green)		
47	D 19	Sealing strip for front fender		X
48	311 821 715 A	Beading - Rear fender, left to Ch. No. 315 220 883 from Ch. No. 316 000 001	1 1	311-318 315-318
		041 black (vehicle color: black)		
		087 pearl white (vehicle color: pearl white)		
		282 lotus white (vehicle color: lotus white)		
		360 sea blue (vehicle color: sea blue)		
		390 gulf blue (vehicle color: gulf blue)		
		456 ruby red (vehicle color: ruby red)		
		469 anthracite (vehicle color: anthracite)		
		511 birch green (vehicle color: birch green)		
		512 velvet green (vehicle color: velvet green)		
		539 Baltic blue (vehicle color: Baltic blue)		
		563 safari beige (vehicle color: safari beige)		
		568 sea sand (vehicle color: sea sand)		
		575 nutria brown (vehicle color: nutria brown)		
		610 Delta green (vehicle color: Delta green)		

- 620 savanna beige  
(vehicle color: savanna beige)
- 630 cobalt blue  
(vehicle color: cobalt blue)
- 633 VW blue  
(vehicle color: VW blue)
- 650 Granada red  
(vehicle color: Granada red)
- 20 D clementine  
(vehicle color: clementine)
- 50 B diamond blue  
(vehicle color: diamond blue)
- 50 F regatta blue  
(vehicle color: regatta blue)
- 60 B Peru green  
(vehicle color: Peru green)
- 60 D elm green  
(vehicle color: elm green)
- 66 B deep sea green  
(vehicle color: deep sea green)
- 70 F chinchilla  
(vehicle color: chinchilla)
- 90 C toga white  
(vehicle color: toga white)
- 90 D pastel white  
(vehicle color: pastel white)
- 31V colorado red  
(vehicle color: colorado metallic royal red)
- 86V atlas brown  
(vehicle color: brown metallic)
- 96V silver 70  
(vehicle color: silver metallic)
- 12D Shantung yellow  
(vehicle color: Shantung yellow)
- 31F Iberian red  
(vehicle color: Iberian red)
- 50D Sapphire blue  
(vehicle color: Sapphire blue)
- 54D Marina blue  
(vehicle color: Marina blue)
- 91D kansas beige  
(vehicle color: kansas beige)
- 885 Gemini blue  
(vehicle color: Gemini metallic)
- 10B texas yellow  
(vehicle color: texas yellow)
- 20B brilliant orange  
(vehicle color: brilliant orange)

- 30B kasan red  
(vehicle color: kasan red)
- 51B gentian blue  
(vehicle color: gentian blue)
- 60S turquoise 72  
(vehicle color: turquoise metallic)
- 61B sumatra green  
(vehicle color: sumatra green)

49 361 821 715 A

Beading - Rear fender, left

to Ch. No. 315 220 883	1	361-368
from Ch. No. 316 000 001	1	311-314, 361-368

- 041 black  
(vehicle color: black)
- 087 pearl white  
(vehicle color: pearl white)
- 282 lotus white  
(vehicle color: lotus white)
- 360 sea blue  
(vehicle color: sea blue)
- 390 gulf blue  
(vehicle color: gulf blue)
- 456 ruby red  
(vehicle color: ruby red)
- 469 anthracite  
(vehicle color: anthracite)
- 511 birch green  
(vehicle color: birch green)
- 512 velvet green  
(vehicle color: velvet green)
- 539 Baltic blue  
(vehicle color: Baltic blue)
- 563 safari beige  
(vehicle color: safari beige)
- 568 sea sand  
(vehicle color: sea sand)
- 575 nutria brown  
(vehicle color: nutria brown)
- 610 Delta green  
(vehicle color: Delta green)
- 620 savanna beige  
(vehicle color: savanna beige)
- 630 cobalt blue  
(vehicle color: cobalt blue)
- 633 VW blue  
(vehicle color: VW blue)
- 650 Granada red  
(vehicle color: Granada red)

- 20 D clementine  
(vehicle color: clementine)
- 30 A royal red  
(vehicle color: royal red)
- 50 B diamond blue  
(vehicle color: diamond blue)
- 50 F regatta blue  
(vehicle color: regatta blue)
- 60 B Peru green  
(vehicle color: Peru green)
- 60 D elm green  
(vehicle color: elm green)
- 66 B deep sea green  
(vehicle color: deep sea green)
- 70 F chinchilla  
(vehicle color: chinchilla)
- 90 C toga white  
(vehicle color: toga white)
- 90 D pastel white  
(vehicle color: pastel white)
- 31V colorado red  
(vehicle color: colorado metallic)
- 86V atlas brown  
(vehicle color: brown metallic)
- 96V silver 70  
(vehicle color: silver metallic)
- 12D Shantung yellow  
(vehicle color: Shantung yellow)
- 31F Iberian red  
(vehicle color: Iberian red)
- 50D Sapphire blue  
(vehicle color: Sapphire blue)
- 54D Marina blue  
(vehicle color: Marina blue)
- 91D kansas beige  
(vehicle color: kansas beige:)
- 885 Gemini blue  
(vehicle color: Gemini metallic)
- 10B texas yellow  
(vehicle color: texas yellow)
- 20B brilliant orange  
(vehicle color: brilliant orange)
- 30B kasan red  
(vehicle color: kasan red)
- 51B gentian blue  
(vehicle color: gentian blue)

60S turquoise 72  
(vehicle color: turquoise metallic)

61B sumatra green  
(vehicle color: sumatra green)

- 311 821 716 A

Beading - Rear fender, right

to Ch. No. 315 220 883 1 311-318

from Ch. No. 316 000 001 1 315-318

041 black  
(vehicle color: black)

087 pearl white  
(vehicle color: pearl white)

282 lotus white  
(vehicle color: lotus white)

360 sea blue  
(vehicle color: sea blue)

390 gulf blue  
(vehicle color: gulf blue)

456 ruby red  
(vehicle color: ruby red)

469 anthracite  
(vehicle color: anthracite)

511 birch green  
(vehicle color: birch green)

512 velvet green  
(vehicle color: velvet green)

539 Baltic blue  
(vehicle color: Baltic blue)

563 safari beige  
(vehicle color: safari beige)

568 sea sand  
(vehicle color: sea sand)

575 nutria brown  
(vehicle color: nutria brown)

610 Delta green  
(vehicle color: Delta green)

620 savanna beige  
(vehicle color: savanna beige)

630 cobalt blue  
(vehicle color: cobalt blue)

633 VW blue  
(vehicle color: VW blue)

650 Granada red  
(vehicle color: Granada red)

20 D clementine  
(vehicle color: clementine)

50 B diamond blue  
(vehicle color: diamond blue)

- 50 F regatta blue  
(vehicle color: regatta blue)
- 60 B Peru green  
(vehicle color: Peru green)
- 60 D elm green  
(vehicle color: elm green)
- 66 B deep sea green  
(vehicle color: deep sea green)
- 70 F chinchilla  
(vehicle color: chinchilla)
- 90 C toga white  
(vehicle color: toga white)
- 90 D pastel white  
(vehicle color: pastel white)
- 31V colorado red  
(vehicle color: colorado metallic royal red)
- 86V atlas brown  
(vehicle color: brown metallic)
- 96V silver 70  
(vehicle color: silver metallic)
- 12D Shantung yellow  
(vehicle color: Shantung yellow)
- 31F Iberian red  
(vehicle color: Iberian red)
- 50D Sapphire blue  
(vehicle color: Sapphire blue)
- 54D Marina blue  
(vehicle color: Marina blue)
- 91D kansas beige  
(vehicle color: kansas beige)
- 885 Gemini blue  
(vehicle color: Gemini metallic)
- 10B texas yellow  
(vehicle color: texas yellow)
- 20B brilliant orange  
(vehicle color: brilliant orange)
- 30B kasan red  
(vehicle color: kasan red)
- 51B gentian blue  
(vehicle color: gentian blue)
- 60S turquoise 72  
(vehicle color: turquoise metallic)
- 61B sumatra green  
(vehicle color: sumatra green)



Beading - Rear fender, right

to Ch. No. 315 220 883	1	361-368
from Ch. No. 316 000 001	1	311-314, 361-368
041 black		
(vehicle color: black)		
087 pearl white		
(vehicle color: pearl white)		
282 lotus white		
(vehicle color: lotus white)		
360 sea blue		
(vehicle color: sea blue)		
390 gulf blue		
(vehicle color: gulf blue)		
456 ruby red		
(vehicle color: ruby red)		
469 anthracite		
(vehicle color: anthracite)		
511 birch green		
(vehicle color: birch green)		
512 velvet green		
(vehicle color: velvet green)		
539 Baltic blue		
(vehicle color: Baltic blue)		
563 safari beige		
(vehicle color: safari beige)		
568 sea sand		
(vehicle color: sea sand)		
575 nutria brown		
(vehicle color: nutria brown)		
610 Delta green		
(vehicle color: Delta green)		
620 savanna beige		
(vehicle color: savanna beige)		
630 cobalt blue		
(vehicle color: cobalt blue)		
633 VW blue		
(vehicle color: VW blue)		
650 Granada red		
(vehicle color: Granada red)		
20 D clementine		
(vehicle color: clementine)		
50 B diamond blue		
(vehicle color: diamond blue)		
50 F regatta blue		
(vehicle color: regatta blue)		

- 60 B Peru green  
(vehicle color: Peru green)
- 60 D elm green  
(vehicle color: elm green)
- 66 B deep sea green  
(vehicle color: deep sea green)
- 70 F chinchilla  
(vehicle color: chinchilla)
- 90 C toga white  
(vehicle color: toga white)
- 90 D pastel white  
(vehicle color: pastel white)
- 31V colorado red  
(vehicle color: colorado metallic royal red)
- 86V atlas brown  
(vehicle color: brown metallic)
- 96V silver 70  
(vehicle color: silver metallic)
- 12D Shantung yellow  
(vehicle color: Shantung yellow)
- 31F Iberian red  
(vehicle color: Iberian red)
- 50D Sapphire blue  
(vehicle color: Sapphire blue)
- 54D Marina blue  
(vehicle color: Marina blue)
- 91D kansas beige  
(vehicle color: kansas beige)
- 885 Gemini blue  
(vehicle color: Gemini metallic)
- 10B texas yellow  
(vehicle color: texas yellow)
- 20B brilliant orange  
(vehicle color: brilliant orange)
- 30B kasan red  
(vehicle color: kasan red)
- 51B gentian blue  
(vehicle color: gentian blue)
- 60S turquoise 72  
(vehicle color: turquoise metallic)
- 61B sumatra green  
(vehicle color: sumatra green)

50 361 821 781 A

Beading

for rear apron

to Ch. No. 315 220 883

2 361-368

from Ch. No. 316 000 001

2 311-314, 361-368

041 black

(vehicle color: black)

- 087 pearl white  
(vehicle color: pearl white)
- 282 lotus white  
(vehicle color: lotus white)
- 360 sea blue  
(vehicle color: sea blue)
- 390 gulf blue  
(vehicle color: gulf blue)
- 456 ruby red  
(vehicle color: ruby red)
- 469 anthracite  
(vehicle color: anthracite)
- 511 birch green  
(vehicle color: birch green)
- 512 velvet green  
(vehicle color: velvet green)
- 539 Baltic blue  
(vehicle color: Baltic blue)
- 563 safari beige  
(vehicle color: safari beige)
- 568 sea sand  
(vehicle color: sea sand)
- 575 nutria brown  
(vehicle color: nutria brown)
- 610 Delta green  
(vehicle color: Delta green)
- 620 savanna beige  
(vehicle color: savanna beige)
- 630 cobalt blue  
(vehicle color: cobalt blue)
- 633 VW blue  
(vehicle color: VW blue)
- 650 Granada red  
(vehicle color: Granada red)
- 20 D clementine  
(vehicle color: clementine)
- 50 B diamond blue  
(vehicle color: diamond blue)
- 50 F regatta blue  
(vehicle color: regatta blue)
- 60 B Peru green  
(vehicle color: Peru green)
- 60 D elm green  
(vehicle color: elm green)
- 66 B deep sea green  
(vehicle color: deep sea green)
- 70 F chinchilla  
(vehicle color: chinchilla)

	90 C	toga white (vehicle color: toga white)		
	90 D	pastel white (vehicle color: pastel white)		
	31V	colorado red (vehicle color: colorado metallic royal red)		
	86V	atlas brown (vehicle color: brown metallic)		
	96V	silver 70 (vehicle color: silver metallic)		
	12D	Shantung yellow (vehicle color: Shantung yellow)		
	31F	Iberian red (vehicle color: Iberian red)		
	50D	Sapphire blue (vehicle color: Sapphire blue)		
	54D	Marina blue (vehicle color: Marina blue)		
	91D	kansas beige (vehicle color: kansas beige)		
	885	Gemini blue (vehicle color: Gemini metallic)		
	10B	texas yellow (vehicle color: texas yellow)		
	20B	brilliant orange (vehicle color: brilliant orange)		
	30B	kasan red (vehicle color: kasan red)		
	51B	gantian blue (vehicle color: gantian blue)		
	60S	turquoise 72 (vehicle color: turquoise metallic)		
	61B	sumatra green (vehicle color: sumatra green)		
51	311 821 805 D	1 set of mud flaps black 360 mm with brackets to Ch. No. 311 2108 457	1	M 290
52	311 821 805 E	1 set of mud flaps white 360 mm with brackets	1	
(51)	311 821 811 D	Mud flap left with bracket, black 360 mm to Ch. No. 311 2108 457	1	M 290
(52)	361 821 811 D	Mud flap left with bracket, 410 mm from Ch. No. 311 2108 458	1	M 74
(52)	311 821 811 E	Mud flap left with bracket, white 360 mm	1	

(51)	311 821 812 D	Mud flap right with bracket, black 360 mm to Ch. No. 311 2108 457	1	M 290
(52)	361 821 812 D	Mud flap right with bracket, 410 mm from Ch. No. 311 2108 458	1	M 74
(52)	311 821 812 E	Mud flap right with bracket, white 360 mm	1	

**BODY TO CHASSIS  
SECURING PARTS**

53	311 899 105 A	*Distance tube – Body mounting on front axle bracket	2	
54	311 899 115	*Rubber bush, upper – Body mounting on front axle bracket	2	
55	311 899 117	*Rubber bush, lower – Body mounting on front axle bracket	2	
56	311 705 695	Washer – Body mounting on front axle bracket	2	
57	N 10 465 1	Bolt, hex. hd. M 10 x 65	2	
58	N 11 527 1	Washer A 10.5	2	
59	N 10 450 1	Bolt, hex. hd. M 10 x 50 for body and frame, front	4	
60	211 707 189	*Spring washer 10.5 x 26	4	
61	311 899 131	*Reinforcement – Body mounting on floor plate	18	
62	111 899 145	*Bolt, hex. hd. M 8 x 27 – Body mounting on floor plate and rear cross member	24	
63	N 12 228 2	Spring washer B 8	24	
64	N 11 670 1	Washer 8.1	6	
65	311 899 135 A	*Rubber pad between body and frame (rear)	2	
66	N 10 254 6	Bolt, hex. hd. M 10 x 25	2	
67	N 12 011 2	Lock washer A 10	2	
68	311 899 165	*Washer 10.2 between body and frame (rear)	2	
69	311 899 155	*Rubber bush, lower – Body mounting on sub-frame	2	
70	311 899 157	*Rubber bush, upper for body mounting on sub-frame	2	
–	311 899 159	*Spacer – Body mounting on sub-frame	2	
–	311 899 161 A	*Spacer sleeve 37.5 mm for body mounting on sub-frame from Ch. No. 317 500 000	2	
71	311 899 161 B	*Spacer sleeve 40 mm for body mounting on sub-frame to Ch. No. 318 000 001	2	
72	311 899 163	*Spacer – Body mounting on sub-frame	2	

73	311 899 165	*Washer 10.2 – Body mounting on sub-frame	2
-	N 10 465 1	Bolt, hex. hd. M 10 x 65 from Ch. No. 317 500 000	2
74	N 10 470 1	Bolt, hex. hd. M 10 x 70 from Ch. No. 318 000 001	2



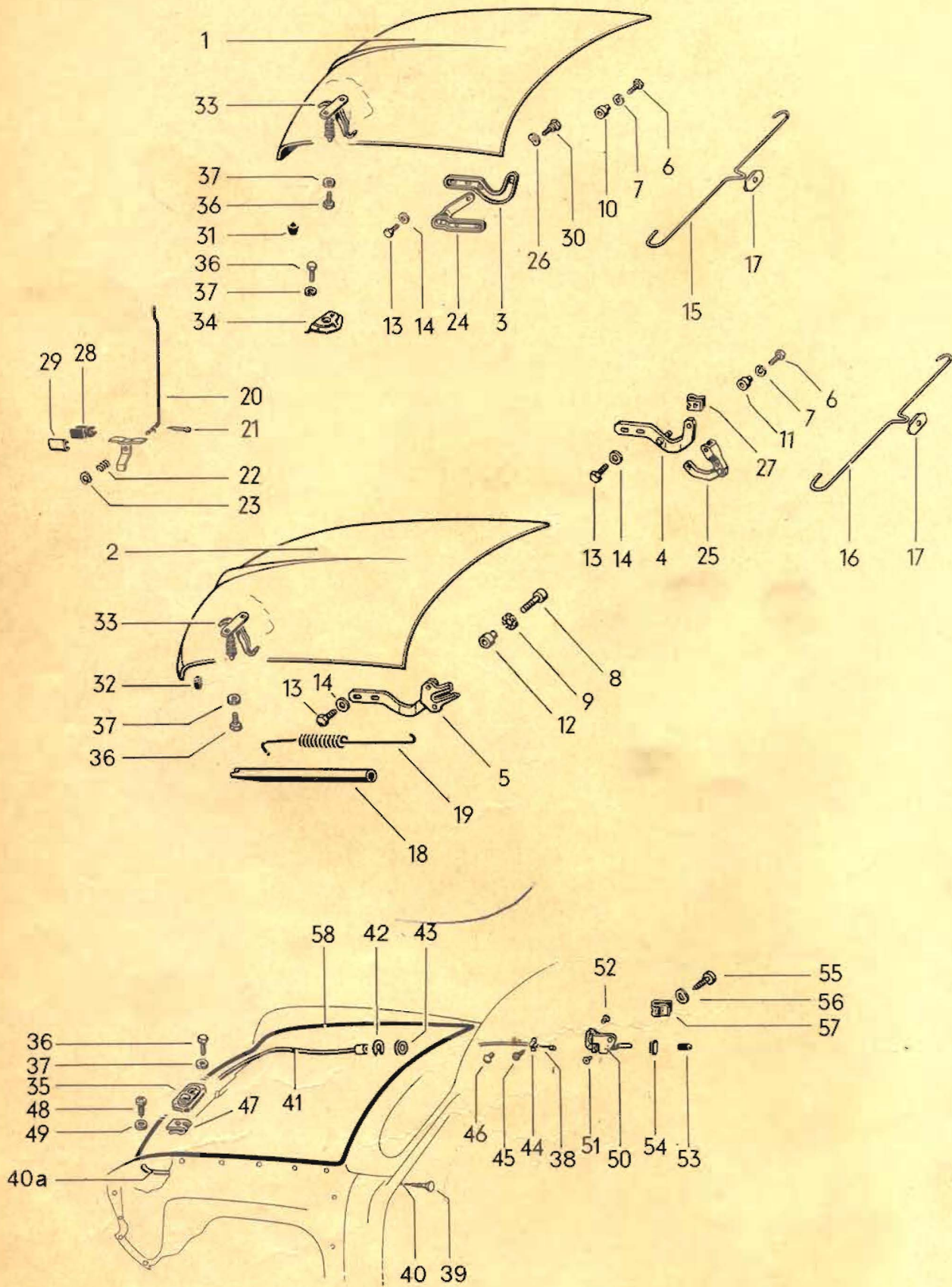



**MAIN GROUP 8**

**BODY**

Key	Part No.	Description	Qty.	Type and model
<b>FRONT HOOD</b>				
1	315 823 031	Hood, front to Ch. No. 319 500 000	1	
2	311 823 031 C	Hood, front from Ch. No. 310 2000 001	1	
3	311 823 301	Hood hinge, front left to Ch. No. 319 500 000	1	
4	311 823 301 A	Hood hinge, front left from Ch. No. 310 2000 001 to 310 2500 000	1	
5	311 823 301 B	Hood hinge, front left from Ch. No. 311 2000 001	1	
-	311 823 302	Hood hinge, front right to Ch. No. 319 500 000	1	
-	311 823 302 A	Hood hinge, front right from Ch. No. 310 2000 001 to 310 2500 000	1	
-	311 823 302 B	Hood hinge, front right from Ch. No. 311 2000 001	1	
6	N 10 240 4	Bolt, hex. hd. M 8 x 20 to Ch. No. 310 2500 000	2	
7	111 821 149 A	Spring washer 8.1 x 22 to Ch. No. 310 2500 000	2	
8	N 14 713 2	Screw, cheese hd. M 8 x 35 from Ch. No. 311 2000 001	2	
9	N 15 371 1	Lock washer 8.4 from Ch. No. 311 2000 001	2	
10	311 823 315	Bush 18/21 mm dia. for hood hinge to Ch. No. 319 500 000	2	
11	311 823 315 A	Bush 31 x 17 x 9 mm dia for hood hinge from Ch. No. 310 2000 001 to 310 2500 000	2	
12	311 823 315 B	Bush 13 x 17 x 20.8 mm dia. for hood hinge from Ch. No. 311 2000 001	2	
13	N 10 238 7	Bolt, hex. hd. M 8 x 15	4	
14	111 821 149 A	Spring washer 8.1 x 22	4	
15	311 823 353 A	Torsion bar - Front hood to Ch. No. 319 500 000	1	
16	311 823 353 B	Torsion bar - Front hood from Ch. No. 310 2000 001 to 310 2500 000	1	
17	111 899 131	Packing - Torsion bar to Ch. No. 310 2500 000	X	
18	311 823 355	Protective tube for hood spring from Ch. No. 311 2000 001	2	

19	311 823 359	Spring for front hood from Ch. No. 311 2000 001	2	
20	315 823 363	Hinge stay - Front hood from Ch. No. 221 975 to 483 592	1	315-318, 365-368
21	N 12 522 1	Cotter pin 2 x 22	1	315-318, 365-368
22	315 823 367	Spring - Hood support from Ch. No. 221 975 to 483 592	1	315-318, 365-368
23	N 12 435 1	Lock washer 5	1	315-318, 365-368
24	311 823 371	Hinge stay - Front hood to Ch. No. 319 500 000	2	
25	361 827 361	Hinge stay - Front hood from Ch. No. 310 2000 001 to 310 2500 000	2	
26	311 823 385	Spring washer 8.6 x 15 to Ch. No. 319 500 000	2	
27	N 12 646 1	Spring washer 6 from Ch. No. 310 2000 001 to 310 2500 000	2	
28	315 823 395	Rubber retainer for hood support from Ch. No. 221 975 to 483 592	1	315-318, 365-368
29		Channel - Rubber retainer make from 111 813 169	1	315-318, 365-368
30	311 823 399	Bolt, hex. hd. - Front hood hinge stay to Ch. No. 319 500 000	2	
31	311 823 499	Rubber stop - Front hood to Ch. No. 209 892	2	311-314, 361-364
32	311 823 499 A	Rubber stop - Front hood from Ch. No. 209 893	2	
33	411 823 507	Lock pin carrier for front hood	1	
-	311 823 509 C	Lock on front panel to Ch. No. 318 500 000	1	
34	311 823 509 D	Lock on front panel from Ch. No. 319 000 001 to 319 500 000	1	
35	411 823 509	Lock on front panel from Ch. No. 310 2000 001 to 310 2500 000 from Ch. No. 311 2000 001	1 1	311, 313, 315, 317, 361, 363, 365, 367
-	312 823 509	Lock on front panel from Ch. No. 311 2000 001	1	312, 314, 316, 318, 362, 364, 366, 368
36	N 10 210 7	Bolt, hex. hd. M 6 x 10K	6	
37	211 805 243	Spring washer 6.5 x 17	6	
-	311 823 523	Return spring for front panel lock 311 823 509 A	1	

-	343 823 531 A	Cable - Front hood lock (length 1690 mm - 66 17/32 in.) to Ch. No. 317 500 000	1	
38	<u>412 823 531</u>	Cable - Front hood lock from Ch. No. 319 000 001	1	
39	111 823 533	Knob with spring for lock cable, front from Ch. No. 318 000 001 to 318 500 000	1	
40	311 823 543 B	Cable - Front hood lock (length 1600 mm - 63 in.) without knob from Ch. No. 318 000 001 to 318 500 000	1	
40a	412 823 557 A	Conduit tube 4/6 mm dia. (length 2940 mm - 115 3/4 in.) to Ch. No. 310 2500 000	1	
41	311 823 557 M	Conduit tube 4/6 mm dia. (length 1790 mm - 70 15/32 in.) from Ch. No. 311 2000 001 to 311 2500 000	1	
-	411 823 557 C	Conduit tube 4/6 mm dia. (length 2160 mm - 85 1/32 in.) from Ch. No. 312 2000 001	1	
42	411 823 577	*Lock washer from Ch. No. 311 2000 001	1	
43	111 971 911	Grommet 16.5 x 4 from Ch. No. 311 2000 001	1	
44	411 823 563	Clamp - Conduit tube to Ch. No. 319 500 000	1	
45	N 13 957 3	Tapping screw, fillister hd. BZ 3.5 x 9.5	1	
46	N 16 195 1	Rivet 4 x 8.5 from Ch. No. 310 2000 001	1	
47	311 823 567	Clip - Guide tube from Ch. No. 319 000 001	1	
48	N 13 968 1	Tapping screw, fillister hd. B 4.8 x 13	1	
49	N 11 692 2	Washer 5.1	1	
50	411 823 651 A	Hood release mechanism in glove compartment from Ch. No. 319 000 001	1	311,313,315,317, 361,363,365,367
-	412 823 651 A	Hood release mechanism in glove compartment from Ch. No. 319 000 001 to 310 2500 000	1	312,314,316,318, 362,364,366,368
-	312 823 651	Hood release mechanism in glove compartment from Ch. No. 311 2000 001	1	312, 314, 316, 318, 362,364,366,368
51	N 13 506 3	Rivet body AN 4 x 8 x 6	3	
52	N 13 530 2	Rivet head K 4 x 11	3	
53	411 823 665	Knob for hood release mechanism from Ch. No. 319 000 001	1	

54	311 857 495	Escutcheon for hood release mechanism from Ch. No. 319 000 001	1
55	N 13 968 1	Tapping screw, fillister hd. B 4.8 x 13	1
56	N 12 225 1	Spring washer B 5	1
57	N 15 421 1	Speed nut	1
58	311 823 703 A	Weatherstrip - Front hood	1



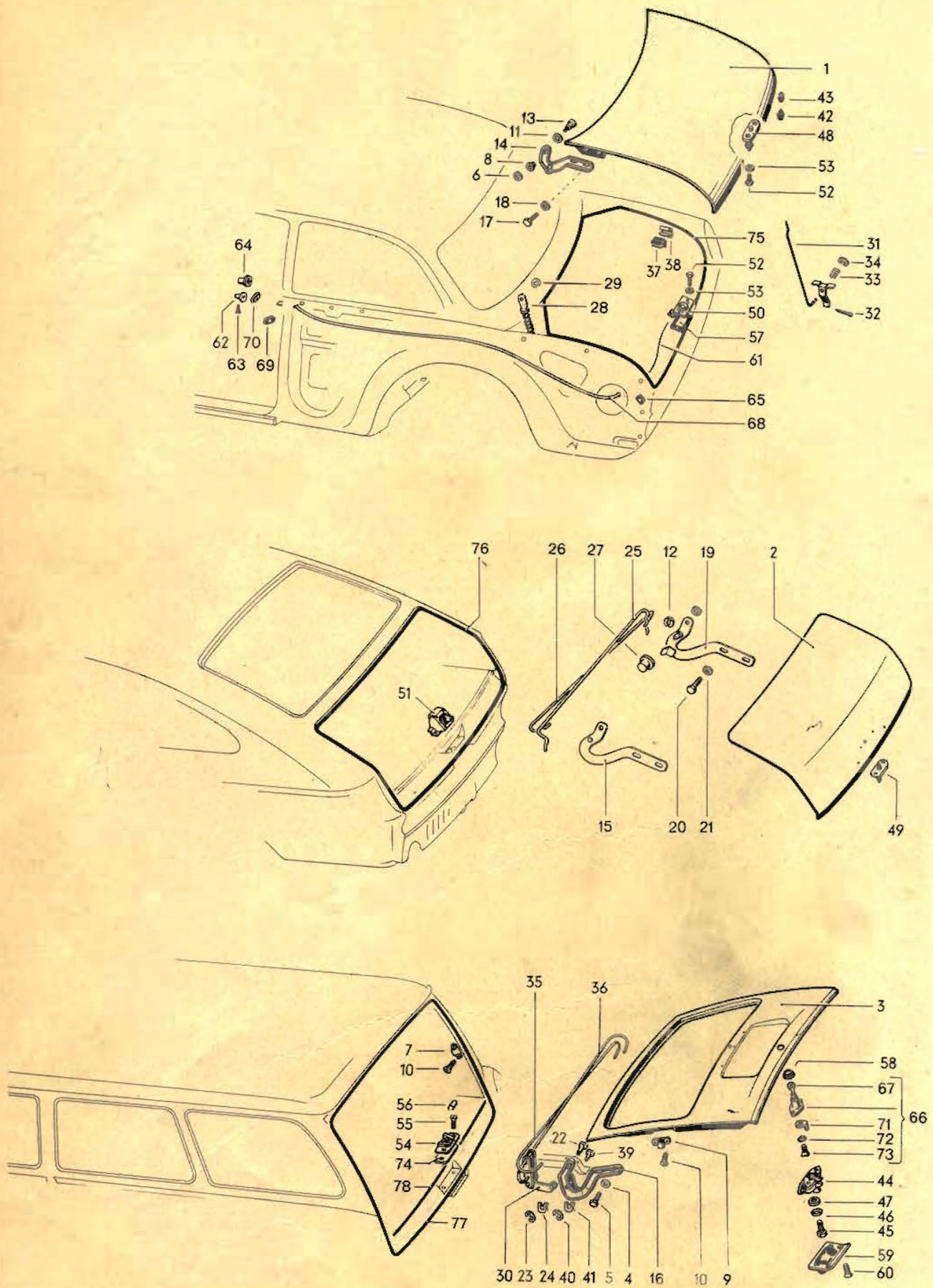

**MAIN GROUP 8**

**BODY**

Key	Part No.	Description	Qty.	Type and model
<b>REAR HOOD AND REAR DOOR</b>				
1	311 827 025 C	Hood, rear to Ch. No. 315 220 883 from Ch. No. 316 000 001	1 1	311-318 315-318
2	311 827 025 E	Hood, rear from Ch. No. 316 000 001 use: from Ch. No. 316 000 001 to 319 500 000 311 943 111 C	1	311-314
3	361 827 025 J	Rear door use 361 943 111 A/117 B/169 A/191 A to Ch. No. 367 500 000	1	361-368
-	N 20 025 1	Plug for hole in rear door for heatable rear window	2	
4	131 821 150	Spring washer	4	361-368
5	N 10 238 7	Bolt, hex. hd. M 8 x 15	4	361-368
6	311 827 181	Washer 8.3 - Rear hood hinge to Ch. No. 315 220 883 from Ch. No. 316 000 001	2 2	311-318 315-318
7	361 827 185 A	Adjustment plate - Guide piece	2	361-368
8	311 827 193	Bush - Rear hood hinge to Ch. No. 315 220 883 from Ch. No. 316 000 001	2 2	311-318 315-318
9	361 827 195	Guide piece for rear door	2	361-368
10	N 14 216 1	Screw, csk. hd. AM 5 x 10	8	361-368
11	311 827 197	Washer 10.1 x 18 for rear hood hinge	2	311-318
12	N 12 327 1	Lock washer	2	311-314
13	311 827 199	Screw - Rear hood hinge to Ch. No. 315 220 883 from Ch. No. 316 000 001	2 2	311-318 315-318
14	311 827 301 C	Hood hinge, rear left to Ch. No. 315 220 883 from Ch. No. 316 000 001	1 1	311-318 315-318
15	311 827 301 D	Hood hinge, rear left from Ch. No. 316 000 001	1	311-314

16	361 827 301	Hinge, left for rear door to Ch. No. 311 2500 000	1	361-368
-	361 827 301 B	Hinge, left for rear door from Ch. No. 312 2000 001	1	361-368
-	311 827 302 C	Hood hinge, rear right to Ch. No. 315 220 883 from Ch. No. 316 000 001	1 1	311-318 315-318
17	N 10 238 7	Bolt, hex. hd. M 8 x 15	4	315-318
18	131 821 150	Spring washer	4	315-318
19	311 827 302 D	Hood hinge, rear right from Ch. No. 316 000 001	1	311-314
-	361 827 302	Hinge, right for rear door	1	361-368
20	N 10 215 4	Bolt, hex. hd. M 6 x 15	4	311-314
21	211 805 243	Spring washer 6.5 x 17	4	311-314
22	361 827 325	Bolt - Hinge	2	361-368
23	N 12 436 2	Lock washer 6 to Ch. No. 369 076 517	2	361-368
24	N 12 646 1	Lock washer 6 from Ch. No. 369 076 518	2	361-368
25	311 827 349	Torsion bar, left for hood, rear from Ch. No. 316 000 001	1	311-314
26	311 827 350	Torsion bar, right - Hood, rear from Ch. No. 316 000 001	1	311-314
27	131 823 357	Guide roller - Torsion bar from Ch. No. 316 000 001	2	311-314
28	311 827 413 A	Hinge stay - Rear hood to Ch. No. 315 220 883 from Ch. No. 316 000 001	2 2	311-318 315-318
29	N 12 437 1	Lock washer 7	2	311-318
30	361 827 361	Hinge stay	2	361-368
31	315 827 363	Hinge stay - Rear hood from Ch. No. 221 975 to 483 592	1	315-318
32	N 12 522 1	Cotter pin 2 x 22	1	315-318
33	315 823 367	Spring - Hood support from Ch. No. 221 975 to 483 592	1	315-318
34	N 12 435 1	Lock washer 5	1	315-318
-	361 827 375	Torsion bar, left for rear door to Ch. No. 366 500 000	1	361-368
35	361 827 375 A	Torsion bar, left for rear door from Ch. No. 367 000 001	1	361-368
-	361 827 376	Torsion bar, right for rear door to Ch. No. 366 500 000	1	361-368



36	361 827 376 A	Torsion bar, right for rear door from Ch. No. 367 000 001	1	361-368
37	315 823 395	Rubber retainer for hood support from Ch. No. 221 975 to 483 592	1	315-318
38		Channel – Rubber retainer make from 111 813 169	1	315-318
39	361 827 399	Bolt – Hinge stay	2	361-368
40	N 12 436 2	Lock washer 6 to Ch. No. 369 076 517	2	361-368
41	N 12 646 1	Lock washer 6 from Ch. No. 369 076 518	2	361-368
42	311 827 499	Rubber stop – Rear hood to Ch. No. 221 974	2	311-314
43	311 823 499 A	Rubber stop – Rear hood from Ch. No. 221 975	2	311-318
44	361 827 505	Lock – Rear door to Ch. No. 311 2500 000	1	361-368
-	361 827 505 A	Lock – Rear door from Ch. No. 312 2000 001	1	361-368
45	N 10 215 4	Bolt, hex. hd. M 6 x 15	4	361-368
46	*111 837 941	Concave washer 6.4 x 12.5	4	361-368
47	N 11 695 2	Washer 6.1	4	361-368
48	311 827 507	Lock pin carrier for rear hood lock to Ch. No. 315 220 883 from Ch. No. 316 000 001	1 1	311-318 315-318
49	311 827 507 A	Lock pin carrier for rear hood lock from Ch. No. 316 000 001	1	311-314
50	311 827 509	Lock for rear hood to Ch. No. 315 220 883 from Ch. No. 316 000 001	1 1	311-318 315-318
51	311 827 509 B	Lock for rear hood from Ch. No. 316 000 001	1	311-314
52	N 10 210 7	Bolt, hex. hd. M 6 x 10 K	4	311-318
53	211 805 243	Spring washer 6.5 x 17	4	311-318
54	361 827 511 A	Striker plate to Ch. No. 311 2500 000	1	361-368
-	361 827 511 B	Striker plate from Ch. No. 312 2000 001	1	361-368
55	N 14 276 1	Screw, csk. raised hd. AM 8 x 12	2	361-368
56	361 827 513	Catch reinforcement for striker plate to Ch. No. 367 005 266	1	361-368

-	311 827 521	Seal for pin for lock pin carrier 311 827 507	1	315-318
57	311 827 523 A	Weatherstrip for rear hood lock to Ch. No. 315 220 883 from Ch. No. 316 000 001	1	311-318
-	311 827 531	Cable - Rear hood (length 2150 mm) to Ch. No. 188 309	1	311-314
58	361 827 527	Seal - Press button	1	361-368
59	361 827 529 A	Cover plate - Lock to Ch. No. 361 2500 000	1	361-368
60	N 14 276 1	Screw, csk. raised hd. AM 6 x 12	4	361-368
61	412 823 531	Cable - Rear hood (shorten to 2300 mm) from Ch. No. 188 310	1	311-318
62	311 827 535	Lever (lock pillar) for rear hood lock to Ch. No. 392 285	1	311-318
63	N 10 903 1	Screw, csk. hd. AM 3.5 x 8	1	311-318
64	311 827 535 A	Lever (lock pillar) for rear hood lock from Ch. No. 392 286	1	311-318
65	311 827 537 A	Grommet, rear for hood lock cable to Ch. No. 188 309	1	311-314
66	361 827 539 A	Press button with keys for rear door (key profile M) to Ch. No. 361 2500 000	1	361-368
-	361 827 539 B	Press button with keys for rear door (key profile M) from Ch. No. 362 2000 001	1	361-368
67	111 837 219 A	Key blank (for finished keys specify key number)	1	361-368
	4/61 - 7/66	S80 Profile A		
	8/66 - 7/70	S66 Profile K		
	8/70 -	S92 Profile M		
68	311 827 545 A	Conduit tube for lock cable, rear from Ch. No. 188 310	1	311-318
69	311 827 547	Grommet, front for hood lock cable to Ch. No. 188 309	1	311-314
70	311 827 549	Seal (lock pillar) for lever	1	311-318
71	361 827 553	Eccentric - Press button to Ch. No. 269 422	1	361-368
72	N 12 116 1	Spring washer V 4.3	1	361-368

73	N 11 734 1	Screw, csk. hd. AM 4 x 8	1	361-368
74	361 827 599 A	Spacer plate 1.5 mm for striker plate	X	361-368
75	311 827 705	Weatherstrip - Hood, rear		
		to Ch. No. 315 220 883	1	311-318
		from Ch. No. 316 000 001	1	315-318
76	311 827 705 A	Weatherstrip - Hood, rear	1	311-314
		from Ch. No. 316 000 001		
77	361 827 705	Weatherstrip - Rear door	1	361-368
78	461 827 715	Weatherstrip, inner, lower	1	361-368
		for rear door		

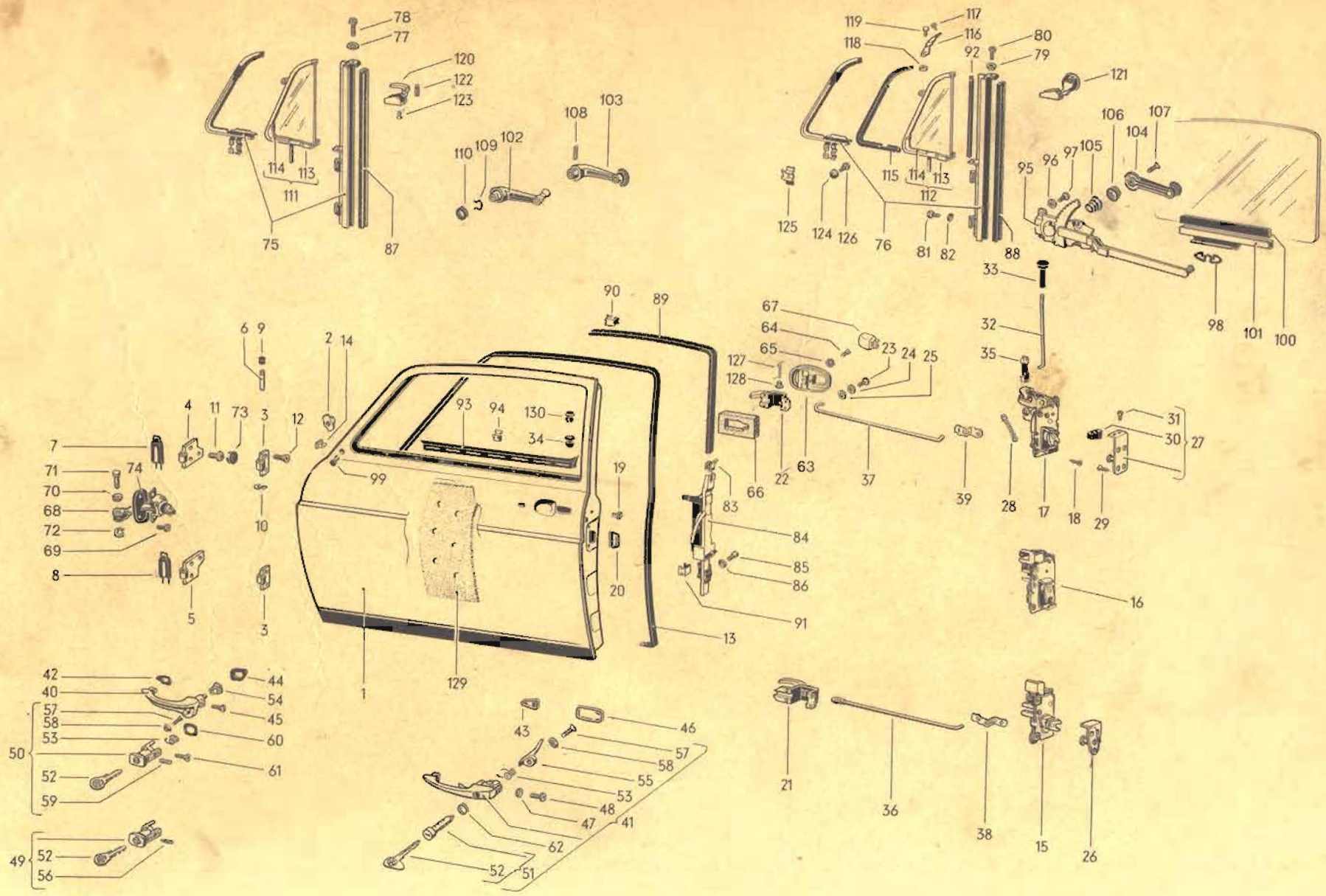

Illustration 45

Supplement 8

Type 3

**MAIN GROUP 8**

**BODY**

Key Part No. Description Qty. Type and model

**DOORS**

(see VW Parts Service Bulletin 8/2)

-	315 831 051 G	Door, bare, left to Ch. No. 221 974 from Ch. No. 221 975 to 317 500 000	1 1	311-314, 361-364 311-314, 315, 317, 361-368
1	315 831 051 K	Door, bare, left from Ch. No. 318 000 001	1	
-	316 831 051 L	Door, bare, left from Ch. No. 221 975 to 317 500 000	1	316, 318
-	316 831 052 K	Door, bare, right from Ch. No. 318 000 001	1	
-	316 831 052 F	Door, bare, right to Ch. No. 317 500 000	1	
-	315 831 111 J	Door outer panel, left	1	
-	316 831 112 J	Door outer panel, right	1	
2	311 831 155 A	Threaded plate for rear view mirror	1	
3	*311 831 405 C	Hinge half from Ch. No. 316 218 360	4	311-314, 361-368
4	*311 831 405 D	Hinge half, upper left to Ch. No. 315 220 883 to Ch. No. 316 218 359 from Ch. No. 316 218 360	1 1 1	311-314 315-318, 361-368 315-318
-	*311 831 406 B	Hinge half, upper right to Ch. No. 315 220 883 to Ch. No. 316 218 359 from Ch. No. 316 218 360	1 1 1	311-314 315-318, 361-368 315-318
5	*311 831 415 B	Hinge half, lower left to Ch. No. 315 220 883 to Ch. No. 316 218 359 from Ch. No. 316 218 360	1 1 1	311-314 315-318, 361-368 315-318
-	*311 831 416 B	Hinge half, lower right to Ch. No. 315 220 883 to Ch. No. 316 218 359 from Ch. No. 316 218 360	1 1 1	311-314 315-318, 361-368 315-318
6	*311 831 421 D	Pin - Hinge	4	
-	311 831 421 E	Pin - Hinge (oversize) to Ch. No. 310 2500 000	X	
-	311 831 421 F	Pin - Hinge (2nd oversize) to Ch. No. 310 2500 000	X	
7	311 831 425 A	Sealing rubber for door hinge, upper left to Ch. No. 315 220 883 from Ch. No. 316 000 001	1 1	315-318, 361-368

-	311 831 426	Sealing rubber for door hinge, upper right to Ch. No. 315 220 883 from Ch. No. 316 000 001	1 1	315-318, 361-368
8	311 831 429 A	Sealing rubber for door hinge, lower left to Ch. No. 315 220 883 from Ch. No. 316 000 001	1 1	315-318, 361-368
-	311 831 430	Sealing rubber for door hinge, lower right to Ch. No. 315 220 883 from Ch. No. 316 000 001	1 1	315-318, 365-368
9	*311 831 439 A	Plug - Door hinge 908 transparent	4	
10	*311 831 443	Spring washer - Hinge from Ch. No. 315 156 150	4	
11	*311 831 455	Screw - Door hinge to Ch. No. 315 220 883 from Ch. No. 316 000 001	12 12	315-318, 361-368
12	N 21 401 1	Screw, csk. raised hd. M 8x18 for hinge	8	311-314
13	311 831 711 F	Weatherstrip - Door, left	1	
-	311 831 712 F	Weatherstrip - Door, right	1	
14	311 831 719	Clip for door weatherstrip 311 831 711 F/712 F	4 4	

**DOOR COMPONENTS**

15	311 837 015	Door lock, left to Ch. No. 316 500 000	1	
16	111 837 015 D	Door lock, left from Ch. No. 317 000 001 to 317 500 000	1	
17	111 837 015 F	Door lock, left from Ch. No. 318 000 001 to 311 2500 000	1	
-	111 837 015 G	Door lock, left from Ch. No. 312 2000 001	1	
-	311 837 016	Door lock, right to Ch. No. 316 500 000	1	
-	111 837 016 D	Door lock, right from Ch. No. 317 000 001 to 317 500 000	1	
-	111 837 016 F	Door lock, right from Ch. No. 318 000 001 to 311 2500 000	1	
-	111 837 016 G	Door lock, right from Ch. No. 312 2000 001	1	
18	N 14 276 1	Screw, csk. raised hd. AM 6x12	6	
19	111 837 111 C	*Plug for door lock oil hole from Ch. No. 317 000 001	2	

20	111 837 143	*Gasket - Door lock from Ch. No. 317 000 001	2
21	311 837 019	Operating lever for door lock, left to Ch. No. 316 500 000	1
-	113 837 019	Operating lever for door lock, left from Ch. No. 317 000 001 to 317 500 000	1
22	113 837 019 B	Operating lever for door lock, left from Ch. No. 318 000 001 to 311 2500 000	1
-	111 837 019 H	Operating lever for door lock, left from Ch. No. 312 2000 001	1
-	311 837 020	Operating lever for door lock, right to Ch. No. 316 500 000	1
-	113 837 020 B	Operating lever for door lock, right from Ch. No. 317 000 001 to 311 2500 000	1
-	111 837 020 H	Operating lever for door lock, right from Ch. No. 312 2000 001	1
23	N 10 210 7	Bolt, hex. hd. M 6x10 K	4
24	111 837 941	Concave washer	4
25	N 11 524 4	Washer A 6.4	4
26	311 837 035	Striker plate - Door lock, left to Ch. No. 316 500 000	1
27	111 837 035 D	Striker plate - Door lock, left from Ch. No. 317 000 001 to 311 2500 000	1
-	111 837 035 E	Striker plate - Door lock, left from Ch. No. 312 2000 001	1
-	311 837 036	Striker plate - Door lock, right to Ch. No. 316 500 000	1
-	111 837 036 D	Striker plate - Door lock, right from Ch. No. 317 000 001 to 311 2500 000	1
-	111 837 036 E	Striker plate - Door lock, right from Ch. No. 312 2000 001	1
28	111 837 061 A	Spring - Door lock 111 837 015 D/F/016 D/F to Ch. No. 311 2500 000	1
-	111 837 061 C	Spring - Door lock 111 837 015 G/016 G from Ch. No. 312 2000 001	1
29	N 14 276 1	Screw, csk. raised hd. AM 6x12	8
30	311 837 177	Rubber wedge - Striker plate to Ch. No. 311 2500 000	2
-	311 837 177 A	Rubber wedge - Striker plate from Ch. No. 312 2000 001	2

31	N 11 734 1	Screw, csk. hd. AM 4x8	4
32	311 837 183	Locking rod from Ch. No. 317 000 001	2
33	111 837 187 B	Knob - Locking rod from Ch. No. 317 000 001	2
34	111 837 355	*Guide - Knob from Ch. No. 317 000 001	2
35	111 837 319	*Spring, left for locking rod from Ch. No. 317 000 001	1
-	111 837 320	*Spring, right for locking rod from Ch. No. 317 000 001	1
36	311 837 193	Pull rod for operating lever, left to Ch. No. 316 500 000	1
37	311 837 193 A	Pull rod - Operating lever from Ch. No. 317 000 001	2
-	311 837 194	Pull rod for operating lever, right to Ch. No. 316 500 000	1
38	311 837 199	Spring - Pull rod 40 mm - 1 9/16 in. to Ch. No. 316 500 000	2
39	113 837 199	Spring - Pull rod 37.5 mm - 1 15/32 in. from Ch. No. 317 000 001	2
40	311 837 205	Door handle, outer left (operating pin protrudes 18 mm - 23/32 in.) see workshop bulletin A 66 to Ch. No. 316 500 000	1
-	311 837 205 A	Door handle, outer left (operating pin protrudes 13 mm - 1/2 in.) from Ch. No. 317 000 001 to 317 500 000	1
41	311 837 205 E	Door handle, outer left (with lock cylinder) from Ch. No. 318 000 001 to 311 2500 000	1
-	311 837 205 F	Door handle, outer left (with lock cylinder) from Ch. No. 312 2000 001	1
-	311 837 206	Door handle, outer right (operating pin protrudes 18 mm - 23/32 in.) see workshop bulletin A 66 to Ch. No. 317 500 000	1
-	311 837 206 B	Door handle, outer right (with lock cylinder) from Ch. No. 318 000 001 to 319 500 000	1



-	311 837 206 E	Door handle, outer right (with lock cylinder) from Ch. No. 310 2000 001 to 311 2500 000	1
-	311 837 206 F	Door handle, outer right (with lock cylinder) from Ch. No. 312 2000 001	1
42	311 837 209	Packing, front for door handle, outer to Ch. No. 317 500 000	2
43	111 837 209 B	Packing, front for door handle, outer from Ch. No. 318 000 001	2
44	311 837 211	Packing, rear for door handle, outer to Ch. No. 317 500 000	2
45	N 14 275 1	Screw, csk. raised hd. AM 6x10	2
46	111 837 211 C	Packing, rear for door handle, outer from Ch. No. 318 000 001	2
47	111 837 941	Concave washer	2
48	N 14 138 9	Screw, fillister hd. AM 6x10	2
49	*311 837 217	Lock cylinder with keys Profile A to Ch. No. 316 500 000	2
50	*311 837 217 A	Lock cylinder with keys Profile K from Ch. No. 317 000 001 to 317 500 000	2
51	111 837 217 D	Lock cylinder with keys Profile K Door handle 311 837 205 B/206 B from Ch. No. 318 000 001 to 310 2500 000	2
-	111 837 217 E	Lock cylinder with keys Profile M from Ch. No. 311 2000 001	2
52	*111 837 219 A	Key (for finished keys give specify key number)	2
	4 61 - 7/66	S80 Profile A	
	8 66 - 7 70	S66 Profile K	
	8 70 -	S92 Profile M	
53	311 837 221	Return spring - Lock cylinder	2
54	311 837 223	Thrust piece for door handle see workshop bulletin A 66 (only for 312 831 051 J/315 831 051 G/ 316 831 051 L/311 831 052 J/315 831 052 L/ 316 831 052 F)	X
55	311 837 223 A	Eccentric, left for door handle 311 837 205 B/E/F	1
-	311 837 224	Eccentric, right for door handle 311 837 206 B /E/F	1
56	N 13 044 1	Set screw M 2.6x8	2
57	N 11 734 1	Screw, csk. hd. AM 4x8	2

58	N 12 116 1	Lock washer V 4,3	2	
59	N 13 331 1	Slotted pin 2x12	2	
60	311 837 227	Packing - Lock cylinder to Ch. No. 317 500 000	2	
61	N 14 276 1	Screw, csk. raised hd. AM 6x12	2	
62	111 837 227 B	Seal - Lock cylinder from Ch. No. 318 000 001	2	
-	111 837 230	Rubber cap - Key blank from Ch. No. 311 2000 001	X	
63	113 837 239 B	Escutcheon - Operating lever to Ch. No. August 1971	2	
-	111 837 239 B	Escutcheon - Operating lever from Ch. No. September 1971	2	
64	N 14 216 1	Screw, csk. hd. AM 5x10	4	
65	N 12 113 1	Lock washer V 5.3 from Ch. No. 310 2124 862	4	
-	111 837 291	*Cone washer 11.5 from Ch. No. 310 2124 863	2	
66	111 837 341	*Seal - Operating lever	2	
67	311 837 247	Trim plate - Operating lever	2	
	4 61 - 7/66	466 silver beige		
	8 66 -	043 grey-black		
68	311 837 249 A	Check rod - Door	2	
69	N 14 140 5	Screw, fillister hd. AM 6x15	4	
70	311 837 943	Concave washer 6.4 x 18	4	
71	311 837 257 A	Pin - Door check rod	2	
72	N 12 435 1	Lock washer 5	2	
73	311 837 347	Rubber cap for door hinge screws to Ch. No. 315 220 883	12	
		from Ch. No. 316 000 001 to 316 113 513	12	315-318, 361-368
		from Ch. No. 316 113 514	12	315-318
74	311 837 349	Cover for check rod, left to Ch. No. 315 220 883	1	
		from Ch. No. 316 000 001 to 316 113 513	1	315-318, 365-368
-	311 837 350	Cover for check rod, right to Ch. No. 315 220 883	1	
		from Ch. No. 316 000 001 to 316 113 513	1	315-318, 365-368
75	311 837 405 B	Window channel with vent wing frame, left to Ch. No. 317 500 000	1	311-314, 361-364
76	311 837 405 C	Window channel with vent wing frame, left from Ch. No. 318 000 001	1	311-314, 361-364
-	315 837 405 A	Window channel with vent wing frame, left from Ch. No. 221 975 to 317 500 000	1	315-318, 365-368

-	315 837 405 B	Window channel with vent wing frame, left from Ch. No. 318 000 001	1	315-318, 365-368
-	311 837 406 B	Window channel with vent wing frame, right to Ch. No. 317 500 000	1	311-314, 361-364
-	311 837 406 C	Window channel with vent wing frame, right from Ch. No. 318 000 001	1	311-314, 361-364
-	315 837 406 A	Window channel with vent wing frame, right from Ch. No. 221 975 to 317 500 000	1	315-318, 365-368
-	315 837 406 B	Window channel with vent wing frame, right from Ch. No. 318 000 001	1	315-318, 365-368
77	N 12 224 3	Spring washer B 4 to Ch. No. 316 181 754	4	
78	N 14 123 3	Screw, fillister hd. AM 4x10 to Ch. No. 316 181 754	4	
79	111 837 939	Concave washer 5.3 x 12.5 from Ch. No. 316 181 755	2	
80	N 10 704 2	Screw, cheese hd. AM 5x10 from Ch. No. 316 181 755	2	
81	N 10 210 7	Bolt, hex. hd. M 6x10 K	4	
82	311 837 943	Concave washer 6.4 x 18	4	
83	111 837 421	Clip, upper for channel, rear	2	
84	311 837 429 B	Channel, rear, left	1	
-	311 837 430 B	Channel, rear, right	1	
85	N 10 210 7	Bolt, hex. hd. M 6x10 K	2	
86	111 837 941	Concave washer	2	
87	311 837 433	Channel, front - Door window to Ch. No. 315 220 883	2	
88	311 837 433 A	Channel, front - Door window from Ch. No. 316 000 001	2	
89	111 837 439 D	Channel, rear - Door window	2	
90	111 837 361	Clip, upper for channel, rear	12	
91	311 837 443 A	Clip, lower for channel, rear to Ch. No. 316 181 754	2	
-	311 837 465	Weatherstrip rear for vent wing to Ch. No. 315 220 883	2	
92	241 837 465	Weatherstrip rear for vent wing from Ch. No. 316 000 001	2	

93	311 837 475 B	Weatherstrip for door window slot, left	1	
-	311 837 476 B	Weatherstrip for door window slot, right	1	
94	311 837 485	Clip for channel on window slot	2	
-	311 837 501	Winder - Door window, left to Ch. No. 317 500 000	1	
95	311 837 501 A	Winder - Door window, left from Ch. No. 318 000 001	1	
-	311 837 502	Winder - Door window, right to Ch. No. 317 500 000	1	
-	311 837 502 A	Winder - Door window, right from Ch. No. 318 000 001	1	
96	111 837 941	Concave washer	8	
97	N 10 210 7	Bolt, hex. hd. M 6x10 K	8	
98	111 837 507	Spring for window winder	2	
99	311 837 521 A	Cap for mirror opening	X	
100	111 837 565 C	Weatherstrip - Lift channel	2	
101	111 837 571 B	Lift channel - Door window	2	
102	311 837 581 C	Handle - Door window winder to Ch. No. 316 500 000	2	
103	311 837 581 E	Handle - Door window winder from Ch. No. 317 000 001 to 317 500 000 043 grey-black	2	
	8/66 - 7/67			
104	113 837 581 D	Handle - Door window winder from Ch. No. 318 000 001 to August 1971	2	
-	111 837 581 H	Handle - Door window winder from Ch. No. September 1971	2	
105	111 837 229 C	*Spring - Door window winder handle	2	
106	311 837 595	Escutcheon - Window winder handle from Ch. No. 318 000 001 to August 1971	2	
-	111 837 595 A	Escutcheon - Window winder handle from Ch. No. September 1971	2	
107	N 14 216 5	Screw, csk. hd. AM 5 x 10	2	
108	N 12 810 1	Dowel pin 3x10	2	
109	311 837 593	Spring - Window winder handle to Ch. No. 317 500 000	2	
110	311 837 597	Escutcheon - Window winder handle to Ch. No. 317 500 000	2	
111	311 837 605	Vent wing, left to Ch. No. 317 500 000	1	311-314, 361-364
112	311 837 605 A	Vent wing, left from Ch. No. 318 000 001	1	311-314, 361-364
-	315 837 605	Vent wing, left from Ch. No. 221 975 to 317 500 000	1	315-318, 365-368

-	315 837 605 A	Vent wing, left from Ch. No. 318 000 001	1	315-318, 365-368
-	311 837 606	Vent wing, right to Ch. No. 317 500 000	1	311-314, 361-364
-	311 837 606 A	Vent wing, right from Ch. No. 318 000 001	1	311-314, 361-364
-	315 837 606	Vent wing, right from Ch. No. 221 975 to 317 500 000	1	315-318, 365-368
-	315 837 606 A	Vent wing, right from Ch. No. 318 000 001	1	315-318, 365-368
113	311 837 609	Frame - Vent wing, left	1	311-314, 361-364
-	315 837 609	Frame - Vent wing, left from Ch. No. 221 975	1	315-318, 365-368
-	311 837 610	Frame - Vent wing, right	1	311-314, 361-364
-	315 837 610	Frame - Vent wing, right from Ch. No. 221 975	1	315-318, 365-368
114	311 837 621	Gutter, left	1	311-314, 361-364
-	315 837 621	Gutter, left from Ch. No. 221 975	1	315-318, 365-368
-	311 837 622	Gutter, right	1	311-314, 361-364
-	315 837 622	Gutter, right from Ch. No. 221 975	1	315-318, 365-368
115	311 837 625 A	Weatherstrip - Vent wing, left use 241 837 465	1	
-	311 837 626 A	Weatherstrip - Vent wing, right use 241 837 465	1	
116	311 837 631	Mounting bracket, upper - Vent wing, left	1	
-	311 837 632	Mounting bracket, upper - Vent wing, right	1	
117	N 13 657 1	Rivet A 3x6.5	4	
118	111 837 637	Washer - Mounting bracket	2	
119	N 13 661 2	Rivet B 4x8	2	
120	311 837 639	Fastener - Vent wing, left to Ch. No. 317 500 000	1	
121	311 837 657	Fastener - Vent wing, left from Ch. No. 318 000 001 to 311 2500 000	1	
-	311 837 657 A	Fastener - Vent wing, left from Ch. No. 312 2000 001	1	
-	311 837 640	Fastener - Vent wing, right to Ch. No. 317 500 000	1	
-	311 837 658 A	Fastener - Vent wing, right from Ch. No. 318 000 001	1	
122	N 13 331 1	Pin 2x12	2	
123	N 13 736 3	Rivet 3x6	4	
124	311 837 943	Concave washer 6.4 x 18	6	
125	311 837 683	Clamp, top - Vent wing	2	
126	N 14 138 9	Screw, fillister hd. AM 6 x 10	2	
127	311 837 723	Spring - Operating lever	2	
128	N 13 666 1	Rivet B 4x32	2	

129	111 837 807 A	Sound absorber – Door panel (self adhesive)	X
130	311 837 955	Plug for locking rod hole to Ch. No. 316 500 000	2



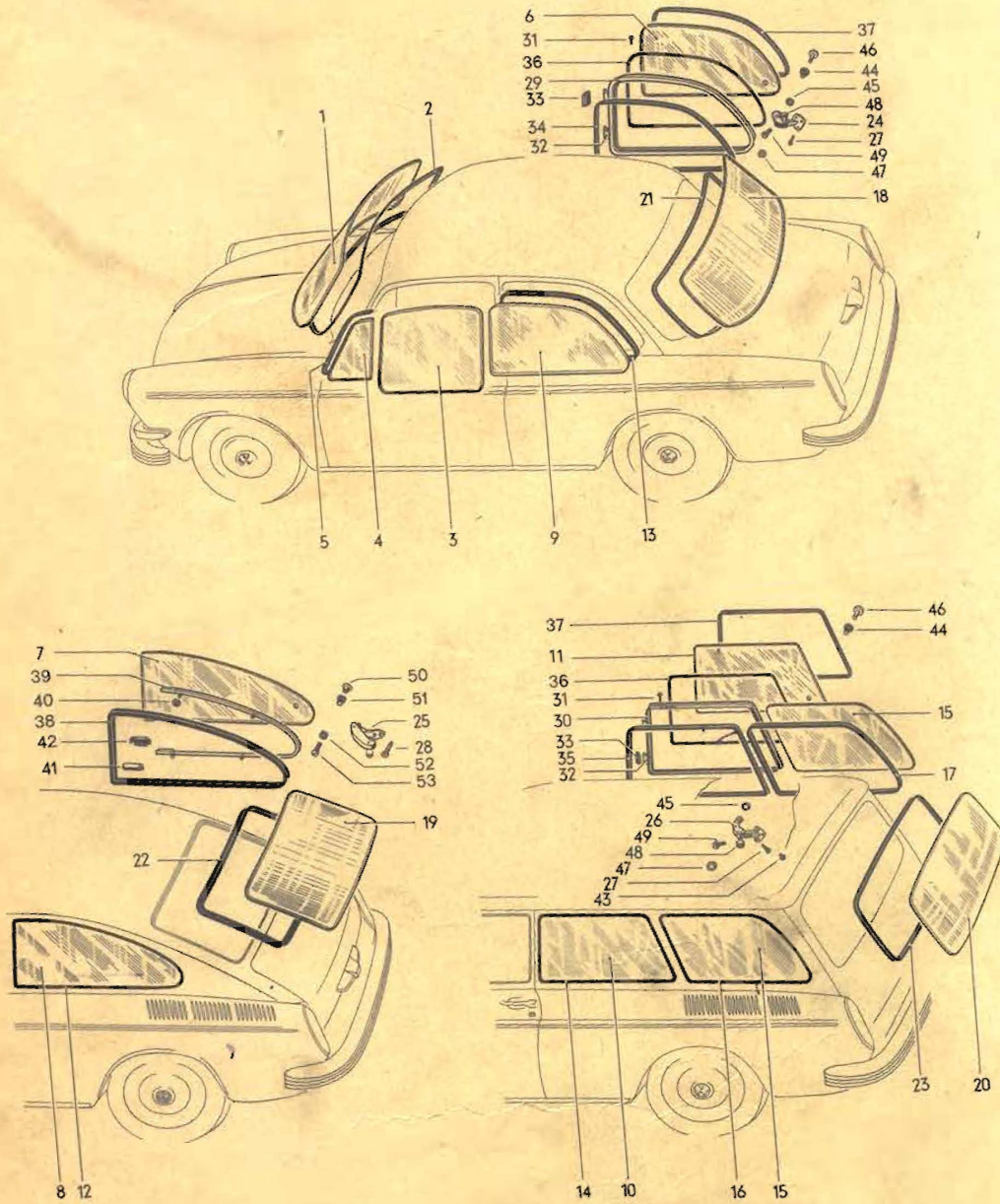



**MAIN GROUP 8**

**BODY**

Key	Part No.	Description	Qty.	Type and model
<b>WINDOW GLASS AND WEATHERSTRIPS</b>				
1	311 845 101	Glass - Windshield to Ch. No. 310 2163 308	1	
-	311 845 101 D	Glass - Windshield (laminated) use: to Ch. No. 310 2074 068 311 845 141/143 (see VW Parts Service Bulletin 8/35)	1	M 89
-	311 845 101 E	Glass - Windshield from Ch. No. 310 2163 309 (see VW Parts Service Bulletin 8/35)	1	
2	311 845 121 B	Weatherstrip - Windshield glass to Ch. No. 310 2163 308	1	
-	311 845 121 D	Weatherstrip - Windshield glass to Ch. No. 310 2074 069 (see VW Parts Service Bulletin 8/35)	1	M 89
-	312 845 121 F	Weatherstrip - Windshield glass from Ch. No. 310 2163 309 (see VW Parts Service Bulletin 8/35)	1	
3	311 845 201	Glass - Door	2	
-	311 845 141	Clamping strip 996 mm - Windshield glass weatherstrip to Ch. No. 310 2074 069 (see VW Parts Service Bulletin 8/35)	X	M 89
-	311 845 143	Clamping strip 1236 mm - Windshield glass weatherstrip to Ch. No. 310 2074 069 (see VW Parts Service Bulletin 8/35)	X	M 89
4	311 845 251	Glass - Vent wing	2	
5	221 845 295	Weatherstrip for vent wing glass	2	
6	311 845 301	Glass - Hinged quarter window to Ch. No. 315 220 883 from Ch. No. 317 000 001 to 310 2500 000 from Ch. No. 221 975	2 2 2	311-314 M 234 M 93: 315-318
7	311 845 301 A	Glas - Hinged quarter window from Ch. No. 316 000 001 to 310 2500 000 from Ch. No. 311 2000 001	2 2	311-314 M 93: 311-314
8	311 845 301 B	Glass - Hinged quarter window, left from Ch. No. 310 000 001 to 310 2500 000 from Ch. No. 311 2000 001	1 1	M 233 311-314
9	315 845 301	Glass - Quarter window from Ch. No. 221 975	2	315-318

10	361 845 301 A	Glass - Quarter window, front to Ch. No. 221 974	2	361-364
		from Ch. No. 221 975 to 310 2500 000	2	365-368
		from Ch. No. 311 2000 001	2	361-364
11	361 845 301 B	Glass - Hinged quarter window from Ch. No. 112 203 to 221 974	2	M 93: 361-364
		from Ch. No. 221 975 to 310 2500 000	2	361-364; M 93: 365-368
-	361 845 301 C	Glass - Hinged quarter window from Ch. No. 311 2000 001	2	M 93: 361-368
-	311 845 302 A	Glass - Quarter window, right from Ch. No. 319 000 001 to 310 2500 000	1	M 233
		from Ch. No. 311 2000 001	1	311-314
12	311 845 321	Weatherstrip for quarter window glass, left from Ch. No. 319 000 001 to 310 2500 000	1	M 233
		from Ch. No. 311 2000 001	1	311-314
13	315 845 321	Weatherstrip for quarter window glass, left from Ch. No. 221 975	1	315-318
-	361 845 321	Weatherstrip for quarter window glass, front, left to Ch. No. 221 974	1	361-364
14	361 845 321 A	Weatherstrip for quarter window glass, front, left from Ch. No. 221 975 to 310 2500 000	1	365-368
		from Ch. No. 311 2000 001	1	361-364
-	311 845 322	Weatherstrip for quarter window glass, right from Ch. No. 319 000 001 to 310 2500 000	1	M 233
		from Ch. No. 311 2000 001	1	311-314
-	315 845 322	Weatherstrip for quarter window glass, right from Ch. No. 221 975	1	315-318
-	361 845 322 A	Weatherstrip for quarter window glass, front, right to Ch. No. 221 974	1	361-364
		from Ch. No. 221 975 to 310 2500 000	1	365-368
		from Ch. No. 311 2000 001	1	361-364
15	361 845 331	Glass - Quarter window, rear	2	361-368
16	361 845 341 A	Weatherstrip for quarter window glass, rear, left	1	361-368
17	361 845 342 A	Weatherstrip for quarter window glass, rear, right	1	361-368
18	311 845 501	Glass - Rear window to Ch. No. 315 220 883	1	311-318
		from Ch. No. 316 000 001	1	315-318
19	311 845 501 A	Glass - Rear window from Ch. No. 316 000 001	1	311-314

-	311 845 501 B	Glass - Rear window (heat protection glass) from Ch. No. 316 000 001	1	M 244: 311-314
-	311 845 501 C	Glass (heatable 12 V) - Rear window from Ch. No. 317 000 001	1	M 102: 311-314
-	311 845 501 D	Glass (heatable 12 V) - Rear window (heat protection glass) from Ch. No. 317 000 001	1	M 102/M 244
-	311 845 501 E	Glass (heatable 6 V) - Rear window from Ch. No. 316 000 001 to 316 500 000	1	M 102: 311-314
-	315 845 501	Glass (heatable 12 V) - Rear window from Ch. No. 317 000 001	1	M 102: 315-318
-	315 845 501 A	Glass (heatable 6 V) - Rear window to Ch. No. 315 220 883 from Ch. No. 316 000 001 to 316 500 000	1 1	M 102: 311-318 M 102: 315-318
20	361 845 501	Glass - Rear window	1	361-368
-	361 845 501 A	Glass (heatable 12 V) - Rear window from Ch. No. 367 000 001	1	M 102: 361-368
-	111 998 131	1 set of installation parts for heatable rear window glass 6 V to Ch. No. 316 500 000	1	M 102: 311-318
-	111 998 133	1 set of installation parts for glass (heatable 12 V) - Rear window from Ch. No. 317 000 001	1	M 102
21	311 845 521 B	Weatherstrip for rear window glass to Ch. No. 315 220 883 from Ch. No. 316 000 001	1 1	311-318 315-318
22	311 845 521 C	Weatherstrip for rear window glass from Ch. No. 316 000 001	1	311-314
23	361 845 521 A	Weatherstrip for rear window glass	1	361-368
<b>PARTS FOR HINGED QUARTER WINDOWS</b>				
-	311 847 081	Fastener, left from Ch. No. 311 2000 001	1	M 93: 315-318
-	311 847 081 A	Fastener, left from Ch. No. 316 000 001 to 310 2500 000 from Ch. No. 311 2000 001	1 1	311-314 M 93: 311-314
-	361 847 081 A	Fastener, left from Ch. No. 112 203 to 221 974 from Ch. No. 221 975 to 310 2500 000	1 1	M 93: 361-364 361-364; M 93: 365-368
24	361 847 081 A	Fastener, right to Ch. No. 315 220 883 from Ch. No. 221 975 to 310 2500 000 from Ch. No. 317 000 001 to 310 2500 001	1 1 1	311-314 M 93: 315-318 M 234

-	461 847 081	Fastener from Ch. No. 311 2000 001	2	M 93: 361-368
-	311 847 082	Fastener, right from Ch. No. 311 2000 001	1	M 93: 315-318
25	311 847 082 A	Fastener, right from Ch. No. 316 000 001 to 2500 000	1	311-314
		from Ch. No. 311 2000 001	1	M 93: 311-314
26	361 847 082 A	Fastener, right from Ch. No. 112 203 to 221 974	1	M 93: 361-364
		from Ch. No. 221 975 to 310 2500 000	1	361-364; M 93: 365-368
-	361 847 082 A	Fastener, left to Ch. No. 315 220 883	1	311-314
		from Ch. No. 221 975 to 310 2500 000	1	M 93: 315-318
		from Ch. No. 317 000 001 to 310 2500 000	1	M 234
-	N 14 256 1	Screw, csk. raised hd. AM 4 x 18 to Ch. No. 112 202	6	311-314
		from Ch. No. 112 203 to 221 974	6	311-314; M 93: 361-364
		from Ch. No. 221 975 to 315 220 883	6	311-314, 361-364, M 93: 315-318, 365-368
		from Ch. No. 316 000 001 to 316 500 000	6	361-364; M 93: 315-318, 365-368
		from Ch. No. 317 000 001 to 317 154 757	6	361-364; M 93: 315-318, 365-368; M 234
-	N 14 279 2	Screw, csk. raised hd. AM 6 x 20 from Ch. No. 316 000 001 to 317 154 757	4	311-314
27	N 15 913 2	Tapping screw, csk. hd. A 4.3 x 22 from Ch. No. 317 154 758 to 310 2500 000	6	361-364; M 93: 315-318, 365-368, M 234
		from Ch. No. 311 2000 001	6	M 93: 315-318, 361-368
28	N 15 912 2	Tapping screw, csk. hd. A 6.5 x 25 from Ch. No. 317 154 758 to 310 2500 000	4	311-314
		from Ch. No. 311 2000 001	4	M 93: 311-314
-	311 847 101 A	Frame for hinged quarter window left to Ch. No. 315 220 883	1	311-314
		from Ch. No. 317 000 001 to 310 2500 000	1	M 234
		from Ch. No. 221 975	1	M 93: 315-318
-	361 847 101 A	Frame for hinged quarter window left from Ch. No. 112 203 to 221 974	1	M 93: 361-364
		from Ch. No. 221 975 to 310 2500 000	1	361-364; M 93: 365-368
		from Ch. No. 311 2000 001	1	M 93: 361-368
29	311 847 102 A	Frame for hinged quarter window right to Ch. No. 315 220 883	1	311-314
		from Ch. No. 317 000 001 to 310 2500 000	1	M 234
		from Ch. No. 221 975	1	M 93: 315-318

30	361 847 102 A	Frame		
		for hinged quarter window right		
		from Ch. No. 112 203 to 221 974	1	M 93: 361-364
		from Ch. No. 221 975 to 310 2500 000	1	361-364; M 93: 365-368
		from Ch. No. 311 2000 001	1	M 93: 361-368
31	N 10 905 1	Screw, csk. hd. AM 3.5 x 5		
		to Ch. No. 112 202	16	311-314
		from Ch. No. 112 203 to 221 974	16	311-314; M 93: 361-364
		from Ch. No. 221 975 to 315 220 883	16	311-314, 361-364; M 93: 315-318, 365-368
		from Ch. No. 316 000 001 to 316 500 000	16	361-364; M 93: 315-318, 365-368
		from Ch. No. 317 000 001 to 310 2500 000	16	361-364; M 93: 315-318, 365-368; M 234
		from Ch. No. 311 2000 001	16	M 93: 315-318, 361-368
32	311 847 125 A	Hinge hook		
		to Ch. No. 112 202	4	311-314
		from Ch. No. 112 203 to 221 974	4	311-314; M 93: 361-364
		from Ch. No. 221 975 to 315 220 883	4	311-314, 361-364; M 93: 315-318, 365-368
		from Ch. No. 316 000 001 to 316 500 000	4	361-364; M 93: 315-318, 365-368
		from Ch. No. 317 000 001 to 310 2500 000	4	361-364; M 93: 315-318, 365-368; M 234
		from Ch. No. 311 2000 001	4	M 93: 315-318, 361-368
33	311 847 129 B	Protective strip - Hinge		
		to Ch. No. 112 202	4	311-314
		from Ch. No. 112 203 to 221 974	4	311-314; M 93: 361-364
		from Ch. No. 221 975 to 315 220 883	4	311-314, 361-364; M 93: 315-318, 365-368
		from Ch. No. 316 000 001 to 316 500 000	4	361-364; M 93: 315-318, 365-368
		from Ch. No. 317 000 001 to 310 2500 000	4	361-364; M 93: 315-318, 365-368; M 234
		from Ch. No. 311 2000 001	4	M 93: 315-318, 361-368
34	*311 847 131 A	Beading - Hinged quarter window		
		from Ch. No. 28 883 to 315 220 883	2	311-314
		from Ch. No. 317 000 001 to 310 2500 000	2	M 234
		from Ch. No. 221 975	2	M 93: 315-318
	3/62 - 7/64	466 silver beige		
	8/64 - 7/57	581 cloud white		
	8/69 -	041 black		
35	*361 847 131 B	Beading - Hinged quarter window		
		from Ch. No. 112 203 to 221 974	2	M 93: 361-364
		from Ch. No. 221 975 to 310 2500 000	2	361-364; M 93: 365-368
		from Ch. No. 311 2000 001	2	M 93: 361-368
	4/61 -	041 black		
-	311 847 135 A	Weatherstrip	1	311-314
		for hinged quarter window left		
		to Ch. No. 28 882		

-	311 847 136 A	Weatherstrip for hinged quarter window right to Ch. No. 28 882	1	311-314
36	361 847 137 A	Weatherstrip 1900 mm for hinged quarter window frame from Ch. No. 28 883 to 112 202	2	311-314
		from Ch. No. 112 203 to 221 974	2	311-314; M 93: 361-364
		from Ch. No. 221 975 to 315 220 883	2	311-314, 361-364; M 93: 315-318, 365-368
		from Ch. No. 316 000 001 to 316 500 000	2	361-364; M 93: 315-318, 365-368
		from Ch. No. 317 000 001 to 310 2500 000	2	361-364; M 93: 315-318, 365-368; M 234
		from Ch. No. 311 2000 001	2	M 93: 315-318, 361-368
37	311 847 145 B	Weatherstrip for hinged quarter window glass from Ch. No. 28 883 to 112 202	2	311-314
		from Ch. No. 112 203 to 221 974	2	311-314; M 93: 361-364
		from Ch. No. 221 975 to 315 220 883	2	311-314, 361-364; M 93: 315-318, 365-368
		from Ch. No. 316 000 001 to 316 500 000	2	361-364; M 93: 315-318, 365-368
		from Ch. No. 317 000 001 to 310 2500 000	2	361-364; M 93: 315-318, 365-368; M 234
		from Ch. No. 311 2000 001	2	M 93: 315-318, 361-368
-	311 847 145 C	Weatherstrip, left for hinged quarter window glass from Ch. No. 316 000 001 to 310 2500 000	1	311-314
		from Ch. No. 311 2000 001	1	M 93: 311-314
38	311 847 146 C	Weatherstrip, right for hinged quarter window glass from Ch. No. 316 000 001 to 310 2500 000	1	311-314
		from Ch. No. 311 2000 001	1	M 93: 311-314
-	311 847 147 A	Frame - Weatherstrip, left from Ch. No. 316 000 001 to 310 2500 000	1	311-314
		from Ch. No. 311 2000 001	1	M 93: 311-314
39	311 847 148 A	Frame - Weatherstrip, right from Ch. No. 316 000 001 to 310 2500 000	1	311-314
		from Ch. No. 311 2000 001	1	M 93: 311-314
40	N 11 114 1	Nut, hex. BM 4 from Ch. No. 316 000 001 to 310 2500 000	8	311-314
		from Ch. No. 311 2000 001	8	M 93: 311-314
41	311 847 157	Cap, inner for hinged quarter window from Ch. No. 316 000 001 to 310 2500 000	2	311-314
		from Ch. No. 311 2000 001	2	M 93: 311-314

-	311 847 159 A	Cap, outer for hinged quarter window, left from Ch. No. 316 000 001 to 310 2500 000	1	311-314
		from Ch. No. 311 2000 001	1	M 93: 311-314
42	311 847 160 A	Cap, outer for hinged quarter window, right from Ch. No. 316 000 001 to 310 2500 000	1	311-314
		from Ch. No. 311 2000 001	1	M 93: 311-314
43	365 847 201	Plug for window fastener holes from Ch. No. 221 975	6	365-368
44	113 847 205	Gasket, outer - Pin to Ch. No. 112 202	2	311-314
		from Ch. No. 112 203 to 221 974	2	311-314; M 93: 361-364
		from Ch. No. 221 975 to 315 220 883	2	311-314, 361-364; M 93: 315-318, 365-368
		from Ch. No. 316 000 001 to 316 500 000	2	361-364; M 93: 315-318, 365-368
		from Ch. No. 317 000 001 to 310 2500 000	2	361-364; M 93: 315-318, 365-368; M 234
		from Ch. No. 311 2000 001	2	M 93: 315-318, 361-368
45	113 847 207	Gasket, inner - Pin to Ch. No. 112 202	2	311-314
		from Ch. No. 112 203 to 221 974	2	311-314; M 93: 361-364
		from Ch. No. 221 975 to 315 220 883	2	311-314, 361-364; M 93: 315-318, 365-368
		from Ch. No. 316 000 001 to 316 500 000	2	361-364; M 93: 315-318, 365-368
		from Ch. No. 317 000 001 to 310 2500 000	2	361-364; M 93: 315-318, 365-368; M 234
		from Ch. No. 311 2000 001	2	M 93: 315-318, 361-368
46	311 847 229	Pin - Fastener mounting to Ch. No. 112 202	2	311-314
		from Ch. No. 112 203 to 221 974	2	311-314; M 93: 361-364
		from Ch. No. 221 975 to 315 220 883	2	311-314, 361-364; M 93: 315-318, 365-368
		from Ch. No. 316 000 001 to 316 500 000	2	361-364; M 93: 315-318, 365-368
		from Ch. No. 317 000 001 to 310 2500 000	2	361-364; M 93: 315-318, 365-368; M 234
		from Ch. No. 311 2000 001	2	M 93: 315-318, 361-368

47	N 12 325 1	Lock washer 4		
		to Ch. No. 112 202	2	311-314
		from Ch. No. 112 203 to 221 974	2	311-314; M 93: 361-364
		from Ch. No. 221 975 to 315 220 883	2	311-314, 361-364; M 93: 315-318, 365-368
		from Ch. No. 316 000 001 to 316 500 000	2	361-364; M 93: 315-318, 365-368
		from Ch. No. 317 000 001 to 310 2500 000	2	361-364; M 93: 315-318, 365-368; M 234
		from Ch. No. 311 2000 001	2	M 93: 315-318, 361-368
-	311 847 245	Knob, silver beige		
		for fastener		
		to Ch. No. 112 202	2	311-314
		from Ch. No. 112 203 to 221 974	2	311-314; M 93: 361-364
		from Ch. No. 221 975 to 315 220 883	2	311-314, 361-364; M 93: 315-318, 365-368
		from Ch. No. 311 2000 001	2	M 93: 315-318
-	N 13 074 1	Stud M 3 x 5		
		to Ch. No. 112 202	2	311-314
		from Ch. No. 112 203 to 221 974	2	311-314; M 93: 361-364
		from Ch. No. 221 975 to 315 220 883	2	311-314, 361-364; M 93: 315-318, 365-368
48	361 847 247	Knob, chrome		
		for fastener		
		from Ch. No. 316 000 001 to 316 500 000	2	361-364; M 93: 315-318, 365-368
		from Ch. No. 317 000 001 to 310 2500 000	2	361-364; M 93: 315-318, 365-368; M 234
49	N 10 778 1	Screw, fillister hd. M 3 x 3.5		
		from Ch. No. 316 000 001 to 316 500 000	2	361-364; M 93: 315-318, 365-368
		from Ch. No. 317 000 001 to 310 2500 000	2	361-364; M 93: 315-318, 365-368; M 234
		from Ch. No. 311 2000 001	2	M 93: 315-318
50	311 847 285	Pin		
		for fastener mounting		
		from Ch. No. 316 000 001 to 310 2500 000	2	311-314
		from Ch. No. 311 2000 001	2	M 93: 311-314, 361-368
51	311 847 287	Gasket, outer - Pin		
		from Ch. No. 316 000 001 to 310 2500 000	2	311-314
		from Ch. No. 311 2000 001	2	M 93: 311-314, 361-368
52	311 847 291	Gasket, inner - Pin		
		from Ch. No. 316 000 001 to 310 2500 000	2	311-314
		from Ch. No. 311 2000 001	2	M 93: 311-314, 361-368
53	N 14 275 1	Screw, csk. raised hd. AM 6 x 10		
		from Ch. No. 316 000 001 to 310 2500 000	2	311-314
		from Ch. No. 311 2000 001	2	M 93: 311-314, 361-368





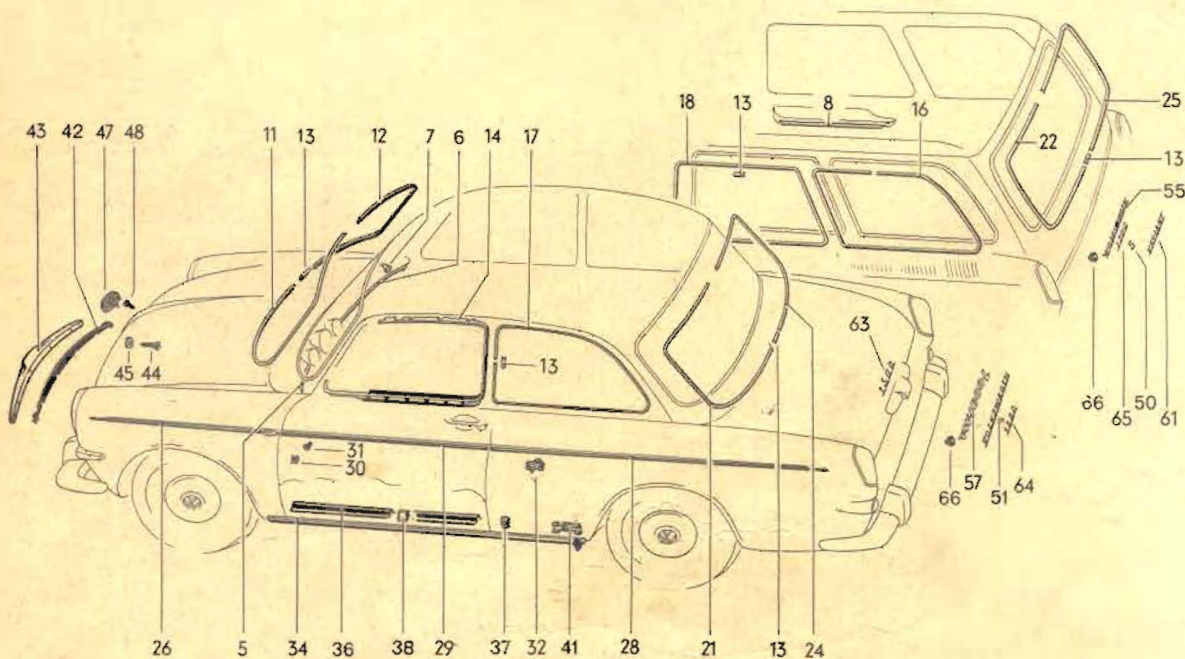
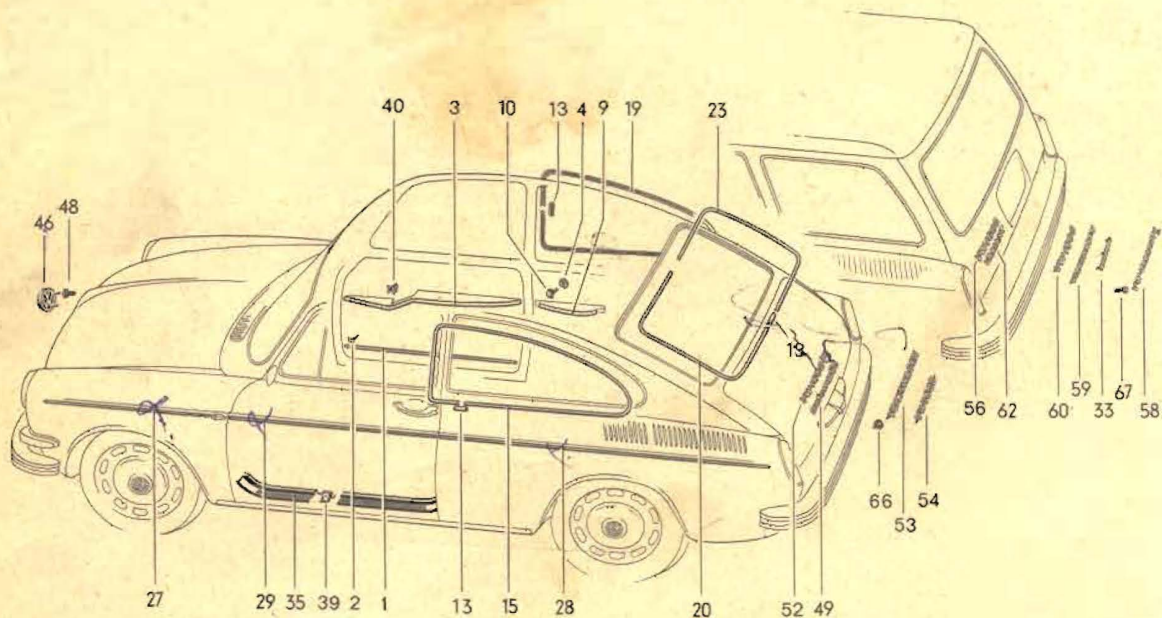

**MAIN GROUP 8**

**BODY**

Key	Part No.	Description	Qty.	Type and model
<b>MOLDINGS</b>				
1	311 853 053	Molding for door trim panel from Ch. No. 316 000 001 to 316 500 000	2	311-314, 361-364
2	221 853 149	Clamp - Molding from Ch. No. 316 000 001	24	311-314, 361-364
-	311 853 145	Molding for arm rest for door left from Ch. No. 316 000 001 to 318 149 518	1	311-314, 361-364; M 234; M 297
3	311 853 146	Molding for arm rest for door right from Ch. No. 316 000 001 to 318 149 518	1	311-314, 361-364; M 234; M 297
4	311 853 147	Clamping plate 4 for trim molding - Arm rest, quarter panel from Ch. No. 316 000 001 to 318 149 518	10	311-314; M 234; M 297
5	311 853 191 A	Molding, left - Instrument panel	1	311, 313, 315, 317, 361, 363, 365, 367
-	312 853 191 A	Molding, left - Instrument panel	1	312, 314, 316, 318, 362, 364, 366, 368
6	311 853 192 A	Molding, right - Instrument panel	1	311, 313, 315, 317, 361, 363, 365, 367
-	312 853 192 A	Molding, right - Instrument panel	1	312, 314, 316, 318, 362, 364, 366, 368
7	311 853 197 A	Retaining clip - Molding	7	311-318, 361-368
-	361 853 271	Trim molding for arm rest for quarter panel left from Ch. No. 366 000 001 to 367 500 000	1	361-364
8	361 853 272	Trim molding for arm rest for quarter panel right from Ch. No. 366 000 001 to 367 500 000	1	361-364
9	311 853 273	Molding for arm rest, quarter panel from Ch. No. 316 000 001 to 318 149 518	2	311-314; M 234; M 297
10	311 853 275	Bolt for trim moulding for arm rest, quarter panel from Ch. No. 316 000 001 to 318 149 518	10	311-314; M 234; M 297
11	315 853 305	Trim frame, left half for windshield use 315 853 306/309/311 845 121 B to Ch. No. 221 974	1	
12	315 853 306	Trim frame, right half for windshield use 315 853 305/309/311 845 121 B to Ch. No. 221 974	1	

-	311 853 309	Sleeve - Trim molding to Ch. No. 221 974	4	
13	315 853 309	Sleeve - Trim molding	4	311-314
			6	315-318, 361-364
			8	365-368
14	315 853 321 A	Trim frame, left for door window	1	
-	315 853 322 A	Trim frame, right for door window	1	
15	311 853 345	Trim frame for hinged quarter window left from Ch. No. 316 000 001 to 310 2500 000	1	311-314
		from Ch. No. 311 2000 001	1	M 93: 311-314
-	361 853 345	Trim frame for quarter window, rear, left to Ch. No. 221 974	1	361-364
16	365 853 345	Trim frame for quarter window, rear, left from Ch. No. 221 975	1	361-368
-	311 853 346	Trim frame for hinged quarter window right from Ch. No. 316 000 001 to 310 2500 000	1	311-314
		from Ch. No. 311 2000 001	1	M 93: 311-314
-	361 853 346	Trim frame for quarter window, rear, right to Ch. No. 221 974	1	361-364
-	365 853 346	Trim frame for quarter window, rear, right from Ch. No. 221 975	1	361-368
-	311 853 347	Trim frame for quarter window, left from Ch. No. 319 000 001 to 310 2500 000	1	M 233
		from Ch. No. 311 2000 001	1	311-314
17	315 853 347	Trim frame for quarter window, left from Ch. No. 221 975	1	315-318
-	361 853 347	Trim frame for quarter window, front, left to Ch. No. 221 974	1	361-364
18	365 853 347	Trim frame for quarter window, front, left from Ch. No. 221 975 to 310 2500 000	1	365-368
		from Ch. No. 311 2000 001	1	361-364
19	311 853 348	Trim frame for quarter window, right from Ch. No. 319 000 001 to 310 2500 000	1	M 233
		from Ch. No. 311 2000 001	1	311-314

-	315 853 348	Trim frame for quarter window, right from Ch. No. 221 975	1	315-318
-	361 853 348	Trim frame for quarter window, front, right to Ch. No. 221 974	1	361-364
-	365 853 348	Trim frame for quarter window, front, right from Ch. No. 221 975 to 310 2500 000 from Ch. No. 311 2000 001	1 1	365-368 361-364
-	361 853 349	Sleeve - Trim frame to Ch. No. 221 974	4	361-364
-	311 853 355	Trim frame, left half for rear window to Ch. No. 221 974	1	311-314
20	311 853 355 A	Trim frame, left half for rear window from Ch. No. 316 000 001	1 1	311-314 311-314
21	315 853 355	Trim frame, left half for rear window from Ch. No. 221 975 to 315 220 883 from Ch. No. 316 000 001	1 1	311-318 315-318
-	361 853 355	Trim frame, left half for rear window to Ch. No. 221 974	1	361-364
22	365 853 355	Trim frame, left half for rear window from Ch. No. 221 975	1	361-368
-	311 853 356	Trim frame, right half for rear window to Ch. No. 221 974	1	311-314
23	311 853 356 A	Trim frame, right half for rear window from Ch. No. 316 000 001	1 1	311-314 311-314
24	315 853 356	Trim frame, right half for rear window from Ch. No. 221 975 to 315 220 883 from Ch. No. 316 000 001	1 1	311-318 315-318
25	365 853 356	Trim frame, right half for rear window use 365 853 355 and 2 of 315 853 309 to Ch. No. 221 974	1	361-368
-	311 853 507 B	Molding for fender, front from Ch. No. 221 975 to 316 500 000	2	311-314, 361-364

-	*311 853 507 C	Molding for fender, front, less parking lamp from Ch. No. 221 975 to 316 500 000	2	M 297; M 237
26	311 853 507 D	Molding for fender, front from Ch. No. 317 000 001 to 319 500 000	2	311-314, 361-364; M 234
-	*311 853 507 E	Molding for fender, front, less parking lamp from Ch. No. 317 000 001 to 319 500 000	2	M 297; M 237; M 239
27	311 853 507 E	Molding for front fender with parking lamp from Ch. No. 310 2000 001	2	311-314, 361-364; M 234
-	311 853 507 F	Molding for front fender without parking lamp from Ch. No. 310 2000 001	2	M 297; M 237; M 239
-	*311 853 509 A	Molding for fender, rear from Ch. No. 221 975 to 316 500 000	2	311-314, 361-364; M 237
28	*311 853 509 B	Molding for fender, rear from Ch. No. 317 000 001	2	311-314, 361-364; M 234; M 237
-	*311 853 515 B	Molding - Door from Ch. No. 221 975 to 316 500 000	2	311-314, 361-364; M 237
29	*311 853 515 C	Molding - Door from Ch. No. 317 000 001	2	311-314, 361-364; M 234; M 237
30	*113 853 585 B	Retaining clip - Molding from Ch. No. 221 975 to 316 500 000	34	311-314, 361-364; M 237
31	*113 857 219 A	Seal - Molding retaining clip from Ch. No. 221 975 to 316 500 000	34	3qq-314, 361-364; M 237
32	*113 853 585 C	Plastic clip - Molding from Ch. No. 317 000 001	34	311-314, 361-364; M 234; M 237
33	361 853 551	Molding - Rear door from Ch. No. 316 000 001	1	M 273:365-368; M 297:361- M 242:365-368; M 239:361
-	311 853 555 A	Molding outer to Ch. No. 316 500 000	2	
34	311 853 555 B	Molding outer from Ch. No. 317 000 001	2	
35	311 853 557 A	Molding - Sill panel, left	1	311-314, 361-364; M 234
-	315 853 557	Molding - Sill panel from Ch. No. 221 975 to 317 500 000	2	315-318, 365-368
36	315 853 557 A	Molding - Sill panel from Ch. No. 318 000 001	2	315-318, 365-368; M 233
-	311 853 558 A	Molding - Sill panel, right	1	311-314, 361-364; M 234
37	411 853 575	Plastic clip for molding, outer from Ch. No. 316 080 004 to 318 500 000	10	

38	311 853 577	Clip - Sill panel molding ✓ to Ch. No. 315 019 300	8	
		from Ch. No. 316 000 001	8	315-318, 365-368; M 233
39	311 853 577 A	Clip - Sill panel molding from Ch. No. 315 019 301 to 315 220 883	8	
		from Ch. No. 316 000 001	8	311-314, 361-364; M 234
40	311 853 585	Clip for molding - Arm rest for door from Ch. No. 316 000 001 to 317 500 000	22	311-314, 361-364
41	311 853 587 A	Retaining clip - Molding outer from Ch. No. 317 000 001 to November 1970	14	
-	311 853 587 B	Plastic clip - Molding, outer from Ch. No. October 1970	14	
-	311 853 589	Retaining clip - Molding outer to Ch. No. 316 080 003	14	
		from Ch. No. 316 080 004 to 316 500 000		
-	311 853 591	Packing - Grip molding from Ch. No. 221 975 to 315 220 883	1	311-314, 361-364
		041 black		
		539 Baltic blue		
		563 safari beige		
		568 sea sand		
		575 nutria brown		
42	*311 853 591 C	Packing - Grip molding from Ch. No. 316 000 001 to 319 500 000	1	311-314, 361-364; M 234; M 237
		041 black		
		087 pearl white		
		282 lotus white		
		539 Baltic blue		
		568 sea sand		
		610 Delta green		
		620 savanna beige		
		630 cobalt blue		
		633 blue VW		
		650 Granada red		
		30 A royal red		
		50 B diamond blue		
		50 F regatta blue		
		60 B Peru green		
		66 B deep sea green		
		70 F chinchilla		
		90 C toga white		
43	*311 853 595 C	Grip molding - Hood front from Ch. No. 221 975 to 319 500 000	1	311-314, 361-364; M 234; M 237
44	N 14 140 5	Screw, fillister hd. AM 6 x 15	4	311-314, 361-364; M 234; M 237
45	N 12 226 2	Spring washer B 6	4	311-314, 361-364; M 234; M 237

46	311 853 601	VW sign, front from Ch. No. 310 2000 001	1
47	113 853 601 B	VW sign, front from Ch. No. 95 100 to 319 500 000	1
48	113 853 615	Seal - VW sign, front	3
-	311 853 675	Name "Automatic" from Ch. No. 318 015 226 to 318 500 000	1 M 249: 311-314; M 234/M 249: 315-318
49	311 853 675 A	Name "automatic" from Ch. No. 319 000 001	1 M 249: 311-314; M 234/M 249: 315-318
-	361 853 675	Name "Automatic" from Ch. No. 368 015 226 to 368 500 000	1 M 249: 361-364
-	411 853 675	Name "automatic" from Ch. No. 369 000 001	1 M 249: 361-364
-	361 853 677	Name "E" from Ch. No. 221 975 to 365 220 883	1 M 3: 361-364
50	361 853 679	Name "S" from Ch. No. 221 975 to 365 220 883	1 361-364
51	311 853 687	Name "Volkswagen" from Ch. No. 95 100 to 315 220 883	1 311-318
52	311 853 687 A	Name "VW 1600 TL" (for Germany only) from Ch. No. 316 000 001	1 311-314
53	311 853 687 C	Name "Volkswagen" from Ch. No. 316 000 001	1 M 14; M 297: 311-314
-	311 853 687 F	Name "VW 1600 TLE" (not for USA) from Ch. No. 319 000 001	1 M 236: 311-314
54	311 853 687 G	Name "VW 1600" from Ch. No. 319 000 001	1 M 233: 311-314
-	311 953 687 H	Name "VW 1600 E" from Ch. No. 311 2000 001	1 M 233/M 236: 311-314; M 233/M 236/M 249: 311-314
-	315 853 687	Name "VW 1600 L"	1 M 234/M 249: 315-318
-	315 853 687 B	Name "VW 1600 LE" from Ch. No. 318 015 226 to 319 500 000 (not for USA) from Ch. No. 319 000 001 to 319 500 000	1 M 236/M 249/M 234
55	361 853 687	Name "Volkswagen" from Ch. No. 366 000 001 to 369 500 000	1 361-368
56	361 853 687 A	Name "VW 1600" (for Germany only) from Ch. No. 366 000 001 to 366 500 000 from Ch. No. 317 000 001	1 361-364 1 315-318, 365-368
-	361 853 687 B	Name "Volkswagen" from Ch. No. 316 000 001 to 319 500 000	1 M 14, M 273, M 297
57	361 853 687 D	Name "VW 1600 L" from Ch. No. 317 000 001	1 M 234



58	361 853 687 G	Name "VW Variant L" (not for USA) from Ch. No. 360 2000 001	1	361-364
-	361 853 687 H	Name "VW Variant LE" (not for USA) from Ch. No. 360 2000 001	1	M 236: 361-364
59	361 853 687 J	Name "Volkswagen" (for export only) from Ch. No. 310 2000 001	1	M 3, M 14, M 297, M 239: 361-368
-	361 853 687 F	Name "VW 1600 LE" (not for USA) from Ch. No. 319 000 001 to 319 500 000	1	M 236/M 234: 315-318; M 236: 361-364
		from Ch. No. 310 2000 001	1	M 236/M 239: 315-318
60	365 853 687	Name "VW 1500" (for Germany only) from Ch. No. 316 000 001 to 316 500 000	1	315-318, 365-368
-	365 853 687 A	Name "VW Variant" from Ch. No. 360 2000 001	1	365-368
-	365 853 687 C	Name "VW Variant E" from Ch. No. 361 2000 001	1	M 236: 365-368; M 236/M 249: 365-368
61	361 853 689	Name "Variant" (for Germany only) to Ch. No. 365 220 883	1	361-368
62	361 853 689 A	Name "Variant" from Ch. No. 366 000 001 to 369 500 000	1	361-368
63	311 853 691	Name "1500" to Ch. No. 95 099	1	311-314
64	361 853 691 A	Name "1500" from Ch. No. 95 100 to 315 220 883	1	311-318
65	361 853 691 A	Name "1500" (for export only) to Ch. No. 365 220 883	1	361-368
66	131 853 695	Clamping plate 15 x 2	X	
67	113 853 615	Seal - Name from Ch. No. 360 2000 001	3	361-368

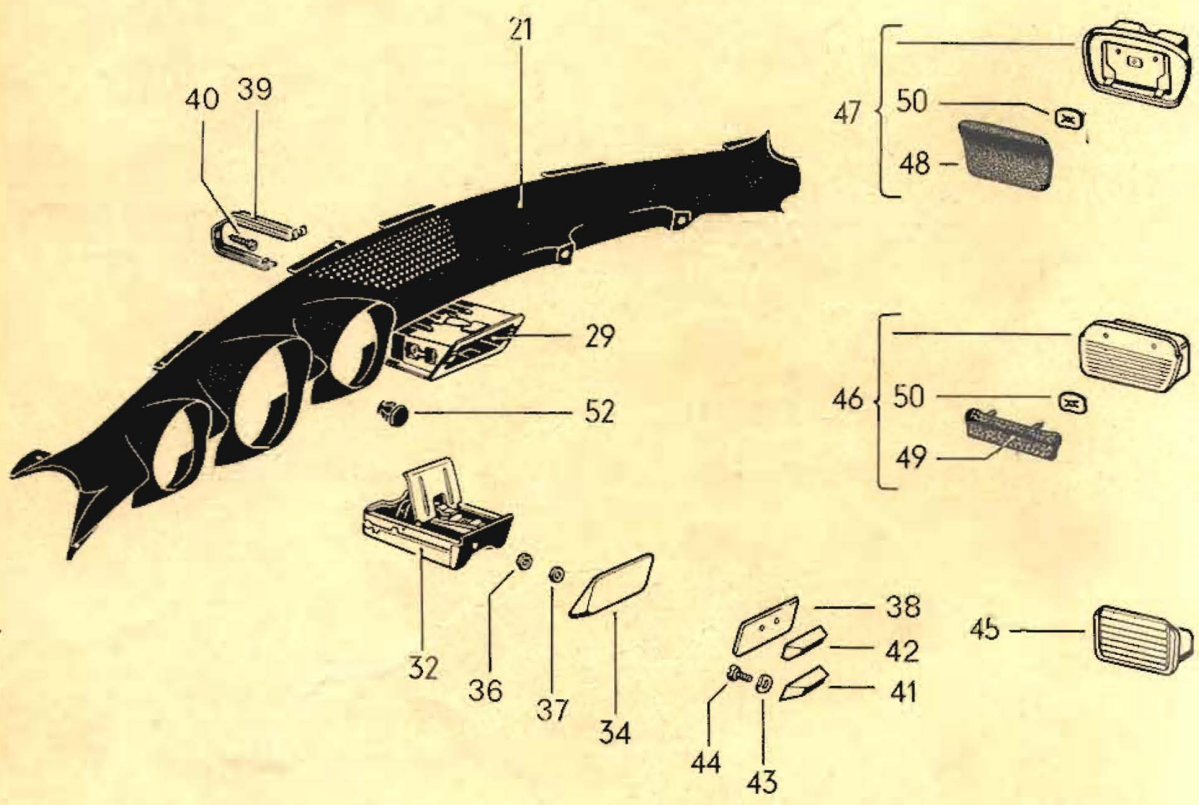
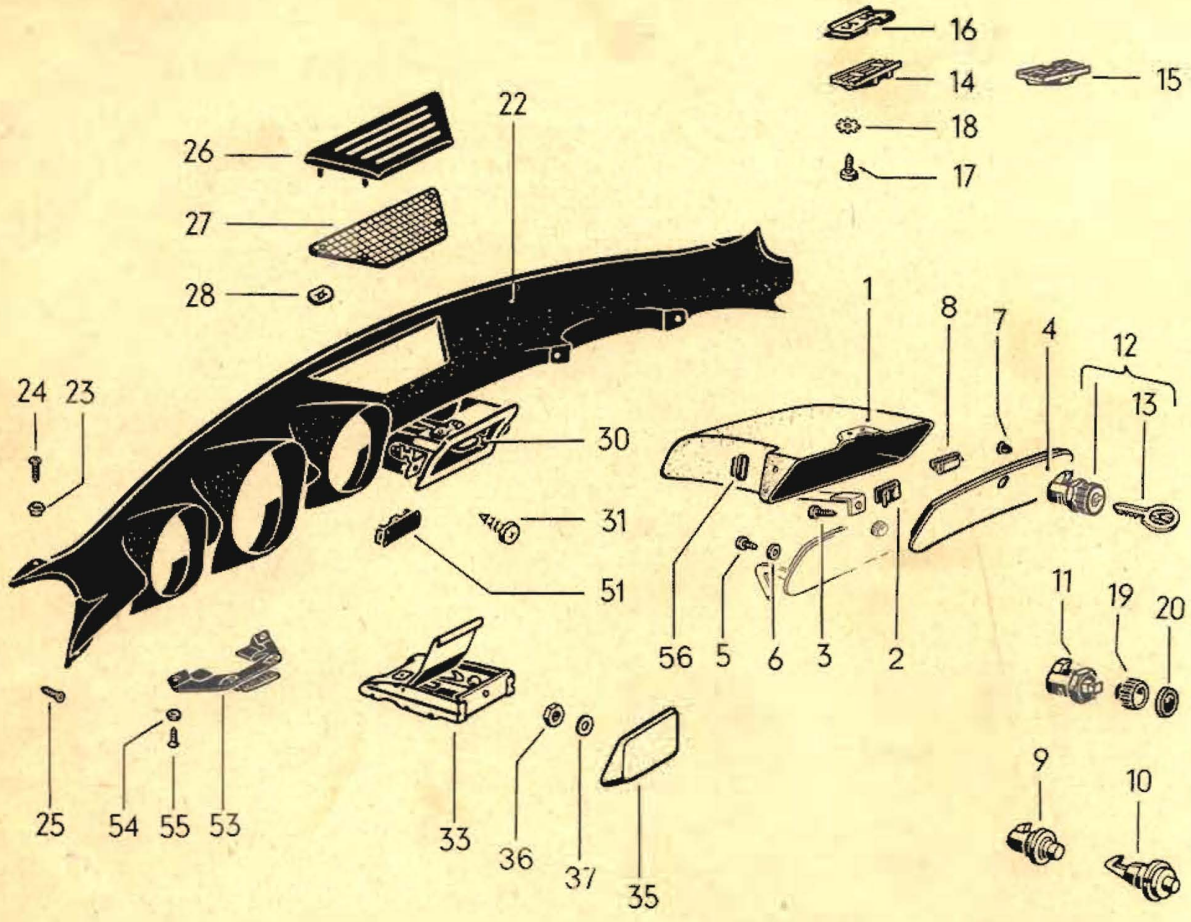

**MAIN GROUP 8**

**BODY**

Key	Part No.	Description	Qty.	Type and model
<b>INSTRUMENT PANEL FITTINGS</b>				
<b>ASHTRAY</b>				
-	311 857 051 B	Instrument panel cover to Ch. No. 315 220 883	1	311, 313, 361, 363
-	315 857 051 A	Instrument panel cover from Ch. No. 316 000 001 to 316 140 226	1	311, 313, 315, 317, 361, 363, 365, 367
	8/65 - 12/65	651 pigalle - 79		
	8/65 - 12/65	671 Teak - 51		
-	316 857 051 A	Instrument panel cover from Ch. No. 316 000 001 to 316 140 226	1	312, 314, 316, 318, 362, 364, 366, 368
	8/65 - 12/65	651 pigalle - 79		
	8/65 - 12/65	671 Teak - 51		
-	311 857 101	Glove compartment to Ch. No. 318 500 000	1	311, 313, 315, 317, 361, 363, 365, 367
1	311 857 101 B	Glove compartment from Ch. No. 319 000 001	1	311, 313, 315, 317, 361, 363, 365, 367
-	312 857 101	Glove compartment to Ch. No. 318 500 000	1	312, 314, 316, 318, 362, 364, 366, 368
-	312 857 101 B	Glove compartment from Ch. No. 319 000 001 to 310 2500 000	1	312, 314, 316, 318, 362, 364, 366, 368
-	312 857 101 D	Glove compartment from Ch. No. 311 2000 001	1	312, 314, 316, 318, 362, 364, 366, 368
2	N 15 421 1	Speed nut B 4.8	1	
3	N 13 971 1	Tapping screw, fillister hd. B 4.8x22	1	
-	311 857 121 A	Lid - Glove compartment to Ch. No. 317 500 000	1	311, 313, 315, 317, 361, 363, 365, 367
4	311 857 121 C	Lid - Glove compartment from Ch. No. 318 000 001	1	311, 313, 315, 317, 361, 363, 365, 367
-	312 857 121 A	Lid - Glove compartment to Ch. No. 317 500 000	1	312, 314, 316, 318, 362, 364, 366, 368
-	312 857 121 C	Lid - Glove compartment from Ch. No. 318 000 001	1	312, 314, 316, 318, 362, 364, 366, 368
5	N 14 127 4	Screw, fillister hd. AM 5x6	4	
6	N 12 225 1	Spring washer B 5	4	
7	111 857 145 A	Rubber stop - Glove compartment lid	2	
8	111 857 119	Clamp - Glove compartment from Ch. No. 318 000 001	1	
9	311 857 131 A	Lock - Glove compartment lid to Ch. No. 174 772	1	
10	111 857 131	Lock - Glove compartment lid from Ch. No. 174 773 to 317 500 000	1	
11	111 857 131 C	Lock - Glove compartment lid from Ch. No. 318 000 001 to 310 2500 000	1	
		from Ch. No. 311 2000 001	1	315-318, 365-368

12	113 857 131	Lock with keys for glove compartment lid from Ch. No. 318 000 001 to 310 2500 000 from Ch. No. 311 2000 001	1 1	M 54 311-314,361-364;M 54:M 233
13	111 837 219 A	Key for lock (specify key number) from Ch. No. 318 000 001 to 310 2500 000 from Ch. No. 311 2000 001 S73 Profile SC S74 Profile SU S75 Profile SV	2 2	M 54 311-314, 361-364; M 54;M 233
14	311 857 133	Striker plate - Glove compartment lid to Ch. No. 174 772	1	
15	311 857 133 A	Striker plate - Glove compartment lid from Ch. No. 174 773 to 317 500 000	1	
16	311 857 169	Speed nut - Striker plate to Ch. No. 317 590 000	1	
17	N 13 967 1	Tapping screw, fillister hd. B 4.2x19	2	
18	N 12 121 2	Shake-proof washer A 4.3	2	
19	113 819 661 C	Knob for glove compartment lid lock from Ch. No. 318 000 001 to 310 2500 000 from Ch. No. 311 2000 001	1 1	315-318,365-368
20	111 857 499	Cap - Knob for glove compartment lid lock from Ch. No. 318 000 001 to 310 2500 000 from Ch. No. 311 2000 001	1 1	315-318, 365-368
-	311 857 205 A	Instrument panel cover to Ch. No. 315 220 883	1	311, 313, 361, 363
21	311 857 205 C	Instrument panel cover to Ch. No. 315 220 883 from Ch. No. 316 000 001 to 310 2500 000 use 311 857 641 B (041) to Ch. No. 317 500 000	1 1	315, 317, 365, 367 311, 313, 315, 317, 361, 363, 365, 367
	8/63 - 7/70	041 black		
22	311 857 205 E	Instrument panel cover from Ch. No. 311 2000 001	1	311, 313, 315, 317, 361, 363, 365, 367
-	312 857 205 A	Instrument panel cover to Ch. No. 315 220 883	1	312, 314, 362, 364
-	312 857 205 C	Instrument panel cover to Ch. No. 315 220 883 from Ch. No. 316 000 001 to 310 2500 000 use 311 857 641 B (041) to Ch. No. 317 500 000	1 1	316, 318, 366, 368 312, 314, 316, 318, 362, 364, 366, 368
	8/63 - 7/70	041 black		
-	312 857 205 E	Instrument panel cover from Ch. No. 311 2000 001	1	312, 314, 316, 318, 362, 364, 366, 368

23	311 857 197	*Concave washer for instrument panel cover to Ch. No. 310 2500 000	7	
		from Ch. No. 311 2000 001	2	
24	N 14 087 3	Tapping screw, csk. raised hd. B 3.5x16 to Ch. No. 310 2500 000	7	
		from Ch. No. 311 2000 001	2	
25	111 837 445	*Tapping screw, csk. hd. 3.5x13 for instrument panel cover	7	
26	311 857 209 B	Grille for loudspeaker from Ch. No. 311 2000 001	1	
27	311 857 229	Packing for loudspeaker grille from Ch. No. 311 2000 001	1	
28	113 857 113	*Clamping plate from Ch. No. 311 2000 001	4	
29	311 857 305 C	Housing - Ashtray to Ch. No. 310 2500 000	1	
30	311 857 305 D	Housing - Ashtray from Ch. No. 311 2000 001	1	
31	N 13 968 1	Tapping screw, fillister hd. B 4.8	2	
32	311 857 309 B	Insert - Ashtray to Ch. No. 310 2500 000 use 311 857 339 A to Ch. No. 316 500 000	1	
33	311 857 311 C	Insert - Ashtray from Ch. No. 311 2000 001	1	
34	311 857 339 A	Cover - Ashtray insert from Ch. No. 317 000 001 to 310 2500 000	1	
35	311 857 339 B	Cover - Ashtray insert from Ch. No. 311 2000 001	1	
36	N 12 225 1	Spring washer B 5	1	
37	N 11 005 2	Nut, hex. M 5	1	
38	311 857 351	Cover - Ashtray insert to Ch. No. 316 500 000	1	
39	311 857 371	Bracket - Ashtray housing to Ch. No. 310 2500 000	1	
40	N 13 971 1	Tapping screw, csk. raised hd. B 4.8x22	1	
41	311 857 375	Pull - Ashtray to Ch. No. 239 748	1	
42	311 857 377 C	Pull - Ashtray from Ch. No. 239 749 to 316 500 000	1	
43	N 12 224 1	Spring washer B 4	2	
44	N 10 698 1	Screw, cheese hd. AM 4x12	2	
45	113 857 405 C	Ashtray - Quarter panel, right from Ch. No. 221 975 to 317 500 000	1	315-318, 365-368

46	311 857 405 A	Ashtray – Quarter panel to Ch. No. 317 500 000	2	311-314, 361-364
	4/61 – 7/67	043 grey-black		
47	311 857 405 B	Ashtray – Quarter panel from Ch. No. 318 000 001	2	311-314, 361-364
	8/67 –	043 grey-black	1	315-318, 365-368
48	311 857 431 A	Cover – Ashtray from Ch. No. 318 000 001	2	311-314, 361-364
	8/67 –	043 grey-black	1	315-318, 365-368
49	311 857 445 B	Pull – Ashtray from Ch. No. 317 000 001 to 317 500 000	2	311-314, 361-364
	8/66 – 7/67	043 grey-black		
50	113 857 113	Clamping plate	4	311-314, 361-364
51	311 857 469	Cap – Switch opening (heatable rear window) to Ch. No. 311 2129 850	1	
–	113 959 623	Cap – Switch opening (heatable rear window) to Ch. No. 311 2129 851	1	
52	113 857 489	Plug – Switch opening 14 mm dia. (heater booster switch)	1	
–	113 857 490	Plug – Switch opening 10 mm dia. (fresh air fan switch)	1	
–	113 857 490 A	Plug – Switch opening 20 mm dia. (dual circuit brake warning light)	1	
53	311 857 491	Cap – Steering column tube from Ch. No. 318 000 001 to 311 2500 000	1	311, 313, 315, 317, 361, 363, 365, 367
–	311 857 491 B	Cap for steering column tube, upper part from Ch. No. 312 2000 001	1	311, 313, 315, 317, 361, 363, 365, 367
–	312 857 491	Cap – Steering column tube from Ch. No. 318 000 001 to 311 2500 000	1	312, 314, 316, 318, 362, 364, 366, 368
–	312 857 491 B	Cap for steering column tube, upper part from Ch. No. 312 2000 001	1	312, 314, 316, 318, 362, 364, 366, 368,
54	N 11 521 1	Washer A 3.7	2	
55	N 13 961 2	Tapping screw, fillister hd. B 3.9x13	2	
56	311 857 495	Escutcheon for hood release mechanism from Ch. No. 319 000 001	1	
–	311 857 497	Cap for steering column tube, lower part from Ch. No. 312 2000 001	1	
–	N 13 961 2	Tapping screw, fillister hd. B 3.9 x 13	2	
–	N 13 957 2	Tapping screw, fillister hd. B 3.5 x 9.5	1	
–	N 11 522 2	Washer A 4.3	1	



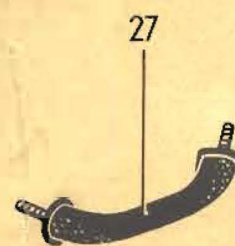
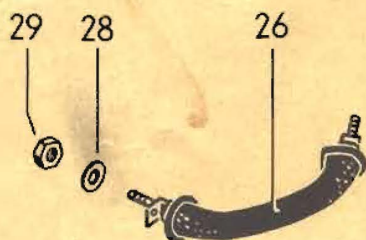
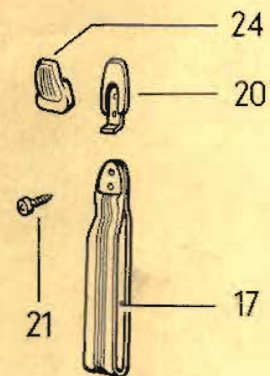
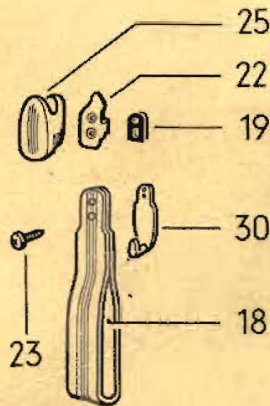
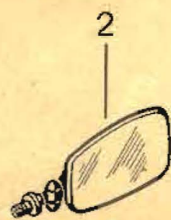
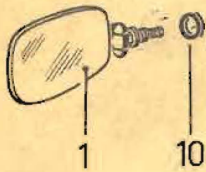
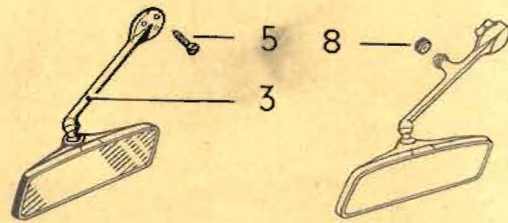
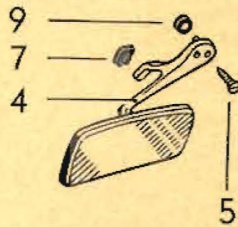
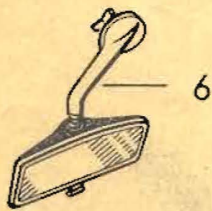
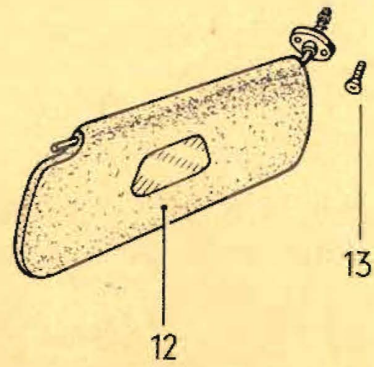
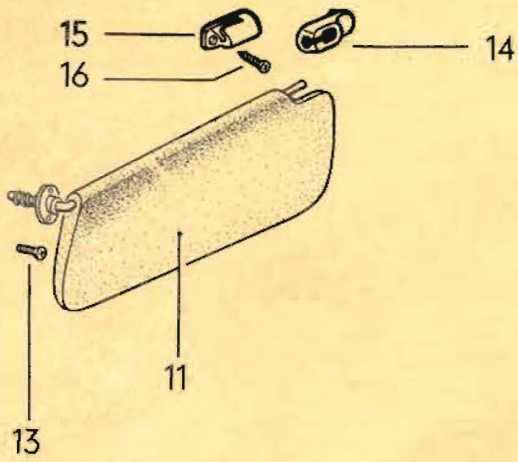



**MAIN GROUP 8**

**BODY**

Key	Part No.	Description	Qty.	Type and model
<b>REAR VIEW MIRROR</b>				
<b>SUN VIZOR . GRAB HANDLES</b>				
1	311 857 501 C	Rear view mirror, outer, left	1	311,313,315,317, 361,363,365,367
-	311 857 501 D	Rear view mirror, outer, left from Ch. No. June 1971	1	M 124: 311, 313, 315, 317, 361, 363, 365, 367
-	362 857 501 B	Rear view mirror, outer, left	1	362, 364
2	361 857 502 B	Rear view mirror, outer, right	1	312, 314, 316, 318, 361-364, 366, 368
-	361 857 502 D	Rear view mirror, outer, right (Convex)	1	M 62: 311, 313, 315, 317 361, 363, 365, 367; M 528: 361, 363, 365, 367
-	361 857 502 F	Rear view mirror, outer, right from Ch. No. June 1971	1	M 124: 361, 363, 365, 367
3	311 857 507 F	Rear view mirror, inner to Ch. No. 315 220 883	1	311-318
4	361 857 507	Rear view mirror, inner to Ch. No. 365 220 883	1	361-368
5	N 14 267 5	Screw, csk. raised hd. AM 5x18	2	
6	311 857 511	Rear view mirror, inner, anti-dazzle from Ch. No. 316 000 001	1	311-318
-	311 857 511 A	Rear view mirror, inner, anti-dazzle from Ch. No. June 1971	1	M 124
7	361 857 513	Rubber buffer - Rear view mirror, inner to Ch. No. 365 220 883	1	361-368
8	361 857 513 A	Rubber buffer - Rear view mirror from Ch. No. 366 000 001 to 368 500 000	1	361-368
9	361 857 515	Rubber ring - Rear view mirror, inner to Ch. No. 365 220 883	1	361-368
10	311 857 543	Rubber packing - Rear view mirror, outer	1	
-	311 857 551	Sun vizor to Ch. No. 483 592	2	311-314, 361-364
	4/61 - 7/64	466 silver beige	1	315-318, 365-368
11	311 857 551 C	Sun vizor from Ch. No. 315 000 001 to 310 2500 000	2	311-314, 361-364
		from Ch. No. 315 000 001	1	315-318, 365-368
		from Ch. No. 311 2000 001	1	311-314, 361-364
	8/64 -	581 cloud white		
-	312 857 551 A	Sun vizor, left with mirror from Ch. No. 311 2000 001	1	312, 314, 362, 364; M 234: 316, 318;
	8/70 -	581 cloud white		M 282: 316, 318, 366, 368; M 282 / M 233: 312, 314

12	311 857 552 E	Sun vizor, right with mirror from Ch. No. 311 2000 001 8/70 - 581 cloud white	1	311,313,361,363; M 234: 315, 317; M 282: 315,317, 365, 367; M 282/M 233: 311,313
13	N 14 094 2	Tapping screw, raised hd. B 4.2x16	4	311-314, 361-364
			2	315-318, 365-368
14	311 857 561	Retainer - Sun vizor to Ch. No. 317 080 000 4/61 - 7/64 466 silver beige 8/64 - 10/66 581 cloud white	2	311-314, 361-364
			1	315-318, 365-368
15	111 857 561 B	Retainer - Sun vizor, left from Ch. No. 317 080 001 10/66 - 581 cloud white	1	311-314, 315, 317, 361-364, 365-367; M 234: 315, 317
-	111 857 562 A	Retainer - Sun vizor, right from Ch. No. 317 080 001 10/66 - 581 cloud white	1	311-314, 316, 318, 361-364, 366, 368; M 234: 316, 318
16	N 13 961 2	Tapping screw, fillister hd. B 3.9x13	2	
-	311 857 569 B	Distance piece - Rear view mirror from Ch. No. 316 000 001 to 316 500 000	2	
17	311 857 611	Assist strap to Ch. No. 317 080 000 4/61 - 7/64 466 silver beige 8/64 - 9/66 581 cloud white	2	
-	113 857 611 C	Assist strap from Ch. No. 317 080 001 to 317 500 000 10/66 - 7/67 581 cloud white	2	
18	113 857 611 D	Assist strap from Ch. No. 318 000 001 8/67 - 581 cloud white	2	
19	113 857 639 A	Rubber packing - Assist strap from Ch. No. 318 000 001	2	
20	311 857 635 A	Coat hook to Ch. No. 317 080 000	2	
21	N 14 125 1	Screw, csk. hd. AM 4x18	4	
22	113 857 635 C	Coat hook from Ch. No. 317 080 001 use: from Ch. No. 317 080 001 to 317 500 000 113 857 611 D/637 B/639 A	2	
23	N 14 001 1	Tapping screw, csk. hd. B 4.8x25	4	
24	311 857 637 A	Coat hook molding to Ch. No. 317 080 000 4/61 - 7/64 466 silver beige 8/64 - 9/66 581 cloud white	2	

25	113 857 637 B	Coat hook molding from Ch. No. 317 080 001 use : from Ch. No. 317 080 001 to 317 500 000 113 857 611 D/635 C/639 A	2	
	8/67 -	581 cloud white		
26	311 857 641 A	Grab handle - Front seat passenger to Ch. No. 317 500 000	1	
	8/65 - 12/65	671 Teak - 51		
	8/65 - 12/65	651 pigalle - 79		
	4/61 - 7/67	041 black		
27	311 857 641 B	Grab handle - Front seat passenger from Ch. No. 318 000 001	1	
	8/67 -	041 black		
28	211 805 243	Spring washer 6.5x17	2	
29	N 11 006 2	Nut, hex. M 6	2	
30	113 857 723	Hook - Safety belt, front from Ch. No. 318 000 001	2	M 185

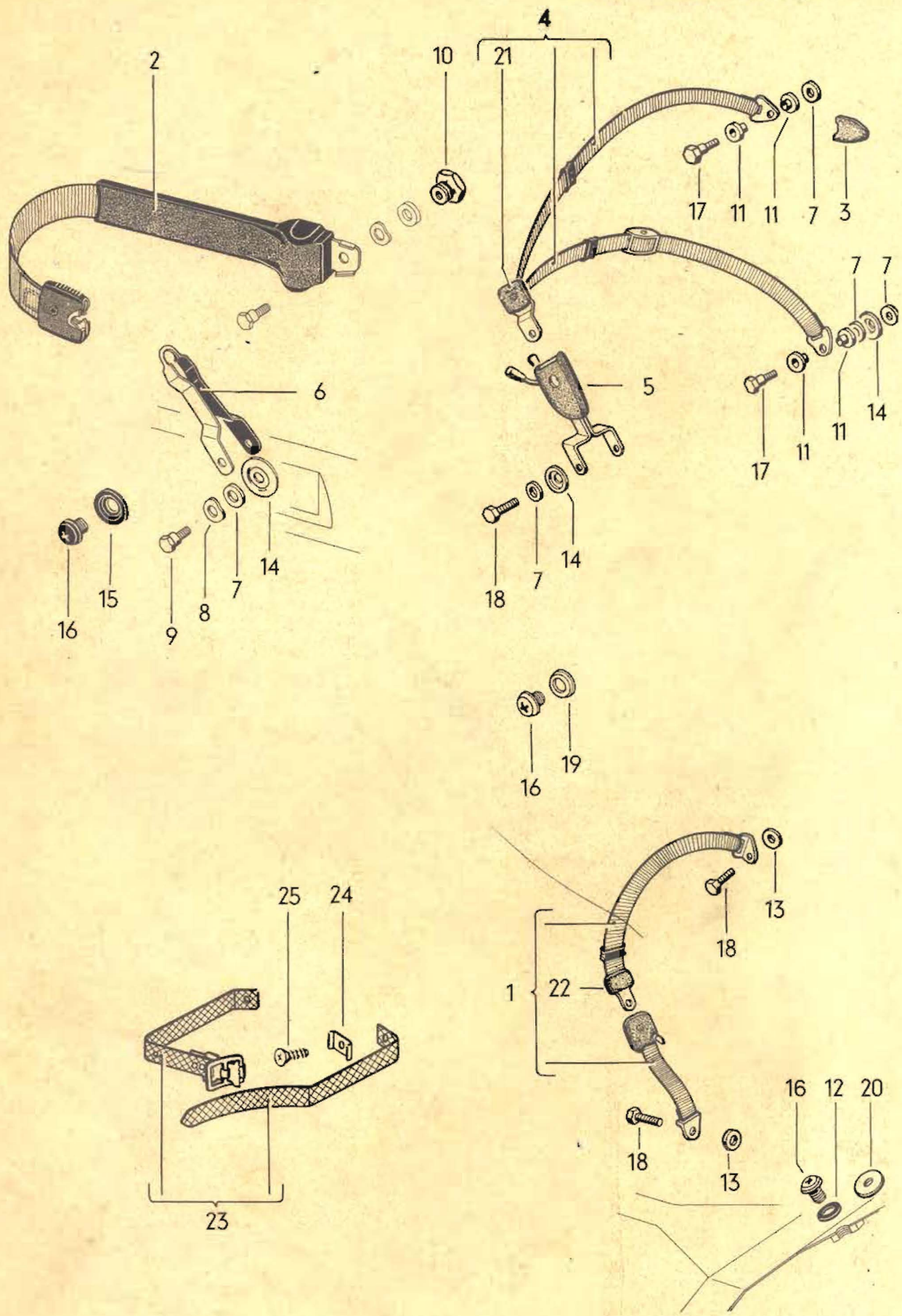

**MAIN GROUP 8**

**BODY**

Key	Part No.	Description	Qty.	Type and model
<b>SAFETY BELT</b>				
-	311 857 703 D	Lap belt, rear, left from Ch. No. 318 000 001	1	M 186
1	311 857 704 D	Lap belt, rear, right from Ch. No. 318 000 001	1	M 186
2	311 857 705	Lap belt retractor type from Ch. No. 317 000 001 to 317 500 000	2	M 27
3	111 857 719 C	Cap, upper for safety belt, front from Ch. No. 318 000 001	2	M 185
4	113 857 721 C	Three-point safety belt front from Ch. No. 318 000 001	2	M 185
-	113 857 723	Hook - Safety belt, front from Ch. No. 318 000 001 see illustration B 48	2	M 185
-	111 857 727	Retractor roller for three-point safety belt, front from Ch. No. 318 000 001	2	M 185
5	311 857 753	Belt lock for safety belt, front from Ch. No. 318 000 001	1	M 185
6	111 857 755	Tunnel fitting for lap belt mounting	1	
7	111 857 707	Spacer 11.5x30 - Lap belt and tunnel fitting mounting	X	
8	N 12 238 2	Spring washer B 16 Lap belt and tunnel fitting mounting	2	
9	111 857 757	Bolt, hex. hd. - Lap belt and tunnel fitting mounting	4	
10	311 857 761	Adapter bush M 24x1.5 to 7/16" - Safety belt mounting	X	
11	111 857 771 A	Shouldered washer from Ch. No. 318 000 001	8	M 185
12	311 857 779 A	Sealing ring 2 mm - Safety belt mounting on luggage compartment floor to Ch. No. 445 246	2	
13	111 857 779	Sealing ring 1.5 mm - Safety belt mounting on luggage compartment floor and floor plate from Ch. No. 445 247	6	
14	111 857 781	Washer - Tunnel fitting	2	

-	311 857 781	Escutcheon for safety belt mounting on frame to Ch. No. 445 246	2	
	4/61 - 5/64	469 anthracite		311-314, 361-364
	8/63 - 12/63	043 grey-black		315-318, 365-368
	1/64 - 5/64	469 anthracite		315-318, 365-368
-	111 857 781 A	Escutcheon for safety belt mounting on frame from Ch. No. 316 000 001 to 316 500 000	2	
	8/65 - 7/66	634 ultra blue - 54		
15	411 857 781	Escutcheon for safety belt mounting on frame from Ch. No. 445 247	2	
	6/64 -	043 grey black		
-	131 857 781	Escutcheon for safety belt mounting from Ch. No. 317 000 001 to 317 500 000	2	M 27
-	311 857 785	Cover bush for safety belt mounting to Ch. No. 445 246	8	
	4/61 - 5/64	466 silver beige		311-314, 361-364
	4/61 - 5/64	469 anthracite		311-314, 361-364
	8/63 - 12/63	043 grey-black		315-318, 365-368
	1/64 - 5/64	469 anthracite		315-318, 365-368
	8/63 - 5/64	466 silver beige		315-318, 365-368
16	111 857 785	Cover bush for safety belt mounting from Ch. No. 445 247	10	
	6/64 -	581 cloud white		
	8/66 -	043 grey-black		
17	111 857 793 C	Bolt, hex. hd. for safety belt, front from Ch. No. 318 000 001	4	M 185
18	111 857 799 A	Bolt, hex. hd. for tunnel belt lock from Ch. No. 318 000 001	2	M 185
			4	M 186
-	311 857 795	Escutcheon - Safety belt mounting on quarter panel and luggage compartment floor to Ch. No. 445 246	6	
	4/61 - 5/64	466 silver beige		
19	111 857 795	Escutcheon - Safety belt mounting on quarter panel and luggage compartment floor from Ch. No. 445 247	6	
	6/64 -	581 cloud white		

20	113 857 797 A	Escutcheon for safety belt mounting on floor plate from Ch. No. 445 247 to 316 500 000	2	M 259
	6/64 - 7/65	469 anthracite		
	8/65 - 7/66	046 lava - 50, 51, 54, 55, 78, 80, 83		
	8/65 - 7/66	652 scarlet - 79		
	8/65 - 7/66	662 almond beige - 81		
21	111 857 843	*Cap for seat belt buckle, front	2	M 185
22	111 857 845	*Cap for seat belt buckle, rear	2	M 186

**MOUNTING PARTS FOR FIRST AID KIT**

**M 82**

23	411 860 265	Retaining strap - First aid kit	1	
24	411 860 269	Cover - Retaining strap	2	
25	N 14 001 1	Tapping screw, csk. hd. B 4.8 x 25	2	

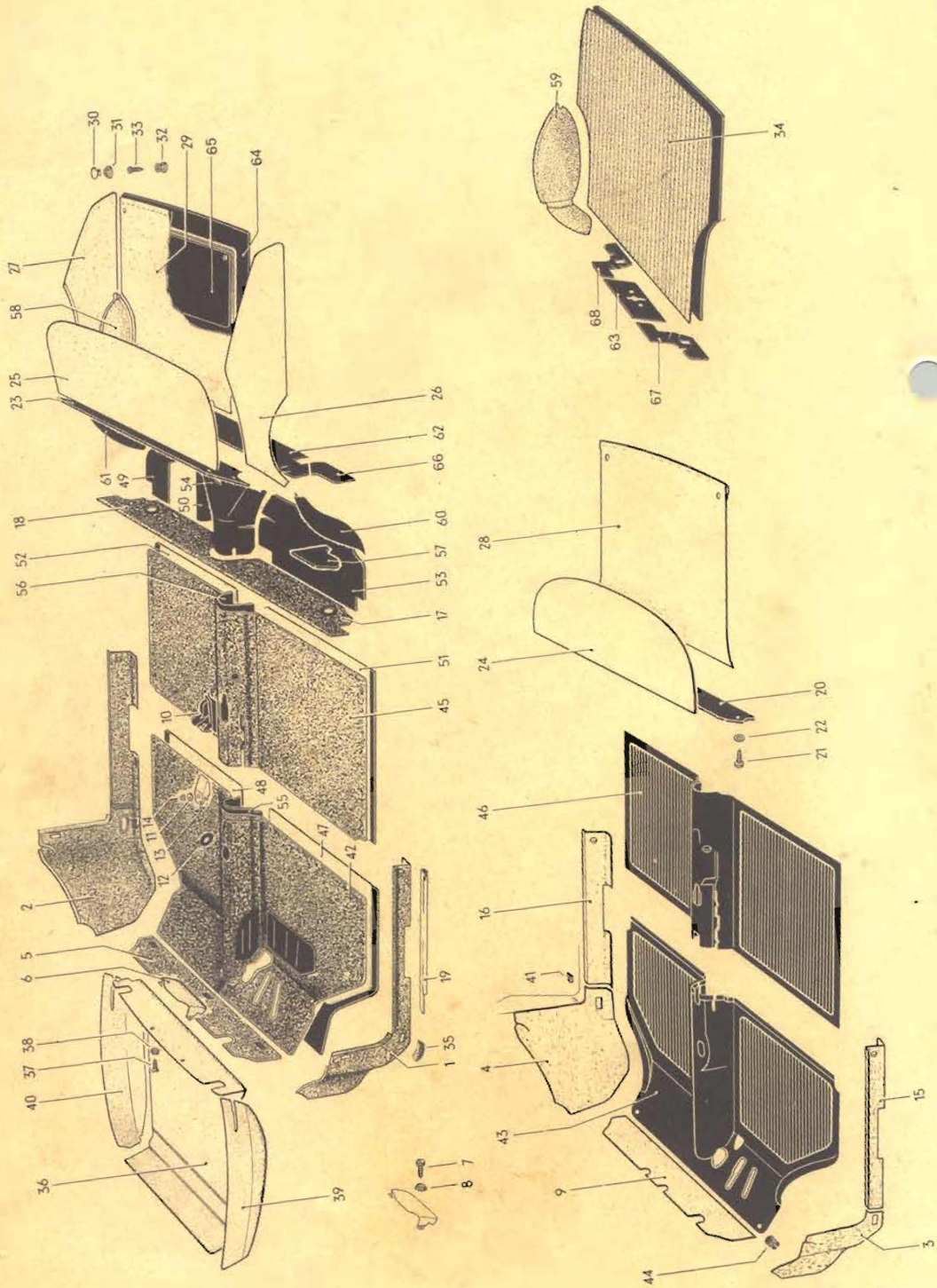

Illustration 49

Type 3



**MAIN GROUP 8**

**BODY**

Key	Part No.	Description	Qty.	Type and model
<b>FRONT PANEL LINING AND FLOOR COVERING</b>				
-	311 863 021 E	Lining, left for front panel and side member to Ch. No. 483 592	1	311-314, 361-364
		from Ch. No. 315 000 001 to 315 220 883	1	311-314, 361-368
	4/61 - 7/65	596 tin grey		
-	311 863 021 G	Lining, left for front panel and side member from Ch. No. 316 000 001 to 317 500 000	1	311-314, 361-368
	8/65 - 7/66	652 scarlet - 79		
	8/65 - 7/67	046 lava - 50, 55, 78, 80, 83, 90, 91, 92		
	8/65 - 7/67	634 ultra blue - 54		
	8/65 - 7/67	662 almond beige - 81, 93		
	8/65 - 7/67	672 rust - 51		
	8/66 - 7/67	772 dark brown - 52		
1	311 863 021 K	Lining, left - Front panel and side member (loop quality) from Ch. No. 318 000 001 to 311 2500 000	1	311-314, 361-364; M 237: 311-314, 365-368
	8/67 - 11/67	066 dark red 68 - 02, 42		
	8/67 - 12/67	072 light beige 68 - 31		
	8/67 - 11/67	192 lava 68 - 01, 08, 43		
	11/67 - 12/67	192 lava 68 - 01, 02, 08, 42, 43		
	8/67 - 7/70	067 medium blue 68 - 04, 14, 21		
	8/67 - 7/70	193 dark brown 68 - 03, 15, 32, 48		
	1/68 - 7/71	192 lava 68 - 01, 02, 08, 13, 17, 18, 19, 20, 27 31, 40, 42, 43, 46, 47, 50, 52		
	8/70 - 7/71	50V blue 71 - 16, 26		
	8/70 - 7/71	80V cork 71 - 22, 28, 53		
-	311 863 021 L	Lining, left - Front panel and side member (loop quality) from Ch. No. 312 2000 001	1	311-314, 361-364; M 237: 311-314, 365-368
	8/71 -	595 lapis blue 72 - 05, 15, 56		
	8/71 -	81S leather beige 72 - 14, 38, 55		
	8/71 -	192 lava 68 - 03, 10, 12, 13, 19, 37, 50, 52, 57		
-	315 863 021 C	Lining, left for front panel and side member from Ch. No. 483 592	1	315-318, 365-368
		from Ch. No. 315 000 001 to 317 500 000	1	315-318
	8/63 - 7/67	046 lava		

-	315 863 021 H	Lining, left for front panel and side member from Ch. No. 317 000 001 to 317 500 000	1	M 234: 315-318
	8/66 - 7/67	046 lava - 50, 90, 91, 92		
	8/66 - 7/67	634 ultra blue - 54		
	8/66 - 7/67	662 almond beige - 93		
	8/66 - 7/67	672 rust - 51		
	8/66 - 7/67	772 dark brown - 52		
-	315 863 021 K	Lining, left for front panel and side member from Ch. No. 318 000 000 to 319 500 000	1	315-318
	8/67 - 7/69	046 lava		
-	315 863 021 L	Lining, left - Front panel and side member (loop quality) from Ch. No. 318 000 001	1	M 234: 315-318; M 237: 315-318
	8/67 - 11/67	066 dark red 68 - 02, 42		
	8/67 - 12/67	072 light beige 68 - 31		
	8/67 - 11/67	192 lava 68 - 01, 08, 43		
	11/67 - 12/67	192 lava 68 - 01, 02, 08, 42, 43		
	8/67 - 7/70	067 medium blue 68 - 04, 14, 21		
	8/67 - 7/70	193 dark brown 68 - 03, 15, 32, 48		
	8/70 - 7/71	50V blue 71 - 16, 26		
	8/70 - 7/71	80V cork 71 - 22, 28, 53		
	1/68 -	192 lava 68 - 01, 02, 03, 08, 10, 12, 13, 17, 18, 19, 20, 27, 31, 37, 40, 42, 43, 46, 47, 50, 52, 57		
	8/71 -	59S lapis blue 72 - 05, 15, 56		
	8/71 -	81S leather beige 72 - 14, 38, 55		
-	365 863 021 C	Lining, left - Front panel and side member from Ch. No. 368 000 001 to 369 500 000	1	365-368; M 233
	8/67 - 7/69	046 lava		
-	311 863 022 E	Lining, right for front panel and side member to Ch. No. 483 592 from Ch. No. 315 000 001 to 315 220 883	1 1	311, 313, 361, 363, 311, 313, 361, 363, 365, 367
	4/61 - 7/65	596 tin grey		
-	311 863 022 G	Lining, right for front panel and side member from Ch. No. 316 000 001 to 317 500 000	1	311, 313, 361, 363, 365, 367
	8/65 - 7/66	652 scarlet - 79		
	8/65 - 7/67	046 lava - 50, 55, 78, 80, 83, 90, 91, 92		
	8/65 - 7/67	634 ultra blue - 54		
	8/65 - 7/67	662 almond beige - 81, 93		
	8/65 - 7/67	672 rust - 51		
	8/66 - 7/67	772 dark brown - 52		

2	311 863 022 K	Lining, right – Front panel and side member (loop quality) from Ch. No. 318 000 001 to 311 2500 000	1	311, 313, 361, 363; M 237: 311, 313, 365, 367
	8/67 – 11/67	066 dark red 68 – 02, 42		
	8/67 – 12/67	072 light beige 68 – 31		
	8/67 – 11/67	192 lava 68 – 01, 08, 43		
	11/67 – 12/67	192 lava 68 – 01, 02, 08, 42, 43		
	8/67 – 7/70	067 medium blue 68 – 04, 14, 21		
	8/67 – 7/70	193 dark brown 68 – 03, 15, 32, 48		
	1/68 – 7/71	192 lava 68 – 01, 02, 08, 13, 17, 18, 19, 20, 27, 31, 40, 42, 43, 46, 47, 50, 52		
	8/70 – 7/71	50V blue 71 – 16, 26		
	8/70 – 7/71	80V cork 71 – 22, 28, 53		
-	311 863 022 L	Lining, right – Front panel and side member (loop quality) from Ch. No. 312 2000 001	1	311, 313, 361, 363; M 237: 311, 313, 365, 367
	8/71 -	59S lapis blue 72 – 05, 15, 56		
	8/71 -	81S leather beige 72 – 14, 38, 55		
	8/71 -	192 lava 68 – 03, 10, 12, 13, 19, 37, 50, 52, 57		
-	312 863 022 E	Lining, right for front panel and side member to Ch. No. 483 592 from Ch. No. 315 000 001 to 315 220 883	1 1	312, 314, 362, 364 312, 314, 362, 364, 366, 368
	4/61 – 7/65	596 tin grey		
-	312 863 022 G	Lining, right for front panel and side member from Ch. No. 316 000 001 to 317 500 000	1	312, 314, 362, 364, 366, 368
	8/65 – 7/66	652 scarlet – 79		
	8/65 – 7/67	046 lava – 50, 55, 78, 80, 83, 90, 91, 92		
	8/65 – 7/67	634 ultra blue – 54		
	8/65 – 7/67	662 almond beige – 81, 93		
	8/65 – 7/67	672 rust – 51		
	8/66 – 7/67	772 dark brown – 52		
-	312 863 022 K	Lining, right – Front panel and side member (loop quality) from Ch. No. 318 000 001 to 311 2500 000	1	312, 314, 362, 364; M 237: 312, 314, 366, 368
	8/67 – 11/67	066 dark red 68 – 02, 42		
	8/67 – 12/67	072 light beige 68 – 31		
	8/67 – 11/67	192 lava 68 – 01, 08, 43		
	11/67 – 12/67	192 lava 68 – 01, 02, 08, 42, 43		
	8/67 – 7/70	067 medium blue 68 – 04, 14, 21		
	8/67 – 7/70	193 dark brown 68 – 03, 15, 32, 48		
	1/68 – 7/71	192 lava 68 – 01, 02, 08, 13, 17, 18, 19, 20, 27, 31, 40, 42, 43, 46, 47, 50, 52		
	8/70 – 7/71	50V blue 71 – 16, 26		
	8/70 – 7/71	80V cork 71 – 22, 28, 53		

-	312 863 022 L	Lining, right - Front panel and side member (loop quality) from Ch. no. 312 2000 001	1	312, 314, 362, 364; M 237: 312, 314, 366, 368
	8/71 -	59S lapis blue 72 - 05, 15, 56		
	8/71 -	81S leather beige 72 - 14, 38, 55		
	8/71 -	192 lava 68 - 03, 10, 12, 13, 19, 37, 50, 52, 57		
-	315 863 022 C	Lining, right for front panel and side member from Ch. No. 221 975 to 483 592	1	315, 317, 365, 367
		from Ch. No. 315 000 001 to 317 500 000	1	315, 317
	8/65 - 7/67	046 lava		
-	315 863 022 H	Lining, right for front panel and side member from Ch. No. 317 000 001 to 317 500 000	1	M 234: 315-318
	8/66 - 7/67	046 lava - 50, 90, 91, 92		
	8/66 - 7/67	634 ultra blue - 54		
	8/66 - 7/67	662 almond beige - 93		
	8/66 - 7/67	672 rust - 51		
	8/66 - 7/67	772 dark brown - 52		
-	315 863 022 K	Lining, right for front panel and side member from Ch. No. 318 000 001 to 319 500 000	1	315, 317
	8/67 - 7/69	046 lava		
-	315 863 022 L	Lining, right - Front panel and side member (loop quality) from Ch. No. 318 000 001	1	M 234: 315, 317; M 237: 315, 317
	8/67 - 11/67	066 dark red 68 - 02, 42		
	8/67 - 12/67	072 light beige 68 - 31		
	8/67 - 11/67	192 lava 68 - 01, 08, 43		
	11/67 - 12/67	192 lava 68 - 01, 02, 08, 42, 43		
	8/67 - 7/70	067 medium blue 68 - 04, 14		
	8/67 - 7/70	193 dark brown 68 - 03, 15, 32, 48		
	8/70 - 7/71	50V blue 71 - 16, 26		
	8/70 - 7/71	80V cork 71 - 22, 28, 53		
	1/68 -	192 lava 68 - 01, 02, 03, 08, 10, 12, 13, 17, 18, 19, 20, 27, 31, 37, 40, 42, 43, 46, 47, 50, 52, 57		
	8/71 -	59S lapis blue 72 - 05, 15, 56		
	8/71 -	81S leather beige 72 - 14, 38, 55		
-	316 863 022 C	Lining, right for front panel and side member from Ch. No. 221 975 to 483 592	1	316, 318, 366, 368
		from Ch. No. 315 000 001 to 317 500 000	1	316, 318
	8/63 - 7/67	046 lava		
-	316 863 022 K	Lining, right - Front panel and side member from Ch. No. 318 000 001 to 319 500 000	1	316, 318
	8/67 - 7/69	046 lava		

-	316 863 022 L	Lining, right - Front panel and side member (loop quality) from Ch. No. 318 000 001	1	M 234: 316,318; M 237: 316,318
	8/67 - 11/67	066 dark red 68 - 02, 42		
	8/67 - 12/67	072 light beige 68 - 31		
	8/67 - 11/67	192 lava 68 - 01, 08, 43		
	11/67 - 12/67	192 lava 68 - 01, 02, 08, 42, 43		
	8/67 - 7/70	067 medium blue 68 - 04, 14		
	8/67 - 7/70	193 dark brown 68 - 03, 15, 32, 48		
	8/70 - 7/71	50V blue 71 - 16, 26		
	8/70 - 7/71	80V cork 71 - 22, 28, 53		
	1/68 -	192 lava 68 - 01, 02, 03, 08, 10, 12, 13, 17, 18, 19, 20, 27, 31, 37, 40, 42, 43, 46, 47, 50, 52, 57		
	8/71 -	59S lapis blue 72 - 05, 15, 56		
	8/71 -	81S leather beige 72 - 14, 38, 55		
-	365 863 022 C	Lining, right - Front panel and side member from Ch. No. 368 000 001 to 369 500 000	1	365,367; M 233: 311,313
	8/67 - 7/69	046 lava		
-	366 863 022 C	Lining, right - Front panel and side member from Ch. No. 368 000 001 to 369 500 000	1	366,368; M 233:312,314
	8/67 - 7/69	046 lava		
3	315 863 023 G	Lining, left - Front panel (felt) from Ch. No. 310 2000 001	1	315-318
	8/69 -	469 anthracite		
-	365 863 023 B	Lining, left - Front panel (felt) from Ch. No. 310 2000 001	1	365-368; M 233
	8/69 -	469 anthracite		
4	315 863 024 G	Lining, right (felt) from Ch. No. 310 2000 001	1	315,317
	8/69 -	469 anthracite		
-	316 863 024 G	Lining, right (felt) from Ch. No. 310 2000 001	1	316,318
	8/69 -	469 anthracite		
-	365 863 024 B	Lining, right (felt) from Ch. No. 310 2000 001	1	365,367; M 233: 311,313
	8/69 -	469 anthracite		
-	366 863 024 B	Lining, right (felt) from Ch. No. 310 2000 001	1	366,368; M 233: 312,314
	8/69 -	469 anthracite		

-	311 863 101 A	Lining - Front panel, center to Ch. No. 317 500 000	1	311, 313, 315, 317, 361, 363, 365, 367; M 234; 315, 317
	4/61 - 7/65	596 tin grey		
	8/65 - 7/66	652 scarlet - 79		
	8/65 - 7/67	046 lava - 50, 55, 78, 80, 83, 90, 91, 92		
	8/65 - 7/67	634 ultra blue - 54		
	8/65 - 7/67	662 almond beige - 81, 93		
	8/65 - 7/67	672 rust - 51		
	8/66 - 7/67	772 dark brown - 52		
5	311 863 101 B	Lining - Front panel, center (loop quality) from Ch. No. 318 000 001	1	311, 313, 361, 363; M 234: 315, 317;
	8/67 - 11/67	066 dark red 68 - 02, 42		365, 367
	8/67 - 12/67	072 light beige 68 - 31		
	8/67 - 11/67	192 lava 68 - 01, 08, 43		
	11/67 - 12/67	192 lava 68 - 01, 02, 08, 42, 43		
	8/67 - 7/70	067 medium blue 68 - 04, 14, 21		
	8/67 - 7/70	193 dark brown 68 - 03, 15, 32, 48		
	8/70 - 7/71	50V blue 71 - 16, 26		
	8/70 - 7/71	80V cork 71 - 22, 28, 53		
	1/68 -	192 lava 68 - 01, 02, 03, 08, 10, 12, 13, 17, 18, 19, 20, 27, 31, 37, 40, 42, 43, 46, 47, 50, 52, 57		
	8/71 -	59S lapis blue 72 - 05, 15, 56		
	8/71 -	81S leather beige 72 - 14, 38, 55		
-	312 863 101 A	Lining - Front panel, center to Ch. No. 317 500 000	1	312, 314, 316, 318, 362, 364, 366, 368; M 234: 316, 318
	4/61 - 7/65	596 tin grey		
	8/65 - 7/66	652 scarlet - 79		
	8/65 - 7/67	046 lava - 50, 55, 78, 80, 83, 90, 91, 92		
	8/65 - 7/67	634 ultra blue - 54		
	8/65 - 7/67	662 almond beige - 81, 83		
	8/65 - 7/67	672 rust - 51		
	8/66 - 7/67	772 dark brown - 52		
-	312 863 101 B	Lining - Front panel, center (loop quality) from Ch. No. 318 000 001	1	312, 314, 362, 364; M 234: 316, 318; M 237: 312, 314, 316, 318, 366, 368
	8/67 - 11/67	066 dark red 68 - 02, 42		
	8/67 - 12/67	072 light beige 68 - 31		
	8/67 - 11/67	192 lava 68 - 01, 08, 43		
	11/67 - 12/67	192 lava 68 - 01, 02, 08, 42, 43		
	8/67 - 7/70	067 medium blue 68 - 04, 14, 21		
	8/67 - 7/70	193 dark brown 68 - 03, 15, 32, 48		
	8/70 - 7/71	50V blue 71 - 16, 26		
	8/70 - 7/71	80V cork 71 - 22, 28, 53		
	1/68 -	192 lava 68 - 01, 02, 03, 08, 10, 12, 13, 17, 18, 19, 20, 27, 31, 37, 40, 42, 43, 46, 47, 50, 52, 57		
	8/71 -	59S lapis blue 72 - 05, 15, 56		
	8/71 -	81S leather beige 72 - 14, 38, 55		

-	315 863 101	Lining - Front panel, center from Ch. No. 221 975 to 483 592	1	315, 317, 365, 367
	8/63 - 7/64	043 grey-black		
-	315 863 101 A	Lining - Front panel, center from Ch. No. 318 000 001 to 319 500 000	1	315, 317, 365, 367; M 233: 311, 313
	8/67 - 7/69	046 lava		
-	316 863 101	Lining - Front panel, center from Ch. No. 221 975 to 483 592	1	316, 318, 366, 368
	8/63 - 7/64	043 grey-black		
-	316 863 101 A	Lining - Front panel, center from Ch. No. 318 000 001 to 319 500 000	1	316, 318, 366, 368; M 233: 312, 314
	8/67 - 7/69	046 lava		
6	311 863 103 B	Lining under instrument panel to Ch. No. 310 2500 000	1	311-314, 361-364; M 234
7	N 14 094 2	Tapping screw, csk. raised hd. B 4. 2x16	2	311-314, 361-364; M 234
8	N 11 701 1	Cone washer A 4. 4	2	311-314, 361-364; M 234
9	315 863 107 B	Lining, center - Front panel (felt) from Ch. No. 310 2000 001	1	315, 317, 365, 367; M 233: 311, 313
	8/69 -	469 anthracite		
-	316 863 107 B	Lining, center - Front panel (felt) from Ch. No. 310 2000 001	1	316, 318, 366, 368; M 233: 311, 313
	8/69 -	469 anthracite		
-	111 863 339 A	Rubber boot for hand brake lever from Ch. No. 317 000 001 to 317 500 000	1	
	8/66 - 7/67	041 black		
-	311 711 461	Rubber boot for hand brake lever (see illustration 36) from Ch. No. 318 000 001	1	
	8/67 -	043 grey-black		
10	311 863 341 A	Rubber boot for hand brake lever to Ch. No. 316 500 000	1	
	4/61 - 7/65	469 anthracite		311-314, 361-364
	8/63 - 12/63	043 grey-black		315-318, 365-368
	1/64 - 7/65	469 anthracite		315-318, 365-368
	8/65 - 7/66	043 grey-black		
11	311 863 347	Washer - Cap nut from Ch. No. 221 975 to 316 500 000	1	
	8/63 - 7/66	046 lava		
12	311 863 351	Cover for heater control to Ch. No. 221 974	1	
	4/61 - 7/63	426 graphite		

13	311 863 353	Cover for heater control from Ch. No. 221 975 to 316 500 000	1	
	8/63 - 12/63	046 lava		315-318, 365-368
	1/64 - 7/65	469 anthracite		315-318, 365-368
	8/63 - 7/65	469 anthracite		311-314, 361-364
	8/65 - 7/66	046 lava		
14	311 863 357 A	Cap nut - Cover from Ch. No. 221 975 to 316 500 000	1	
	8/63 - 12/65	046 lava		315-318, 365-368
	1/64 - 7/65	469 anthracite		315-318, 365-368
	8/63 - 7/65	469 anthracite		311-314, 361-364
	8/65 - 7/66	046 lava		
15	365 863 371 C	Lining, left - Side member (felt) from Ch. No. 310 2000 001	1	315-318, 365-368; M 233
	8/69 -	469 anthracite		
16	365 863 372 C	Lining, right - Side member (felt) from Ch. No. 310 2000 001	1	315-318, 365-368; M 233
	8/69 -	469 anthracite		
-	311 863 381 A	Trim left for kick plate from Ch. No. 316 000 001 to 317 500 000	1	311-314, 361-364, M 234
	8/65 - 7/66	652 scarlet - 79		
	8/65 - 7/67	046 lava - 50, 78, 80, 90, 91, 92		
	8/65 - 7/67	634 ultra blue - 54		
	8/65 - 7/67	662 almond beige - 81, 93		
	8/65 - 7/67	672 rust - 51		
	8/66 - 7/67	772 dark brown - 52		
17	311 863 381 B	Trim left - Kick plate (loop quality) from Ch. No. 318 000 001	1	311-314, 361-364; M 234; M 237: 311-318, 365-368
	8/67 - 11/67	066 dark red 68 - 02, 42		
	8/67 - 12/67	072 light beige 68 - 31		
	8/67 - 11/67	192 lava 68 - 01, 08, 43		
	11/67 - 12/67	192 lava 68 - 01, 02, 08, 42, 43		
	8/67 - 7/70	067 medium blue 68 - 04, 14, 21		
	8/67 - 7/70	193 dark brown 68 - 03, 15, 32, 48		
	8/70 - 7/71	50V blue 71 - 16, 26		
	8/70 - 7/71	80V cork 71 - 22, 28, 53		
	1/68 -	192 lava 68 - 01, 02, 03, 08, 10, 12, 13, 17, 18, 19, 20, 27, 31, 37, 40, 42, 43, 46, 47, 50, 52, 57		
	8/71 -	59S lapis blue 72 - 05, 15, 56		
	8/71 -	81S leather beige 72 - 14, 38, 55		



-	311 863 382	Trim right for kick plate from Ch. No. 316 000 001 to 317 500 000	1	311-314, 361-364; M 234
	8/65 - 7/66	652 scarlet - 79		
	8/65 - 7/67	046 lava - 50, 78, 80, 90, 91, 92		
	8/65 - 7/67	634 ultra blue - 54		
	8/65 - 7/67	662 almond beige - 81, 93		
	8/65 - 7/67	672 rust - 51		
	8/66 - 7/67	772 dark brown - 52		
18	311 863 382 A	Trim right - Kick plate (loop quality) from Ch. No. 318 000 001	1	311-314, 361-364; M 234; M 237: 311-318, 365-368
	8/67 - 11/67	066 dark red 68 - 02, 42		
	8/67 - 12/67	072 light beige 68 - 31		
	8/67 - 11/67	192 lava 68 - 01, 08, 43		
	11/67 - 12/67	192 lava 68 - 01, 02, 08, 42, 43		
	8/67 - 7/70	067 medium blue 68 - 04, 14, 21		
	8/67 - 7/70	193 dark brown 68 - 03, 15, 32, 48		
	8/70 - 7/71	50V blue 71 - 16, 26		
	8/70 - 7/71	80V cork 71 - 22, 28, 53		
	1/68 -	192 lava 68 - 01, 02, 03, 08, 10, 12, 13, 17, 18, 19, 20, 27, 31, 37, 40, 42, 43, 46, 47, 50, 52, 57		
	8/71 -	595 lapis blue 72 - 05, 15, 56		
	8/71 -	815 leather beige 72 - 14, 38, 55		
-	311 863 383 A	Rubber lining, left for kick plate to Ch. No. 483 592	1	
	4/61 - 7/64	426 graphite		311-314, 361-364
	8/63 - 12/63	043 grey-black		315-318, 365-368
	1/64 - 7/64	469 anthracite		315-318, 365-368
-	311 863 383 D	Rubber lining, left for kick plate from Ch. No. 315 000 001 to 315 220 883	1	
	8/64 - 7/65	469 anthracite		
-	315 863 383	Rubber lining, left for kick plate from Ch. No. 221 975 to 320 000	1	315-318, 365-368
	8/63 - 12/63	043 grey-black		
-	311 863 384 A	Rubber lining, right for kick plate to Ch. No. 483 592	1	
	4/61 - 7/64	426 graphite		311-314, 361-364
	1/64 - 7/64	469 anthracite		315-318, 365-368
	8/63 - 12/63	043 grey-black		315-318, 365-368
-	311 863 384 C	Rubber lining, right for kick plate from Ch. No. 315 000 001 to 315 220 883	1	
	8/64 - 7/65	469 anthracite		

-	315 863 384	Rubber lining, right for kick plate from Ch. No. 221 975 to 483 592	1	315-318, 365-368
	8/63 - 12/63	043 grey-black		
19	311 863 399 A	Cover plate - Main harness	1	311-314, 361-368
20	311 863 411 A	Protection panel, front Luggage compartment, rear to Ch. No. 315 220 883	1	311-318
		from Ch. No. 316 000 001	1	315-318
21	N 11 377 1	Tapping screw, cheese hd. B 3.9x25 to Ch. No. 315 220 883	1	311-318
		from Ch. No. 316 000 001	1	315-318
22	N 11 555 1	Washer 4.3 to Ch. No. 315 220 883	1	311-318
		from Ch. No. 316 000 001	1	315-318
23	311 863 411 B	Protection panel, front to Ch. No. 316 000 001	1	311-314
24	311 863 413	Lining - Parcel shelf, rear to Ch. No. 315 220 883	1	311-318
		from Ch. No. 316 000 001	1	315-318
	4/61 - 7/64	466 silver beige		
	8/64 -	581 cloud white		
25	311 863 413 A	Lining - Parcel shelf, rear from Ch. No. 316 000 001 to 310 2500 000	1	311-314; M 237: 311-314
	8/65 - 7/66	652 scarlet - 79		
	8/65 - 7/67	634 ultra blue - 54		
	8/65 - 7/67	672 rust - 51		
	8/65 - 7/68	662 almond beige - 31, 81, 93		
	8/65 - 7/70	192 lava 68 - 01, 08, 13, 19, 20, 21, 40, 43, 46, 47, 48, 50, 78, 80, 90, 92		
	8/66 - 7/67	149 dark khaki brown - 52		
	8/66 - 7/67	752 Indian red - 91		
	8/67 - 7/68	173 Indian red 68 - 02, 42		
	8/67 - 7/68	191 khaki brown 68 dark - 03, 32		
	8/67 - 7/70	045 Capri blue 68 - 04, 14		
	8/68 - 7/70	718 nut brown 69 - 15, 48		
	8/68 - 7/70	719 gala red 69 - 47		
	8/68 - 7/70	720 cream white 69 - 46		
-	311 863 413 B	Lining - Parcel shelf, rear (felt) from Ch. No. 311 2000 001 to 311 2500 000	1	311-314; M 237:311-314
	8/70 - 7/71	046 lava - 17, 27, 40, 52		
	8/70 - 7/71	50V blue 71 - 26		
	8/70 - 7/71	80V cork 71 - 28, 53		
	8/70 - 7/71	719 gala red 69 - 01, 47		

-	311 863 413 C	Lining - Parcel shelf, rear (felt) from Ch. No. 312 2000 001	1	311-314; M237:311-314
	8/71 -	046 lava - 03, 05, 10, 12, 13, 37, 38, 50, 52		
	8/71 -	35S bordeaux red 72 - 19, 57		
	8/71 -	59S lapis blue 72 - 15, 56		
	8/71 -	81S leather beige 72 - 14, 55		
-	311 863 455	Lining, left - Luggage compartment, rear from Ch. No. 318 000 001 to 310 2500 000	1	M 236: 311-314
-	311 863 455 A	Lining, left - Luggage compartment, rear from Ch. No. 311 2000 001	1	M 236: 311-314
-	311 863 461 A	Lining, left - Luggage compartment, rear to Ch. No. 315 220 883	1	311-314
		from Ch. No. 317 000 001 to 317 500 000	1	M 234: 315-318
26	311 863 461 B	Lining, left - Luggage compartment, rear from Ch. No. 316 000 001 to 310 2500 000	1	311-314
-	311 863 461 D	Lining, left - Luggage compartment, rear from Ch. No. 311 2000 001	1	311-314
-	315 863 461	Lining, left - Luggage compartment, rear from Ch. No. 318 000 001	1	M 234: 315-318
-	311 863 462 A	Lining right - Luggage compartment, rear to Ch. No. 315 220 883	1	311-314
		from Ch. No. 317 000 001	1	M 234: 315-318
27	311 863 462 B	Lining right - Luggage compartment, rear from Ch. No. 316 000 001 to 310 2500 000	1	311-314
-	311 863 462 D	Lining, right - Luggage compartment, rear from Ch. No. 311 2000 001	1	311-314
28	311 863 463	Lining - Luggage compartment floor, rear to Ch. No. 315 220 883	1	311-318
		from Ch. No. 316 000 001	1	315-318
29	311 863 463 A	Lining - Luggage compartment floor, rear from Ch. No. 316 000 001	1	311-314
30	141 871 439 B	Button for lining	2	311-318
31	141 871 440 B	*Stud for lining	2	311-318
32	311 863 581	*Press stud-lower part for lining	2	311-318
33	N 13 958 3	Tapping screw, cheese hd. B 3.5x13	2	311-318
34	361 863 465	Rubber lining for luggage compartment floor, rear to Ch. No. 315 220 883	1	361-368
		from Ch. No. 316 000 001	1	361-364
	4/61 - 7/63	426 graphite		361-368
	4/61 - 7/65	469 anthracite		361-364
	8/65 - 7/66	652 scarlet - 79		361-364
	8/65 - 7/67	046 lava - 50, 78, 80, 90, 91, 92		361-364
	8/65 - 7/67	662 almond beige - 81, 93		361-364

	8/65 - 7/67	672 rust - 51		361-364
	8/66 - 7/67	772 dark brown - 52		361-364
	8/67 - 12/67	046 lava - 01, 02, 08, 42, 43		361-364
	8/65 - 7/70	634 ultra blue - 04, 14, 54		361-364
	8/67 - 12/67	072 light beige 68 - 31		361-364
	8/67 - 7/70	772 dark brown - 03, 15, 32, 48		361-364
	1/68 - 7/70	046 lava - 01, 02, 08, 13, 31, 40, 42, 43, 46, 48		361-364
	8/70 - 7/71	50V blue 71 - 26		361-364
	8/70 - 7/71	80V cork 71 - 28, 53		361-364
	8/70 -	727 grey 69 - 01, 12, 13, 19, 27, 40, 47, 50, 52, 57		361-364
	8/71 -	59S lapis blue 72 - 15, 56		361-364
	8/71 -	81S leather beige 72 - 14, 55		361-364
-	365 863 465	Rubber lining for luggage compartment floor, rear from Ch. No. 316 000 001	1	365-368
	8/65 -	041 black		
35	311 863 497	Packing - Side member from Ch. No. 316 000 001	1	311-314, 361-368
-	311 863 505 A	Fiber board - Front luggage compartment to Ch. No. 317 500 000	1	
-	311 863 505 G	Fiber board - Front luggage compartment from Ch. No. 318 000 001 to 319 500 000	1	
36	311 863 505 E	Fiber board - Front luggage compartment from Ch. No. 310 2000 001 to 310 2500 000	1	
-	311 863 505 J	Fiber board - Front luggage compartment from Ch. No. 311 2000 001	1	
37	N 11 460 1	Tapping screw, csk. hd. B 3.5x13 to Ch. No. 319 500 000	4	
		from Ch. No. 310 2000 001 to 310 2500 000	2	
38	N 11 578 1	Concave washer 3.7 to Ch. No. 319 500 000	4	
		from Ch. No. 310 2000 001 to 310 2500 000	2	
-	311 863 509	Lining, left for front luggage compartment to Ch. No. 317 500 000	1	311-314, 361-364; M 234
39	311 863 509 E	Lining, left for front luggage compartment from Ch. No. 318 000 001 to 310 2500 000	1	311-314, 361-364; M 233; M 234
-	311 863 509 H	Lining, left for luggage compartment from Ch. No. 311 2000 001	1	311-314, 361-364; M 233; M 234
-	311 863 510	Lining, right for front luggage compartment to Ch. No. 317 500 000	1	311-314, 361-364; M 234
40	311 863 510 A	Lining, right for front luggage compartment to Ch. No. 318 000 001 to 310 2500 000	1	311-314, 361-364; M 233; M 234

-	311 863 510 H	Lining, right for front luggage compartment from Ch. No. 311 2000 001	1	311-314, 361-364; M 233; M 234
-	311 863 543	Lining, rear for front luggage compartment from Ch. No. 311 2000 001	1	311-314, 361-364
41	315 863 671	Plug for door contact lever hole from Ch. No. 221 975 to 317 500 000	2	315-318, 365-368
-	311 863 703 B	Mat - Floor, front to Ch. No. 221 974	1	311, 313, 361, 363
-	311 863 703 D	Mat - Floor, front from Ch. No. 315 000 001 to 315 220 883 469 anthracite	1	311, 313, 315, 317, 361, 363, 365, 367
-	8/64 - 7/65			
-	311 863 703 F	Mat - Floor, front from Ch. No. 316 000 001 to 317 500 000	1	311, 313, 361, 363; M 234: 315, 317
	8/65 - 7/66	652 scarlet - 79		
	8/65 - 7/67	046 lava - 50, 78, 80, 90, 91, 92		
	8/65 - 7/67	634 ultra blue - 54		
	8/65 - 7/67	662 almond beige - 81, 93		
	8/65 - 7/67	672 rust - 51		
	8/66 - 7/67	772 dark brown - 52		
-	311 863 703 G	Mat - Floor, front (loop quality) from Ch. No. 318 015 226	1	M 249: 311, 313, 361, 363; M 249/M 234: 315, 317; M 249/M 237: 311, 313, 315, 317, 365, 367
	8/67 - 11/67	066 dark red 68 - 02, 42		
	8/67 - 12/67	072 light beige 68 - 31		
	8/67 - 11/67	192 lava 68 - 01, 08, 43		
	11/67 - 12/67	192 lava 68 - 01, 02, 08, 42, 43		
	8/67 - 7/70	067 medium blue 68 - 04, 14, 21		
	8/67 - 7/70	193 dark brown 68 - 03, 15, 32, 48		
	8/70 - 7/71	50V blue 71 - 16, 26		
	8/70 - 7/71	80V cork 71 - 22, 28, 53		
	1/68 -	192 lava 68 - 01, 02, 03, 08, 10, 12, 13, 17, 18, 19, 20, 27, 31, 37, 40, 42, 43, 46, 47, 50, 52, 57		
	8/71 -	59S lapis blue 72 - 05, 15, 56		
	8/71 -	81S leather beige 72 - 14, 38, 55		
42	311 863 703 H	Mat - Floor, front (loop quality) from Ch. No. 318 000 001	1	311, 313, 361, 363; M 234: 315, 317; M 237: 311, 313, 315, 317 365, 367
	8/67 - 11/67	066 dark red 68 - 02, 42		
	8/67 - 12/67	072 light beige 68 - 31		
	8/67 - 11/67	192 lava 68 - 01, 08, 43		
	11/67 - 12/67	192 lava 68 - 01, 02, 08, 42, 43		
	8/67 - 7/70	067 medium blue 68 - 04, 14, 21		

8/67 - 7/70	193 dark brown 68 - 03, 15, 32, 48		
8/70 - 7/71	50V blue 71 - 16, 26		
8/70 - 7/71	80V cork 71 - 22, 28, 53		
1/68 -	192 lava 68 - 01, 02, 03, 08, 10, 12, 13, 17, 18, 19, 20, 27, 31, 37, 40, 42, 43, 46, 47, 50, 52, 57		
8/71 -	59S lapis blue 72 - 05, 15, 56		
8/71 -	81S leather beige 72 - 14, 38, 55		
- 312 863 703 B	Mat - Floor, front to Ch. No. 221 974	1	312, 314, 362, 364
- 312 863 703 D	Mat - Floor, front from Ch. No. 315 000 001 to 315 220 883	1	312, 314, 316, 318, 362, 364, 366, 368
8/64 - 7/65	469 anthracite		
- 312 863 703 F	Mat - Floor, front from Ch. No. 316 000 001 to 317 500 000	1	312, 314, 362, 364; M 234: 316, 318
8/65 - 7/66	652 scarlet - 79		
8/65 - 7/67	046 lava - 50, 78, 80, 90, 91, 92		
8/65 - 7/67	634 ultra blue - 54		
8/65 - 7/67	662 almond beige - 81, 93		
8/65 - 7/67	672 rust - 51		
8/66 - 7/67	772 dark brown - 52		
- 312 863 703 G	Mat - Floor, front (loop quality) from Ch. No. 318 015 226	1	M 249: 312, 314, 362, 364; M 249/M 234: 316, 318; M 249/M 237: 312, 314, 318, 366, 368
8/67 - 11/67	066 dark red 68 - 02, 42		
8/67 - 12/67	072 light beige 68 - 31		
8/67 - 11/67	192 lava 68 - 01, 08, 43		
11/67 - 12/67	192 lava 68 - 01, 02, 08, 42, 43		
8/67 - 7/70	067 medium blue 68 - 04, 14, 21		
8/67 - 7/70	193 dark brown 68 - 03, 15, 32, 48		
8/70 - 7/71	50V blue 71 - 16, 26		
8/70 - 7/71	80V cork 71 - 22, 28, 53		
1/68 -	192 lava 68 - 01, 02, 03, 08, 10, 12, 13, 17, 18, 19, 20, 27, 31, 37, 40, 42, 43, 46, 47, 50, 52, 57		
8/71 -	59S lapis blue 72 - 05, 15, 56		
8/71 -	81S leather beige 72 - 14, 38, 55		
- 312 863 703 H	Mat - Floor, front (loop quality) from Ch. No. 318 000 001 to 319 111 029	1	312, 314, 362, 364; M 234: 316, 318
8/67 - 11/67	066 dark red 68 - 02, 42		
8/67 - 12/67	072 light beige 68 - 31		
8/67 - 11/67	192 lava 68 - 01, 08, 43		
11/67 - 12/67	192 lava 68 - 01, 02, 08, 42, 43		
8/67 - 12/68	067 medium blue 68 - 04, 14		
8/67 - 12/68	193 dark brown 68 - 03, 15, 32, 48		
1/68 - 12/68	192 lava 68 - 01, 02, 08, 13, 31, 40, 42, 43, 46, 47		

-	312 863 703 J	Mat - Floor, front (loop quality) from Ch. No. 319 111 030	1	312, 314, 362, 364; M 234: 316, 318; M 237: 312, 314, 315, 316, 366, 368
	1/69 - 7/70	067 medium blue 68 - 14, 21		
	1/69 - 7/70	193 dark brown 68 - 15, 19, 20, 48, 50		
	8/70 - 7/71	50V blue 71 - 16, 26		
	8/70 - 7/71	80V cork 71 - 22, 28, 53		
	1/69 -	192 lava 68 - 03, 10, 12, 13, 17, 18, 19, 27, 37, 40, 46, 47, 50, 52, 57		
	8/71 -	59S lapis blue 72 - 05, 15, 56		
	8/71 -	81S leather beige 72 - 14, 38, 55		
-	315 863 703	Mat - Floor, front from Ch. No. 221 975 to 483 592	1	
	8/63 - 7/64	426 graphite		311, 313, 361, 363
	8/63 - 12/63	043 grey-black		315, 317, 365, 367
	1/64 - 7/64	469 anthracite		315, 317, 365, 367
-	316 863 703	Mat - Floor, front from Ch. No. 221 975 to 483 592	1	
	8/63 - 7/64	426 graphite		312, 314, 362, 364
	8/63 - 12/63	043 grey-black		316, 318, 366, 368
	1/64 - 7/64	469 anthracite		316, 318, 366, 368
43	365 863 703 B	Mat - Floor, front from Ch. No. 316 000 001	1	315, 317, 365, 367; M 233: 311, 313
	8/65 -	041 black		
-	365 863 703 C	Mat - Floor, front from Ch. No. 318 015 226	1	M 249: 315, 317, 365, 367; M 249/M 233: 311, 313
	8/67 -	041 black		
-	366 863 703 F	Mat - Floor, front from Ch. No. 316 000 001	1	316, 318, 366, 368; M 233: 312, 314; M 249: 316, 318, 366, 368; M 249/M 233: 312, 314
	8/65 -	041 black		
44	315 863 715	Retaining button for floor mat, front from Ch. No. 319 111 030	2	315-318, 365-368; M 233; M 249: 315-318, 365-368; M 249/M 233
-	311 863 717 A	Mat - Floor, rear to Ch. No. 47 000	1	
	4/61 - 6/62	426 graphite		
-	311 863 717 F	Mat - Floor, rear from Ch. No. 315 000 001 to 315 220 883	1	
	8/64 - 7/65	469 anthracite		
-	311 863 717 J	Mat - Floor, rear from Ch. No. 316 000 001 to 316 500 000	1	311-314, 361-364
	8/65 - 7/66	634 ultra blue - 54		
	8/65 - 7/66	652 scarlet - 79		
	8/65 - 7/66	662 almond beige - 81		
	8/65 - 7/66	672 rust - 51		

-	311 863 717 K	Mat - Floor, rear from Ch. No. 316 000 001 to 317 500 000	1	311-314, 361-364; M 234
	8/65 - 7/67	046 lava - 50, 78, 80, 90, 91, 92		
	8/66 - 7/67	634 ultra blue - 54		
	8/66 - 7/67	662 almond beige - 93		
	8/66 - 7/67	772 dark brown - 52		
	8/66 - 7/67	672 rust - 51		
45	311 863 717 N	Mat - Floor, rear (loop quality) from Ch. No. 318 000 001	1	311-314, 361-364; M 249; M 234; M 237: 311-318, 365-368
	8/67 - 11/67	066 dark red 68 - 02, 42		
	8/67 - 12/67	072 light beige 68 - 31		
	8/67 - 11/67	192 lava 68 - 01, 08, 43		
	11/67 - 12/67	192 lava 68 - 01, 02, 08, 42, 43		
	8/67 - 7/70	067 medium blue 68 - 04, 14, 21		
	8/67 - 7/70	193 dark brown 68 - 03, 15, 32, 48		
	8/70 - 7/71	50V blue 71 - 16, 26		
	8/70 - 7/71	80V cork 71 - 22, 28, 53		
	1/68 -	192 lava 68 - 01, 02, 03, 08, 10, 12, 13, 17, 18, 19, 20, 27, 31, 37, 40, 42, 43, 46, 47, 50, 52, 57		
	8/71 -	59S lapis blue 72 - 05, 15, 56		
	8/71 -	81S leather beige 72 - 14, 38, 55		
-	315 863 717	Mat - Floor, rear from Ch. No. 221 975 to 483 592	1	
	8/63 - 7/64	426 graphite		311-314, 361-364
	8/63 - 12/63	043 grey-black		315-318, 365-368
	1/64 - 7/64	469 anthracite		315-318, 365-368
46	365 863 717 D	Mat - Floor, rear from Ch. No. 316 000 001	1	315-318, 365-368; M 233
	8/65 -	041 black		
47	311 863 851 B	Sound absorber, front for floor plate, left	1	
48	311 863 852 B	Sound absorber, front for floor plate, right	1	
49	311 863 853	Sound absorber rear, outer for floor plate, right	1	
50	311 863 854	Sound absorber rear, inner for floor plate, right	1	
51	311 863 855 A	Sound absorber, center for floor plate, left	1	
52	311 863 856 A	Sound absorber, center for floor plate, right	1	
53	311 863 857	Sound absorber, rear for floor plate, left	1	
54	311 863 861 C	Sound absorber for frame tunnel, rear	1	
55	311 863 871 D	Sound absorber, front for frame tunnel	1	



56	311 863 873 F	Sound absorber for frame tunnel, center	1	
57	311 863 877	Insulation for sealing plate over rear wheel housing to Ch. No. 315 220 883	2	311-318
		from Ch. No. 316 000 001	2	315-318
-	311 863 879	Lining for wheel housing, rear left from Ch. No. 316 000 001	1	311-314
-	361 863 879	Lining for wheel housing, rear left to Ch. No. 365 220 883	1	361-368
		from Ch. No. 366 000 001	1	361-364
	4/61 - 7/63	426 graphite		361-364
	4/61 - 7/65	469 anthracite		361-368
	8/65 - 7/66	652 scarlet - 79		361-364
	8/65 - 7/67	662 almond beige - 81, 93		361-364
	8/65 - 7/67	672 rust - 51		361-364
	8/65 - 12/67	046 lava - 01,02,08,42,43,50,78,80,90,91,92		361-364
	8/67 - 12/67	072 light beige 68 - 31		361-364
	8/65 - 7/70	634 ultra blue - 04, 14, 54		361-364
	8/66 - 7/70	772 dark brown - 03, 15, 32, 48, 52		361-364
	1/68 - 7/70	046 lava - 01,02,08,13,31,40,42,43,46,47		361-364
	8/70 - 7/71	50V blue 71 - 26		361-364
	8/70 - 7/71	81V cork 71 - 28, 53		361-364
	8/70 -	727 grey 69 - 01, 12, 13, 19, 22, 27, 40, 47, 50, 52, 57		
	8/71 -	59S lapis blue 72 - 15, 56		361-364
	8/71 -	81S leather beige 72 - 14, 55		361-364
-	365 863 879	Lining for wheel housing, rear left from Ch. No. 366 000 001	1	365-368
	8/65 -	041 black		
58	311 863 880	Lining for wheel housing, rear right from Ch. No. 316 000 001	1	311-314
59	361 863 880	Lining for wheel housing, rear right to Ch. No. 365 220 883	1	361-368
		from Ch. No. 366 000 001	1	361-364
	4/61 - 7/63	426 graphite		361-364
	4/61 - 7/65	469 anthracite		361-368
	8/65 - 7/66	652 scarlet - 79		361-364
	8/65 - 7/67	662 almond beige - 81, 93		361-364
	8/65 - 7/67	672 rust - 51		361-364
	8/65 - 12/67	046 lava - 01,02,08,42,43,50,78,80,90,91,92		361-364

	8/67 - 12/67	072 light beige 68 - 31		361-364
	8/65 - 7/70	634 ultra blue - 04, 14, 54		361-364
	8/66 - 7/70	772 dark brown - 03, 15, 32, 48, 52		361-364
	1/68 - 7/70	046 lava - 01, 02, 08, 13, 31, 40, 42, 43, 46, 47		
	8/70 - 7/71	50V blue 71 - 26		361-364
	8/70 - 7/71	80V cork 71 - 28, 53		361-364
	8/70 -	727 grey 69 - 01, 12, 13, 19, 22, 27, 40, 47, 50, 52, 57		
	8/71 -	59S lapis blue 72 - 15, 56		361-364
	8/71 -	81S leather beige 72 - 14, 55		361-364
-	365 863 880	Lining for wheel housing, rear right from Ch. No. 366 000 001	1	365-368
	8/65 -	041 black		
60	311 863 881 C	Sound absorber for wheel housing, rear left	1	311-318
61	311 863 882 B	Sound absorber for wheel housing, rear right	1	311-318
-	311 863 891 B	Sound absorber, front, lower, center for rear luggage compartment floor to Ch. No. 317 500 000	1	311-318
62	311 863 891 D	Sound absorber, front, lower, center for rear luggage compartment floor from Ch. No. 318 000 001	1	311-318
-	361 863 891 A	Sound absorber, front, lower, center for rear luggage compartment floor to Ch. No. 367 500 000	1	361-368
63	361 863 891 B	Sound absorber, front, lower, center for rear luggage compartment floor from Ch. No. 368 000 001	1	361-368
-	311 863 893	Sound absorber for rear luggage compartment floor to Ch. No. 315 220 883 from Ch. No. 316 000 001	1 1	311-318 315-318
64	361 863 893	Sound absorber for rear luggage compartment floor to Ch. No. 315 220 883 from Ch. No. 316 000 001	1 1	361-368 311-314, 361-368
65	361 863 895	Sound absorber for engine compartment lid	1	
66	311 863 901	Sound absorber, front lower, side for rear luggage compartment floor from Ch. No. 280 371	2	311-318
67	361 863 901 A	Sound absorber, upper part front lower for rear luggage compartment	2	361-368
68	361 863 903	Sound absorber, lower part front lower for rear luggage compartment floor	2	361-368



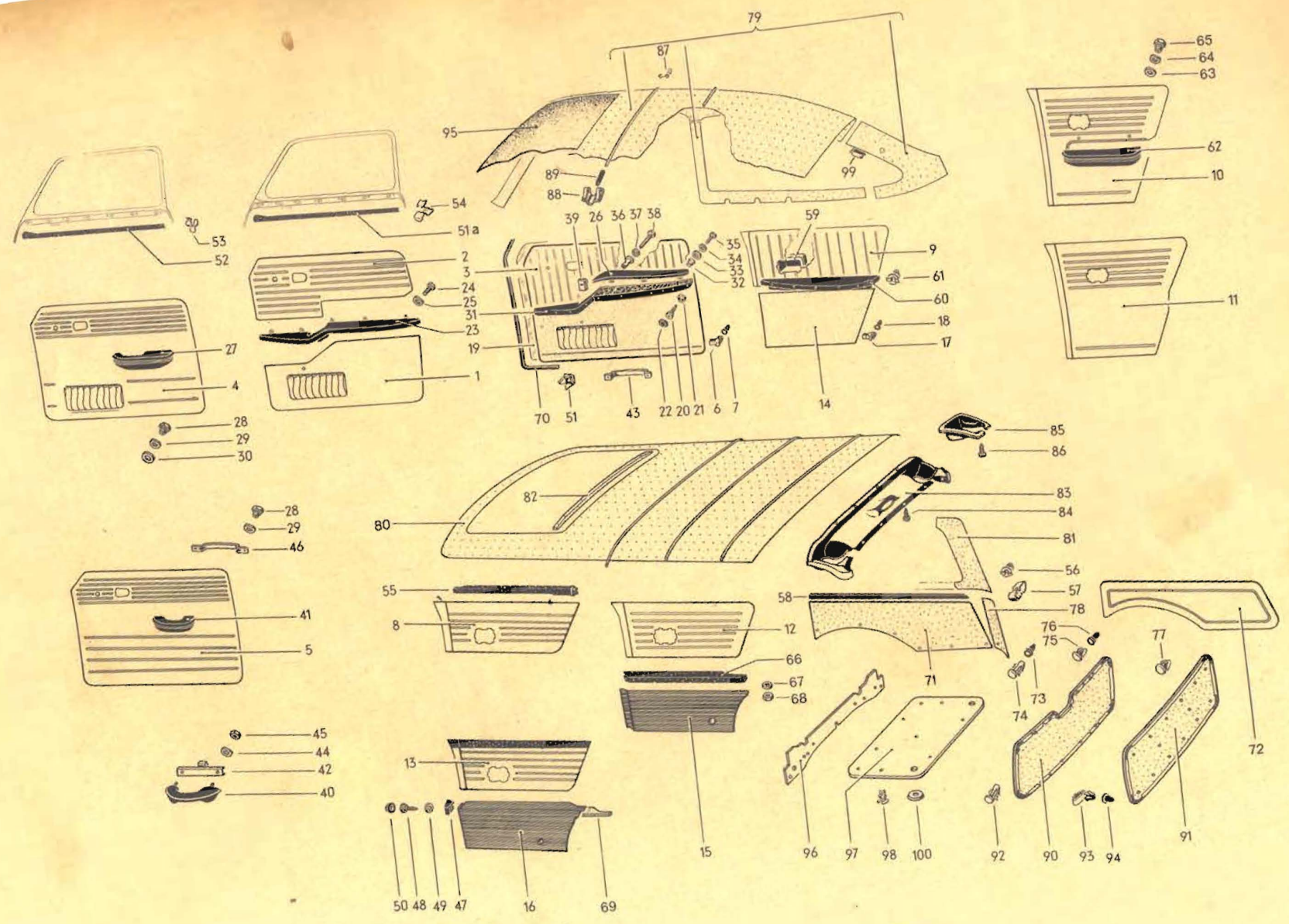

**MAIN GROUP 8**

**BODY**

Key	Part No.	Description	Qty.	Type and model
<b>INTERIOR TRIM</b>				
-	311 867 012	Trim panel - Door, upper, right to Ch. No. 221 974	1	
	4/61 - 7/63	466 silver beige		
-	311 867 913 A	Trim panel - Door, lower, left (cloth/leatherette) to Ch. No. 221 974	1	
	4/61 - 7/63	251 black-white/anthracite		
-	311 867 013 B	Trim panel - Door, lower, left from Ch. No. 221 975 to 315 220 883	1	311-314, 361-364
	8/63 - 7/64	049 brown - 51, 71		
	8/63 - 7/64	002 green - 52, 72		
	8/63 - 7/65	797 oxide red - 73, 87		
	8/64 - 7/65	753 dolomite grey - 53, 83		
	8/64 - 7/65	754 Burma green - 52, 86		
-	311 867 014 A	Trim panel - Door, lower, right (cloth/leatherette) to Ch. No. 221 974	1	
	4/61 - 7/63	251 black-white/anthracite		
1	311 867 014 B	Trim panel - Door, lower, right from Ch. No. 221 975 to 315 220 883	1	311-314, 361-364
	8/63 - 7/64	049 brown - 51, 71		
	8/63 - 7/64	002 green - 52, 72		
	8/63 - 7/65	797 oxide red - 73, 87		
	8/64 - 7/65	754 Burma green - 52, 86		
-	311 867 015	Trim panel - Door, upper, left from Ch. No. 221 975 to 315 220 883	1	311-314, 361-364
	8/63 - 7/64	573 light grey - 50, 70, 73		
	8/64 / 7/65	597 Oxford grey - 53, 83, 87		
	8/64 - 7/65	384 pampas green - 52, 86		
-	311 867 015 A	Trim panel - Door, left from Ch. No. 316 000 001 to 316 500 000	1	311-314, 361-364
	8/65 - 7/66	697 platinum - 50, 78		
	8/65 - 7/66	671 teak - 51		
	8/65 - 7/66	637 azure - 54		
	8/65 - 7/66	651 pigalle - 79		
	8/65 - 7/66	667 Balearic beige - 81		
	8/65 - 7/66	941 black - 80		
-	311 867 015 B	Trim panel - Door, left from Ch. No. 317 000 001 to 317 500 000	1	311-314, 361-364; M 234
	8/66 - 7/67	920 khaki brown/black - 52		
	8/66 - 7/67	921 azure/black - 54		

-	311 867 015 D	Trim panel - Door, left from Ch. No. 317 000 001 to 310 2500 000	1	311-314, 361-364; M 234
	8/66 - 7/67	041 black/black - 92		
	8/66 - 7/67	922 teak/black - 51		
	8/66 - 7/67	923 Indian red /black - 91		
	8/66 - 7/68	185 platinum/lava - 01, 50, 90		
	8/67 - 7/68	186 khaki brown 68/oxide brown - 03, 32		
	8/67 - 7/68	AE9 light sand 68/lava - 31		
	8/67 - 7/68	AF0 Indian red 68/lava - 02, 42		
	8/67 - 7/70	197 Capri blue 68/Capri blue 68 - 04, 14		
	8/67 - 7/70	198 black 68/black - 08, 40, 43		
	8/68 - 7/70	733 gala red 69/lava - 01, 47		
-	311 867 015 F	Trim panel - Door, left from Ch. No. 319 000 001	1	311-314, 361-364; M 234
	8/68 - 7/70	718 nut brown 69/nut brown 69 - 15, 48		
	8/68 - 7/70	731 quick grey 69/lava - 13		
	8/68 - 7/70	732 cream white 69/lava - 46		
	8/70 - 7/71	50V blue 71 - 26		
	8/70 - 7/71	80V cork 71 - 28, 53		
	8/70 - 7/71	719 gala red 69 - 01, 47		
	8/70 -	71V alabaster 71 - 13, 27, 52		
	8/70 -	172 black 68 - 12, 40, 50		
	8/71 -	35S bordeaux red 72 - 19, 57		
	8/71 -	59S lapis blue 72 - 15, 56		
	8/71 -	81S leather beige 72 - 14, 55		
-	315 867 015	Trim panel - Door, left from Ch. No. 221 975 to 315 220 883	1	315-318, 365-368
	8/63 - 7/64	862 hemp beige/brown - 71		
	8/63 - 7/64	867 sea gull grey/green - 72		
	8/64 - 7/65	868 Oxford grey/dolomite grey - 53, 83		
	8/64 - 7/65	869 pampas green/Burma green - 52, 86		
-	315 867 015 E	Trim panel - Door, left from Ch. No. 316 000 001	1	315-318, 365-368; M 233; M 237: 311-318, 365-368
	8/65 - 7/70	721 platinum 69 - 05, 19, 22, 38, 50, 55, 74, 86		
	8/69 - 7/70	045 capri blue 68 - 21		
	8/69 - 7/70	718 nut brown 69 - 48		
	8/69 - 7/71	719 gala red 69 - 18, 20, 47		
	8/70 - 7/71	50V blue 71 - 16		
	8/70 - 7/71	80V cork 71 - 22, 53		
	3/66 -	172 black 68 - 08, 37, 40, 50, 76, 88		
	8/70 -	71V alabaster 71 - 03, 17, 52		
	8/71 -	35S bordeaux red 72 - 10, 57		
	8/71 -	59S lapis blue 72 - 05, 56		
	8/71 -	81S leather beige 72 - 38, 55		

2	311 867 016	Trim panel – Door, upper, right from Ch. No. 221 975 to 315 220 883	1	311-314, 361-364
	8/63 – 7/64	573 light grey – 50, 70, 73		
	8/63 – 7/64	791 hemp beige – 51, 52, 71, 72		
	8/64 – 7/65	384 pampas green – 52, 86		
	8/64 – 7/65	597 Oxford grey – 53, 83, 87		
3	311 867 016 A	Trim panel – Door, right from Ch. No. 316 000 001 to 316 500 000	1	311-314, 361-364
	8/65 – 7/66	041 black – 80		
	8/65 – 7/66	637 azure – 54		
	8/65 – 7/66	651 pigalle – 79		
	8/65 – 7/66	667 Balearic beige – 81		
	8/65 – 7/66	671 teak – 51		
	8/65 – 7/66	697 platinum – 50, 78		
–	311 867 016 B	Trim panel – Door, right from Ch. No. 317 000 001 to 317 500 000	1	311-314, 361-364; M 234
	8/66 – 7/67	920 khaki brown/black – 52		
	8/66 – 7/67	921 azure/black – 54		
	8/66 – 7/67	922 teak/black – 51		
	8/66 – 7/67	924 Balearic beige/black – 93		
–	311 867 016 D	Trim panel – Door, right from Ch. No. 317 000 001 to 310 2500 000	1	311-314, 361-364; M 234
	8/66 – 7/67	041 black/black – 92		
	8/66 – 7/68	185 platinum/lava – 01, 50, 90		
	8/66 – 7/67	923 Indian red/black – 91		
	8/67 – 7/68	186 khaki brown 68/oxide brown – 03, 32		
	8/67 – 7/68	AE9 light sand 68/lava – 31		
	8/67 – 7/68	AFC Indian red 68/lava – 02, 42		
	8/67 – 7/70	197 Capri blue 68/Capri blue 68 – 04, 14		
	8/67 – 7/70	198 black 68/black – 08, 40, 43		
	8/68 – 7/70	733 gala red 69/lava – 01, 47		
4	311 867 016 F	Trim panel – Door, right from Ch. No. 319 000 001	1	311-314, 362-364; M 234
	8/68 – 7/70	718 nut brown 69/nut brown 69 – 15, 48		
	8/68 – 7/70	731 quick grey 69/lava – 13		
	8/68 – 7/70	732 cream white 69/lava – 46		
	8/70 – 7/71	50V blue 71 – 26		
	8/70 – 7/71	80V cork 71 – 28, 53		
	8/70 – 7/71	719 gala red 69 – 01, 47		
	8/70 –	71V alabaster 71 – 13, 27, 52		
	8/70 –	172 black 68 – 12, 40, 50		
	8/71 –	35S bordeaux red 72 – 19, 57		
	8/71 –	59S lapis blue 72 – 15, 56		
	8/71 –	81S leather beige 72 – 14, 55		

-	315 867 016	Trim panel - Door, right from Ch. No. 221 975 to 315 220 883	1	315-318, 365-368
	8/63 - 7/64	665 light grey/grey - 70		
	8/63 - 7/64	862 hemp beige/brown - 71		
	8/63 - 7/64	867 sea gull grey/green - 72		
	8/64 - 7/65	868 Oxford grey/dolomite grey - 53, 83		
	8/64 - 7/65	869 pampas green/Burma green - 52, 86		
5	315 867 016 E	Trim panel - Door, right from Ch. No. 316 000 001	1	315-318, 365-368; M 233 M 237: 311-318, 365-368
	8/65 - 7/70	721 platinum 69 - 05, 19, 22, 38, 50, 55, 74, 76		
	8/69 - 7/70	045 capri blue 68 - 21		
	8/69 - 7/70	718 nut brown 69 - 48		
	8/69 - 7/71	719 gala red 69 - 18, 20, 47		
	8/70 - 7/71	50V blue 71 - 16		
	8/70 - 7/71	80V cork 71 - 22, 53		
	3/66 -	172 black 68 - 08, 37, 40, 50, 76, 88		
	8/70 -	71V alabaster 71 - 03, 17, 52		
	8/71 -	35S bordeaux red 72 - 10, 57		
	8/71 -	59S lapis blue 72 - 05, 56		
	8/71 -	81S leather beige 72 - 38, 55		
6	N 14 389 3	Clip	40	
7	113 857 219 A	Rubber cap - Clip	40	
-	311 867 035	Trim panel - Quarter panel, upper, left to Ch. No. 221 974	1	
	4/61 - 7/63	466 silver beige		
-	311 867 037	Trim panel - Quarter panel, lower, left to Ch. No. 221 974	1	311-314
	4/61 - 7/63	124 black-white		
-	361 867 037	Trim panel, lower, left to Ch. No. 221 974	1	361-364
	4/61 - 7/63	124 black-white		
-	311 867 038	Trim panel - Quarter panel, lower, right to Ch. No. 221 974	1	311-314
	4/61 - 7/63	124 black-white		
-	361 867 038	Trim panel - Quarter panel, lower, right to Ch. No. 221 974	1	361-364
	4/61 - 7/63	124 black-white		
-	311 867 043	Trim panel - Quarter panel, upper, left from Ch. No. 221 975 to 315 220 883	1	311-314, 361-364
	8/63 - 7/64	573 light grey - 50, 70, 73		
	8/63 - 7/64	791 hemp beige - 51, 52, 71, 72		
	8/64 - 7/65	384 pampas green - 52, 86		
	8/64 - 7/65	597 Oxford grey - 53, 83, 87		
-	311 867 043 A	Trim panel - Quarter panel, upper, left from Ch. No. 316 000 001 to 316 500 000	1	311-314, 361-364
	8/65 - 7/66	041 black - 80		
	8/65 - 7/66	637 azure - 54		
	8/65 - 7/66	651 pigalle - 79		
	8/65 - 7/66	667 Balearic beige - 81		
	8/65 - 7/66	671 teak - 51		
	8/65 - 7/66	697 platinum - 50, 78		



-	311 867 043 B	Trim panel - Quarter panel, upper, left	1	311-314, 361-364
	8/66 - 7/67	from Ch. No. 317 000 001 to 317 500 000		
		041 black - 92		
	8/66 - 7/67	637 azure - 54		
	8/66 - 7/67	667 Balearic beige - 93		
	8/66 - 7/67	671 teak - 51		
	8/66 - 7/67	697 platinum - 50, 90		
	8/66 - 7/67	752 Indian red - 91		
	8/66 - 7/67	762 khaki brown - 52		
-	311 867 043 C	Trim panel - Quarter panel, left		
		from Ch. No. 318 000 001 to 318 149 518	1	M 239: 311-314
		from Ch. No. 318 149 519 to 318 500 000	1	311-314; M 234
	8/67 - 7/68	945 Capri blue 68 - 04		
	8/67 - 7/68	964 khaki brown 68 - 03, 32		
	8/67 - 7/68	172 black 68 - 08, 43		
	8/67 - 7/68	173 Indian red 68 - 02, 42		
	8/67 - 7/68	176 light sand 68 - 31		
	8/67 - 7/68	697 platinum - 01		
-	311 867 043 D	Trim panel - Quarter panel, left	1	311-314; M 234
		from Ch. No. 319 000 001		
	8/68 - 7/70	045 Capri blue 68 - 14		
	8/68 - 7/70	717 quick grey 69 - 13		
	8/68 - 7/70	718 nut brown 69 - 15, 48		
	8/68 - 7/70	720 cream white 69 - 46		
	8/68 - 7/71	719 gala red 69 - 01, 47		
	8/70 - 7/71	50V blue 71 - 26		
	8/70 - 7/71	80V cork 71 - 28, 53		
	8/68 -	172 black 68 - 12, 40, 50		
	8/70 -	71V alabaster 71 - 13, 27, 52		
	8/71 -	35S bordeaux red 72 - 19, 57		
	8/71 -	59S lapis blue 72 - 15, 56		
	8/71 -	81S leather beige 72 - 14, 55		
-	315 867 043	Trim panel - Quarter panel, left	1	315-318
		from Ch. No. 221 975 to 315 220 883		
	8/63 - 7/64	665 light grey/grey - 70		
	8/63 - 7/64	862 hemp beige/brown - 71		
	8/63 - 7/64	867 sea gull grey/green - 72		
	8/64 - 7/65	868 Oxford grey/dolomite grey - 53, 83		
	8/64 - 7/65	869 pampas green/Burma green - 52, 86		
-	315 867 043 A	Trim panel - Quarter panel, left	1	315-318
		from Ch. No. 316 500 000 to 317 500 000		
	8/65 - 7/67	697 platinum - 55, 74, 86		
	3/66 - 7/67	941 black - 76, 88		

-	315 867 043 B	Trim panel - Quarter panel, upper, left from Ch. No. 317 000 001 to 317 500 000	1	M 234
	8/66 - 7/67	041 black - 92		
	8/66 - 7/67	637 azure - 54		
	8/66 - 7/67	667 Balearic beige - 93		
	8/66 - 7/67	671 teak - 51		
	8/66 - 7/67	697 platinum - 50, 90		
	8/66 - 7/67	752 Indian red - 91		
	8/66 - 7/67	762 khaki brown - 52		
-	315 867 043 C	Trim panel - Quarter panel, left from Ch. No. 318 000 001	1	315-318; M 233; M 237: 311-318
	8/67 - 7/70	721 platinum 69 - 05, 19, 22, 38, 50		
	8/69 - 7/70	045 capri blue 68 - 21		
	8/69 - 7/70	718 nut brown 69 - 48		
	8/69 - 7/71	719 gala red 69 - 18, 20, 47		
	8/70 - 7/71	50V blue 71 - 16		
	8/70 - 7/71	80V cork 71 - 22, 53		
	8/67 -	172 black 68 - 08, 37, 40, 50		
	8/70 -	71V alabaster 71 - 03, 17, 52		
	8/71 -	35S bordeaux red 72 - 10, 57		
	8/71 -	59S lapis blue 72 - 05, 56		
	8/71 -	81S leather beige 72 - 38, 55		
-	361 867 043 B	Trim panel - Quarter panel, upper, left from Ch. No. 318 000 001 to 318 149 518 from Ch. No. 368 149 519 use 311 857 405 (043) for model 365-368	1 1	311-314, 361-368; M 234 361-368; M 237: 365-368
	8/67 - 7/68	064 khaki brown - 03, 32		
	8/67 - 7/68	173 Indian red 68 - 02, 42		
	8/67 - 7/68	176 light sand 68 - 31		
	8/67 - 7/68	697 platinum - 01, 05, 38		
	8/67 - 7/70	045 Capri blue 68 - 04, 14		
	8/68 - 7/70	717 quick grey 69 - 13		
	8/68 - 7/70	718 nut brown 69 - 15, 48		
	8/68 - 7/70	720 cream white 69 - 46		
	8/68 - 7/70	721 platinum 69 - 19, 22, 50		
	8/68 - 7/71	719 gala red 69 - 01, 47		
	8/70 - 7/71	50V blue 71 - 21		
	8/70 - 7/71	80V cork 71 - 28, 53		
	8/67 -	172 black 68 - 08, 12, 37, 40, 43, 50		
	8/70 -	71V alabaster 71 - 03, 13, 17, 27, 52		
	8/71 -	35S bordeaux red 72 - 10, 19, 57		
	8/71 -	59S lapis blue 72 - 05, 15, 56		
	8/71 -	81S leather beige 72 - 14, 38, 55		

-	365 867 043	Trim panel - Quarter panel, upper, left from Ch. No. 221 975 to 315 220 883	1	365-368
	8/63 - 7/64	347 sea gull grey - 72		
	8/63 - 7/64	573 light grey - 70		
	8/64 - 7/65	384 pampas green - 52, 86		
	8/64 - 7/65	597 Oxford grey - 53, 83		
-	365 867 043 C	Trim panel - Quarter panel, upper, left from Ch. No. 366 000 001 to 367 500 000	1	365-368
	8/65 - 7/67	697 platinum - 55, 74, 86		
	3/66 - 7/67	041 black - 76, 88		
8	311 867 044	Trim panel - Quarter panel, upper, right from Ch. No. 221 975 to 315 220 883	1	311-314, 361-364
	8/63 - 7/64	573 light grey - 50, 70, 73		
	8/63 - 7/64	791 hemp beige - 51, 52, 71, 72		
	8/64 - 7/65	384 pampas green - 52, 86		
	8/64 - 7/65	597 Oxford grey - 53, 83, 87		
9	311 867 044 A	Trim panel - Quarter panel, upper, right from Ch. No. 316 000 001 to 316 500 000	1	311-314, 361-364
	8/65 - 7/66	041 black - 80		
	8/65 - 7/66	637 azure - 54		
	8/65 - 7/66	651 pigalle - 79		
	8/65 - 7/66	667 Balearic beige - 81		
	8/65 - 7/66	671 teak - 51		
	8/65 - 7/66	697 platinum - 50, 78		
-	311 867 044 B	Trim panel - Quarter panel, upper, right from Ch. No. 317 000 001 to 317 500 000	1	311-314, 361-364
	8/66 - 7/67	041 black - 92		
	8/66 - 7/67	637 azure - 54		
	8/66 - 7/67	667 Balearic beige - 93		
	8/66 - 7/67	671 teak - 51		
	8/66 - 7/67	697 platinum - 50, 90		
	8/66 - 7/67	752 Indian red - 91		
	8/66 - 7/67	762 khaki brown - 52		
-	311 867 044 C	Trim panel - Quarter panel, right from Ch. No. 318 000 001 to 318 149 518	1	M 239: 311-314
		from Ch. No. 318 149 519 to 318 500 000	1	311-314; M 234
	8/67 - 7/68	045 Capri blue 68 - 04		
	8/67 - 7/68	064 khaki brown 68 - 03, 32		
	8/67 - 7/68	● 172 black 68 - 08, 43 <b>superseded by: 311 867 044 D (172)</b>		
	8/67 - 7/68	173 Indian red 68 - 02, 42		
	8/67 - 7/68	176 light sand 68 - 31		
	8/67 - 7/68	697 platinum - 01		
- 10	311 867 044 D	Trim panel - Quarter panel, right from Ch. No. 319 000 001	1	311-314; M 234
	8/68 - 7/70	045 Capri blue 68 - 14		
	8/68 - 7/70	717 quick grey 69 - 13		

8/68 - 7/70	718 nut brown 69 - 15, 48		
8/68 - 7/70	720 cream white 69 - 46		
8/68 - 7/71	719 gala red 69 - 01, 47		
8/70 - 7/71	50V blue 71 - 26		
8/70 - 7/71	80V cork 71 - 28, 53		
8/68 -	172 black 68 - 12, 40, 50		
8/70 -	71V alabaster 71 - 13, 27, 52		
8/71 -	35S bordeaux red 72 - 19, 57		
8/71 -	59S lapis blue 72 - 15, 56		
8/71 -	81S leather beige 72 - 14, 55		
- 315 867 044	Trim panel - Quarter panel, right from Ch. No. 221 975 to 315 220 883	1	315-318
8/63 - 7/64	665 light grey/grey - 70		
8/63 - 7/64	862 hemp beige/brown - 71		
8/63 - 7/64	867 sea gull grey/green - 72		
8/64 - 7/65	868 Oxford grey/dolomite grey - 53, 83		
8/64 - 7/65	869 pampas green/Burma green - 52, 86		
- 315 867 044 A	Trim panel - Quarter panel, right from Ch. No. 316 000 001 to 317 500 000	1	315-318
8/65 - 7/67	697 platinum - 55, 74, 86		
3/66 - 7/67	041 black - 76, 88		
- 315 867 044 B	Trim panel - Quarter panel, upper, right from Ch. No. 317 000 001 to 317 500 000	1	M 234
8/66 - 7/67	041 black - 92		
8/66 - 7/67	637 azure - 54		
8/66 - 7/67	667 Balearic beige - 93		
8/66 - 7/67	671 teak - 51		
8/66 - 7/67	697 platinum - 50, 90		
8/66 - 7/67	752 Indian red - 91		
8/66 - 7/67	762 khaki brown - 52		
11 315 867 044 C	Trim panel - Quarter panel, right from Ch. No. 318 000 001	1	315-318; M 233; M 237; 311-318
8/67 - 7/70	721 platinum 69 - 05, 19, 22, 38, 50		
8/69 - 7/70	045 capri blue 68 - 21		
8/69 - 7/70	718 nut brown 69 - 48		
8/69 - 7/71	719 gala red 69 - 18, 20, 47		
8/70 - 7/71	50V blue 71 - 16		
8/70 - 7/71	80V cork 71 - 22, 53		
8/67 -	172 black 68 - 08, 37, 40, 50		
8/70 -	71V alabaster 71 - 03, 17, 52		
8/71 -	35S bordeaux red 72 - 38, 55		
8/71 -	59S lapis blue 72 - 05, 56		
8/71 -	81S leather beige 72 - 10, 57		

12	361 867 044 B	Trim panel – Quarter panel, upper, right from Ch. No. 318 000 001 to 318 149 518	1	311-314, 361-368; M 234
		from Ch. No. 368 149 519	1	361-368; M 237; 365-368
	8/67 – 7/68	064 khaki brown 68 – 03, 32		
	8/67 – 7/68	173 Indian red 68 – 02, 42		
	8/67 – 7/68	176 light sand 68 – 31		
	8/67 – 7/68	697 platinum – 01, 05, 38		
	8/67 – 7/70	045 Capri blue 68 – 04, 14		
	8/68 – 7/70	717 quick grey 69 – 13		
	8/68 – 7/70	718 nut brown 69 – 15, 48		
	8/68 – 7/70	720 cream white 69 – 46		
	8/68 – 7/70	721 platinum 69 – 19, 20, 50		
	8/68 – 7/71	719 gala red 69 – 01, 47		
	8/70 – 7/71	50V blue 71 – 26		
	8/70 – 7/71	80V cork 71 – 28, 53		
	8/67 –	172 black 68 – 08, 12, 37, 40, 43, 50		
	8/70 –	71V alabaster 71 – 03, 13, 17, 27, 52		
	8/71 –	35S bordeaux red 72 – 10, 19, 57		
	8/71 –	59S lapis blue 72 – 05, 15, 56		
	8/71 –	81S leather beige 72 – 14, 38, 55		
13	365 867 044	Trim panel – Quarter panel, upper, right from Ch. No. 221 975 to 315 220 883	1	365-368
	8/63 – 7/64	347 sea gull green – 72		
	8/63 – 7/64	573 light grey – 70		
	8/63 – 7/64	791 hemp beige – 71		
	8/64 – 7/65	384 pampas green – 52, 86		
	8/64 – 7/65	597 Oxford grey – 53, 83		
–	365 867 044 E	Trim panel – Quarter panel, upper, right from Ch. No. 366 000 001 to 367 500 000	1	365-368
	8/65 – 7/67	697 platinum – 55, 74, 86		
	3/66 – 7/67	041 black – 76, 88		
–	311 867 045 A	Trim panel – Quarter panel, lower, left from Ch. No. 221 975 to 317 500 000	1	311-314; M 234
	8/63 – 7/64	002 green – 52, 72		
	8/63 – 7/64	049 brown – 51, 71		
	8/63 – 7/65	797 oxide red – 73, 87		
	8/64 – 7/65	753 dolomite grey – 53, 83		
	8/64 – 7/65	754 Burma green – 52, 86		
	8/65 – 7/66	651 pigalle – 79		
	8/65 – 7/67	041 black – 80, 92		
	8/65 – 7/67	637 azure – 54		
	8/65 – 7/67	667 Balearic beige – 81, 93		
	8/65 – 7/67	671 teak – 51		
	8/65 – 7/67	●697 platinum – 50, 78, 90		
		<b>superseded by: 311 867 045 B (697)</b>		
	8/66 – 7/67	752 Indian red – 91		
	8/66 – 7/67	762 khaki brown – 52		

-	311 867 045 B	Trim panel - Quarter panel, lower, left	1	311-314; M 234
	8/67 - 2/68	045 Capri blue 68 - 04		
	8/67 - 2/68	064 khaki brown 68 - 03, 32		
	8/67 - 2/68	172 black 68 - 08, 43		
	8/67 - 2/68	173 Indian red 68 - 02, 42		
	8/67 - 2/68	176 light sand 68 - 31		
	8/67 - 2/68	697 platinum - 01		
-	361 867 045 A	Trim panel - Quarter panel, lower, left	1	361-364
		from Ch. No. 221 975		
	8/63 - 7/64	002 green - 52, 72		
	8/63 - 7/64	049 brown - 51, 71		
	8/63 - 7/64	528 grey - 50, 70		
	8/63 - 7/65	797 oxide red - 73, 87		
	8/64 - 7/65	753 dolomite grey - 53, 83		
	8/64 - 7/65	754 Burma green - 52, 86		
	8/65 - 7/66	651 pigalle - 79		
	8/65 - 7/67	637 azure - 54		
	8/65 - 7/67	667 Balearic beige - 81, 93		
	8/65 - 7/67	671 teak - 51		
	8/65 - 7/67	697 platinum - 50, 78, 90		
	8/66 - 7/67	752 Indian red - 91		
	8/66 - 7/67	762 khaki brown - 52		
	8/67 - 7/68	064 khaki brown 68 - 03, 32		
	8/67 - 7/68	173 Indian red 68 - 02, 42		
	8/67 - 7/68	176 light sand 68 - 31		
	8/67 - 7/68	697 platinum - 01		
	8/67 - 7/70	045 Capri blue 68 - 04, 14		
	8/68 - 7/70	717 quick grey 69 - 13		
	8/68 - 7/70	718 nut brown 69 - 15, 48		
	8/68 - 7/70	720 cream white 69 - 46		
	8/68 - 7/71	719 gala red 69 - 01, 47		
	8/70 - 7/71	50V blue 71 - 26		
	8/70 - 7/71	80V cork 71 - 28, 53		
	8 65 -	172 black 68 - 08, 12, 40, 43, 50, 80, 92		
	8/70 -	71V alabaster 71 - 13, 27, 52		
	8 71 -	35S bordeaux red 72 - 19, 57		
	8/71 -	59S lapis blue 72 - 15, 56		
	8 71 -	81S leather beige 72 - 14, 55		
-	365 867 045	Trim panel - Quarter panel, lower, left	1	365-368 ;M 237: 365-368
		from Ch. No. 221 975		
	8/63 - 7/64	002 green - 72		
	8/63 - 7/64	049 brown - 71		
	8/63 - 7/64	528 grey - 70		
	8/64 - 7/65	754 Burma green - 52, 86		
	8/68 - 7/70	721 platinum 69 - 05, 19, 22, 38, 50, 55, 74, 86		
	8/69 - 7/70	045 capri blue 68 - 21		

	8/69 - 7/70	718 nut brown 69 - 48		
	8/69 - 7/71	719 gala red 69 - 18, 20, 47		
	8/70 - 7/71	50V blue 71 - 16		
	8/70 - 7/71	80V cork 71 - 22, 53		
	3/66 -	172 black 68 - 08, 37, 40, 50, 76, 88		
	8/70 -	71V alabaster 71 - 03, 17, 52		
	8/71 -	355 bordeaux red 72 - 10, 57		
	8/71 -	59S lapis blue 72 - 05, 56		
	8/71 -	81S leather beige 72 - 38, 55		
14	311 867 046 A	Trim panel - Quarter panel, lower, right	1	311-314, M 234
		from Ch. No. 221 975 to 317 500 000		
	8/63 - 7/64	002 green - 52, 72		
	8/63 - 7/64	049 brown - 51, 71		
	8/63 - 7/65	797 oxide red - 73, 87		
	8/64 - 7/65	754 Burma green - 52, 86		
	8/65 - 7/66	651 pigalle - 79		
	8/65 - 7/67	●041 black - 80, 92		
		<b>superseded by: 311 867 046 B (172)</b>		
	8/65 - 7/67	637 azure - 54		
	8/65 - 7/67	667 Balearic beige - 81, 93		
	8/65 - 7/67	671 teak - 51		
	8/65 - 7/67	697 platinum - 50, 78, 90		
	8/66 - 7/67	752 Indian red - 91		
	8/66 - 7/67	762 khaki brown - 52		
-	311 867 046 B	Trim panel - Quarter panel, lower, right	1	311-314
		from Ch. No. 318 000 001 to 318 149 518		
	8/67 - 2/68	045 Capri blue 68 - 04		
	8/67 - 2/68	064 khaki brown 68 - 03, 32		
	8/67 - 2/68	172 black 68 - 08, 43		
	8/67 - 2/68	173 Indian red 68 - 02, 42		
	8/67 - 2/68	176 light sand 68 - 31		
	8/67 - 2/68	697 platinum - 01		
15	361 867 046 A	Trim panel - Quarter panel, lower, right	1	361-364
		from Ch. No. 221 975		
	8/63 - 7/64	002 green - 52, 72		
	8/63 - 7/64	049 brown - 51, 71		
	8/63 - 7/65	797 oxide red - 73, 87		
	8/64 - 7/65	753 dolomite grey - 53, 83		
	8/64 - 7/65	754 Burma green - 52, 86		
	8/65 - 7/66	651 pigalle - 79		
	8/65 - 7/67	637 azure - 54		
	8/65 - 7/67	667 Balearic beige - 81, 93		
	8/65 - 7/67	671 teak - 51		
	8/65 - 7/67	697 platinum - 50, 78, 90		
	8/66 - 7/67	752 Indian red - 91		
	8/66 - 7/68	064 khaki brown 68 - 03, 32, 52		
	8/67 - 7/68	173 Indian red 68 - 02, 42		
	8/67 - 7/68	176 light sand 68 - 31		

	8/67 - 7/68	697 platinum - 01		
	8/67 - 7/70	045 Capri blue 68 - 04, 14		
	8/68 - 7/70	717 quick grey 69 - 13		
	8/68 - 7/70	718 nut brown 69 - 15, 48		
	8/68 - 7/70	720 cream white 69 - 46		
	8/68 - 7/71	719 gala red 69 - 01, 47		
	8/70 - 7/71	50V blue 71 - 26		
	8/70 - 7/71	80V cork 71 - 28, 53		
	8/65 -	172 black 68 - 08, 12, 40, 43, 50, 80, 92		
	8/70 -	71V alabaster 71 - 13, 27, 52		
	8/71 -	35S bordeaux red 72 - 19, 57		
	8/71 -	59S lapis blue 72 - 15, 56		
	8/71 -	81S leather beige 72 - 14, 55		
16	365 867 046	Trim panel - Quarter panel, lower, right from Ch. No. 221 975	1	365-368 ; M 237: 365-368
	8/63 - 7/64	002 green - 72		
	8/63 - 7/64	049 brown - 71		
	8/63 - 7/64	528 grey - 70		
	8/64 - 7/65	753 dolomite grey - 53, 83		
	8/64 - 7/65	754 Burma green - 52, 86		
	3/66 - 7/67	041 black - 76, 88		
	8/65 - 7/70	721 platinum 68 - 05, 19, 22, 38, 50, 55, 74, 86		
	8/69 - 7/70	045 capri blue 68 - 21		
	8/69 - 7/70	718 nut brown 69 - 48		
	8/69 - 7/71	719 gala red 69 - 18, 20, 47		
	8/70 - 7/71	50V blue 71 - 16		
	8/70 - 7/71	80V cork 71 - 22, 53		
	8/67 -	172 black 68 - 08, 37, 40, 50		
	8/70 -	71V alabaster 71 - 03, 17, 52		
	8/71 -	35S bordeaux red 72 - 10, 57		
	8/71 -	59S lapis blue 72 - 05, 56		
	8/71 -	81S leather beige 72 - 38, 55		
17	N 14 389 3	Clip	26	311-318, 365-368; M 234
			12	361-364
18	113 857 219 A	Rubber cap - Clip	X	
19	411 867 147	Protective foil for door trim panel	2	
20	311 867 167	Tapping screw 4.2x13 for door trim panel	4	
21	N 11 555 1	Washer 4.3	4	
22	311 867 169	Cap - Tapping screw	4	
	4/61 - 7/65	466 silver beige		
	8/65 - 7/66	651 pigalle - 79		
	8/65 - 7/67	183 light azure - 54		
	8/65 - 7/67	184 light balearic beige - 81, 83		
	8/65 - 7/67	671 teak - 51		



	8/66 - 7/68	182 light khaki brown - 03, 32, 52		
	8/66 - 7/68	752 Indian red - 02, 42, 01		
	8/67 - 7/68	10X light sand 66 dark - 31		
	8/65 - 7/70	180 light platinum - 01, 05, 19, 22, 38, 50, 55, 74, 78, 83, 86, 90		
	8/67 - 7/70	045 Capri blue 68 - 04, 14, 21		
	8/68 - 7/70	717 quick grey 69 - 13		
	8/68 - 7/70	718 nut brown 69 - 15, 48		
	8/68 - 7/70	720 cream white 69 - 46		
	8/68 - 7/71	719 gala red 69 - 01, 20, 47		
	8/70 - 7/71	50V blue 71 - 26		
	8/70 - 7/71	80V cork 71 - 28, 53		
	8/65 -	041 black - 08, 12, 37, 40, 43, 50, 76, 80, 88, 92		
	8/70 -	71V alabaster 71 - 03, 13, 17, 27, 52		
	8/71 -	35S bordeaux red 72 - 10, 19, 57		
	8/71 -	59S lapis blue 72 - 05, 15, 56		
	8/71 -	81S leather beige 72 - 14, 38, 55		
-	311 867 171 A	Arm rest - Door, left to Ch. No. 315 220 883	1	311-314, 361-364
	4/61 - 4/64	469 anthracite - 50, 70, 73		
	5/64 - 7/65	041 black		
	8/63 - 4/64	041 black - 51, 52, 71, 72		
-	311 867 171 B	Arm rest upholstery - Door, left from Ch. No. 316 000 001 to 318 149 518	1	311-314, 361-364; M 234
	8/65 - 12/65	651 pigalle - 79		
	8/65 - 12/65	671 teak - 51		
	8/65 - 2/68	041 black		
23	311 867 172 A	Arm rest - Door, right to Ch. No. 315 220 883	1	311-314, 361-364
	4/61 - 4/64	469 anthracite - 50, 70, 73		
	5/64 - 7/65	041 black		
	8/63 - 4/64	041 black - 51, 52, 71, 72		
24	N 10 210 7	Bolt, hex. hd. M 6x10 K	10	311-314, 361-364
25	N 12 226 2	Spring washer B 6	10	311-314, 361-364
26	311 867 172 B	Arm rest upholstery - Door, right from Ch. No. 316 000 001 to 318 149 518	1	311-314, 361-364; M 234
	8/65 - 12/65	651 pigalle - 79		
	8/65 - 12/65	671 teak - 5		
	8/65 - 2/68	041 black		
-	311 867 173 A	Arm rest - Door, left from Ch. No. 318 000 001 to 318 149 518 from Ch. No. 318 149 519 to 318 500 000	1 1	M 239 311-314, 361-364; M 234
	8/67 - 7/68	10X light sand 66 dark - 31		
	8/67 - 7/68	141 dark platinum - 01		
	8/67 - 7/68	173 Indian red 68 - 02, 42		
	8/67 - 7/68	191 dark khaki brown 68 - 03, 32		
	8/67 - 7/68	750 garda blue - 04		
	8/67 - 7/68	• 172 black 68 - 08, 13, 14, 15, 40, 43, 46, 47, 48 <b>superseded by: 311 867 173 B (172)</b>		

-	311 867 173 B	Arm rest - Door, left from Ch. No. 319 000 001	1	311-314, 361-364; M 234
	8/68 -	172 black 68		
-	311 867 174 A	Arm rest - Door, right from Ch. No. 318 000 001 to 318 149 518	1	M 239
		from Ch. No. 318 149 519 to 318 500 000	1	311-314, 361-364; M 234
	8/67 - 7/68	10X light sand 66 dark - 31		
	8/67 - 7/68	141 dark platinum - 01		
	8/67 - 7/68	173 Indian red 68 - 02, 42		
	8/67 - 7/68	191 dark khaki brown 68 - 03, 32		
	8/67 - 7/68	750 gardo blue - 04		
	8/67 - 7/68	● 172 black 68 - 08, 13, 14, 15, 40, 43, 46, 47, 48		
		<b>superseded by: 311 867 172 B (172)</b>		
27	311 867 174 B	Arm rest - Door, right from Ch. No. 319 000 001	1	311-314, 361-364; M 234
	8/68 -	172 black 68		
-	N 11 006 2	Nut, hex. M 6 to Ch. No. 318 500 000	6	311-314, 361-364; M 234
28	411 867 199	Nut M 6 from Ch. No. 319 000 001	6	311-314, 361-364; M 234
			4	315-318, 365-368; M 233
-	N 12 226 2	Spring washer B 6 to Ch. No. 318 500 000	6	311-314, 361-364; M 234
29	N 12 230 2	Spring washer B 10 from Ch. No. 319 000 001	6	311-314, 361-364; M 234
			4	315-318, 365-368; M 233
-	N 11 695 2	Washer 6.1 to Ch. No. 318 500 000	2	311-314, 361-364; M 234
30	N 11 527 1	Washer A 10.5 from Ch. No. 319 000 001	2	311-314, 361-364; M 234
-	311 867 175 A	Arm rest - Door, left from Ch. No. 316 000 001 to 318 149 518	1	311-314, 361-364; M 234
	8/65 - 12/65	651 pigalle - 79		
	8/65 - 12/65	671 Teak - 51		
	8/65 - 2/68	041 black		
31	311 867 176 A	Arm rest - Door, right from Ch. No. 316 000 001 to 318 149 518	1	311-314, 361-364; M 234
	8/65 - 12/65	671 Teak - 51		
	8/65 - 2/68	041 black		
32	N 13 648 1	Rivet C 8 x 4	6	311-314, 361-364; M 234
33	N 11 695 2	Washer 6.1	6	311-314, 361-364; M 234
34	N 12 255 1	Spring washer B 5	6	311-314, 361-364; M 234
35	N 15 941 1	Tapping screw, hex. hd. A 5.6 x 22	6	311-314, 361-364; M 234
36	N 13 649 1	Rivet C 8 x 22	4	311-314, 361-364; M 234
37	N 12 225 1	Spring washer B 5	4	311-314, 361-364; M 234
38	N 15 942 1	Tapping screw, hex. hd. A 5.6 x 45	4	311-314, 361-364; M 234
39	N 15 424 1	Speed nut A 5.6	6	311-314, 361-364; M 234

40	113 867 171 C	*Arm rest – Door, right from Ch. No. 221 975 to 315 220 883	1	315-318,365-368
	8/63 – 7/64	347 sea gull grey – 72		
	8/63 – 7/64	791 hemp beige – 71		
	8/63 – 7/65	384 pampas green – 52,70,86		
–	113 867 171 D	*Arm rest – Door, right from Ch. No. 315 000 001 to 318 149 518	1	315-318, 365-368
	8/64 – 7/67	180 light platinum – 53,55,74,83,86		
	3/66 – 2/68	● 172 black 68 – 05,38,40,76,88		
		<b>superseded by: 111 867 171 C (172) + 113 867 185 C</b>		
–	114 867 171	*Arm rest – Door, left from Ch. No. 221 975 to 315 220 883	1	315-318, 365-368
	8/63 – 7/64	573 light grey – 70		
	8/63 – 7/64	791 hemp beige – 71		
	8/63 – 7/65	384 pampas green – 52,72,86		
–	114 867 171 A	*Arm rest – Door, left from Ch. No. 315 000 001 to 318 149 518	1	315-318, 365-368
	8/64 – 7/67	180 light platinum – 53,55,74,83,86		
	3/66 – 2/68	172 black 68 – 05,38,50,76,88		
41	111 867 171 C	*Arm rest – Door from Ch. No. 318 000 001 to 318 149 518	2	M 242
		from Ch. No. 318 149 519	2	315-318, 365-368; M 233
	8/67 –	172 black 68 – 05,19,22,38,40,50		
42	315 867 183	Retaining plate – Arm rest from Ch. No. 221 975 to 315 220 883	2	315-318, 365-368
43	111 867 185	Retaining plate – Arm rest from Ch. No. 316 000 001 to 317 500 000	2	315-318, 365-368
–	113 867 185 B	Retaining plate – Arm rest from Ch. No. 318 000 001 to 318 500 000	2	
44	N 12 226 2	Spring washer B 6 to Ch. No. 318 500 000	4	315-318, 365-368
45	N 11 006 2	Nut, hex. M 6 to Ch. No. 318 500 000	4	315-318, 365-368
46	113 867 185 C	Retaining plate – Arm rest from Ch. No. 319 000 001	2	
–	365 867 197	Cap, front for quarter panel arm rest, left from Ch. No. 221 975	1	365-368
47	365 867 198	Cap, front for quarter panel arm rest, right from Ch. No. 221 975	1	365-368
48	311 867 167	Tapping screw 4.2x13 – Cap	2	365-368
49	N 11 555 1	Washer 4.3	2	365-368
50	311 867 169	Cap – Tapping screw from Ch. No. 221 975	2	365-368
	8/63 –	041 black		
51	311 867 199	Speed nut BG 5.6 – Arm rest from Ch. No. 316 000 001 to 318 149 518	4	311-314, 361-364; M 234

-	311 867 235	Plug 32.3 mm dia. - Quarter panel, inner for harness from Ch. No. 311 2000 001	2	311-314, 361-368
-	311 867 281 C	Padded strip - Door, left to Ch. No. 315 220 883 use 311 867 283 B	1	311-414, 361-364
51a	311 867 282 B	Padded strip - Door, right to Ch. No. 315 220 883 (Observe inner door panel shape. See illustration) use 311 867 283 B	1	311-314, 261-364
52	311 867 282 C	Padded strip - Door, right to Ch. No. 315 220 883 (Observe inner door panel shape. See illustration) use 311 867 283 B	1	311-314, 361-364
53	311 867 283	Retaining clip - Padded strip for door to Ch. No. 221 974	8	
54	311 867 283 B	Retaining clip - Padded strip for door from Ch. No. 221 975 to 315 220 883	14	311-314, 361-364
-	311 867 285 B	Padded strip for quarter panel, left to Ch. No. 315 220 883	1	311-314
-	361 867 285 B	Padded strip, front for quarter panel, left to Ch. No. 365 220 883	1	361-364
-	311 867 286 B	Padded strip for quarter panel, right to Ch. No. 315 220 883	1	311-314
55	361 867 286 B	Padded strip, front for quarter panel, right to Ch. No. 365 220 883	1	361-364
56	311 867 289	Retaining clip - Padded strip for quarter panel to Ch. No. 221 974	8 18	311-314 361-364
57	311 867 289 A	Retaining clip - Padded strip for quarter panel to Ch. No. 315 220 883	8 18	311-314 361-364
-	361 867 293	Padded strip, rear for quarter panel, left to Ch. No. 365 220 883	1	361-364
58	361 867 294	Padded strip, rear for quarter panel, right to Ch. No. 365 220 883	1	361-364
59	311 867 329	Cover - Ashtray opening in quarter panel to Ch. No. 317 500 000	2 1	311-314, 361-364 315-318, 365-368

-	311 867 341 B	Arm rest - Quarter panel, left from Ch. No. 316 000 001 to 318 149 518	1	311-314; M 234
	8/65 - 12/65	651 pigalle - 79		
	8/65 - 12/65	671 teak - 51		
	8/65 - 2/68	041 black		
-	311 867 341 C	Arm rest - Quarter panel, left to Ch. No. 315 220 883	1	311-314
	4/64 - 7/65	041 black - 51, 52, 53, 71, 72, 83, 86, 87		
	4/61 - 7/64	469 anthracite - 50, 70, 73		
-	311 867 341 D	Arm rest - Quarter panel, left from Ch. No. 318 000 001 to 318 149 518	1	M 239: 311-314
		from Ch. No. 318 149 519 to 318 500 000	1	311-314; M 234
	8/67 - 7/68	10X light sand 66 dark - 31		
	8/67 - 7/68	141 dark platinum - 01		
	8/67 - 7/68	173 Indian red 68 - 02, 42		
	8/67 - 7/68	191 dark khaki 68 brown - 03, 32		
	8/67 - 7/68	750 garda blue - 04		
	8/67 - 7/68	172 black 68 - 08, 13, 14, 15, 40, 43, 46, 47, 48		
-	311 867 341 E	Arm rest - Quarter panel, left from Ch. No. 319 000 001	1	311-314; M 234
	8/68 -	172 black 68		
-	361 867 341 A	Arm rest - Quarter panel, left to Ch. No. 365 220 883	1	361-364
	4/61 - 7/64	469 anthracite - 50, 70, 73		
-	361 867 341 B	Arm rest - Quarter panel, left from Ch. No. 366 000 001 to 368 149 518	1	361-364
	8/65 - 12/65	651 pigalle - 79		
	8/65 - 2/68	●041 black		
		<b>superseded by: 361 867 341 (041)</b>		
-	361 867 341 C	Arm rest - Quarter panel, left to Ch. No. 365 220 883	1	361-364
	4/64 - 7/65	041 black - 51, 52, 53, 71, 72, 83, 86, 87		
-	361 867 341 F	Arm rest - Quarter panel, left from Ch. No. 368 000 001 to 368 149 518	1	M 239: 361-364
		from Ch. No. 368 149 519	1	361-364
	8/67 - 7/68	10X light sand 66 dark - 31		
	8/67 - 7/68	141 dark platinum - 01		
	8/67 - 7/68	173 Indian red 68 - 02, 42		
	8/67 - 7/68	191 dark khaki 68 brown - 03, 32		
	8/67 - 7/68	750 garda blue - 04		
	8/67 -	172 black 68 - 01, 08, 13, 14, 15, 40, 43, 46, 47, 48		
60	311 867 342 B	Arm rest - Quarter panel, right from Ch. No. 316 000 001 to 318 149 518	1	311-314; M 234
	8/65 - 12/65	651 pigalle - 79		
	8/65 - 12/65	671 teak - 51		
	8/65 - 2/68	041 black		

61	311 867 289	Retaining clip - Quarter panel arm rest to Ch. No. 318 149 518	4	311-314; M 234
-	311 867 342 C	Arm rest - Quarter panel, right to Ch. No. 315 220 883	1	311-314
	4/64 - 7/65	041 black - 51, 52, 53, 71, 72, 83, 86, 87		
	4/61 - 7/64	469 anthracite - 50, 70, 73		
-	311 867 342 D	Arm rest - Quarter panel, right		
		from Ch. No. 318 000 001 to 318 149 518	1	M 239: 311-314
		from Ch. No. 318 149 519 to 318 500 000	1	311-314; M 234
	8/67 - 7/68	10X light sand 66 dark - 31		
	8/67 - 7/68	141 dark platinum - 01		
	8/67 - 7/68	173 Indian red 68 - 02, 42		
	8/67 - 7/68	191 khaki brown 68 dark - 03, 32		
	8/67 - 7/68	750 garda blue - 04		
-	N 11 695 2	Washer 6.1	4	311-314; M 234
-	N 12 226 2	Spring washer B 6	4	311-314; M 234
-	N 11 006 2	Nut, hex. M 6	4	311-314; M 234
62	311 867 342 E	Arm rest - Quarter panel, right		
		from Ch. No. 318 000 001 to 318 149 518	1	M 239: 311-314
		from Ch. No. 318 149 519	1	311-314; M 234
	8/67 -	172 black 68		
63	N 11 527 1	Washer A 10.5	4	311-314; M 234
64	N 12 230 2	Spring washer B 10	4	311-314; M 234
65	411 867 199	Nut M 6	4	311-314; M 234
-	361 867 342 A	Arm rest - Quarter panel, right to Ch. No. 315 220 883	1	361-364
	4/61 - 7/65	469 anthracite - 50, 70, 73		
-	361 867 342 B	Arm rest - Quarter panel, right	1	361-364
		from Ch. No. 366 000 001 to 368 149 518		
	8/65 - 12/65	651 pigalle - 79		
	8/65 - 2/68	041 black		
-	361 867 342 C	Arm rest - Quarter panel, right to Ch. No. 315 220 883	1	361-364
	4/64 - 7/65	041 black - 51, 52, 53, 71, 72, 83, 86, 87		
66	361 867 342 F	Arm rest - Quarter panel, right		
		from Ch. No. 368 000 001 to 368 149 518	1	M 239: 361-364
		from Ch. No. 368 149 519	1	361-364
	8/67 - 7/68	10X light sand 66 dark - 31		
	8/67 - 7/68	141 dark platinum - 01		
	8/67 - 7/68	173 Indian red 68 - 02, 42		
	8/67 - 7/68	191 khaki brown 68 dark - 03, 32		
	8/67 - 7/68	750 garda blue - 04		
	8/67 -	172 black 68 - 01, 08, 13, 14, 15, 40, 43, 46, 47, 48		
67	N 11 652 1	Washer 7	4	361-364
68	N 11 006 2	Nut, hex. M 6	4	361-364
-	365 867 349	Packing for quarter panel arm rest, left from Ch. No. 221 975	1	365-368

69	365 867 350	Packing for quarter panel arm rest, right from Ch. No. 221 975	1	365-368
-	311 867 365 A	Beading - Door opening to Ch. No. 483 592	2	311-314, 361-364
	4/61 - 7/64	466 silver beige		
-	311 867 365 D	Beading - Door opening from Ch. No. 316 000 001 to 319 500 000	2	311-314, 361-364; M 234
	8/65 - 7/66	912 pigalle/cloud white - 79		
	8/65 - 7/67	911 teak/cloud white - 51		
	8/65 - 7/67	914 light balearic beige/cloud white - 81,93		
	8/65 - 7/67	915 light azure/cloud white - 54		
	8/65 - 7/68	900 light platinum/cloud white - 01, 50, 78, 90		
	8/65 - 7/69	● 916 black/cloud white - 08, 40, 43, 80, 92		
		<b>superseded by: 311 867 365 F (041)</b>		
	8/65 - 7/67	917 light khaki brown/cloud white - 52		
	8/66 - 7/69	933 gala red 69/cloud white - 02, 42, 47, 91		
	8/67 - 7/69	928 Capri blue 68/cloud white - 04, 14		
	8/67 - 7/69	● 932 cream white 69/cloud white - 31, 46		
		<b>superseded by: 311 867 365 F (041)</b>		
	8/67 - 7/69	935 nut brown 69/cloud white - 03, 15, 32, 48		
	8/68 - 7/69	934 quick grey 69/cloud white - 13		
-	315 867 365 A	Beading - Door opening to Ch. No. 315 220 883	2	
		from Ch. No. 316 000 001 to 319 500 000	2	315-318, 365-368
	8/63 - 7/64	466 silver beige		
	8/64 - 7/69	● 581 cloud white		
		<b>superseded by: 311 867 365 F (041)</b>		
70	311 867 365 F	Beading - Door opening from Ch. No. 310 2000 001	2	
	8/69 -	041 black		
-	361 867 421	Lining left - Luggage compartment, rear to Ch. No. 365 220 883	1	361-364
	4/61 - 7/64	466 silver beige		
	8/64 - 7/65	581 cloud white		
-	361 867 421 A	Lining left - Luggage compartment, rear from Ch. No. 366 000 001 to 366 500 000	1	361-364
	8/65 - 7/66	046 lava - 80		
	8/65 - 7/66	634 ultra blue - 54		
	8/65 - 7/66	652 scarlet - 79		
	8/65 - 7/66	672 rust - 51		
	8/65 - 7/66	692 atlas grey - 50, 78		
-	361 867 421 B	Lining left - Luggage compartment, rear from Ch. No. 367 000 001	1	361-364
	8/66 - 7/67	041 black - 92		
	8/66 - 7/67	637 azure - 54		
	8/66 - 7/67	667 Balearic beige - 93		
	8/66 - 7/67	671 teak - 51		

8/66 - 7/67	752 Indian red - 91		
8/66 - 7/67	762 khaki brown - 52		
8/66 - 7/68	697 platinum - 01, 50, 90		
8/67 - 7/68	064 khaki brown 68 - 03, 32		
8/67 - 7/68	176 light sand 68 - 31		
8/67 - 7/70	045 Capri blue 68 - 04, 14		
8/68 - 7/70	717 quick grey 69 - 13		
8/68 - 7/70	718 nut brown 69 - 15, 48		
8/68 - 7/70	720 cream white 69 - 46		
8/67 - 7/71	719 gala red 69 - 01, 02, 42, 47		
8/70 - 7/71	50V blue 71 - 26		
8/70 - 7/71	80V cork 71 - 28, 53		
8/67 -	172 black 68 - 08, 12, 40, 43, 50		
8/70 -	71V alabaster 71 - 13, 27, 52		
8/71 -	35S bordeaux red 72 - 19, 57		
8/71 -	59S lapis blue 72 - 15, 56		
8/71 -	81S leather beige 72 - 14, 55		
- 361 867 421 C	Lining left - Luggage compartment, rear from Ch. No. 362 2000 001	1	M 299: 361-364
8/71 -	35S bordeaux red 72 - 19, 57		
8/71 -	59S lapis blue 72 - 15, 56		
8/71 -	81S leather beige 72 - 14, 55		
8/71 -	71V alabaster 71 - 13, 52		
8/71 -	172 black 68 - 12, 50		
- 365 867 421 A	Lining left - Luggage compartment, rear from Ch. No. 221 975 to 365 220 883	1	365-368
8/63 - 7/64	466 silver beige		
8/64 - 7/65	581 cloud white		
- 365 867 421 C	Lining left - Luggage compartment, rear from Ch. No. 366 000 001	1	365-368
8/65 - 7/71	692 atlas grey - 05, 19, 22, 38, 50, 55, 74, 83, 86		
3/66 - 7/66	046 lava - 76		
8/67 -	172 black 68 - 03, 40, 50, 52, 88		
- 365 867 421 D	Lining left - Luggage compartment, rear from Ch. No. 362 2000 001	1	M 299: 365-368
8/71 -	172 black 68 - 03, 05, 10, 37, 38, 50, 52, 55, 56, 57		
71 361 867 422	Lining right - Luggage compartment, rear to Ch. No. 365 220 883	1	361-364
4/61 - 7/64	466 silver beige		
8/64 - 7/65	581 cloud white		
- 361 867 422 A	Lining right - Luggage compartment, rear from Ch. No. 366 000 001 to 366 500 000	1	361-364
8/65 - 7/66	046 lava - 80		
8/65 - 7/66	634 ultra blue - 54		
8/65 - 7/66	652 scarlet - 79		
8/65 - 7/66	672 rust - 51		
8/65 - 7/66	692 atlas grey - 50, 78		



72	361 867 422 B	Lining right – Luggage compartment, rear from Ch. No. 367 000 001	1	361-364
	8/66 – 7/67	041 black – 92		
	8/66 – 7/67	637 azure – 54		
	8/66 – 7/67	667 Balearic beige – 93		
	8/66 – 7/67	671 teak – 51		
	8/66 – 7/67	752 Indian red – 91		
	8/66 – 7/67	762 khaki brown – 52		
	8/66 – 7/68	697 platinum – 01, 50, 90		
	8/67 – 7/68	064 khaki brown 68 – 03, 32		
	8/67 – 7/68	173 Indian red 68 – 02, 42		
	8/67 – 7/68	176 light sand 68 – 31		
	8/67 – 7/70	045 Capri blue 68 – 04, 14		
	8/68 – 7/70	717 quick grey 69 – 13		
	8/68 – 7/70	718 nut brown 69 – 15, 48		
	8/68 – 7/70	720 cream white 69 – 46		
	8/68 – 7/71	719 gala red 69 – 01, 47		
	8/70 – 7/71	50V blue 71 – 26		
	8/70 – 7/71	80V cork 71 – 28, 53		
	8/67 –	172 black 68 – 08, 12, 40, 43, 50		
	8/70 –	71V alabaster 71 – 13, 27, 52		
	8/71 –	35S bordeaux red 72 – 19, 57		
	8/71 –	59S lapis blue 72 – 15, 56		
	8/71 –	81S leather beige 72 – 14, 55		
–	361 867 422 C	Lining right – Luggage compartment, rear from Ch. No. 362 2000 001	1	M 299: 361-364
	8/71 –	35S bordeaux red 72 – 19, 57		
	8/71 –	59S lapis blue 72 – 15, 56		
	8/71 –	81S leather beige 72 – 14, 55		
	8/71 –	71V alabaster 71 – 13, 52		
	8/71 –	172 black 68 – 12, 50		
–	365 867 422 A	Lining right – Luggage compartment, rear from Ch. No. 221 975 to 365 220 883	1	365-368
	8/63 – 7/64	466 silver beige		
	8/64 – 7/65	581 cloud white		
–	365 867 422 B	Lining right – Luggage compartment, rear from Ch. No. 366 000 001 to 367 500 000	1	365-368
	3/66 – 7/66	046 lava – 76		
–	365 867 422 C	Lining right – Luggage compartment, rear from Ch. No. 366 000 001	1	365-368
	8/65 – 7/71	692 atlas grey – 05, 19, 22, 38, 50, 55, 74, 83, 86		
	8/67 –	172 black 68 – 03, 40, 50, 52, 88		
–	365 867 422 D	Lining right – Luggage compartment, rear from Ch. No. 362 2000 001	1	M 299: 365-368
	8/71 –	172 black 68 – 03, 05, 10, 37, 38, 50, 52, 55, 56, 57		
73	361 867 425	Seal – Clip to Ch. No. 366 500 000	10	361-364

74	361 885 449 A	Clip (clamping width 8.5 mm) to Ch. No. 366 500 000	14	361-364
-	361 867 615	Clip (clamping width 7.8 mm) to Ch. No. 365 220 883	12	365-368
-	361 867 615 B	Clip (clamping width 9 mm) from Ch. No. 366 000 001 to 366 500 000	20	361-368
75	361 867 633	Plastic clip from Ch. No. 367 000 001	28	365-368
76	113 857 219 A	Seal - Clip from Ch. No. 367 000 001	26	365-368
77	N 14 389 3	Clip from Ch. No. 367 000 001	26	361-364
-	361 867 433	Corner lining, rear, right for luggage compartment to Ch. No. 365 220 883	1	361-364
	4/61 - 7/64	466 silver beige		
	8/64 - 7/65	581 cloud white		
78	361 867 434	Corner lining, rear, left for luggage compartment to Ch. No. 365 220 883	1	361-364
	4/61 - 7/64	466 silver beige		
	8/64 - 7/65	581 cloud white		
-	315 867 493	Beading - Vent trim plate from Ch. No. 311 2000 001 (see Illustration A 41)	2	315-318
	8/70 -	581 cloud white		
-	311 867 501 A	Lining - Roof to Ch. No. 315 220 883 from Ch. No. 316 000 001	1 1	311,312,315,316 315,316
	4/61 - 7/64	466 silver beige		
	8/64 -	581 cloud white		
79	311 867 503 A	Lining - Roof from Ch. No. 316 000 001	1	311,312
	8/65 -	581 cloud white		
-	313 867 503	Lining - Roof (steel sliding roof) to Ch. No. 315 220 883 from Ch. No. 316 000 001	1 1	313,314,317,318 317,318
	4/61 -	581 cloud white		
-	313 867 503 A	Lining - Roof (steel sliding roof)	1	313,314
	4/61 -	581 cloud white		
-	361 867 503	Lining - Roof 581 cloud white	1	361,362,365,366
	4/61 -	581 cloud white		
-	363 867 503	Lining - Roof (steel sliding roof) from Ch. No. 221 975 to 366 500 000	1	363,364,367,368
	8/63 - 7/66	466 silver beige		

80	363 867 503 A	Lining - Roof (steel sliding roof) from Ch. No. 367 000 001 581 cloud white	1	363, 364, 367, 368
	8/66 -			
-	361 867 521	Lining - Roof pillar rear, left 466 silver beige 581 cloud white	1	361-364
	4/61 - 7/64			
	8/64 -			
81	361 867 522	Lining - Roof pillar rear, right 581 cloud white	1	361-364
	4/61 -			
82	313 867 525	Felt strip for steel sliding roof frame	1	313, 314, 317, 318, 363, 364, 367, 368
83	361 867 527	Cover plate - Roof rear to Ch. No. 366 500 000	1	361-368
84	N 13 969 1	Tapping screw, fillister hd. B 4.8x16	12	361-368
-	361 867 527 A	Cover plate, left for rear door hinge from Ch. No. 367 000 001	1	361-368
85	361 867 528 A	Cover plate, right for rear door hinge from Ch. No. 367 000 001	1	361-368
86	N 15 891 1	Tapping screw, fillister hd. A 4.9x16	8	361-368
87	311 867 549 A	Retaining spring for tensioning wire 1-6 to Ch. No. 315 220 883		311, 312, 315, 316 361, 362, 365, 366
		from Ch. No. 316 000 001	12	315, 316, 361, 362, 365, 366
-	311 867 549 A	Retaining spring for tensioning wire 2 and 3 to Ch. No. 315 220 883	4	313, 314, 317, 318, 363, 364, 367, 368
		from Ch. No. 316 000 001	4	317, 318, 363, 364, 367, 368
-	313 867 549	Retaining spring for tensioning wire 1 to Ch. No. 315 220 883	2	313, 314, 317, 318, 363, 364, 367, 368
		from Ch. No. 316 000 001	2	317, 318, 363, 364, 367, 368
88	131 867 549	Clip - Tensioning wire mounting from Ch. No. 316 000 001	12	311, 312
			8	313, 314
89	311 867 649	Cap - Tensioning wire from Ch. No. 316 000 001	12	311, 312
			8	313, 314
90	361 867 601	Trim panel - Rear door to Ch. No. 365 220 883	1	361-364
	4/61 - 7/64	466 silver beige		
	8/64 - 7/65	581 cloud white		

-	361 867 603	Trim panel - Rear door	1	361-364
		from Ch. No. 367 000 001 to 367 500 000		
	8/66 - 7/67	041 black - 92		
	8/66 - 7/67	637 azure - 54		
	8/66 - 7/67	667 Balearic beige - 93		
	8/66 - 7/67	671 teak - 51		
	8/66 - 7/67	697 platinum - 50, 90		
	8/66 - 7/67	752 Indian red - 91		
	8/66 - 7/67	762 khaki brown - 52		
91	361 867 603 A	Trim panel - Rear door	1	361-364
		from Ch. No. 368 000 001		
	8/67 - 7/68	064 khaki brown 68 - 03, 32		
	8/67 - 7/68	176 light sand 68 - 31		
	8/67 - 7/68	697 platinum - 01		
	8/67 - 7/70	045 Capri blue 68 - 04, 14		
	8/67 - 7/71	719 gala red 69 - 01, 02, 42, 47		
	8/68 - 7/70	717 quick grey 69 - 13		
	8/68 - 7/70	718 nut brown 69 - 15, 48		
	8/68 - 7/70	720 cream white 69 - 46		
	8/70 - 7/71	50V blue 71 - 26		
	8/70 - 7/71	80V cork 71 - 28, 53		
	8/67 -	172 black 68 - 08, 12, 40, 43, 50		
	8/70 -	71V alabaster 71 - 13, 27, 52		
	8/71 -	35S bordeaux red 72 - 19, 57		
	8/71 -	59S lapis blue 72 - 15, 56		
	8/71 -	81S leather beige 72 - 14, 55		
-	365 867 605	Trim panel - Rear door		
		from Ch. No. 365 000 001 to 365 220 883	1	365-368
		from Ch. No. 366 000 001 to 367 500 000	1	361-368
	8/64 - 7/65	581 cloud white		365-368
	8/65 - 7/66	046 lava - 80		361-364
	8/65 - 7/66	634 ultra blue - 54		361-364
	8/65 - 7/66	652 scarlet - 79		361-364
	8/65 - 7/66	662 almond beige - 81		361-364
	8/65 - 7/66	581 cloud white - 51		361-364
	8/65 - 7/66	692 atlas grey - 50, 55, 78, 83		361-368
	3/66 - 7/66	046 lava - 76		365-368
	8/66 - 7/67	041 black - 88		365-368
	8/66 - 7/67	692 atlas grey - 55, 86		365-368
-	365 867 605 A	Trim panel - Rear door	1	365-368
		from Ch. No. 368 000 001		
	8/67 -	172 black 68 - 40		
	8/67 -	692 atlas grey - 05, 19, 22, 38, 50		
92	361 867 615	Clip (clamping width 7.8 mm)	12	361-368
		to Ch. No. 365 220 883		
-	361 867 615 B	Clip (clamping width 9 mm)	12	361-368
		from Ch. No. 366 000 001 to 366 500 000		

93	N 14 389 3	Clip from Ch. No. 367 000 001	12	361-364
94	113 857 218 A	Seal - Clip	12	361-364
-	361 867 633	Plastic clip from Ch. No. 367 000 001	12	365-368
95	111 867 809	Sound absorbing material - Roof	X	
96	311 867 933 A	Insulation for cover plate, front - Engine compartment	1	
97	311 867 935	Insulation for engine compartment lid	1	
98	311 867 941	Clip	9	
99	311 867 943	Clip - Headlining on parcel shelf, rear from Ch. No. 316 000 001	4	311-314
100	311 705 695	Washer	2	

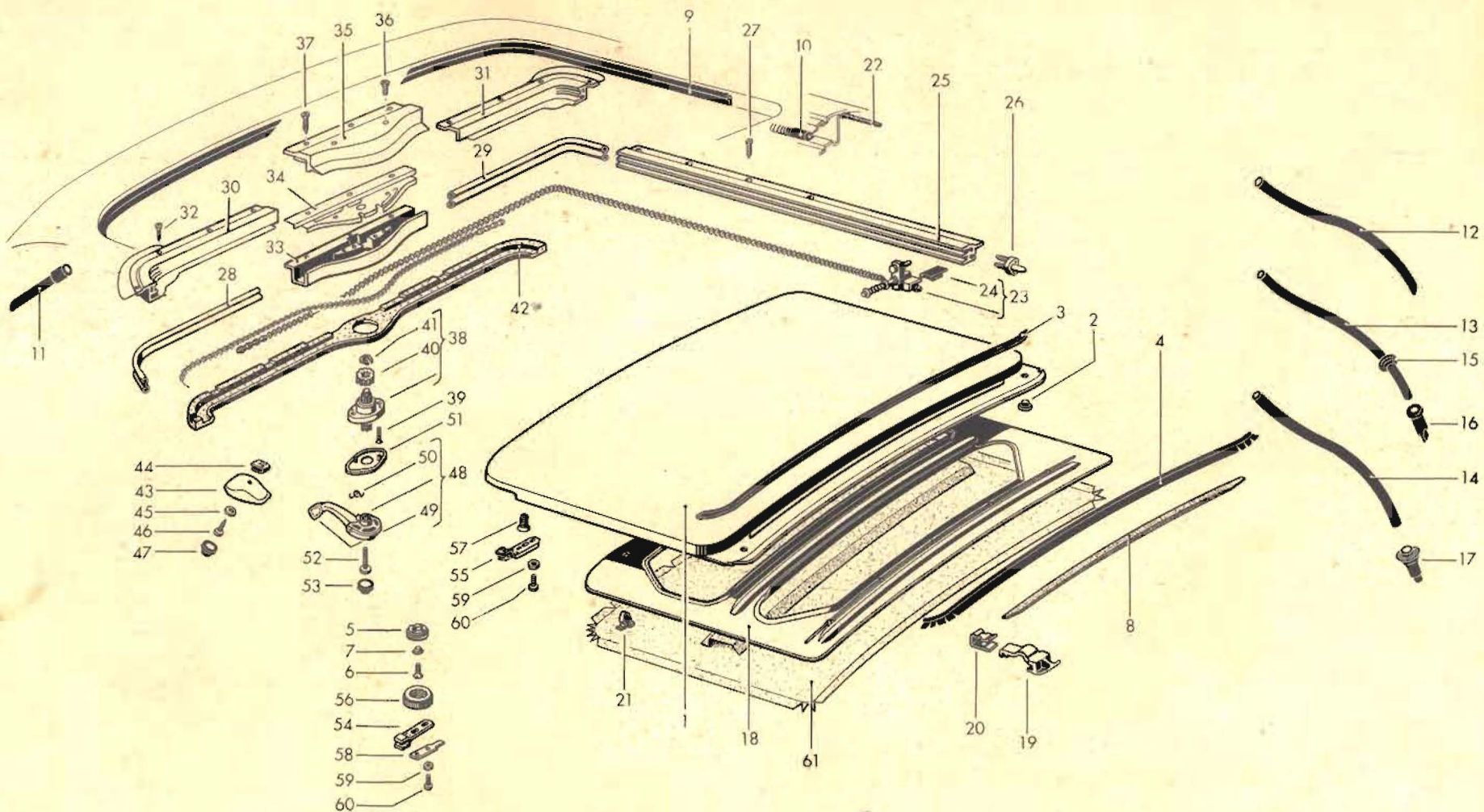

Illustration 51

Type 3

**MAIN GROUP 8**

**BODY**

Key	Part No.	Description	Qty.	Type and model
<b>STEEL SLIDING ROOF</b>				
-	313 877 071 A	Panel for steel sliding roof to Ch. No. 282 175	1	313,314,317,318
1	363 877 071 A	Panel for steel sliding roof from Ch. No. 221 975 to 282 175	1	363, 364, 367, 368
		from Ch. No. 282 176 use 117 877 481 A/497/N 12 225 1/N 14 131 2 to Ch. No. 317 107 625	1	313, 314, 317, 318, 363, 364, 367, 368
2	117 877 205 A	Plug rear for steel sliding roof panel	2	313, 314, 317, 318, 363, 364, 367, 368
-	313 877 209	Weatherstrip (foam rubber) rear for steel sliding roof panel to Ch. No. 282 175	1	313, 314, 317, 318
3	363 877 209	Weatherstrip (foam rubber) rear for steel sliding roof panel from Ch. No. 221 975 to 282 175	1	363, 364, 367, 368
		from Ch. No. 282 176	1	313, 314, 317, 318, 363, 364, 367, 368
4	363 877 213 B	Weatherstrip, rear for steel sliding roof panel	1	313, 314, 317, 318, 363, 364, 367, 368
5	117 877 217 A	Threaded plate M 42x1 from Ch. No. 221 975 to 282 175	2	363, 364, 367, 368
		from Ch. No. 282 176 to 317 107 626	2	313, 314, 317, 318, 363, 364, 367, 368
6	N 14 228 1	Screw, csk. hd. AM 6x12 to Ch. No. 317 107 626	2	313, 314, 317, 318, 363, 364, 367, 368
7	N 12 128 2	Shake-proof washer V 6.4 to Ch. No. 317 107 626	2	313, 314, 317, 318, 363, 364, 367, 368
-	313 877 217	Threaded plate M 32x1 to Ch. No. 282 175	2	313, 314, 317, 318
-	N 14 138 1	Screw, fillister hd. AM 6x10 to Ch. No. 282 175	2	313, 314, 317, 318
-	N 12 105 1	Lock washer A 6.4 to Ch. No. 282 175	2	313, 314, 317, 318
8	117 877 221	Felt strip for sliding roof frame	1	313, 314, 317, 318, 363, 364, 367, 368
9	363 877 223 A	Weatherstrip, front for steel sliding roof panel	1	313, 314, 317, 318, 363, 364, 367, 368
10	313 877 227	Beading, side	2	313, 314, 317, 318, 363, 364, 367, 368

11	363 877 231	Water drain hose, front (shorten to 134 mm) to Ch. No. 315 220 883	2	313, 314, 317, 318, 363, 364, 367, 368
		from Ch. No. 316 000 001 to 316 500 000	2	317, 318, 363, 364, 367, 368
-	363 877 231	Water drain hose, rear from Ch. No. 221 975 to 316 500 000	2	363, 364, 367, 368
12	363 877 231 A	Water drain hose, rear from Ch. No. 317 000 001	2	363, 364, 367, 368
-	363 877 231 A	Water drain hose, front and rear (shorten to 130 mm) from Ch. No. 317 000 001	4	313, 314
-	363 877 231 A	Water drain hose, front (shorten to 130 mm) from Ch. No. 317 000 001	2	317, 318, 363, 364, 367, 368
13	313 877 233	Water drain hose, rear to Ch. No. 315 220 883 from Ch. No. 316 000 001 to 316 500 000	2 2	313, 314, 317, 318 317, 318
14	411 877 233	Water drain hose, rear from Ch. No. 317 000 001	2	317, 318
-	313 877 235	Water drain hose, front and rear from Ch. No. 316 000 001 to 316 500 000	4	313, 314
15	141 971 907	Grommet for water drain hose, rear, in quarter panel to Ch. No. 315 220 883 from Ch. No. 316 000 001	2 2	313, 314, 317, 318 317, 318
16	411 877 241	Rubber valve - Water drain hose from Ch. No. 221 975 to 252 299 from Ch. No. 252 300 to 315 220 883 from Ch. No. 316 000 001 to 316 500 000 from Ch. No. 317 000 001	2 2 2	363, 364, 367, 368 313, 314, 317, 318, 363, 364, 367, 368 317, 318, 363, 364, 367, 368 363, 364, 367, 368
-	313 877 243	Rubber valve - Water drain hose from Ch. No. 316 000 001	2	313, 314
-	135 877 243	Rubber valve - Water drain hose from Ch. No. 317 000 001 to 317 500 000	2	317, 318
17	317 877 243	Rubber valve - Water drain hose from Ch. No. 318 000 001	2	317, 318
18	363 877 259	Frame for roof panel lining from Ch. No. 221 975 to 282 175 from Ch. No. 282 176	1 1	363, 364, 367, 368 313, 314, 317, 318, 363, 364, 367, 368
19	313 877 275	Slide - Frame	2	313, 314, 317, 318, 363, 364, 367, 368
20	313 877 277	Clip - Slide	2	313, 314, 317, 318, 363, 364, 367, 368



21	313 877 281	Clip - Frame	5	313, 314, 317, 318, 363, 364, 367, 368
22	411 877 297	Weatherstrip for steel sliding roof frame	1	313, 314, 317, 318, 363, 364, 367, 368
-	313 877 305	Guide rear left with cable to Ch. No. 282 175	1	313, 314, 317, 318
-	313 877 305 A	Guide rear left with cable from Ch. No. 221 975 to 282 175 from Ch. No. 282 176	1 1	363, 364, 367, 368 313, 314, 317, 318, 363, 364, 367, 368
-	313 877 308	Guide rear right with cable to Ch. No. 282 175	1	313, 314, 317, 318
23	313 877 306 A	Guide rear right with cable from Ch. No. 221 975 to 282 175 from Ch. No. 282 176	1 1	363, 364, 367, 368 313, 314, 317, 318, 363, 364, 367, 368
-	313 877 307	Guide piece - Guides 313 877 305/306	2	313, 314, 317, 318, 363, 364, 367, 368
24	313 877 307 A	Guide piece - Guides 313 877 305 A/306 A	2	313, 314, 317, 318, 363, 364, 367, 368
-	313 877 355	Guide rail, left to Ch. No. 282 175	1	313, 314, 317, 318
-	313 877 355 A	Guide rail, left from Ch. No. 282 176 to 315 170 011 466 silver beige 581 cloud white	1	313, 314, 317, 318
	11/63 - 10/64			
	11/64 - 4/65			
-	313 877 355 B	Guide rail, left from Ch. No. 315 170 012 581 cloud white	1	313, 314, 317, 318
	5/65 -			
-	363 877 355	Guide rail, left from Ch. No. 221 975 to 315 170 011 466 silver beige 581 cloud white	1	363, 364, 367, 368
	8/63 - 10/64			
	11/64 - 4/65			
-	363 877 355 A	Guide rail, left from Ch. No. 315 170 012 581 cloud white	1	363, 364, 367, 368
	5/65 -			
-	313 877 356	Guide rail, right to Ch. No. 282 175	1	313, 314, 317, 318
-	313 877 356 A	Guide rail, right from Ch. 282 176 to 315 170 011 466 silver beige 581 cloud white	1	313, 314, 317, 318
	11/63 - 10/64			
	11/64 - 4/65			
25	313 877 356 B	Guide rail, right from Ch. No. 315 170 012 581 cloud white	1	313, 314, 317, 318
	5/65 -			

-	363 877 356	Guide rail, right from Ch. No. 221 975 to 315 170 011	1	363, 364, 367, 368
	8/63 - 10/64	466 silver beige		
	11/64 - 4/65	581 cloud white		
-	363 877 356 A	Guide rail, right from Ch. No. 315 170 012	1	363, 364, 367, 368
	5/65 -	581 cloud white		
26	313 877 359	Retainer - Guide rail	2	313, 314, 317, 318, 363, 364, 367, 368
27	N 14 085 1	Tapping screw, csk. hd. B 3.5x9.5	8	313, 314, 317, 318, 363, 364, 367, 368
28	313 877 363 A	Cable channel, lower part, left from Ch. No. 315 170 012	1	313, 314, 317, 318, 363, 364, 367, 368
-	313 877 363 B	Cable channel, lower part, left to Ch. No. 315 170 011 use 313 877 385	1	313, 314, 317, 318, 363, 364, 367, 368
29	313 877 364 A	Cable channel, lower part, right from Ch. No. 315 170 012	1	313, 314, 317, 318, 363, 364, 367, 368
-	313 877 364 B	Cable channel, lower part, right to Ch. No. 315 170 011 use 313 877 385	1	313, 314, 317, 318, 363, 364, 367, 368
-	313 877 365	Cable channel, upper part, left to Ch. No. 315 170 011	1	313, 314, 317, 318, 363, 364, 367, 368
	4/81 - 10/64	466 silver beige		
	11/64 - 4/65	581 cloud white		
30	313 877 365 A	Cable channel, upper part, left from Ch. No. 315 170 012	1	313, 314, 317, 318, 363, 364, 367, 368
	5/65 -	581 cloud white		
-	313 877 366	Cable channel, upper part, right to Ch. No. 315 170 011	1	313, 314, 317, 318, 363, 364, 367, 368
	4/61 - 10/64	466 silver beige		
	11/64 - 4/65	581 cloud white		
31	313 877 366 A	Cable channel, upper part, right from Ch. No. 315 170 012	1	313, 314, 317, 318, 363, 364, 367, 368
	5/65 -	581 cloud white		
32	N 14 085 1	Tapping screw, csk. hd. B 3.5x9.5	8	313, 314, 317, 318, 363, 364, 367, 368
33	313 877 369 A	Guide housing - Cable	1	313, 314, 317, 318, 363, 364, 367, 368
34	313 877 373	Reinforcement plate - Guide housing	1	313, 314, 317, 318, 363, 364, 367, 368
-	241 877 373	Tensioning plate - Guide housing	X	313, 314, 317, 318, 363, 364, 367, 368
35	313 877 375 B	Cover - Guide housing	1	313, 314, 317, 318, 363, 364, 367, 368
	4/61 - 10/64	466 silver beige		
	11/64 -	581 cloud white		
36	N 14 255 1	Screw, csk. raised hd. AM 4 x 12	2	313, 314, 317, 318, 363, 364, 367, 368
37	N 14 087 3	Tapping screw, csk. hd. B 3.5 x 16	3	313, 314, 317, 318, 363, 364, 367, 368

-	313 877 385	Packing strip - Channel lower part 313 877 363 B/364 B to Ch. No. 315 170 011	4	313,314,317,318, 363,364,367,368
-	313 877 403	Winding gear to Ch. No. 317 500 000	1	313,314,317,318, 363,364,367,368
38	117 877 403	Winding gear from Ch. No. 318 000 001	1	313,314,317,318, 363,364,367,368
39	N 14 212 2	Screw, csk. AM 4 x 20	2	313,314,317,318, 363,364,367,368
40	313 877 407	Pinion - Winding gear	1	313,314,317,318, 363,364,367,368
41	N 12 405 1	Circlip 5 x 0.6	1	313,314,317,318, 363,364,367,368
-	313 877 411	Packing - Finger plate to Ch. No. 282 175	1	313,314,317,318
42	313 877 415 B	Packing, front under roof lining	1	313,314,317,318, 363,364,367,368
-	313 877 433	Finger plate to Ch. No. 282 175	1	313,314,317,318
43	117 877 433	Finger plate from Ch. No. 221 975 to 282 175	1	363,364,367,368
		from Ch. No. 282 176	1	313,314,317,318, 363,364,367,368
	8/63 - 10/64	466 silver beige		
	11/64 -	581 cloud white		
44	N 15 422 2	Speed nut B 4.2 to Ch. No. 315 220 883	1	313,314,317,318, 363,364,367,368
45	N 12 224 1	Spring washer B 4	1	313,314,317,318, 363,364,367,368
46	311 867 167	Tapping screw 4.2 x 13 Finger plate	1	313,314,317,318, 363,364,367,368
47	311 867 169	Cap - Tapping screw 466 silver beige	1	313,314,317,318, 363,364,367,368
	4/61 - 10/64	581 cloud white		
	11/64 -			
-	313 877 453	Winder to Ch. No. 317 500 000	1	313,314,317,318,363, 364,367,368
	4/61 - 10/64	466 silver beige		
	11/64 - 7/67	581 cloud white		
48	117 877 453	Winder from Ch. No. 318 000 001	1	313,314,317,318,363, 364,367,368
	8/67 -	581 cloud white		
49	313 877 457	Knob - Winder 466 silver beige	1	313,314,317,318,363, 364,367,368
	4/61 - 10/64	581 cloud white		
	11/64 -			
50	313 877 459 A	Spring - Winder	1	313,314,317,318,363, 364,367,368

51	313 877 465 4/61 - 10/64 11/64 -	Escutcheon - Winding gear 466 silver beige 581 cloud white	1	313, 314, 317, 318, 363, 364, 367, 368
-	313 877 471	Screw - Winder to Ch. No. 317 500 000	1	313, 314, 317, 318, 363, 364, 367, 368
52	N 14 257 1	Tapping screw, fillister hd. AM 4x8 from Ch. No. 318 000 001	1	313, 314, 317, 318, 363, 364, 367, 368
53	311 867 169 4/61 - 10/64 11/64 - 7/67	Cap - Tapping screw 466 silver beige 581 cloud white	1	313, 314, 317, 318, 363, 364, 367, 368
-	313 877 481	Guide, front to Ch. No. 282 175	2	313, 314, 317, 318
54	117 877 481	Guide, front from Ch. No. 221 975 to 282 175 from Ch. No. 282 176 to 317 107 625	2 2	363, 364, 367, 368 313, 314, 317, 318, 363, 364, 367, 368
55	117 877 481 A	Guide, front from Ch. No. 317 107 626	2	313, 314, 317, 318, 363, 364, 367, 368
-	313 877 495	Knurled nut M 32x1 to Ch. No. 282 175	2	313, 314, 317, 318
56	117 877 495 A	Knurled nut M 42x1 from Ch. No. 221 975 to 282 175 from Ch. No. 282 176 to 317 107 625	2 2	363, 364, 367, 368 313, 314, 317, 318, 363, 364, 367, 368
57	117 877 497	Screw, csk. M 10x1 from Ch. No. 317 107 626	2	313, 314, 317, 318, 363, 364, 367, 368
58	117 877 499	Lock plate - Guide, front from Ch. No. 221 975 to 282 175 from Ch. No. 282 176 to 317 107 625	2 2	363, 364, 367, 368 313, 314, 317, 318, 363, 364, 367, 368
59	N 12 225 1	Spring washer B 5	4	313, 314, 317, 318, 363, 364, 367, 368
60	N 14 131 2	Screw, fillister hd. AM 5x15	4	313, 314, 317, 318, 363, 364, 367, 368
-	313 877 505 4/61 - 7/64	Roof panel lining to Ch. No. 483 592 466 silver beige	1	313, 314, 317, 318, 363, 364, 367, 368
61	363 877 505 A 8/64 -	Roof panel lining from Ch. No. 315 000 001 581 cloud white	1	313, 314, 317, 318, 363, 364, 367, 368



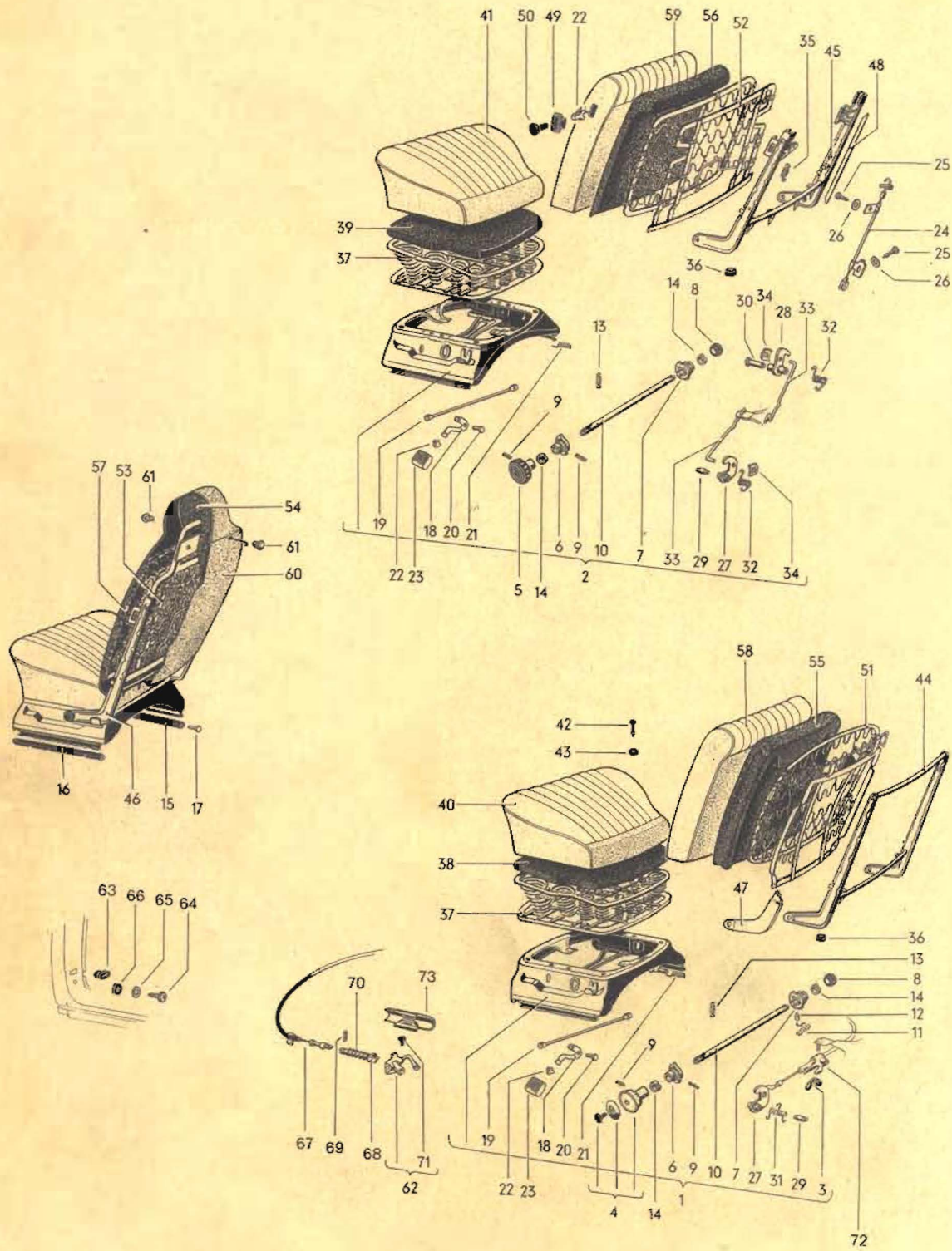

**MAIN GROUP 8**

**BODY**

Key	Part No.	Description	Qty.	Type and model
<b>FRONT SEAT</b>				
-	315 881 032	Seat, front, right (leatherette) from Ch. No. 221 975 to 483 592	1	315-318,365-368
	8/63 - 7/64	299 olive cord pattern/olive - 72		
-	311 881 037	Seat, front, left (with muslin covering) to Ch. No. 317 500 000	1	
-	311 881 037 A	Seat, front, left (with muslin covering) from Ch. No. 318 000 001	1	
-	311 881 038	Seat, front, right (with muslin covering) to Ch. No. 317 500 000	1	
-	311 881 038 A	Seat, front, right (with muslin covering) from Ch. No. 318 000 001	1	
-	312 881 042 A	Backrest - Front seat, right (leatherette) from Ch. No. 221 975 to 483 592	1	312,314,362,364
	8/63 - 7/64	296 brown cord pattern/brown - 71		
	8/63 - 7/64	298 grey cord pattern/grey - 70		
	8/63 - 7/64	299 olive cord pattern/olive - 72		
-	312 881 042 B	Backrest - Front seat, right (cloth) from Ch. No. 221 975 to 483 592	1	312,314,362,364
	8/63 - 7/64	298 grey cord pattern/grey - 50		
	8/63 - 7/64	299 olive cord pattern/olive - 52		
-	316 881 042	Backrest - Front seat, right (leatherette) from Ch. No. 221 975 to 483 592	1	316,318,366,368
	8/63 - 7/64	296 brown cord pattern/brown - 71		
	8/63 - 7/64	298 grey cord pattern/grey - 70		
	8/63 - 7/64	299 olive cord pattern/olive - 72		
-	311 881 047	Backrest - Front seat (with muslin covering) to Ch. No. 315 220 883	2	311,313,315,317, 361,363,365,367
			1	312,314,316,318, 362,364,366,368
-	311 881 047 A	Backrest - Front seat (with muslin covering) from Ch. No. 316 000 001 to 317 180 000	2	311,313,315,317, 361,363,365,367
			1	312,314,316,318, 362,364,366,368
-	311 881 047 D	Backrest - Front seat (with muslin covering) from Ch. No. 317 180 001	2	

-	311 881 047 E	Backrest with headrest - Front seat (with muslin covering) from Ch. No. 318 000 001 to 319 500 000	2	M 258
-	311 881 047 F	Backrest with headrest - Front seat (with muslin covering) from Ch. No. 310 2000 001	2	M 258
-	312 881 048	Backrest - Front seat, right (with muslin covering) to Ch. No. 315 220 883	1	312,314,316,318, 362,364,366,368
-	312 881 048 A	Backrest - Front seat, right (with muslin covering) from Ch. No. 316 000 001 to 317 180 000	1	312,314,316,318, 362,364,366,368
1	311 881 111 C	Base - Front seat, left to Ch. No. 317 500 000	1	
2	311 881 111 E	Base - Front seat, left from Ch. No. 318 000 001	1	
-	311 881 112 C	Base - Front seat, right to Ch. No. 317 500 000	1	
-	311 881 112 E	Base - Front seat, right from Ch. No. 318 000 001	1	
3	141 945 299	Wing nut M 6 to Ch. No. 317 500 000	2	311-314,361-364
4	311 881 155	Knob - Backrest adjustment to Ch. No. 316 500 000	2	
	8/65 - 7/66	652 scarlet - 79		
	8/65 - 7/66	662 almond beige - 81		
	8/65 - 7/66	672 rust - 51		
5	311 881 161 C	Knob - Backrest adjustment from Ch. No. 317 000 001	2	
6	311 881 165 A	Adjusting cams, left - Backrest adjustment	2	
7	311 881 166 A	Adjusting cams, right - Backrest adjustment	2	
8	311 881 171	Cap - Backrest adjustment	2	
	8/65 - 7/66	652 scarlet - 79		
	8/65 - 7/66	662 almond beige - 81		
	8/65 - 7/66	672 rust - 51		
	4/61 -	043 grey-black		
9	N 13 327 1	Pin 3 x 18	8	
10	311 881 175	Connecting pipe - Adjusting cams	2	
11	311 881 177	Engaging spring - Backrest adjustment, left to Ch. No. 182 449	1	
-	311 881 178	Engaging spring - Backrest adjustment, right to Ch. No. 182 449	1	



12	311 881 181	Cap - Engaging spring to Ch. No. 182 449	2	
13	311 881 193	Spring - Connecting pipe	4	
14	311 881 197	Bush - Seat back mounting	4	
15	311 881 213	Cover strip - Runner, inner	2	
16	311 881 215	Cover strip - Runner, outer	2	
17	N 15 193 1	Grooved pin 4 x 18	8	
13	311 881 223	Arm - Locking mechanism	2	
19	311 881 229 A	Connecting rod - Locking mechanism	2	
20	N 13 661 2	Rivet B 4 x 8	6	
-	311 881 243	Spring - Locking device, left to Ch. No. 316 065 183	1	
21	311 881 243 A	Spring - Locking device, left from Ch. No. 316 065 184	1	
-	311 881 244	Spring - Locking device, right to Ch. No. 316 065 183	1	
-	311 881 244 A	Spring - Locking device, right from Ch. No. 316 065 184	1	
22	311 881 247	Clip - Fingerpull	2	
23	315 881 251	Fingerpull - Arm to Ch. No. 315 220 883 from Ch. No. 316 000 001	2 2	315-318,365-368
	4/61 -	043 grey-black		
-	311 881 251 C	Fingerpull - Arm from Ch. No. 316 000 001	2	311-314,361-364
24	311 881 257	Cable - Backrest lock from Ch. No. 318 000 001	2	
25	N 13 965 1	Tapping screw, B 4.2 x 9.5	4	
26	N 12 097 1	Lock washer A 4.3	4	
-	311 881 267	Locking hook to Ch. No. 317 500 000	2	311-314,361-364
27	311 881 267 A	Locking hook, outer from Ch. No. 318 000 001	2	
28	311 881 268	Locking hook, inner from Ch. No. 318 000 001	2	
29	311 881 273	Pin - Locking hooks from Ch. No. 318 000 001	2	311-314,361-364
30	311 881 274	Pin - Locking hooks, inner from Ch. No. 318 000 001	2	
31	311 881 275	Spring - Locking hooks to Ch. No. 317 500 000	2	311-314,361-364

32	311 881 275 A	Spring – Locking hooks from Ch. No. 318 000 001	4	
33	311 881 285	Operating rod – Backrest from Ch. No. 318 000 001	4	
34	N 12 855 1	Clamping plate 5	4	
35	311 881 287 A	Return spring – Backrest lock lever from Ch. No. 318 000 001	2	
36	311 881 295	Buffer – Backrest stop	4	
-	311 881 305 B	Spring core – Front seat (see Workshop Manual A-17) to Ch. No. 317 500 000	X	
37	311 881 305 C	Spring core – Front seat use: to Ch. No. 317 157 344 311 881 375 A	2	
38	311 881 375	Padding – Front seat to Ch. No. 317 157 344	2	
39	311 881 375 A	Padding – Front seat from Ch. No. 317 157 345	2	
-	311 881 405	Cover – Front seat (cloth) to Ch. No. 221 974	2	
	4/61 – 7/63	228 black-white/silver beige		
-	311 881 405 A	Cover – Front seat (leatherette) from Ch. No. 221 975 to 315 220 883	2	311-314,361-364
	8/63 – 7/64	295 red cord pattern/oxide red – 73		
	8/63 – 7/64	296 brown cord pattern/brown – 71		
	8/63 – 7/64	299 olive cord pattern/olive – 72		
	8/64 – 7/65	300 mesh grey/Oxford grey – 83		
	8/64 – 7/65	301 mesh red/oxide red – 87		
	8/64 – 7/65	302 mesh green/pampas green – 86		
-	311 881 405 B	Cover – Front seat (cloth) from Ch. No. 221 975 to 315 220 883	2	311-314,361-364
	8/63 – 7/64	296 brown cord pattern/brown – 51		
	8/63 – 7/64	298 grey cord pattern/grey – 50		
	8/63 – 7/64	299 olive cord pattern/olive – 52		
	8/64 – 7/65	166 olive cord pattern/pampas green – 52		
	8/64 – 7/65	169 silver cord pattern/Oxford grey – 53		
-	311 881 405 C	Cover – Front seat (cloth) from Ch. No. 316 000 001 to 317 157 344	2	311-314,361-364; M 234
	8/65 – 2/67	125 platinum repp./platinum – 50		
	8/65 – 2/67	126 Teak repp./Teak – 51		
	8/65 – 2/67	127 azure repp./azure – 54		
	8/66 – 2/67	AC5 khaki repp./khaki brown – 52		

40	311 881 405 D	Cover - Front seat (leatherette) from Ch. No. 316 000 001 to 316 500 000	2	311-314,361-364
	8/65 - 7/66	041 black/black - 80		
	8/65 - 7/66	651 pigalle/pigalle - 79		
	8/65 - 7/66	667 Balearic beige/Balearic beige - 81		
	8/65 - 7/66	697 platinum/platinum - 78		
-	311 881 405 E	Cover - Front seat (leatherette) from Ch. No. 317 000 001 to 317 157 344	2	311-314,361-364; M 234
	8/66 - 2/67	667 Balearic beige/Balearic beige - 93		
41	311 881 405 F	Cover - Front seat (cloth) from Ch. No. 317 157 345	2	311-314,361-364; M 234
	3/67 - 7/67	126 Teak repp./Teak - 51		
	3/67 - 7/67	127 azure repp./azure - 54		
	3/67 - 7/68	125 platinum repp./platinum - 01, 50		
	3/67 - 7/68	AD1 khaki repp./khaki brown 68 - 03, 52		
	8/67 - 7/68	AD2 blue repp. 68/Capri blue 68 - 04		
	8/67 - 7/68	AD3 red repp. 68/Indian red 68 - 02		
	8/67 - 7/68	AD4 platinum repp./black 68 - 08		
	8/68 - 7/70	AF4 grey stripe 69/quick grey 69 - 13		
	8/68 - 7/70	AF5 brown stripe 69/nut brown 69 - 15		
	8/68 - 7/70	AF6 blue stripe 69/Capri blue 68 - 14		
	8/69 - 7/71	AH1 red stripe 70/gala red 69 - 01		
	8/70 - 7/71	AJ5 blue stripe 71/blue 71 - 26		
	8/70 - 7/71	AJ6 alabaster stripe 71/alabaster 71 - 27		
	8/70 - 7/71	AJ7 cork stripe 71/cork 71 - 28		
	8/71 -	AV2 black - 12		
	8/71 -	AV3 alabaster - 13		
	8/71 -	AV4 leather beige - 14		
	8/71 -	AV5 lapis blue - 15		
	8/71 -	AV6 bordeaux red - 19		
-	311 881 405 G	Cover - Front seat (leatherette) from Ch. No. 317 000 001	2	311-314,361-364; M 234
	8/66 - 7/67	697 platinum/platinum - 90		
	8/66 - 7/68	AD6 Indian red/Indian red 68 - 42, 91		
	3/67 - 7/67	667 Balearic beige/Balearic beige - 93		
	8/67 - 7/68	AD5 light sand 66/light sand 68 - 31		
	8/67 - 7/68	AD8 khaki brown/khaki brown 68 - 32		
	8/68 - 7/70	718 nut brown 69/nut brown 69 - 48		
	8/68 - 7/70	720 cream white 69/cream white 69 - 46		
	8/68 - 7/71	719 gala red 69/gala red 69 - 47		
	8/70 - 7/71	AK4 cork 71 - 53		
	8/66 - 7/71	AD7 black/black 68 - 40, 43, 50, 92		
	8/70 -	AK2 alabaster 71 - 52		
	8/71 -	AW8 leather beige - 55		
	8/71 -	AW9 lapis blue - 56		
	8/71	AX1 bordeaux red - 57		

-	315 881 405	Cover - Front seat (leatherette) from Ch. No. 221 975 to 315 220 883	2	315-318,365-368
	8/63 - 7/64	296 brown cord pattern/brown - 71		
	8/63 - 7/64	298 grey cord pattern/grey - 70		
	8/63 - 7/64	299 olive cord pattern/olive - 72		
	8/64 - 7/65	300 mesh grey/Oxford grey - 83		
	8/64 - 7/65	302 mesh green/pampas green - 86		
-	315 881 405 A	Cover - Front seat (cloth) from Ch. No. 315 000 001 to 315 220 883	2	315-318,365-368
	8/64 - 7/65	166 olive cord pattern/pampas green - 52		
	8/64 - 7/65	169 silver cord pattern/Oxford grey - 53		
-	315 881 405 B	Cover - Front seat (leatherette) from Ch. No. 316 000 001 to 317 157 344	2	315-318,365-368
	8/65 - 2/66	495 mesh grey/platinum		
	3/66 - 7/66	697 platinum/platinum - 74		
	3/66 - 7/66	AE2 black 66/black - 76		
	8/66 - 2/67	041 black/black - 88		
-	315 881 405 C	Cover - Front seat (leatherette) from Ch. No. 317 000 001	2	315-318,365-368; M 233; M 237: 311-318, 365-368
	8/66 - 7/68	AC3 dark platinum/platinum - 38,86		
	3/67 - 7/67	041 black/black - 88		
	8/68 - 7/70	AG2 dark platinum/platinum 69 - 50		
	8/69 - 7/70	718 nut brown 69/nut brown 69 - 48		
	8/69 - 7/70	720 cream white 69/cream white 69 - 46		
	8/69 - 7/71	719 gala red 69/gala red 69 - 47		
	8/70 - 7/71	AK4 cork 71 - 53		
	8/67 -	AD7 black/black 68 - 40, 50		
	8/70 -	AK2 alabaster 71 - 52		
	8/71 -	AW8 leather beige - 55		
	8/71 -	AW9 lapis blue - 56		
	8/71 -	AX1 bordeaux red - 57		
-	315 881 405 D	Cover - Front seat (cloth) from Ch. No. 316 000 001	2	315-318,365-368; M 233; M 237: 311-318, 365-368
	8/65 - 7/69	AF7 platinum grid/platinum 69 - 05,22,55		
	8/69 - 7/70	AG4 platinum pattern/platinum 69 - 19		
	8/69 - 7/70	AF2 red pattern 68/gala red 69 - 20		
	8/69 - 7/70	AF3 blue pattern 68/capri blue 68 - 21		
	8/70 - 7/71	AJ1 dogtooth blue 71/blue 71 - 16		
	8/70 - 7/71	AJ2 dogtooth grey 71/alabaster 71 - 17		
	8/70 - 7/71	AJ3 dogtooth red 71/gala red 69 - 18		
	8/70 - 7/71	AJ4 dogtooth cork 71/cork 71 - 22		
	8/70 - 7/71	AK7 dogtooth grey 71/black 68 - 68		
	8/71 -	AU6 black - 37		
	8/71 -	AU7 alabaster - 03		
	8/71 -	AU8 leather beige - 38		
	8/71 -	AU9 lapis blue - 05		
	8/71 -	AV1 bordeaux red - 10		

42	111 881 471	Cushion button from Ch. No. 221 975	4	315-318,365-368; M 233
43	111 881 475	Washer – Cushion button from Ch. No. 221 975	4	315-318,365-368; M 233
44	311 881 511 F	Frame – Front seat backrest to Ch. No. 317 180 000	2	
45	311 881 511 M	Frame – Front seat backrest from Ch. No. 317 180 001	2	
-	311 881 511 N	Frame – Front seat backrest with hd. restraint from Ch. No. 318 000 001 to 319 500 000	2	M 258
46	311 881 511 P	Frame – Front seat backrest with head restraint from Ch. No. 310 2000 001	2	M 258
47	311 881 569 A	Trim plate – Seat backrest, left from Ch. No. 316 000 001 to 319 500 000	1	311-314,361-364; M 234
-	311 881 570	Trim plate – Seat backrest, right from Ch. No. 316 000 001 to 318 500 000	1	311-314,361-364; M 234
-	311 881 570 A	Trim plate – Seat backrest, right from Ch. No. 319 000 001 to 319 500 000	1	311-314,361-364; M 234
48	311 881 589	Protective beading – Backrest frame from Ch. No. 317 180 001	4	
49	311 881 607	Escutcheon for arm – Backrest lock from Ch. No. 318 000 001 to 311 2500 000	2	
-	311 881 607 A	Escutcheon for arm for backrest lock from Ch. No. 312 2000 001	2	
50	311 881 633 A	Knob for arm – Backrest lock from Ch. No. 318 000 001 to 311 2500 000	2	
-	311 881 633 B	Knob for arm for backrest lock from Ch. No. 312 2000 001	2	
-	311 881 705	Spring core – Front seat backrest to Ch. No. 315 220 883	2	311,313,315,317, 361,363,365,367
			1	312,314,316,318, 362,364,366,368
51	311 881 705 D	Spring core – Front seat backrest from Ch. No. 317 000 001 to 317 180 000	2	311,313,315,317, 361,363,365,367
			1	312,314,316,318, 362,364,366,368
52	311 881 705 E	Spring core – Front seat backrest from Ch. No. 317 180 001	2	
-	311 881 705 F	Spring core – Backrest, front with head restraint from Ch. No. 318 000 001 to 319 500 000	2	M 258

53	311 881 705 G	Spring core – Front seat backrest with head restraint from Ch. No. 310 2000 001	2	M 258
–	312 881 706	Spring core – Front seat backrest, right to Ch. No. 315 220 883	1	312,314,316,318, 362,364,366,368
–	312 881 706 C	Spring core – Front seat backrest, right from Ch. No. 316 000 001 to 316 500 000	1	312,314,316,318, 362,364,366,368
–	312 881 706 D	Spring core – Front seat backrest, right from Ch. No. 317 000 001 to 317 180 000	1	312,314,316,318, 362,364,366,368
–	311 881 735	Head restraint from Ch. No. 318 000 001 to 319 500 000	2	M 258
54	113 881 735 A	Head restraint from Ch. No. 310 2000 001	2	M 258
–	311 881 775	Padding, front – Front seat backrest to Ch. No. 315 220 883	2	
55	311 881 775 A	Padding, front – Front seat backrest from Ch. No. 316 000 001 to 317 180 000	2 1	311,313,315,317, 361,363,365,367 312,314,316,318, 362,364,366,368
56	311 881 775 B	Padding, front – Front seat backrest from Ch. No. 317 180 001	2	
57	311 881 775 C	Padding, front – Front seat backrest with head restraint from Ch. No. 318 000 001	2	M 258
–	312 881 776	Padding, front, right – Front seat backrest from Ch. No. 316 000 001 to 317 180 000	1	312,314,316,318, 362,364,366,368
–	311 881 779	Padding, rear – Front seat backrest to Ch. No. 315 220 883	2	
–	311 881 805	Cover – Front seat backrest (cloth) to Ch. No. 221 974	2 1	311,313,361,363 312,314,362,364
	4/61 – 7/63	228 black-white/silver beige		
–	311 881 805 A	Cover – Front seat backrest (leatherette) from Ch. No. 221 975 to 483 592	2 1	311,313,361,363 312,314,362,364
	8/63 – 7/64	295 red cord pattern/oxide red – 73		
	8/63 – 7/64	296 brown cord pattern/brown – 71		
	8/63 – 7/64	299 olive cord pattern/olive – 72		

-	311 881 805 B	Cover - Front seat backrest (cloth)	2 1	311,313,361,363 312,314,362,364
	8/63 - 7/64	296 brown cord pattern/brown - 51		
	8/63 - 7/64	298 grey cord pattern/grey - 50		
	8/63 - 7/64	299 olive cord pattern/olive - 52		
-	311 881 805 C	Cover - Front seat backrest (cloth)	2 1	311,313,361,363 312,314,362,364
	8/64 - 7/65	166 olive cord pattern/pampas green - 52		
	8/64 - 7/65	169 silver cord pattern/Oxford grey - 53		
-	311 881 805 D	Cover - Front seat backrest (leatherette)	2 1	311,313,361,363 312,314,362,364
	8/64 - 7/65	300 mesh grey/Oxford grey - 83		
	8/64 - 7/65	301 mesh red/oxide red - 87		
	8/64 - 7/65	302 mesh green/pampas green - 86		
-	311 881 805 E	Cover - Front seat backrest (cloth)	2 1	311,313,361,363 312,314,362,364
	8/65 - 7/66	125 platinum repp./platinum - 50		
	8/65 - 7/66	126 Teak repp./Teak - 51		
	8/65 - 7/66	127 azure repp./azure - 54		
58	311 881 805 F	Cover - Front seat backrest (leatherette)	2 1	311,313,361,363 312,314,362,364
	8/65 - 7/66	041 black/black - 80		
	8/65 - 7/66	651 pigalle/pigalle - 79		
	8/65 - 7/66	667 Balearic beige/Balearic beige - 81		
	8/65 - 7/66	697 platinum/platinum - 78		
-	311 881 805 G	Cover - Front seat backrest (cloth)	2 1	311,313,361,363; M 234: 315,317 312,314,362,364; M 234: 316, 318
	8/66 - 5/67	AD1 khaki repp./khaki brown 68 - 52		
	8/66 - 5/67	125 platinum repp./platinum - 50		
	8/66 - 5/67	127 azure repp./azure - 54		
	8/66 - 5/67	126 Teak repp./Teak - 51		
-	311 881 805 H	Cover - Front seat backrest (leatherette)	2 1	311,313,361,363; M 234: 315,317 312,314,362,364; M 234: 316,318
	8/66 - 5/67	041 black/black - 92		
	8/66 - 5/67	667 Balearic beige/Balearic beige - 93		
	8/66 - 5/67	697 platinum/platinum - 90		
	8/66 - 5/67	752 Indian red/Indian red - 91		

-	311 881 805 K	Cover - Front seat backrest with head restraint (cloth)	2	M 258: 311-314,361-364
		from Ch. No. 318 000 001 to 319 500 000		
	8/67 - 7/68	125 platinum repp./platinum - 01		
	8/67 - 7/68	AD1 khaki repp./khaki brown 68 - 03		
	8/67 - 7/68	AD2 blue repp. 68/Capri blue 68 - 04		
	8/67 - 7/68	AD3 red repp. 68/Indian red 68 - 02		
	8/67 - 7/68	AD4 platinum repp./black 68 - 08		
	8/68 - 7/69	AF4 grey stripe 69/quick grey 69 - 13		
	8/68 - 7/69	AF5 brown stripe 69/nut brown 69 - 15		
	8/68 - 7/69	AF6 blue stripe 69/Capri blue 68 - 14		
-	311 881 805 L	Cover - Front seat backrest with head restraint (leatherette)	2	M 258: 311-314,361-364
		from Ch. No. 318 000 001 to 319 500 000		
	8/67 - 7/68	AD5 light sand 66/light sand 68 - 31		
	8/67 - 7/68	AD6 Indian red/Indian red 68 - 42		
	8/67 - 7/68	AD8 khaki brown/khaki brown 68 - 32		
	8/67 - 7/69	AD7 black/black 68 - 40,43		
	8/68 - 7/69	718 nut brown 69/nut brown 69 - 48		
	8/68 - 7/69	719 gala red 69/gala red 69 - 47		
	8/68 - 7/69	720 cream white 69/cream white 69 - 46		
59	311 881 805 M	Cover - Front seat backrest (cloth)	2	311-314,361-364; M 234
		from Ch. No. 317 180 001		
	5/67 - 7/67	AC5 khaki repp./khaki brown - 52		
	5/67 - 7/67	126 Teak repp./Teak - 51		
	5/67 - 7/67	127 azure repp./azure - 54		
	5/67 - 7/68	125 platinum/platinum - 01,50		
	8/67 - 7/68	AD1 khaki repp./khaki brown 68 - 03		
	8/67 - 7/68	AD2 blue repp.68/Capri blue 68 - 04		
	8/67 - 7/68	AD3 red repp. 68/Indian red 68 - 02		
	8/67 - 7/68	AD4 platinum repp./black 68 - 08		
	8/68 - 7/70	AF4 grey stripe 69/quick grey 69 - 13		
	8/68 - 7/70	AF5 brown stripe 69/nut brown 69 - 15		
	8/68 - 7/70	AF6 blue stripe 69/Capri blue 68 - 14		
	8/69 - 7/71	AH1 red stripe 70/gala red 69 - 01		
	8/70 - 7/71	AJ5 blue stripe 71/blue 71 - 26		
	8/70 - 7/71	AJ6 alabaster stripe 71/alabaster 71 - 27		
	8/70 - 7/71	AJ7 cork stripe 71/cork 71 - 28		
	8/71 -	AV2 black - 12		
	8/71 -	AV3 alabaster - 13		
	8/71 -	AV4 leather beige - 14		
	8/71 -	AV5 lapis blue - 15		
	8/71 -	AV6 bordeaux red - 19		
-	311 881 805 N	Cover - Front seat backrest (leatherette)	2	311-314,361-364; M 234
		from Ch. No. 317 180 001		
	5/67 - 7/67	667 Balearic beige/Balearic beige - 93		
	5/67 - 7/67	697 platinum/platinum - 90		



	5/67 - 7/67	752 Indian red/Indian red - 91		
	8/67 - 7/68	AD5 light sand 66/light sand 68 - 31		
	8/67 - 7/68	AD6 Indian red/Indian red 68 - 42		
	8/67 - 7/69	AD8 khaki brown/khaki brown 68 - 32		
	8/68 - 7/70	718 nut brown 69/nut brown 69 - 48		
	8/68 - 7/70	720 cream white 69/cream white 69 - 46		
	8/68 - 7/71	719 gala red 69/gala red 69 - 47		
	8/70 - 7/71	AK4 cork 71 - 53		
	5/67 -	AD7 black/black 68 - 40, 43, 50, 92		
	8/70 -	AK2 alabaster 71 - 52		
	8/71 -	AW8 leather beige - 55		
	8/71 -	AW9 lapis blue - 56		
	8/71 -	AX1 bordeaux red - 57		
60	311 881 805 Q	Cover - Front seat backrest with head restraint (cloth) from Ch. No. 310 2000 001 to 311 2500 000	2	M 258: 311-314, 361-364; M 234/M 258
	8/69 - 7/70	AF4 grey stripe 69/quick grey 69 - 13		
	8/69 - 7/70	AF5 brown stripe 69/nut brown 69 - 15		
	8/69 - 7/70	AF6 blue stripe 69/Capri blue 68 - 14		
	8/69 - 7/71	AH1 red stripe 70/gala red 69 - 01		
	8/70 - 7/71	AJ5 blue stripe 71/blue 71 - 26		
	8/70 - 7/71	AJ6 alabaster stripe 71/alabaster 71 - 27		
	8/70 - 7/71	AJ7 cork stripe 71/cork 71 - 28		
-	311 881 805 R	Cover - Front seat backrest with head restraint (leatherette) from Ch. No. 310 2000 001 to 311 2500 000	2	M 258: 311-314, 361-364 M 234/M 258
	8/69 - 7/70	718 nut brown 69/nut brown 69 - 48		
	8/69 - 7/70	720 cream white 69/cream white 69 - 46		
	8/69 - 7/71	719 gala red 69/gala red 69 - 47		
	8/70 - 7/71	AK4 cork 71 - 53		
	8/69 - 7/71	AD7 black/black 68 - 40		
	8/70 - 7/71	AK2 alabaster 71 - 52		
-	311 881 805 S	Cover - Front seat backrest with head restraint (cloth) from Ch. No. 312 2000 001	2	M 258: 311-314, 361-364; M 234/M 258
	8/71 -	AV2 black - 12		
	8/71 -	AV3 alabaster - 13		
	8/71 -	AV4 leather beige - 14		
	8/71 -	AV5 lapis blue - 15		
	8/71 -	AV6 bordeaux red - 19		
-	311 881 805 T	Cover - Front seat backrest with head restraint (leatherette) from Ch. No. 312 2000 001	2	M 258: 311-314, 361-364; M 234/M 258
	8/71 -	AW8 leather beige - 55		
	8/71 -	AW9 lapis blue - 56		
	8/71 -	AX1 bordeaux red - 57		
	8/71 -	AD7 black - 50		
	8/71 -	AK2 alabaster - 52		

-	315 881 805	Cover - Front seat backrest (leatherette)	2	315,317,365,367
		from Ch. No. 221 975 to 483 592	1	316,318,366,368
	8/63 - 7/64	296 brown cord pattern/brown - 71		
	8/63 - 7/64	298 grey cord pattern/grey - 70		
	8/63 - 7/64	299 olive cord pattern/olive - 72		
-	311 881 805 A	Cover - Front seat backrest (cloth)	2	315,317,365,367
		from Ch. No. 315 000 001 to 315 220 883	1	316,318,366,368
	8/64 - 7/65	166 olive cord pattern/pampas green - 52		
	8/64 - 7/65	169 silver cord pattern/Oxford grey - 53		
-	315 881 805 B	Cover - Front seat backrest (leatherette)	2	315,317,365,367
		from Ch. No. 315 000 001 to 315 220 883	1	316,318,366,368
	8/64 - 7/65	300 mesh grey/Oxford grey - 83		
	8/64 - 7/65	302 mesh green/pampas green - 86		
-	315 881 805 C	Cover - Front seat backrest (leatherette)	2	315,317,365,367
		from Ch. No. 316 000 001 to 317 180 000	1	316,318,366,368
	8/65 - 2/66	495 mesh grey/platinum		
	3/66 - 7/66	697 platinum/platinum - 74		
	3/66 - 7/66	AE2 black 66/black - 76		
	8/66 - 5/67	041 black/black - 88		
	8/66 - 5/67	AC3 dark platinum/platinum - 86		
-	315 881 805 D	Cover - Front seat backrest (leatherette)	2	315-318,365-368; M 233;
		from Ch. No. 317 180 001		M 237: 311-318,365-368
	5/67 - 7/68	AC3 dark platinum/platinum - 38,86		
	8/68 - 7/70	AG2 dark platinum/platinum 69 - 50		
	8/69 - 7/70	718 nut brown 69/nut brown 69 - 48		
	8/69 - 7/70	720 cream white 69/cream white 69 - 46		
	8/69 - 7/71	719 gala red 69/gala red 69 - 47		
	8/70 - 7/71	AK4 cork 71 - 53		
	5/67 -	AD7 black/black 68 - 40, 50, 88		
	8/70 -	AK2 alabaster 71 - 52		
	8/71 -	AW8 leather beige - 55		
	8/71 -	AW9 lapis blue - 56		
	8/71 -	AX1 bordeaux red - 57		
-	315 881 805 E	Cover - Front seat backrest with head restraint (cloth)		
		from Ch. No. 318 000 001 to 318 500 000	2	M 110
		from Ch. No. 319 000 001 to 319 500 000	2	M 258: 315-318,365-368
	8/67 - 7/68	131 platinum grid/platinum - 05		
	8/68 - 7/69	AF7 platinum grid/platinum 69 - 22		

-	315 881 805 F	Cover - Front seat backrest with head restraint (leatherette) from Ch. No. 318 000 001 to 318 500 000	2	M 110
	8/67 - 7/68	AC3 dark platinum/platinum - 38		
	8/67 - 7/68	AD7 black/black 68 - 40		
	8/68 - 7/69	AG2 dark platinum/platinum 69 - 50		
-	365 881 805	Cover - Front seat backrest (cloth) from Ch. No. 316 000 001 to 317 180 000	2 1	315,317,365,367 316,318,366,368
	8/65 - 5/67	131 platinum grid/platinum - 55		
-	365 881 805 B	Cover - Front seat backrest (cloth) from Ch. No. 317 180 001	2	315-318,365-368; M 233; M 237: 311-318, 365-368
	5/67 - 7/68	131 platinum grid/platinum - 05,55		
	8/68 - 7/69	AF7 platinum grid/platinum 69 - 22		
	8/69 - 7/70	AG4 platinum pattern/platinum 69 - 19		
	8/69 - 7/70	AF2 red pattern 68/gala red 69 - 20		
	8/69 - 7/70	AF3 blue pattern 68/Capri blue 68 - 21		
	8/70 - 7/71	AJ1 dogtooth blue 71/blue 71 - 16		
	8/70 - 7/71	AJ2 dogtooth grey 71/alabaster 71 - 17		
	8/70 - 7/71	AJ3 dogtooth red 71/gala red 69 - 18		
	8/70 - 7/71	AJ4 dogtooth cork 71/cork 71 - 22		
	8/70 - 7/71	AK7 dogtooth grey 71/black 68 - 08		
	8/71 -	AU6 black - 37		
	8/71 -	AU7 alabaster - 03		
	8/71 -	AU8 leather beige - 38		
	8/71 -	AU9 lapis blue - 05		
	8/71 -	AV1 bordeaux red - 10		
-	365 881 805 E	Cover - Front seat backrest with head restraint (cloth) from Ch. No. 310 2000 001 to 311 2500 000	2	M 258: 315-318,365-368; M 237/M258: 311-318; 365-368 M 233/M 258: 311-314
	8/69 - 7/70	AG4 platinum pattern/platinum 69 - 19		
	8/69 - 7/70	AF2 red pattern 68/gala red 69 - 20		
	8/69 - 7/70	AF3 blue pattern 68/Capri blue 68 - 21		
	8/70 - 7/71	AJ1 dogtooth blue 71/blue 71 - 16		
	8/70 - 7/71	AJ2 dogtooth grey 71/alabaster 71 - 17		
	8/70 - 7/71	AJ3 dogtooth red 71/gala red 69 - 18		
	8/70 - 7/71	AJ4 dogtooth cork 71/cork 71 - 22		
	8/70 - 7/71	AK7 dogtooth grey 71/black 68 - 08		

-	365 881 805 F	Cover - Front seat backrest with head restraint (leatherette) from Ch. No. 310 2000 001 to 311 2500 000	2	M 258: 315-318, 365-368; M237/M258:311-318, 365-368; M 233/M 258: 311-314
	8/69 - 7/70	AG2 dark platinum/platinum 69 - 50		
	8/69 - 7/70	718 nut brown 69/nut brown 69 - 48		
	8/69 - 7/70	720 cream white 69/cream white 69 - 46		
	8/69 - 7/71	719 gala red 69/gala red 69 - 47		
	8/70 - 7/71	AK4 cork 71 - 53		
	8/69 - 7/71	AD7 black/black 68 - 40		
	8/70 - 7/71	AK2 alabaster 71 - 52		
-	365 881 805 G	Cover - Front seat backrest with head restraint (cloth) from Ch. No. 312 2000 001	2	M 258: 315-318, 365-368; M 237/M 258:311-318, 365-368; M 233/M 258: 311-314
	8/71 -	AU6 black - 37		
	8/71 -	AU7 alabaster - 03		
	8/71 -	AU8 leather beige - 38		
	8/71 -	AU9 lapis blue - 05		
	8/71 -	AV1 bordeaux red - 10		
-	365 881 805 H	Cover - Front seat backrest with head restraint (leatherette) from Ch. No. 312 2000 001	2	M 258: 315-318, 365-368; M 237/M 258: 311-318, 365-368, M 233/M 258: 311-314
	8/71 -	AW8 leather beige - 55		
	8/71 -	AW9 lapis blue - 56		
	8/71 -	AX1 bordeaux red - 57		
	8/71 -	AD7 black - 50		
	8/71 -	AK2 alabaster - 52		
-	312 881 806	Cover - Front seat backrest, right (cloth) to Ch. No. 221 974	1	312, 314, 362, 364
	4/61 - 7/63	228 black-white/silver beige		
-	312 881 806 A	Cover - Front seat backrest, right (leatherette) from Ch. No. 221 975 to 483 592	1	312, 314, 362, 364
	8/63 - 7/64	295 red cord pattern/oxide red - 73		
	8/63 - 7/64	296 brown cord pattern/brown - 71		
	8/63 - 7/64	298 grey cord pattern/grey - 70		
	8/63 - 7/64	299 olive cord pattern/olive - 72		
-	312 881 806 B	Cover - Front seat backrest, right (cloth) from Ch. No. 221 975 to 483 592	1	312, 314, 362, 364
	8/63 - 7/64	296 brown cord pattern/brown - 51		
	8/63 - 7/64	298 grey cord pattern/grey - 50		
	8/63 - 7/64	299 olive cord pattern/olive - 52		
-	312 881 806 C	Cover - Front seat backrest, right (cloth) from Ch. No. 315 000 001 to 315 220 883	1	312, 314, 362, 364
	8/64 - 7/65	166 olive cord pattern/pampas green - 52		
	8/64 - 7/65	169 silver cord pattern/Oxford grey - 53		

-	312 881 806 D	Cover - Front seat backrest, right (leatherette) from Ch. No. 315 000 001 to 315 220 883	1	312,314,362,364
	8/64 - 7/65	300 mesh grey/Oxford grey - 83		
	8/64 - 7/65	301 mesh red/Oxford grey - 87		
	8/64 - 7/65	302 mesh green/pampas green - 86		
-	312 881 806 E	Cover - Front seat backrest, right (cloth) from Ch. No. 316 000 001 to 316 500 000	1	312,314,362,364
	8/65 - 7/66	125 platinum repp./platinum - 50		
	8/65 - 7/66	126 Teak repp./Teak - 51		
	8/65 - 7/66	127 azure repp./azure - 54		
-	312 881 806 F	Cover - Front seat backrest, right (leatherette) from Ch. No. 316 000 001 to 316 500 000	1	312,314,362,364
	8/65 - 7/66	041 black/black - 80		
	8/65 - 7/66	651 pigalle/pigalle - 79		
	8/65 - 7/66	667 Balearic beige/Balearic beige - 81		
	8/65 - 7/66	697 platinum/platinum - 78		
-	312 881 806 G	Cover - Front seat backrest, right (cloth) from Ch. No. 317 000 001 to 317 180 000	1	312,314,362,364; M 234:316,318
	8/66 - 5/67	AC5 khaki repp./khaki brown - 52		
	8/66 - 5/67	125 platinum repp./platinum - 50		
	8/66 - 5/67	126 Teak repp./Teak - 51		
	8/66 - 5/67	127 azure repp./azure - 54		
-	312 881 806 H	Cover - Front seat backrest, right (leatherette) from Ch. No. 317 000 001 to 317 180 000	1	312,314,362,364; M 234: 316,318
	8/66 - 5/67	041 black/black - 92		
	8/66 - 5/67	667 Balearic beige/Balearic beige - 93		
	8/66 - 5/67	697 platinum/platinum - 90		
	8/66 - 5/67	752 Indian red/Indian red - 91		
-	316 881 806	Cover - Front seat backrest, right (leatherette) from Ch. No. 221 975 to 483 592	1	316,318,366,368
	8/63 - 7/64	296 brown cord pattern/brown - 71		
	8/63 - 7/64	298 grey cord pattern/grey - 70		
	8/63 - 7/64	299 olive cord pattern/olive - 72		
-	316 881 806 A	Cover - Front seat backrest, right (cloth) from Ch. No. 315 000 001 to 315 220 883	1	316,318,366,368
	8/64 - 7/65	166 olive cord pattern/pampas green - 52		
	8/64 - 7/65	169 silver cord pattern/Oxford grey - 53		
-	316 881 806 B	Cover - Front seat backrest, right (leatherette) from Ch. No. 315 000 001 to 315 220 883	1	316,318,366,368
	8/64 - 7/65	300 mesh grey/Oxford grey - 83		
	8/64 - 7/65	302 mesh green/pampas green - 86		

-	316 881 806 C	Cover - Front seat backrest, right (leatherette) from Ch. No. 316 000 001 to 317 180 000	1	316,318,366,368
	8/65 - 2/66	495 mesh grey platinum		
	3 66 - 7 66	697 platinum/platinum - 74		
	3 66 - 7 66	AE2 black 66 black - 76		
	8 66 - 5 67	041 black/black - 88		
	8/66 - 5 67	AC3 dark platinum/platinum - 86		
-	366 881 806	Cover - Front seat backrest, right (cloth) from Ch. No. 316 000 001 to 317 180 000	1	316,318,366,368
	8 65 - 5/67	131 platinum grid/platinum - 55		
61	113 881 893	Cushion button from Ch. No. 318 000 001	8	M 258
	8 67 - 7/68	141 dark platinum - 01,08		
	8 67 - 7/68	149 dark khaki brown - 03,32		
	8 67 - 7/68	752 Indian red - 02,42		
	8 67 - 7 68	10X light sand 66 dark - 31		
	8/67 - 7/70	012 blue 68 - 04,14		
	8/68 - 7/70	717 quick grey 69 - 13		
	8 68 - 7/70	718 nut brown 69 - 15,48		
	8/68 - 7/70	720 cream white 69 - 46		
	8 68 - 7/71	719 gala red 69 - 01,47		
	8 70 - 7/71	50V blue 71 - 26		
	8 70 - 7/71	80V cork 71 - 28,53		
	8/67 -	041 black - 12,37,40,43,50		
	8 70 -	71V alabaster 71 - 03,13,17,27,52		
	8/71 -	31S bordeaux red 71 - 10,19,57		
	8/71 -	35S lapis blue 71 - 05,15,56		
	8 71 -	80W leather beige 71 - 14,38,55		
62	311 881 917 A	Door contact lever Backrest lock, left from Ch. No. 412 390 to 317 500 000	1	311-314,361-364; M 234
-	311 881 918	Door contact lever - Backrest lock, right to Ch. No. 412 389	1	311-314,361-364
-	311 881 918 A	Door contact lever - Backrest lock, right from Ch. No. 412 390 to 317 500 000	1	311-314,361-364; M 234
63	315 863 671	Plug - Door contact lever hole from Ch. No. 221 975 to 317 500 000	2	315-318,365-368
64	N 15 890 2	Tapping screw, fillister hd. A 4.9 x 13	2	315-318,365-368
65	N 11 523 3	Washer A 5,3	2	315-318,365-368
66	211 853 611 A	Packing from Ch. No. 221 975 to 317 500 000	2	315-318,365-368
67	311 881 919	Cable - Backrest lock to Ch. No. 317 500 000	2	311-314,361-364; M 234

68	311 881 925	Pull rod to Ch. No. 317 500 000	2	311-314,361-364; M 234
69	N 13 322 1	Pin 2.5 x 10 to Ch. No. 317 500 000	2	311-314,361-364; M 234
70	311 881 931	Spring - Pull rod to Ch. No. 317 500 000	2	311-314,361-364; M 234
-	311 881 939 A	Bush - Door contact lever to Ch. No. 317 500 000	X	311-314,361-364; M 234
71	311 881 945 A	Plug - Door contact lever to Ch. No. 317 500 000	2	311-314,361-364; M 234
72	311 881 947	Retainer for cable on seat to Ch. No. 317 500 000	2	311-314,361-364; M 234
73	311 881 965	Cap - Backrest lock operation to Ch. No. 412 389	2	311-314,361-364

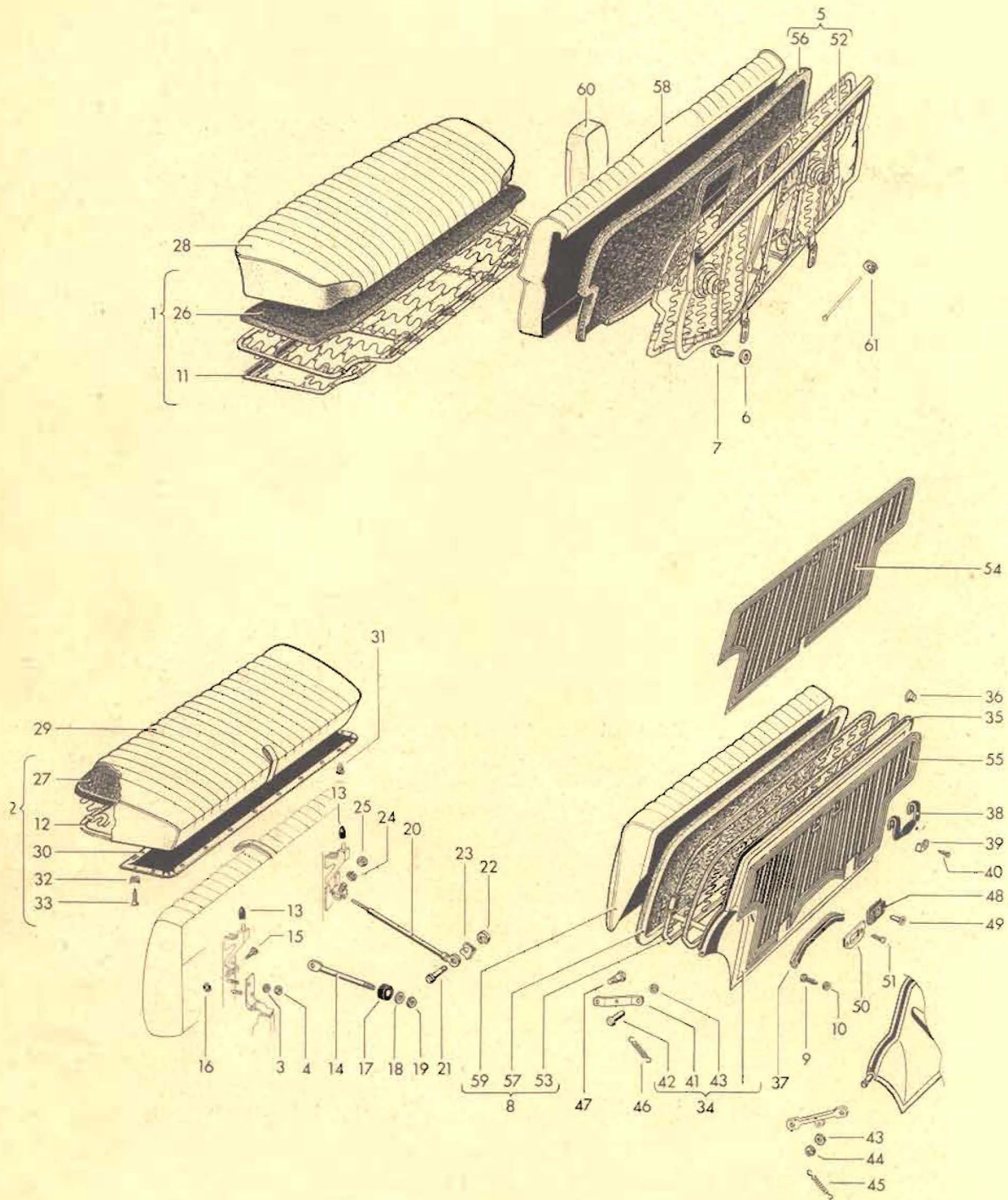



**MAIN GROUP 8**

**BODY**

Key	Part No.	Description	Qty.	Type and model
<b>REAR SEAT</b>				
-	331 885 031 B	Seat, rear (cloth) from Ch. No. 221 975 to 483 592	1	311-314
	8/63 - 7/64	299 olive cord pattern/olive - 52		
-	311 885 031 C	Seat, rear (leatherette) from Ch. No. 221 975 to 483 592	1	311-314
	8/63 - 7/64	299 olive cord pattern/olive - 72		
-	315 885 031	Seat, rear (leatherette) from Ch. No. 221 975 to 483 592	1	315-318
	8/63 - 7/64	296 brown cord pattern/brown - 71		
-	361 885 031 A	Seat, rear with trim panel (cloth) to Ch. No. 483 592	1	361-364
	8/63 - 7/64	299 olive cord pattern/olive - 52		
-	361 885 031 B	Seat, rear with trim panel (leatherette) from Ch. No. 221 975 to 483 592	1	361-364
	8/63 - 7/64	295 red cord pattern/oxide red - 73		
	8/63 - 7/64	299 olive cord pattern/olive - 72		
-	311 885 037	Seat, rear (with muslin covering) from Ch. No. 111 150 to 317 195 000	1	311-318; M 234
		from Ch. No. 317 195 001 to 317 500 000	1	315-318
-	311 885 037 A	Seat, rear (with muslin covering) from Ch. No. 317 195 001 to 317 500 000	1	311-314; M 234
1	311 885 037 B	Seat, rear (with muslin covering) from Ch. No. 318 000 001	1	311-318; M 233; M 234
-	361 885 037	Seat, rear (with muslin covering) from Ch. No. 111 150 to 367 180 000	1	361-368
		from Ch. No. 367 180 001 to 367 500 000	1	365-368
-	361 885 037 A	Seat, rear (with muslin covering) from Ch. No. 367 180 001 to 367 500 000	1	361-364
2	361 885 037 B	Seat, rear (with muslin covering) from Ch. No. 368 000 001 to 361 2500 000	1	361-368
-	361 885 037 C	Seat, rear (with muslin covering) from Ch. No. 362 2000 001	1	361-368
3	N 11 695 2	Washer 6.1	4	361-368
4	N 11 006 2	Nut, hex. M 6	4	361-368

-	311 885 039 B	Backrest, rear with arm rest (cloth) to Ch. No. 221 974 228 black-white/silver beige	1	311-314
	4/61 - 7/63			
-	311 885 039 C	Backrest, rear with arm rest (leatherette) from Ch. No. 221 975 to 483 592	1	311-314
	8/63 - 7/64	295 red cord pattern/oxide red - 73		
	8/63 - 7/64	298 grey cord pattern/grey - 70		
	8/63 - 7/64	299 olive cord pattern/olive - 72		
-	311 885 039 D	Backrest, rear with arm rest (cloth) from Ch. No. 221 975 to 483 592	1	311-314
	8/63 - 7/64	296 brown cord pattern/brown - 51		
	8/63 - 7/64	298 grey cord pattern/grey - 50		
	8/63 - 7/64	299 olive cord pattern/olive - 52		
-	311 885 041 D	Backrest, rear without arm rest (leatherette) from Ch. No. 221 975 to 483 592	1	M 260
	8/63 - 7/64	295 red cord pattern/oxide red - 73		
	8/63 - 7/64	296 brown cord pattern/brown - 71		
	8/63 - 7/64	298 grey cord pattern/grey - 70		
	8/63 - 7/64	299 olive cord pattern/olive - 72		
-	311 885 041 G	Backrest, rear without arm rest (cloth) from Ch. No. 221 975 to 483 592	1	M 260
	8/63 - 7/64	299 olive cord pattern/olive - 52		
-	315 885 041	Backrest, rear (leatherette) from Ch. No. 221 975 to 483 592	1	315-318
	8/63 - 7/64	296 brown cord pattern/brown - 71		
	8/63 - 7/64	298 grey cord pattern/grey - 70		
	8/63 - 7/64	299 olive cord pattern/olive - 72		
-	311 885 047	Backrest, rear with arm rest (with muslin covering) to Ch. No. 315 220 883	1	311-314
-	311 885 047 A	Backrest, rear without arm rest (with muslin covering) to Ch. No. 315 220 883	1	M 260
-	311 885 047 B	Backrest, rear with arm rest (with muslin covering) from Ch. No. 316 000 001 to 317 500 000	1	311-314; M 234
-	311 885 047 C	Backrest, rear without arm rest (with muslin covering) from Ch. No. 316 000 001 to 317 500 000	1	M 260
5	311 885 047 D	Backrest, rear with arm rest (with muslin covering) from Ch. No. 318 000 001 to 311 2500 000	1	311-314; M 234

-	311 885 047 E	Backrest, rear without arm rest (with muslin covering) from Ch. No. 318 000 001 to 311 2500 000	1	M 260
-	311 885 047 F	Backrest, rear with arm rest (with muslin covering) from Ch. No. 312 2000 001	1	311-314; M 234
-	311 885 047 G	Backrest, rear without arm rest (with muslin covering) from Ch. No. 312 2000 001	1	315-318; M 233; M 260
-	315 885 047	Backrest, rear without arm rest (with muslin covering) to Ch. No. 315 220 883	1	315-318
-	315 885 047 A	Backrest, rear without arm rest (with muslin covering) from Ch. No. 316 000 001 to 317 500 000	1	315-318
-	315 885 047 B	Backrest, rear without arm rest (with muslin covering) from Ch. No. 318 000 001 to 311 2500 000	1	315-318; M 233
-	N 11 654 2	Washer 9.5 to Ch. No. 317 500 000	1	311-318; M 234
-	N 10 237 5	Bolt, hex. hd. M 8 x 12 to Ch. No. 317 500 000	1	311-318; M 234
6	N 11 695 2	Washer 6.1 from Ch. No. 318 000 001	2	311-318; M 233; M 234
7	N 11 006 2	Bolt, hex. hd. M 6 from Ch. No. 318 000 001	2	311-318; M 233; M 234
-	361 885 051 A	Backrest, rear (leatherette) from Ch. No. 221 975 to 365 067 497	1	361-364
	8/63 - 7/64	296 brown cord pattern/brown - 71		
	8/63 - 7/64	299 olive cord pattern/olive - 72		
-	361 885 057	Backrest, rear (with muslin covering) to Ch. No. 365 220 883	1	361-368
-	361 885 057 A	Backrest, rear (with muslin covering) from Ch. No. 366 000 001 to 367 180 000 from Ch. No. 367 180 001 to 367 500 000	1 1	361-368 365-368
-	361 885 057 B	Backrest, rear (with muslin covering) from Ch. No. 367 180 001 to 367 500 000	1	361-364
8	361 885 057 C	Backrest, rear (with muslin covering) from Ch. No. 368 000 001 to 361 2500 000	1	361-368
-	361 885 057 D	Backrest, rear (with muslin covering) from Ch. No. 362 2000 001	1	361-368
-	N 13 890 2	Tapping screw, hex. hd. B 6.3x13 to Ch. No. 95 099	2	361-364

-	N 11 652 1	Washer 7 to Ch. No. 95 099	2	361-364
9	N 13 961 2	Tapping screw, countersunk head B 3.9x13 from Ch. No. 95 100	2	361-368
10	N 11 664 1	Washer 4.1 from Ch. No. 95 100	2	361-368
-	361 885 151	Hook for rear backrest lock from Ch. No. 362 2000 001	1	M 299
-	361 885 157	Spring - Rear backrest lock from Ch. No. 362 2000 001	1	M 299
-	361 885 159	Pin - Hook from Ch. No. 362 2000 001	1	M 299
-	N 12 885 1	Clamping plate 5 from Ch. No. 362 2000 001	1	M 299
-	311 885 305 A	Spring core - Rear seat to Ch. No. 111 149	1	311-314
-	311 885 305 B	Spring core - Rear seat from Ch. No. 111 150 to 317 195 000 from Ch. No. 317 195 001 to 317 500 000	1 1	311-318; M 234 315-318
-	311 885 305 C	Spring core - Rear seat from Ch. No. 317 195 001 to 317 500 000	1	311-314; M 234
11	311 885 305 E	Spring core - Rear seat from Ch. No. 318 000 001	1	311-318; M 233; M 234
-	361 885 305	Spring core - Rear seat to Ch. No. 111 149	1	361-364
-	361 885 305 A	Spring core - Rear seat from Ch. No. 111 150 to 367 180 000 from Ch. No. 367 180 001 to 367 500 000	1 1	361-368 365-368
-	361 885 305 B	Spring core - Rear seat from Ch. No. 367 180 001 to 367 500 000	1	361-364
12	361 885 305 D	Spring core - Rear seat from Ch. No. 368 000 001 to 361 2500 000	1	361-368
-	361 885 305 C	Spring core - Rear seat from Ch. No. 362 2000 001	1	
13	361 885 331	Cap - Retaining pin	2	361-368
14	361 885 341	Support - Rear seat to Ch. No. 111 149	2	361-364
15	111 837 257	Pin - Support to Ch. No. 111 149	2	361-364
16	N 12 455 1	Lock ring 5 to Ch. No. 111 149	2	361-364
17	111 837 261 B	Rubber buffer - Support to Ch. No. 111 149	2	361-364
18	311 827 181	Washer 8.3 - Support to Ch. No. 111 149	2	361-364
19	N 11 132 2	Nut, hex. M 8	4	361-364

20	361 885 343	Retaining cable – Rear seat from Ch. No. 111 150	2	361-368
21	311 837 257 A	Pin – Retaining cable from Ch. No. 111 150 to 365 067 497	2	361-368
22	N 12 435 1	Lock washer 5 from Ch. No. 111 150 to 365 067 497	2	361-368
23	311 721 519	Lock washer – Pin from Ch. No. 365 867 498	2	361-368
24	N 12 112 1	Lock washer J 12.5 from Ch. No. 111 150	2	361-368
25	N 11 010 4	Nut, hex. M 10 from Ch. No. 111 150	2	361-368
–	361 885 343 A	Retaining cable – Rear seat from Ch. No. 362 2000 001	2	M 299
–	N 10 239 0	Bolt, hex. hd. M 8 x 18 from Ch. No. 362 2000 001	2	M 299
–	111 857 799	Bolt, hex. hd. from Ch. No. 362 2000 001	2	M 299
–	N 11 531 2	Washer A 13 from Ch. No. 362 2000 001	2	M 299
–	N 13 968 1	Tapping screw fillister hd. B 4.8 x 13 from Ch. No. 362 2000 001	2	M 299
–	311 885 375	Padding – Rear seat to Ch. No. 317 195 000 from Ch. No. 317 195 001 to 317 500 000	1 1	311-318; M 234 315-318
26	311 885 375 A	Padding – Rear seat from Ch. No. 317 195 001 to 317 500 00 from Ch. No. 318 000 001	1 1	314-314; M 234 311-318; M 233; M 234
–	361 885 375	Padding – Rear seat to Ch. No. 367 180 000 from Ch. No. 367 180 001 to 367 500 000	1 1	361-368 365-368
–	361 885 375 B	Padding – Rear seat from Ch. No. 367 180 001 to 367 500 000	1	361-364
27	361 885 375 C	Padding – Rear seat from Ch. No. 368 000 001	1	361-368
–	311 885 405	Cover – Rear seat (cloth) to Ch. No. 221 974	1	311-314
–	4/61 – 7/63	228 black-white/silver beige		
–	311 885 405 A	Cover – Rear seat (leatherette) from Ch. No. 221 975 to 315 220 883	1	311-314
	8/63 – 7/64	295 red cord pattern/oxide red – 73		
	8/63 – 7/64	296 brown cord pattern/brown – 71		
	8/63 – 7/64	298 grey cord pattern/grey – 70		
	8/63 – 7/64	299 olive cord pattern – 72		
	8/64 – 7/65	300 mesh grey/Oxford grey – 83		
	8/64 – 7/65	301 mesh red/oxide red – 87		
	8/64 – 7/65	302 mesh green/pampas green – 86		

-	311 885 405 B	Cover - Rear seat (cloth) from Ch. No. 221 975 to 315 220 883	1	311-314
	8/63 - 7/64	298 grey cord pattern/grey - 50		
	8/63 - 7/64	296 brown cord pattern/brown - 51		
	8/63 - 7/64	299 olive cord pattern/olive - 52		
	8/64 - 7/65	166 olive cord pattern/pampas green - 52		
	8/64 - 7/65	169 silver cord pattern/Oxford grey - 53		
-	311 885 405 C	Cover - Rear seat (cloth) from Ch. No. 316 000 001 to 316 500 000	1	311-314
	8/65 - 7/66	125 platinum repp./platinum - 50		
	8/65 - 7/66	126 teak repp./teak - 51		
	8/65 - 7/66	127 azure repp./azure - 54		
-	311 885 405 D	Cover - Rear seat (leatherette) from Ch. No. 316 000 001 to 316 500 000	1	311-314
	8/65 - 7/66	041 black/black - 80		
	8/65 - 7/66	651 pigalle/pigalle - 79		
	8/65 - 7/66	667 Balearic beige/Balearic beige - 81		
	8/65 - 7/66	697 platinum/platinum - 78		
-	311 885 405 E	Cover - Rear seat (cloth) from Ch. No. 317 000 001 to 317 195 000	1	311-314; M 234
	8/66 - 4/67	AC 5 khaki repp./khaki brown - 52		
	8/66 - 4/67	125 platinum repp./platinum - 50		
	8/66 - 4/67	126 teak repp./teak - 51		
	8/66 - 4/67	127 azure repp./azure - 54		
-	311 885 405 F	Cover - Rear seat (leatherette) from Ch. No. 317 000 001 to 317 195 000	1	311-314; M 234
	8/66 - 4/67	041 black/black - 92		
	8/66 - 4/67	667 Balearic beige/Balearic beige - 93		
	8/66 - 4/67	697 platinum/platinum - 90		
	8/66 - 4/67	752 Indian red/Indian red - 91		
-	311 885 405 G	Cover - Rear seat (cloth) from Ch. No. 317 195 001 to 317 500 000	1	311-314; M 234
	5/67 - 7/67	AC 5 khaki repp./khaki brown - 52		
	5/67 - 7/67	125 platinum repp./platinum - 50		
	5/67 - 7/67	126 teak repp./teak - 51		
	5/67 - 7/67	127 azure repp./azure - 54		
-	311 885 405 J	Cover - Rear seat (leatherette) from Ch. No. 317 195 001 to 317 500 000	1	311-314; M 234
	5/67 - 7/67	041 black/black - 92		
	5/67 - 7/67	667 Balearic beige/Balearic beige - 93		
	5/67 - 7/67	697 platinum/platinum - 90		
	5/67 - 7/67	752 Indian red/Indian red - 91		
28	311 885 405 H	Cover - Rear seat (cloth) from Ch. No. 318 000 001	1	311-314; M 234
	8/67 - 7/68	125 platinum repp./platinum - 01		
	8/67 - 7/68	AD 1 khaki repp./khaki brown 68 - 03		
	8/67 - 7/68	AD 2 blue repp. 68/Capri blue 68 - 04		
	8/67 - 7/68	AD 3 red repp. 68/Indian red 68 - 02		

8/67 - 7/68	AD 4 platinum repp./black 68 - 08		
8/68 - 7/70	AF 4 grey stripe 69/quick grey 69 - 13		
8/68 - 7/70	AF 5 brown stripe 69/nut brown 69 - 15		
8/68 - 7/70	AF 6 blue stripe 69/Capri blue 68 - 14		
8/69 - 7/71	AH 1 red stripe 70/gala red 69 - 01		
8/70 - 7/71	AJ 5 blue stripe 71/blue 71 - 26		
8/70 - 7/71	AJ 6 alabaster stripe 71/alabaster 71 - 27		
8/70 - 7/71	AJ 7 cork stripe 71/cork 71 - 28		
8/71 -	AV2 black - 12		
8/71 -	AV3 alabaster - 13		
8/71 -	AV4 leather beige - 14		
8/71 -	AV5 lapis blue - 15		
8/71 -	AV6 bordeaux red - 19		
- 311 885 405 K	Cover - Rear seat (leatherette)	1	311-314; M 234
	from Ch. No. 318 000 001		
8/67 - 7/68	AD 5 light sand 66/light sand 68 - 31		
8/67 - 7/68	AD 6 Indian red/Indian red 68 - 42		
8/67 - 7/68	AD 8 khaki brown/khaki brown 68 - 32		
8/68 - 7/70	718 nut brown 69/nut brown 69 - 48		
8/68 - 7/70	720 cream white 69/cream white 69 - 46		
8/68 - 7/71	719 gala red 69/gala red 69 - 47		
8/70 - 7/71	AK 4 cork 71 - 53		
8/67 -	AD 7 black/black 68 - 40, 43, 50		
8/70 -	AK 2 alabaster 71 - 52		
8/71 -	AW8 leather beige - 55		
8/71 -	AW9 lapis blue - 56		
8/71 -	AX1 bordeaux red - 57		
- 315 885 405	Cover - Rear seat (leatherette)	1	315-318
	from Ch. No. 221 975 to 315 220 883		
8/63 - 7/64	296 brown cord pattern/brown - 71		
8/63 - 7/64	298 grey cord pattern/grey - 70		
8/63 - 7/64	299 olive cord pattern/olive - 72		
8/64 - 7/65	300 mesh grey/Oxford grey - 83		
8/64 - 7/65	302 mesh green/pampas green - 86		
- 315 885 405 A	Cover - Rear seat (cloth)	1	315-318
	from Ch. No. 315 000 001 to 315 220 883		
8/64 - 7/65	166 silver cord pattern/Oxford grey - 52		
8/64 - 7/65	169 olive cord pattern/pampas green - 53		
- 315 885 405 C	Cover - Rear seat (leatherette)	1	315-318; M 233;
	from Ch. No. 316 000 001		M 237:311-318
8/65 - 2/66	495 mesh grey/platinum		
3/66 - 7/66	697 platinum/platinum - 74		
3/66 - 7/66	AE 2 black 66/black - 76		
8/66 - 7/68	AC 3 dark platinum/platinum - 38, 86		
8/68 - 7/70	AG 2 dark platinum/platinum 69 - 50		
8/69 - 7/70	718 nut brown 69/nut brown 69 - 48		
8/69 - 7/70	720 cream white 69/cream white 69 - 46		
8/69 - 7/71	719 gala red 69/gala red 69 - 47		

8/70 - 7/71	AK 4 cork 71 - 53		
8/66 -	AD7 black/black 68 - 40, 50, 88		
8/70 -	AK 2 alabaster 71 - 52		
8/71 -	AW8 leather beige - 55		
8/71 -	AW9 lapis blue - 56		
8/71 -	AX1 bordeaux red - 57		
- 315 885 405 E	Cover - Rear seat (cloth) from Ch. No. 316 000 001	1	315-318; M 233; M 237: 311-318
8/65 - 7/69	AF 7 platinum grid/platinum 69 - 05, 22, 55		
8/69 - 7/70	AG 4 platinum pattern/platinum 69 - 19		
8/69 - 7/70	AF2 red pattern 68/gala red 69 - 20		
8/69 - 7/70	AF3 blue pattern 68/Capri blue 68 - 21		
8/70 - 7/71	AJ1 dogtooth blue 71/blue 71 - 16		
8/70 - 7/71	AJ2 dogtooth grey 71/alabaster 71 - 17		
8/70 - 7/71	AJ3 dogtooth red 71/gala red 69 - 18		
8/70 - 7/71	AJ4 dogtooth cork 71/cork 71 - 22		
8/70 - 7/71	AK7 dogtooth grey 71/black 68 - 08		
8/71 -	AU6 black - 37		
8/71 -	AU7 alabaster - 03		
8/71 -	AU8 leather beige - 38		
8/71 -	AU9 lapis blue - 05		
8/71 -	AV1 bordeaux red - 10		
- 361 885 405	Cover - Rear seat (cloth) to Ch. No. 221 974	1	361-364
4/61 - 7/63	228 black-white/silver beige		
- 361 885 405 A	Cover - Rear seat (leatherette) from Ch. No. 221 975 to 365 220 883	1	361-364
8/63 - 7/64	295 red cord pattern/oxide red - 73		
8/63 - 7/64	296 brown cord pattern/brown - 71		
8/63 - 7/64	298 grey cord pattern/grey - 70		
8/63 - 7/64	299 olive cord pattern/olive - 72		
8/64 - 7/65	300 mesh grey/Oxford grey - 83		
8/64 - 7/65	301 mesh red/oxide red - 87		
8/64 - 7/65	302 mesh green/pampas green - 86		
- 361 885 405 B	Cover - Rear seat (cloth) from Ch. No. 221 975 to 365 220 883	1	361-364
8/63 - 7/64	296 brown cord pattern/brown - 51		
8/63 - 7/64	298 grey cord pattern/grey - 50		
8/63 - 7/64	299 olive cord pattern/olive - 52		
8/64 - 7/65	166 olive cord pattern/pampas green - 52		
8/64 - 7/65	169 silver cord pattern/Oxford grey - 53		
- 361 885 405 C	Cover - Rear seat (cloth) from Ch. No. 366 000 001 to 366 500 000	1	361-364
8/65 - 7/66	125 platinum repp./platinum - 50		
8/65 - 7/66	126 teak repp/teak - 51		
8/65 - 7/66	127 azure repp./azure - 54		



-	361 885 405 D	Cover - Rear seat (leatherette)	1	361-364
		from Ch. No. 366 000 001 to 366 500 000		
	8/65 - 7/66	041 black/black - 80		
	8/65 - 7/66	651 pigalle/pigalle - 79		
	8/65 - 7/66	667 Balearic beige/Balearic beige - 81		
	8/65 - 7/66	697 platinum/platinum - 78		
-	361 885 405 F	Cover - Rear seat (cloth)	1	361-364
		from Ch. No. 367 000 001 to 367 180 000		
	8/66 - 2/67	AC 5 khaki repp./khaki brown - 52		
	8/66 - 2/67	125 platinum repp./platinum - 50		
	8/66 - 2/67	126 teak repp./teak - 51		
	8/66 - 2/67	127 azure repp./azure - 54		
-	361 885 405 G	Cover - Rear seat (leatherette)	1	361-364
		from Ch. No. 367 000 001 to 367 180 000		
	8/66 - 2/67	041 black/black - 92		
	8/66 - 2/67	667 Balearic beige/Balearic beige - 93		
	8/66 - 2/67	697 platinum/platinum - 90		
	8/66 - 2/67	752 Indian red/Indian red - 91		
-	361 885 405 H	Cover - Rear seat (cloth)	1	361-364
		from Ch. No. 367 180 001 to 367 500 000		
	3/67 - 7/67	AC 5 khaki repp./khaki brown - 52		
	3/67 - 7/67	125 platinum repp./platinum - 50		
	3/67 - 7/67	126 teak repp./teak - 51		
	3/67 - 7/67	127 azure repp./azure - 54		
-	361 885 405 J	Cover - Rear seat (leatherette)	1	361-364
		from Ch. No. 367 180 001 to 367 500 000		
	3/67 - 7/67	041 black/black - 92		
	3/67 - 7/67	667 Balearic beige/Balearic beige - 93		
	3/67 - 7/67	697 platinum/platinum - 90		
	3/97 - 7/67	752 Indian red/Indian red - 91		
29	361 885 405 K	Cover - Rear seat (cloth)	1	361-364
		from Ch. No. 368 000 001 to 361 2500 000		
	8/67 - 7/68	125 platinum repp./platinum - 01		
	8/67 - 7/68	AD 1 khaki repp./khaki brown 68 - 03		
	8/67 - 7/68	AD 2 blue repp. 68/Capri blue 68 - 04		
	8/67 - 7/68	AD 3 red repp. 68/Indian red 68 - 02		
	8/67 - 7/68	AD 4 platinum repp./black 68 - 08		
	8/68 - 7/70	AF 4 grey stripe 69/quick grey 69 - 13		
	8/68 - 7/70	AF 5 brown stripe 69/nut brown 69 - 15		
	8/68 - 7/70	AF 6 blue stripe 69/Capri blue 68 - 14		
	8/69 - 7/71	AH 1 red stripe 70/gala red 69 - 01		
	8/70 - 7/71	AJ 5 blue stripe 71/blue 71 - 26		
	8/70 - 7/71	AJ 6 alabaster stripe 71/alabaster 71 - 27		
	8/70 - 7/71	AJ 7 cork stripe 71/cork 71 - 28		
-	361 885 405 L	Cover - Rear seat (leatherette)	1	361-364
		from Ch. No. 368 000 001 to 361 2500 000		
	8/67 - 7/68	AD 5 light sand 66/light sand 68 - 31		
	8/67 - 7/68	AD 6 Indian red/Indian red 68 - 42		

8/67 - 7/68	AD 8 khaki brown/khaki brown 68 - 32		
8/68 - 7/70	718 nut brown 69/nut brown 69 - 48		
8/68 - 7/70	720 cream white 69/cream white 69 - 46		
8/68 - 7/71	719 gala red 69/gala red 69 - 47		
8/70 - 7/71	AK 4 cork 71 - 53		
8/67 - 7/71	AD 7 black/black 68 - 40, 43		
8/70 - 7/71	AK 2 alabaster 71 - 52		
- 361 885 405 M	Cover - Rear seat (cloth)	1	361-364
	from Ch. No. 362 2000 001		
8/71 -	AV2 black - 12		
8/71 -	AV3 alabaster - 13		
8/71 -	AV4 leather beige - 14		
8/71 -	AV5 lapis blue - 15		
8/71 -	AV6 bordeaux red - 19		
- 361 885 405 N	Cover - Rear seat (leatherette)	1	361-364
	from Ch. No. 362 2000 001		
8/71 -	AW8 leather beige - 55		
8/71 -	AW9 lapis blue - 56		
8/71 -	AX1 bordeaux red - 57		
8/71 -	AK7 black - 50		
8/71 -	AK2 alabaster - 52		
- 365 885 405	Cover - Rear seat (leatherette)	1	365-368
	from Ch. No. 221 975 to 365 220 883		
8/63 - 7/64	296 brown cord pattern/brown - 71		
8/63 - 7/64	298 grey cord pattern/grey - 70		
8/63 - 7/64	299 olive cord pattern/olive - 72		
8/64 - 7/65	300 mesh grey/Oxford grey - 83		
8/64 - 7/65	302 mesh green/pampas green - 86		
- 365 885 405 A	Cover - Rear seat (cloth)	1	365-368
	from Ch. No. 365 000 001 to 365 220 883		
8/64 - 7/65	166 olive cord pattern/pampas green - 52		
8/64 - 7/65	169 silver cord pattern/Oxford grey - 53		
- 365 885 405 C	Cover - Rear seat (leatherette)	1	365-368
	from Ch. No. 366 000 001 to 367 500 000		
8/65 - 2/66	495 mesh grey/platinum		
3/66 - 7/66	697 platinum/platinum - 74		
3/66 - 7/66	AE 2 black 66/black - 76		
8/66 - 7/67	041 black/black - 88		
8/66 - 7/67	AC 3 dark platinum/platinum - 86		

-	365 885 405 G	Cover - Rear seat (cloth)	1	365-368; M 237: 365-368
		from Ch. No. 366 000 001 to 361 2500 000		
	8/65 - 7/69	AF 7 platinum grid/platinum 69 - 22, 55		
	8/67 - 7/68	131 platinum grid/platinum - 05		
	8/69 - 7/70	AG 4 platinum pattern/platinum 69 - 19		
	8/69 - 7/70	AF2 red pattern 68/gala red 69 - 20		
	8/69 - 7/70	AF3 blue pattern 68/Capri blue 68 - 21		
	8/70 - 7/71	AJ1 dogtooth blue 71/blue 71 - 16		
	8/70 - 7/71	AJ2 dogtooth grey 71/alabaster 71 - 17		
	8/70 - 7/71	AJ3 dogtooth red 71/gala red 69 - 18		
	8/70 - 7/71	AJ4 dogtooth cork 71/cork 71 - 22		
	8/70 - 7/71	AK7 dogtooth grey 71/black 68 - 08		
-	365 885 405 H	Cover - Rear seat (leatherette)	1	365-368; M 237: 365-368
		from Ch. No. 368 000 001 to 361 2500 000		
	8/67 - 7/68	AC 3 dark platinum/platinum - 38		
	8/68 - 7/70	AG 2 dark platinum/platinum 69 - 50		
	8/69 - 7/70	718 nut brown 69/nut brown 69 - 48		
	8/69 - 7/70	720 cream white 69/cream white 69 - 46		
	8/69 - 7/71	719 gala red 69/gala red 69 - 47		
	8/70 - 7/71	AK4 cork 71 - 53		
	8/67 - 7/71	AD 7 black/black 68 - 40		
	8/70 - 7/71	AK2 alabaster 71 - 52		
-	365 885 405 M	Cover - Rear seat (cloth)	1	365-368; M 237: 365-368
		from Ch. No. 362 2000 001		
	8/71 -	AU6 black - 37		
	8/71 -	AU7 alabaster - 03		
	8/71 -	AU8 leather beige - 38		
	8/71 -	AU9 lapis blue - 05		
	8/71 -	AV1 bordeaux red - 10		
-	365 885 405 N	Cover - Rear seat (leatherette)	1	365-368; M 237: 365-368
		from Ch. No. 362 2000 001		
	8/71 -	AW8 leather beige - 55		
	8/71 -	AW9 lapis blue - 56		
	8/71 -	AX1 bordeaux red - 57		
	8/71 -	AD7 black - 50		
	8/71 -	AK2 alabaster - 52		
30	361 885 441	Trim panel, lower - Rear seat	1	
	4/61 - 7/65	469 anthracite		361-368
	8/65 - 7/66	192 lava 68 - 55, 74, 76, 80, 83		361-368
	8/65 - 7/66	652 scarlet - 79		361-368
	8/65 - 7/67	634 ultra blue - 54		361-368
	8/65 - 7/67	662 almond beige - 81		361-368
	8/65 - 7/67	672 rust - 51		361-368
	8/65 - 7/66	469 anthracite - 50		361-368
	8/66 - 7/67	192 lava 68 - 50, 55, 86, 88, 90, 91, 92		361-368
	8/66 - 7/67	772 dark brown - 52		361-368
	8/67 - 12/67	072 light beige 68 - 31		361-368
	8/67 - 12/67	192 lava 68 - 01, 02, 05, 08, 38, 40, 42, 43		361-368

8/67 - 7/70	045	Capri blue 68 - 04, 14		361-368
8/67 - 7/70	193	dark brown 68 - 03, 15, 32, 48		361-368
1/68 - 7/70	192	lava 68 - 01, 02, 05, 08, 13, 31, 38, 40, 42, 43, 46, 47		361-368
8/70 - 7/71	50V	blue 71 - 26		361-368
8/70 - 7/71	71V	alabaster 71 - 27, 52		361-368
8/70 - 7/71	80V	cork 71 - 28, 53		361-368
8/70 - 7/71	172	black 68 - 40		361-368
8/70 - 7/71	192	lava 68 - 08, 16, 17, 18, 22, 40, 47, 52, 53		361-368; M 237: 365-368
8/70 - 7/71	719	gala red 69 - 01, 47		361-368
8/71 -	355	bordeaux red 72 - 19, 57		361-364
8/71 -	595	lapis blue 72 - 15, 56		361-364
8/71 -	815	leather beige 72 - 14, 55		361-364
8/71 -	71V	alabaster 71 - 13, 52		361-364
8/71 -	172	black 68 - 12, 50		361-364
8/71 -	192	lava 68 - 03, 05, 10, 37, 38, 50, 52, 55, 56, 57		365-368; M 237: 365-368
31	361 885 449 A	Clip, to Ch. No. 44 000	12	361-364
32	N 11 701 1	Cone washer A 4.4	12	361-368
33	N 14 094 2	Tapping screw, csk. hd. B 4.2x16	12	361-368
-	361 885 461 B	Loop - Rear seat from Ch. No. 362 2000 001	1	M 299
34	361 885 501 A	Rear panel with pivot rods for rear backrest from Ch. No. 368 000 001 to 311 2500 000	1	361-368
-	361 885 501 B	Rear panel with pivot rods for rear backrest from Ch. No. 312 2000 001	1	361-368
-	361 885 533 D	Beading upper - Rear panel from Ch. No. 362 2000 001	1	M 299
35	361 885 533 C	Beading upper - Rear panel	1	361-368
	8/65 - 7/66	651 pigalle - 79		
	8/65 - 7/67	637 azure - 54		
	8/65 - 7/67	667 Balearic beige - 81, 93		
	8/65 - 7/67	671 teak - 51		
	4/61 -	043 grey-black		
36	361 885 537	Eye - Retaining pin	2	361-368
37	361 885 545	Beading lower for rear panel from Ch. No. 318 000 001	1	361-368
	8/67 -	043 grey-black		
38	361 885 549	Handle - Rear panel	1	361-368
39	111 885 589	Plate - Handle	2	362-368
40	N 11 466 3	Tapping screw, csk. hd. B 3.9 x 13	2	361-368
41	361 885 573 A	Pivot rod - Rear seat backrest	2	361-368
-	N 13 277 1	Pin 10x30 - Rear panel from Ch. No. 366 300 000 to 367 500 000	2	361-368
42	N 13 275 1	Pin 10 x 42 - Rear panel from Ch. No. 368 000 001	2	361-368

43	111 955 245	Washer 10.3x16	2	361-368
44	N 12 437 1	Lock washer 7 to Ch. No. 366 299 999	2	361-368
45	361 885 579	Spring – Backrest, rear to Ch. No. 366 500 000	2	361-368
46	361 885 579 A	Spring – Backrest, rear from Ch. No. 367 000 001	2	361-368
47	361 885 591 A	Bolt hex. hd. M 8x19	2	361-368
48	361 885 581	Guide piece from Ch. No. 366 000 001	2	361-368
49	N 13 792 3	Rivet 4x0.4x7 from Ch. No. 366 000 001	2	361-368
-	361 885 593	Cover plate for rear seat backrest retaining hook to Ch. No. 367 500 000	1	361-368
50	361 885 593 A	Cover plate for rear seat backrest retaining hook from Ch. No. 368 000 001	2	361-368
51	N 11 466 3	Tapping screw, csk. hd. B 3.9x13	4	361-368
-	361 885 621	Retaining plate, left for backrest lock, rear from Ch. No. 362 2000 001	1	M 299
-	361 885 622	Retaining plate, right for backrest lock, rear from Ch. No. 362 2000 001	1	M 299
-	N 21 503 1	Tapping screw, csk. raised hd. M 5 x 12	10	M 299
-	361 885 637	Spring for release lever from Ch. No. 362 2000 001	1	M 299
-	N 13 324 1	Pin 2.5 x 18	2	M 299
-	361 885 639	Cap for beading, upper from Ch. No. 362 2000 001	2	M 299
-	181 867 369	Cap for beading, lower from Ch. No. 362 2000 001	2	M 299
-	361 885 649	Release lever for backrest lock from Ch. No. 362 2000 001	1	M 299
-	311 711 741	Knob for lever 043 grey black from Ch. No. 362 2000 001	1	M 299
-	211 817 851	Spring washer from Ch. No. 362 2000 001	2	M 299
-	361 885 651	Locking hook, left for rear seat backrest from Ch. No. 362 2000 001	1	M 299

-	361 885 652	Locking hook, right for rear seat backrest from Ch. No. 362 2000 001	1	M 299
-	N 12 438 1	Spring washer 9	2	M 299
-	361 885 657	Spring for locking hook, left from Ch. No. 362 2000 001	1	M 299
-	361 885 658	Spring for locking hook, right from Ch. No. 362 2000 001	1	M 299
-	361 885 661	Tapping screw for cap from Ch. No. 362 2000 001	2	M 299
-	N 11 522 2	Washer A 4.3	2	M 299
-	411 881 319	Cap from Ch. No. 362 2000 001	2	M 299
-	361 885 665	Spacer sleeve for locking hook from Ch. No. 362 2000 001	2	M 299
-	361 885 669	Cap for locking hook, left from Ch. No. 362 2000 001	1	M 299
-	361 885 670	Cap for locking hook, right from Ch. No. 362 2000 001	1	M 299
-	311 885 705	Spring core for rear seat backrest without arm rest to Ch. No. 315 220 883	1	M 260
-	311 885 705 C	Spring core for rear seat backrest with arm rest to Ch. No. 315 220 883	1	311-314
-	311 885 705 D	Spring core for rear seat backrest without arm rest from Ch. No. 316 000 001 to 317 195 000	1	M 260; M 260/M 234
-	311 885 705 G	Spring core for rear seat backrest without arm rest from Ch. No. 317 195 001 to 317 500 000	1	M 260; M 260/M 234
52	311 885 705 H	Spring core for rear seat backrest with arm rest from Ch. No. 316 000 001 to 311 2500 000 use : from Ch. No. 316 000 001 to 317 195 000 311 885 775 F	1	311-314; M 234
-	311 885 705 J	Spring core for rear seat backrest without arm rest from Ch. No. 318 000 001 to 311 2500 000	1	M 260; M 260/M 234
-	311 885 705 L	Spring core for rear seat backrest with arm rest from Ch. No. 312 2000 001	1	311-314; M 234

-	315 885 705	Spring core - Rear seat backrest from Ch. No. 221 975 to 317 500 000	1	315-318
-	315 885 705 B	Spring core - Rear seat backrest from Ch. No. 312 2000 001	1	315-318; M 233, M 260,
		from Ch. No. 318 000 001 to 311 2500 000	1	315-318; M 233 M 260/M234
-	361 885 705	Spring core - Rear seat backrest to Ch. No. 367 180 000	1	361-368
		from Ch. No. 367 180 001 to 367 500 000	1	365-368
-	361 885 705 B	Spring core - Rear seat backrest from Ch. No. 367 180 001 to 367 500 000	1	361-364
53	361 885 705 C	Spring core - Rear seat backrest from Ch. No. 368 000 001 to 361 2500 000	1	361-368
-	361 885 705 D	Spring core - Rear seat backrest from Ch. No. 362 2000 001	1	361-368
54	361 885 753	Rubber lining for rear panel to Ch. No. 367 500 000	1	
	4 61 - 7 63	426 graphite		361-364
	4 61 - 7 65	469 anthracite		361-368
	8 65 - 7 66	652 scarlet - 79		361-364
	8 65 - 7 67	046 lava - 50, 78, 80, 90, 91, 92		361-364
	8 65 - 7 67	634 ultra blue - 54		361-364
	8 65 - 7 67	662 almond beige - 81, 93		361-364
	8 65 - 7 67	672 rust - 51		361-364
	8 66 - 7 67	772 dark brown - 52		361-364
55	361 885 753 B	Rubber lining for rear panel from Ch. No. 368 000 001 to 361 2500 000	1	361-364
	8 67 - 12 67	046 lava - 01, 02, 08, 42, 43		
	8 67 - 12 67	072 light beige 68 - 31		
	8 67 - 7 70	634 ultra blue - 04, 14		
	8 67 - 7 70	772 dark brown - 03, 15, 32, 48		
	1 68 - 7 70	046 lava - 01, 02, 08, 13, 31, 40, 42, 43, 46, 47		
	8 70 - 7 71	50V blue 71 - 26		
	8 70 - 7 71	80V cork 71 - 28, 53		
	8 70 - 7 71	727 grey 69 - 01, 27, 40, 47, 52		
-	361 885 753 F	Rubber lining for rear panel from Ch. No. 362 2000 001	1	361-364
	8 71 -	59S lapis blue 72 - 15, 56		
	8 71 -	81S leather beige 72 - 14, 55		
	8 71 -	727 grey 69 - 12, 13, 19, 50, 52, 57		
-	365 885 753 A	Rubber lining for rear panel from Ch. No. 366 000 001 to 367 500 000	1	365-368
	8 65 - 7 67	041 black		

-	365 885 753 C	Rubber lining for rear panel from Ch. No. 368 000 001 041 black	1	365-368
	8 67 -			
-	311 885 775	Padding for rear seat backrest without arm rest to Ch. No. 315 220 883	1	M 260
-	311 885 775 C	Padding for rear seat backrest with arm rest to Ch. No. 315 220 883	1	311-314
-	311 885 775 E	Padding for rear seat backrest without arm rest from Ch. No. 316 000 001 to 317 195 000	1	M 260; M 260/M 234
56	311 885 775 F	Padding for rear seat backrest with arm rest from Ch. No. 316 000 001 to 311 2500 000 use from Ch. No. 316 000 001 to 317 195 000 311 885 705 H	1	311-314; M 234
-	311 885 775 G	Padding for rear seat backrest without arm rest from Ch. No. 317 195 001 to 311 2500 000	1	M 260; M 260 M 234
-	311 885 775 H	Padding for rear seat backrest with arm rest from Ch. No. 312 2000 001	1	311-314; M 234
-	311 885 775 J	Padding for rear seat backrest without arm rest from Ch. No. 312 2000 001	1	315-318; M 233; M 260; M260/M 234
-	315 885 775	Padding - Rear seat backrest from Ch. No. 221 975 to 315 220 883	1	315-318
-	315 885 775 A	Padding - Rear seat backrest from Ch. No. 316 000 001 to 311 2500 000	1	315-318; M 233
-	361 885 775	Padding - Rear seat backrest to Ch. No. 365 220 883	1	361-368
-	361 885 775 A	Padding - Rear seat backrest from Ch. No. 366 000 001 to 367 180 000 from Ch. No. 367 180 001 to 367 500 000	1 1	361-368 365-368
57	361 885 775 B	Padding - Rear seat backrest from Ch. No. 367 180 001 to 367 500 000 from Ch. No. 368 000 001	1 1	361-364 361-368
-	311 885 805	Cover - Rear seat backrest without arm rest (cloth) to Ch. No. 221 974 228 black-white/silver beige	1	M 620
	4 61 - 7 63			
-	311 885 805 C	Cover - Rear seat backrest with arm rest (cloth) to Ch. No. 221 974 228 black-white/silver beige	1	311-314
	4 61 - 7 63			



-	311 885 805 D	Cover - Rear seat backrest with arm rest (leatherette) from Ch. No. 221 975 to 315 229 883	1	311-314
	8 63 - 7 64	295 black cord pattern/oxide red - 73		
	8 63 - 7 64	296 brown cord pattern/brown - 71		
	8 63 - 7 64	298 grey cord pattern/grey - 70		
	8 63 - 7 64	299 olive cord pattern/olive - 72		
	8 64 - 7 65	300 mesh grey/Oxford grey - 83		
	8 64 - 7 65	301 mesh red/oxide red - 87		
	8 64 - 7 65	302 mesh green/pampas green - 86		
-	311 885 805 E	Cover - Rear seat backrest without arm rest (leatherette) from Ch. No. 221 975 to 315 220 883	1	M 260
	8 63 - 7 64	295 red cord pattern/oxide red - 73		
	8 63 - 7 64	296 brown cord pattern/brown - 71		
	8 63 - 7 64	298 grey cord pattern/grey - 70		
	8 63 - 7 64	299 olive cord pattern/olive - 72		
	8 64 - 7 65	300 mesh grey/Oxford grey - 83		
	8 64 - 7 65	301 mesh red/oxide red - 87		
	8 64 - 7 65	302 mesh green/pampas green - 86		
-	311 885 805 F	Cover - Rear seat backrest with arm rest (cloth) from Ch. No. 221 975 to 315 220 883	1	311-314
	8 63 - 7 64	296 brown cord pattern/brown - 51		
	8 63 - 7 64	298 grey cord pattern/grey - 50		
	8 63 - 7 64	299 olive cord pattern/olive - 52		
	8 64 - 7 65	166 olive cord pattern/pampas green - 52		
	8 64 - 7 65	169 silver cord pattern/Oxford grey - 53		
-	311 885 805 G	Cover - Rear seat backrest without arm rest (cloth) from Ch. No. 221 975 to 315 220 883	1	M 260
	8 63 - 7 64	296 brown cord pattern/brown - 51		
	8 63 - 7 64	298 grey cord pattern/grey - 52		
	8 63 - 7 64	299 olive cord pattern/olive - 52		
	8 64 - 7 65	166 olive cord pattern/pampas green - 52		
	8 64 - 7 65	169 silver cord pattern/Oxford grey - 53		
-	311 885 805 H	Cover - Rear seat backrest with arm rest (cloth) from Ch. No. 316 000 001 to 316 500 000	1	311-314
	8 65 - 7 66	125 platinum repp./platinum - 50		
	8 65 - 7 66	126 Teak repp./Teak - 51		
	8 65 - 7 66	127 azure repp./azure - 54		
-	311 885 805 J	Cover - Rear seat backrest with arm rest (leatherette) from Ch. No. 316 000 001 to 316 500 000	1	311-314
	8 65 - 7 66	041 black/black - 80		
	8 65 - 7 66	651 pigalle/pigalle - 79		
	8 65 - 7 66	667 Balearic beige/Balearic beige - 81		
	8 65 - 7 66	697 platinum/platinum - 78		

-	311 885 805 K	Cover - Rear seat backrest without arm rest (cloth) from Ch. No. 316 000 001 to 316 500 000	1	M 260
	8/65 - 7/66	125 platinum repp./platinum - 50		
	8/65 - 7/66	126 Teak repp./Teak - 51		
	8/65 - 7/66	127 azure repp./azure - 54		
-	311 885 805 L	Cover - Rear seat backrest without arm rest (leatherette) from Ch. No. 316 000 001 to 316 500 000	1	M 260
	8/65 - 7/66	041 black/black - 80		
	8/65 - 7/66	651 pigalle/pigalle - 79		
	8/65 - 7/66	667 Balearic beige/Balearic beige - 81		
	8/65 - 7/66	697 platinum/platinum - 78		
-	311 885 805 M	Cover - Rear set backrest with arm rest (cloth) from Ch. No. 317 000 001 to 318 500 000	1	311-314; M 234
	8/66 - 7/67	AC 5 khaki repp./khaki brown - 52		
	8/66 - 7/67	126 Teak repp./Teak - 51		
	8/66 - 7/67	127 azure repp./azure - 54		
	8/66 - 7/68	125 platinum repp./platinum - 01, 50		
-	311 885 805 N	Cover - Rear seat backrest with arm rest (leatherette) from Ch. No. 317 000 001 to 317 500 000	1	311-314; M 234
	8/66 - 7/67	041 black/black - 92		
	8/66 - 7/67	667 Balearic beige/Balearic beige - 93		
	8/66 - 7/67	697 platinum/platinum - 90		
	8/66 - 7/67	752 Indian red/Indian red - 91		
-	311 885 805 P	Cover - Backrest, rear without arm rest (cloth) from Ch. No. 317 000 001 to 318 500 000	1	M 260; M 260/M 234
	8/66 - 7/67	AC 5 khaki repp./khaki brown - 52		
	8/66 - 7/67	126 Teak repp./Teak - 51		
	8/66 - 7/67	127 azure repp./azure - 54		
	8/66 - 7/68	125 platinum repp./platinum - 01, 50		
-	311 885 805 Q	Cover - Backrest, rear without arm rest (leatherette) from Ch. No. 317 000 001 to 317 500 000	1	M 260; M 260/M 234
	8/66 - 7/67	041 black/black - 92		
	8/66 - 7/67	667 Balearic beige/Balearic beige - 93		
	8/66 - 7/67	697 platinum/platinum - 90		
	8/66 - 7/67	752 Indian red/Indian red - 91		
-	311 885 805 R	Cover - Backrest, rear without arm rest (cloth) from Ch. No. 318 000 001 to 311 2500 000	1	M 260; M 260/M 234
	8/67 - 7/68	AD 1 khaki repp./khaki brown 68 - 03		
	8/67 - 7/68	AD 2 blue repp. 68/Capri blue 68 - 04		
	8/67 - 7/68	AD 3 red repp. 68/Indian red 68 - 02		
	8/67 - 7/68	AD 4 platinum repp./black 68 - 08		

8/68 - 7/70	AF 4 grey stripe 69/quick grey 69 - 13		
8/68 - 7/70	AF 5 brown stripe 69/nut brown 69 - 15		
8/68 - 7/70	AF 6 blue stripe 69/Capri blue 68 - 14		
8/69 - 7/71	AH1 red stripe 70/gala red 69 - 01		
8/70 - 7/71	AJ5 blue stripe 71/blue 71 - 26		
8/70 - 7/71	AJ6 alabaster stripe 71/alabaster 71 - 27		
8/70 - 7/71	AJ7 cork stripe 71/cork 71 - 28		
58. 311 885 805 S	Cover - Backrest, rear with arm rest (cloth)	1	311-314; M 234
	from Ch. No. 318 000 001 to 311 2500 000		
8/67 - 7/68	AD 1 khaki repp./khaki brown 68 - 03		
8/67 - 7/68	AD 2 blue repp.68/Capri blue 68 - 04		
8/67 - 7/68	AD 3 red repp. 69/Indian red 68 - 02		
8/67 - 7/68	AD 4 platinum repp./black 68 - 08		
8/68 - 7/70	AF 4 grey stripe 69/quick grey 69 - 13		
8/68 - 7/70	AF 5 brown stripe 69/nut br wn 69 - 15		
8/68 - 7/70	AF 6 blue stripe 69/Capri blue 68 - 14		
8/69 - 7/71	AH 1 red stripe 70/gala red 69 - 01		
8/70 - 7/71	AJ5 blue stripe 71/blue 71 - 26		
8/70 - 7/71	AJ6 alabaster stripe 71/alabaster 71 - 27		
8/70 - 7/71	AJ7 cork stripe 71/cork 71 - 28		
- 311 885 805 T	Cover - Backrest, rear with arm rest (leatherette)	1	311-314; M 234
	from Ch. No. 318 000 001 to 311 2500 000		
8/67 - 7/68	AD 5 light sand 66/light sand 68 - 31		
8/67 - 7/68	AD 6 Indian red/Indian red 68 - 42		
8/67 - 7/68	AD 8 khaki brown/khaki brown 68 - 32		
8/68 - 7/70	718 nut brown 69/nut brown 69 - 48		
8/68 7/70	720 cream white 69/cream white 69 - 46		
8/67 - 7/71	AD 7 black/black 68 - 40, 43		
8/68 - 7/71	719 gala red 69/gala red 69 - 47		
8/70 - 7/71	AK2 alabaster 71 - 52		
8/70 - 7/71	AK4 cork 71 - 53		
- 311 885 805 AB	Cover - Backrest, rear without arm rest (leatherette)	1	M 260 ;M 260/M 234
	from Ch. No. 318 000 001 to 311 2500 000		
8/67 - 7/68	AD 5 light sand 66/light sand 68 - 31		
8/67 - 7/68	AD 6 Indian red/Indian red 68 - 42		
8/67 - 7/68	AD 8 khaki brown/khaki brown 68 - 32		
8/68 - 7/70	718 nut brown 69/nut brown 69 - 48		
8/68 - 7/70	720 cream white 69/cream white 69 - 46		
8/68 - 7/71	719 gala red 69/gala red 69 - 47		
8/67 - 7/71	AD 7 black/black 68 - 40, 43		
8/70 - 7/71	AK2 alabaster 71 - 52		
8/70 - 7/71	AK4 cork 71 - 53		

-	311 885 805 AG	Cover - Backrest, rear with arm rest (cloth) from Ch. No. 312 2000 001	1	311-314; M 234
	8 71 -	AV2 black - 12		
	8 71 -	AV3 alabaster - 13		
	8 71 -	AV4 leather beige - 14		
	8 71 -	AV5 lapis blue - 15		
	8 71 -	AV6 bordeaux red - 19		
-	311 885 805 AH	Cover - Backrest, rear without arm rest (cloth) from Ch. No. 312 2000 001	1	M 260; M 260/M 234
	8 71 -	AV2 black - 12		
	8 71 -	AV3 alabaster - 13		
	8 71 -	AV4 leather beige - 14		
	8 71 -	AV5 lapis blue - 15		
	8 71 -	AV6 bordeaux red - 19		
-	311 885 805 AJ	Cover - Backrest, rear with arm rest (leatherette) from Ch. No. 312 2000 001	1	311-314; M 234
	8 71 -	AW8 leather beige - 55		
	8 71 -	AW9 lapis blue - 56		
	8 71 -	AX1 bordeaux red - 57		
	8 71 -	AD7 black - 50		
	8 71 -	AK2 alabaster - 52		
-	311 885 805 AK	Cover - Backrest, rear without arm rest (leatherette) from Ch. No. 312 2000 001	1	M 260; M 260/M 234
	8 71 -	AW8 leather beige - 55		
	8 71 -	AW9 lapis blue - 56		
	8 71 -	AX1 bordeaux red - 57		
	8 71 -	AD7 black - 50		
	8 71 -	AK2 alabaster - 52		
-	315 885 805	Cover - Rear seat backrest (leatherette) from Ch. No. 221 975 to 315 220 883	1	315-318
	8 63 - 7/64	296 brown cord pattern/brown - 71		
	8 63 - 7/64	298 grey cord pattern/grey - 70		
	8 63 - 7/64	299 olive cord pattern/olive - 72		
	8 64 - 7/65	300 mesh grey/Oxford grey - 83		
	8 64 - 7/65	302 mesh green/pampas green - 86		
-	315 885 805 A	Cover - Rear seat backrest (cloth) from Ch. No. 315 000 001 to 315 220 883	1	315-318
	8 64 - 7 65	166 olive cord pattern/pampas green - 52		
	8 64 - 7 65	169 silver cord pattern/Oxford grey - 53		

-	315 885 805 C	Cover - Rear seat backrest (leatherette) from Ch. No. 316 000 001	1	315-318; M 233; M 237: 311-318
	8 65 - 2/66	495 mesh grey/platinum		
	3 66 - 7/66	697 platinum/platinum - 74		
	3 66 - 7/66	AE 2 black 66/black - 74		
	8 66 - 7/68	AC 3 dark platinum/platinum - 38, 86		
	8 68 - 7/70	AG 2 dark platinum/platinum 69 - 50		
	8 69 - 7/70	718 nut brown 69/nut brown 69 - 48		
	8 69 - 7/70	720 cream white 69/cream white 69 - 46		
	8 69 - 7/71	719 gala red 69/gala red 69 - 47		
	8 70 - 7/71	AK4 cork 71 - 53		
	8 66 -	AD7 black/black 68 - 40, 50, 88		
	8 70 -	AK2 alabaster 71 - 52		
	8 71 -	AW8 leather beige - 55		
	8 71 -	AW9 lapis blue - 56		
	8 71 -	AX1 bordeaux red - 57		
-	315 885 805 D	Cover - Rear seat backrest (cloth) from Ch. No. 316 000 001	1	315-318; M 233; M 237: 311-318
	8 65 - 7 68	131 platinum grid/platinum - 05, 55		
	8 68 - 7 69	AF 7 platinum grid/platinum 69 - 22		
	8 69 - 7 70	AG 4 platinum pattern/platinum 69 - 19		
	8 69 - 7 70	AF 2 red pattern 68/gala red 69 - 20		
	8 69 - 7 70	AF 3 blue pattern 68/Capri blue 68 - 21		
	8 70 - 7 71	AJ1 dogtooth blue 71/blue 71 - 16		
	8 70 - 7 71	AJ2 dogtooth grey 71/alabaster 71 - 17		
	8 70 - 7 71	AJ3 dogtooth red 71/gala red 69 - 18		
	8 70 - 7 71	AJ4 dogtooth cork 71/cork 71 - 22		
	8 70 - 7 71	AK7 dogtooth grey 71/black 68 - 08		
	8 71 -	AU6 black - 37		
	8 71 -	AI7 alabaster - 03		
	8 71 -	AU8 leather beige - 38		
	8 71 -	AU9 lapis blue - 05		
	8 71 -	AV1 bordeaux red - 10		
-	361 885 805	Cover - Rear seat backrest (cloth) to Ch. No. 221 974	1	361-364
	4 61 - 7 63	228 black-white/silver beige		
-	361 885 805 A	Cover - Rear seat backrest (leatherette) from Ch. No. 221 975 to 365 220 883	1	361-364
	8 63 - 7 64	295 red cord pattern/oxide red - 73		
	8 63 - 7 64	296 brown cord pattern/brown - 71		
	8 63 - 7 64	299 olive cord pattern/olive - 72		
	8 64 - 7 65	300 mesh grey/Oxford grey - 83		
	8 64 - 7 65	301 mesh red/oxide red - 87		
	8 64 - 7 65	302 mesh green/pampas green - 86		

-	361 885 805 B	Cover - Rear seat backrest (cloth) from Ch. No. 221 975 to 365 220 883	1	361-364
	8 63 - 7 64	296 brown cord pattern/brown - 51		
	8 63 - 7 64	298 grey cord pattern/grey - 50		
	8 63 - 7 64	299 olive cord pattern/olive - 52		
	8 64 - 7 65	166 olive cord pattern/pampas green - 52		
	8 64 - 7 65	169 silver cord pattern/Oxford grey - 53		
-	361 885 805 C	Cover - Rear seat backrest (cloth) from Ch. No. 366 000 001 to 366 500 000	1	361-364
	8 65 - 7 66	125 platinum repp./platinum - 50		
	8 65 - 7 66	126 teak repp./teak - 51		
	8 65 - 7 66	127 azure repp./azure - 54		
-	361 885 805 D	Cover - Rear seat backrest (leatherette) from Ch. No. 366 000 001 to 366 500 000	1	361-364
	8 65 - 7 66	041 black/black - 80		
	8 65 - 7 66	651 pigalle/pigalle - 79		
	8 65 - 7 66	667 Balearic beige/Balearic beige - 81		
	8 65 - 7 66	697 platinum/platinum - 78		
-	361 885 805 F	Cover - Rear seat backrest (cloth) from Ch. No. 367 000 001 to 367 180 000	1	361-364
	8 66 - 2 67	AC 5 khaki repp./khaki brown - 52		
	8 66 - 2 67	125 platinum repp./platinum - 50		
	8 66 - 2 67	126 teak repp./teak - 51		
	8 66 - 2 67	127 azure repp./azure - 54		
-	361 885 805 G	Cover - Rear seat backrest (leatherette) from Ch. No. 367 000 001 to 367 180 000	1	361-364
	8 66 - 2 67	041 black/black - 92		
	8 66 - 2 67	667 Balearic beige/Balearic beige - 93		
	8 66 - 2 67	697 platinum/platinum - 90		
	8 66 - 2 67	752 Indian red/Indian red - 91		
59	361 885 805 H	Cover - Rear seat backrest (cloth) from Ch. No. 367 180 001 to 361 2500 000	1	361-364
	3 67 - 7 67	AC 5 khaki repp./khaki brown - 52		
	3 67 - 7 67	126 teak repp./teak - 51		
	3 67 - 7 67	127 azure repp./azure - 54		
	3 67 - 7 68	125 platinum repp./platinum - 01, 50		
	8 67 - 7 68	AD 1 khaki repp./khaki brown 68 - 03		
	8 67 - 7 68	AD 2 blue repp. 68/Capri blue 68 - 04		
	8 67 - 7 68	AD 3 red repp. 68/Indian red 68 - 02		
	8 67 - 7 68	AD 4 platinum repp./black 68 - 08		
	8 68 - 7 70	AF 4 grey stripe 69/quick grey 69 - 13		

-	361 885 805 L	Cover - Rear seat backrest (leatherette) from Ch. No. 362 2000 001	1	361-364
	8/71 -	AD7 black - 50		
	8/71 -	AK2 alabaster - 52		
	8/71 -	AW8 leather beige - 55		
	8/71 -	AW9 lapis blue - 56		
	8/71 -	AX1 bordeaux red - 57		
-	365 885 805	Cover - Rear seat backrest (leatherette) from Ch. No. 221 975 to 365 220 883	1	365-368
	8/63 - 7/64	296 brown cord pattern/brown - 71		
	8/63 - 7/64	298 grey cord pattern/grey - 70		
	8/63 - 7/64	299 olive cord pattern/olive - 72		
	8/64 - 7/65	300 mesh grey/Oxford grey - 83		
	8/64 - 7/65	302 mesh green/pampas green - 86		
-	365 885 805 A	Cover - Rear seat backrest (cloth) from Ch. No. 365 000 001 to 365 220 883	1	365-368
	8/64 - 7/65	166 olive cord pattern/pampas green - 52		
	8/64 - 7/65	169 silver cord pattern/Oxford grey - 53		
-	365 885 805 B	Cover - Rear seat backrest (cloth) from Ch. No. 366 000 001 to 367 500 000	1	365-368
	8/65 - 7/67	131 platinum grid/platinum - 55		
-	365 885 805 C	Cover - Rear seat backrest (leatherette) from Ch. No. 366 000 001 to 367 500 000	1	365-368
	8/65 - 2/66	495 mesh grey/platinum		
	3/66 - 7/66	697 platinum/platinum - 74		
	3/66 - 7/66	AE 2 black 66/black - 76		
	8/66 - 7/67	AD 7 black/black 68 - 88		
	8/66 - 7/67	AC 3 dark platinum/platinum - 86		
-	365 885 805 E	Cover - Rear seat backrest (cloth) from Ch. No. 368 000 001 to 361 2500 000	1	365-368; M 237: 365-368
	8/67 - 7/68	131 platinum grid/platinum - 05		
	8/68 - 7/69	AF 7 platinum grid/platinum 69 - 22		
	8/69 - 7/70	AG 4 platinum pattern/platinum 69 - 19		
	8/69 - 7/70	AF 2 red pattern 68/gala red 69 - 20		
	8/69 - 7/70	AF 3 blue pattern 68/Capri blue 68 - 21		
	8/70 - 7/71	AJ1 dogtooth blue 71/blue 71 - 16		
	8/70 - 7/71	AJ2 dogtooth grey 71/alabaster 71 - 17		
	8/70 - 7/71	AJ3 dogtooth red 71/gala red 69 - 18		
	8/70 - 7/71	AJ4 dogtooth cork 71/cork 71 - 22		
	8/70 - 7/71	AK7 dogtooth grey 71/black 68 - 08		

-	365 885 805 F	Cover - Rear seat backrest (leatherette) from Ch. No. 368 000 001 to 361 2500 000	1	365-368; M 237: 365-368
	8/67 - 7/68	AC 3 dark platinum/platinum - 38		
	8/68 - 7/70	AG 2 dark platinum/platinum 69 - 50		
	8/69 - 7/70	718 nut brown 69/nut brown 69 - 48		
	8/69 - 7/70	720 cream white 69/cream white 69 - 46		
	8/69 - 7/71	719 gala red 69/gala red 69 - 47		
	8/67 - 7/71	AD 7 black/black 68 - 40		
	8/70 - 7/71	AK2 alabaster 71 - 52		
	8/70 - 7/71	AK4 cork 71 - 53		
-	365 885 805 K	Cover - Rear seat backrest (cloth) from Ch. No. 362 2000 001	1	365-368; M 237: 365-368
	8/71 -	AU6 black - 37		
	8/71 -	AU7 alabaster - 03		
	8/71 -	AU8 leather beige - 38		
	8/71 -	AU9 lapis blue - 05		
	8/71 -	AV1 bordeaux red - 10		
-	365 885 805 L	Cover - Rear seat backrest (leatherette) from Ch. No. 362 2000 001	1	365-368; M 237: 365-368
	8/71 -	AD7 black - 50		
	8/71 -	AK2 alabaster - 52		
	8/71 -	AW8 leather beige - 55		
	8/71 -	AW9 lapis blue - 56		
	8/71 -	AX1 bordeaux red - 57		
-	311 885 851 B	Cover - Arm rest (cloth) to Ch. No. 221 974	1	311-314
	4/61 - 7/63	228 black-white/silver beige		
-	311 885 851 C	Cover - Arm rest (leatherette) from Ch. No. 221 975 to 315 220 883	1	311-314
	8/63 - 7/64	295 red cord pattern/oxide red - 73		
	8/63 - 7/64	296 brown cord pattern/brown - 71		
	8/63 - 7/64	298 grey cord pattern/grey - 70		
	8/63 - 7/64	299 olive cord pattern/olive - 72		
	8/64 - 7/65	300 mesh grey/Oxford grey - 83		
	8/64 - 7/65	301 mesh red/oxide red - 87		
	8/64 - 7/65	302 mesh green/pampas green - 86		
-	311 885 851 D	Cover - Arm rest (cloth) from Ch. No. 221 975 to 315 220 883	1	311-314
	8/63 - 7/64	298 grey cord pattern/grey - 50		
	8/63 - 7/64	296 brown cord pattern/brown - 51		
	8/63 - 7/64	299 olive cord pattern/olive - 52		
	8/64 - 7/65	166 olive cord pattern/pampas green - 52		
	8/64 - 7/65	169 silver cord pattern/Oxford grey - 53		



60	311 885 851 E	Cover – Arm rest (cloth) from Ch. No. 316 000 001	1	311-314; M 234
	8/65 – 7/67	126 teak repp./teak – 51		
	8/66 – 7/67	127 azure repp./azure – 54		
	8/65 – 7/67	AC 5 khaki repp./khaki brown – 52		
	8/65 – 7/68	125 platinum repp./platinum – 01, 50		
	8/67 – 7/68	AD 1 khaki repp./khaki brown 68 – 03		
	8/67 – 7/68	AD 2 blue repp. 68/Capri blue 68 – 04		
	8/67 – 7/68	AD 3 red repp. 68/Indian red 68 – 02		
	8/67 – 7/68	AD 4 platinum repp./black 68 – 08		
	8/68 – 7/70	AF 4 grey stripe 69/quick grey 69 – 13		
	8/68 – 7/70	AF 5 brown stripe 69/nut brown 69 – 15		
	8/68 – 7/70	AF 6 blue stripe 69/Capri blue 68 – 14		
	8/69 – 7/71	AH 1 red stripe 70/gala red 69 – 01		
	8/70 – 7/71	AJ5 blue stripe 71/blue 71 – 26		
	8/70 – 7/71	AJ6 alabaster stripe 71/alabaster 71 – 27		
	8/70 – 7/71	AJ7 cork stripe 71/cork 71 – 28		
	8/71 –	AV2 black – 12		
	8/71 –	AV3 alabaster – 13		
	8/71 –	AV4 leather beige – 14		
	8/71 –	AV5 lapis blue – 15		
	8/71 –	AV6 bordeaux red – 19		
–	311 885 851 F	Cover – Arm rest (leatherette) from Ch. No. 316 000 001	1	311-314; M 234
	8/65 – 7/66	651 pigalle/pigalle – 79		
	8/65 – 7/67	041 black/black – 80, 92		
	8/65 – 7/67	667 Balearic beige/Balearic beige – 81, 93		
	8/65 – 7/67	697 platinum/platinum – 78, 90		
	8/66 – 7/67	752 Indian red/Indian red – 91		
	8/67 – 7/68	AD 5 light sand 66/light sand 68 – 31		
	8/67 – 7/68	AD 6 Indian red/Indian red 68 – 42		
	8/67 – 7/68	AD 8 khaki brown/khaki brown 68 – 32		
	8/68 – 7/70	718 nut brown 69/nut brown 69 – 48		
	8/68 – 7/70	720 cream white 69/cream white 69 – 46		
	8/68 – 7/71	719 gala red 69/gala red 69 – 47		
	8/70 – 7/71	AK4 cork 71 – 53		
	8/67 –	AD 7 black/black 68 – 40, 43, 50		
	8/70 –	AK2 alabaster 71 – 52		
	8/71 –	AW8 leather beige – 55		
	8/71 –	AW9 lapis blue – 56		
	8/71 –	AX1 bordeaux red – 57		
61	N 12 056 1	Clamping plate 6	1	311-314; M 234

**MAIN GROUP 8**

**BODY**

Key	Part No.	Description	Qty.	Type and model
		<b>REPAIR KITS</b>		
<b>111 898 041 B</b>		<b>1 set of tumblers for lock cylinders K</b> from Ch. No. 317 000 001 to 317 500 000 comprising:		
		Tumbler No. 1	50	
		Tumbler No. 2	50	
		Tumbler No. 3	50	
		Spring - Tumbler	100	
<b>111 898 041 C</b>		<b>1 set of tumblers</b> <b>for lock cylinders 111 837 217 D (profile K)</b> from Ch. No. 318 000 001 to 310 2500 000 comprising:		
		Tumbler No. 1	50	
		Tumbler No. 2	50	
		Tumbler No. 3	50	
		Tumbler No. 4	50	
		Spring - Tumbler	150	
<b>111 898 041 D</b>		<b>1 set of tumblers</b> <b>for lock cylinder 13.5 mm (Profile M)</b> from Ch. No. 311 2000 001 comprising:		
		Tumbler No. 1	50	
		Tumbler No. 2	50	
		Tumbler No. 3	50	
		Spring - Tumbler	100	
<b>211 898 041 A</b>		<b>1 set of tumblers for lock cylinder</b> <b>12 mm dia. (Profile M) (Rear door)</b> from Ch. No. 311 2000 001:361-368 comprising:		
		Tumbler No. 1	50	
		Tumbler No. 2	50	
		Tumbler No. 3	50	
		Spring - Tumbler	100	
<b>311 898 041</b>		<b>1 set of tumblers for lock cylinders A</b> to Ch. No. 316 500 000 comprising:		
		Tumbler No. 1	50	
		Tumbler No. 2	50	
		Tumbler No. 3	50	
		Spring - Tumbler	100	

8 68 - 7 70	AF 5 brown stripe 69/nut brown 69 - 15		
8 68 - 7 70	AF 6 blue stripe 69/Capri blue 68 - 14		
8 69 - 7 71	AH 1 red stripe 70/gala red 69 - 01		
8 70 - 7 71	AJ5 blue stripe 71/blue 71 - 26		
8 70 - 7 71	AJ6 alabaster stripe 71/alabaster 71 - 27		
8 70 - 7 71	AJ7 cork stripe 71/cork 71 - 28		
- 361 885 805 J	Cover - Rear seat backrest	1	361-364
	(leatherette)		
	from Ch. No. 367 180 001 to 361 2500 000		
3 67 - 7 67	041 black/black - 92		
3 67 - 7 67	667 Balearic beige/Balearic beige - 93		
3 67 - 7 67	697 platinum/platinum - 90		
3 67 - 7 67	752 Indian red/Indian red - 91		
8 67 - 7 68	AD 5 light sand 66/light sand 68 - 31		
8 67 - 7 68	AD 6 Indian red/Indian red 68 - 42		
8 67 - 7 68	AD 8 khaki brown/khaki brown 68 - 32		
8 68 - 7 70	718 nut brown 69/nut brown 69 - 48		
8 68 - 7 70	720 cream white 69/cream white 69 - 46		
8 67 - 7 71	AD 7 black/black 68 - 40, 43		
8 68 - 7 71	719 gala red 69/gala red 69 - 47		
8 70 - 7 71	AK2 alabaster 71 - 52		
8 70 - 7 71	AK4 cork 71 - 53		
- 361 885 805 K	Cover - Rear seat backrest	1	361-364
	(cloth)		
	from Ch. No. 362 2000 001		
8 71 -	AV2 black - 12		
8 71 -	AV3 alabaster - 13		
8 71 -	AV4 leather beige - 14		
8 71 -	AV5 lapis blue - 15		
8 71 -	AV6 bordeaux red - 19		
- 361 885 805 L	Cover - Rear seat backrest	1	361-364
	(leatherette)		
	from Ch. No. 362 2000 001		
8 71 -	AD7 black - 50		
8 71 -	AK2 alabaster - 52		
8 71 -	AW8 leather beige - 55		
8 71 -	AW9 lapis blue - 56		
8 71 -	AX1 bordeaux red - 57		
- 365 885 805	Cover - Rear seat backrest	1	365-368
	(leatherette)		
	from Ch. No. 221 975 to 365 220 883		
8 63 - 7 64	296 brown cord pattern/brown - 71		
8 63 - 7 64	298 grey cord pattern/grey - 70		
8 63 - 7 64	299 olive cord pattern/olive - 72		
8 64 - 7 65	300 mesh grey/Oxford grey - 83		
8 64 - 7 65	302 mesh green/pampas green - 86		

-	365 885 805 A	Cover - Rear seat backrest (cloth) from Ch. No. 365 000 001 to 365 220 883	1	365-368
	8 64 - 7 65	166 olive cord pattern/pampas green - 52		
	8 64 - 7 65	169 silver cord pattern/Oxford grey - 53		
-	365 885 805 B	Cover - Rear seat backrest (cloth) from Ch. No. 366 000 001 to 367 500 000	1	365-368
	8 65 - 7 67	131 platinum grid/platinum - 55		
-	365 885 805 C	Cover - Rear seat backrest (leatherette) from Ch. No. 366 000 001 to 367 500 000	1	365-368
	8 65 - 2 66	495 mesh grey/platinum		
	3 66 - 7 66	697 platinum/platinum - 74		
	3 66 - 7 66	AE 2 black 66/black - 76		
	8 66 - 7 67	AD 7 black/black 68 - 88		
	8 66 - 7 67	AC 3 dark platinum/platinum - 86		
-	365 885 805 E	Cover - Rear seat backrest (cloth) from Ch. No. 368 000 001 to 361 2500 000	1	365-368; M 237: 365-368
	8 67 - 7 68	131 platinum grid/platinum - 05		
	8 68 - 7 69	AF 7 platinum grid/platinum 69 - 22		
	8 69 - 7 70	AG 4 platinum pattern/platinum 69 - 19		
	8 69 - 7 70	AF 2 red pattern 68/gala red 69 - 20		
	8 69 - 7 70	AF 3 blue pattern 68/Capri blue 68 - 21		
	8 70 - 7 71	AJ1 dogtooth blue 71/blue 71 - 16		
	8 70 - 7 71	AJ2 dogtooth grey 71/alabaster 71 - 17		
	8 70 - 7 71	AJ3 dogtooth red 71/gala red 69 - 18		
	8 70 - 7 71	AJ4 dogtooth cork 71/cork 71 - 22		
	8 70 - 7 71	AK7 dogtooth grey 71/black 68 - 08		
-	365 885 805 F	Cover - Rear seat backrest (leatherette) from Ch. No. 368 000 001 to 361 2500 000	1	365-368; M237: 365-368
	8 67 - 7 68	AC 3 dark platinum/platinum - 38		
	8 68 - 7 70	AG 2 dark platinum/platinum 69 - 50		
	8 69 - 7 70	718 nut brown 69/nut brown 69 - 48		
	8 69 - 7 70	720 cream white 69/cream white 69 - 46		
	8 69 - 7 71	719 gala red 69/gala red 69 - 47		
	8 67 - 7 71	AD 7 black/black 68 - 40		
	8 70 - 7 71	AK2 alabaster 71 - 52		
	8 70 - 7 71	AK4 cork 71 - 53		
-	365 885 805 K	Cover - Rear seat backrest (cloth) from Ch. No. 362 2000 001	1	365-368; M237:365-368
	8 71 -	AU6 black - 37		
	8 71 -	AU7 alabaster - 03		
	8 71 -	AU8 leather beige - 38		
	8 71 -	AU9 lapis blue - 05		
	8 71 -	AV1 bordeaux red - 10		

**361 898 081 A****1 set of lock cylinders for door,  
rear door and ignition/starter**

from Ch. No. 367 000 001 to 367 500 000: 361-364

comprising:

361 827 539 A	Press button – Rear door lock	1
311 837 217 A	Lock cylinder – Door	2
111 837 219 A	Key S66 Profile K	2
311 905 853	Lock cylinder – Ignition/starter lock	1

**361 898 081 B****1 lock cylinder set for door handle,  
rear flap and ignition/starter switch**

from Ch. No. 368 000 001 to 360 2500 000:361-368

comprising:

361 827 539 A	Press button – Rear door lock	1
111 837 217 D	Lock cylinder – Door handle	2
111 837 219 A	Key S66 Profile K	2
311 905 853	Lock cylinder – Ignition starter switch	1

**361 898 081 C****1 set of lock cylinders dor door,  
rear door and ignition/starter switch**

from Ch. No. 361 2000 001:361-368

comprising:

361 827 539 A	Press button – Rear door lock	1
111 837 217 E	Lock cylinder – Door handle	2
111 837 219 A	Key S 92 Profile M	2
111 905 855 A	Lock cylinder – Ignition/starter switch	1

**311 898 105****1 set of hinged quarter windows  
for service installation in Model : 311-314**

comprising:

N 11 114 1	Hinged quarter window left	1
N 15 912 2	Hinged quarter window right	1
N 16 183 1	Threaded plate	2
	Nut, hex. BM 4	8
	Tapping screw, csk. raised hd. A 6.5 x 25	4
	Rivet 3, 2 x 5, 1	14

**315 898 105****1 set of hinged quarter windows  
for service installation in Model 315-318**

comprising:

311 847 131 A	Reinforcement, left	1
N 11 004 2	Reinforcement, right	1
N 11 462 1	Threaded plate	2
N 14 256 1	Hinged quarter window left	1
N 15 913 2	Hinged quarter window right	1
	Beading	2
	Nut, hex. M 4	8
	Tapping screw, csk. raised hd. B 3.5 x 19	2
	Screw, csk. raised hd. AM 4 x 18	8
	Tapping screw, csk. raised hd. A 4.3 x 22	6

365 898 105

**1 set of hinged quarter windows  
for service installation in Model 361-368**

comprising:

	Reinforcement, left	1
	Reinforcement, right	1
	Threaded plate	2
	Hinged quarter window left	1
	Hinged quarter window right	1
361 847 131 B	Beading	2
N 11 004 2	Nut, hex. M 4	8
N 11 462 1	Tapping screw, csk. raised hd. B 3.5 x 19	2
N 14 256 1	Screw, csk. raised hd. AM 4 x 18	8
N 14 095 1	Tapping screw, csk. raised hd. B 4.2 x 19	6

**311 898 111**

**1 set of moldings for service installation**

to Ch. No. 316 500 000

comprising:

311 853 507 C	Molding - Fender, front	2
311 853 509 A	Molding - Fender, rear	2
311 853 515 B	Molding - Door	2
113 853 585 B	Retaining clip - Molding	35
113 857 219 A	Seal - Molding retaining clip	35
311 853 591 C	Packing, black - Grip molding	1
311 853 595 C	Grip molding - Hood, front	1
N 10 210 1	Bolt, hex. hd. M 6 x 10	3
N 12 226 2	Spring washer B 6	3

**311 898 111 A**

**1 set of moldings for service installation**

from Ch. No. 317 000 001

comprising:

311 853 507 E	Molding - Fender, front	2
311 853 509 B	Molding - Fender, rear	2
311 853 515 C	Molding - Door	2
113 853 585 C	Plastic clip - Molding	34
311 853 591 C	Packing, black - Grip molding	1
311 853 595 C	Grip molding - Hood, front	1
N 14 140 1	Screw, fillister hd. AM 6 x 15	4
N 12 226 2	Spring washer B 6	4



-	365 885 805 L	Cover - Rear seat backrest (leatherette) from Ch. No. 362 2000 001	1	365-368; M 237:365-368
	8 71 -	AD7 black - 50		
	8 71 -	AK2 alabaster - 52		
	8 71 -	AW8 leather beige - 55		
	8 71 -	AW9 lapis blue - 56		
	8 71 -	AX1 bordeaux red - 57		
-	311 885 851 B	Cover - Arm rest (cloth) to Ch. No. 221 974	1	311-314
	4 61 - 7 63	228 black-white/silver beige		
-	311 885 851 C	Cover - Arm rest (leatherette) from Ch. No. 221 975 to 315 220 883	1	311-314
	8 63 - 7 64	295 red cord pattern/oxide red - 73		
	8 63 - 7 64	296 brown cord pattern/brown - 71		
	8 63 - 7 64	298 grey cord pattern/grey - 70		
	8 63 - 7 64	299 olive cord pattern/olive - 72		
	8 64 - 7 65	300 mesh grey/Oxford grey - 83		
	8 64 - 7 65	301 mesh red/oxide red - 87		
	8 64 - 7 65	302 mesh green/pampas green - 86		
-	311 885 851 D	Cover - Arm rest (cloth) from Ch. No. 221 975 to 315 220 883	1	311-314
	8 63 - 7 64	298 grey cord pattern/grey - 50		
	8 63 - 7 64	296 brown cord pattern/brown - 51		
	8 63 - 7 64	299 olive cord pattern/olive - 52		
	8 64 - 7 65	166 olive cord pattern/pampas green - 52		
	8 64 - 7 65	169 silver cord pattern/Oxford grey - 53		
60	311 885 851 E	Cover - Arm rest (cloth) from Ch. No. 316 000 001	1	311-314; M 234
	8 65 - 7 67	126 teak repp./teak - 51		
	8 66 - 7 67	127 azure repp./azure - 54		
	8 65 - 7 67	AC 5 khaki repp./khaki brown - 52		
	8 65 - 7 68	125 platinum repp./platinum - 01, 50		
	8 67 - 7 68	AD 1 khaki repp./khaki brown 68 - 03		
	8 67 - 7 68	AD 2 blue repp. 68/Capri blue 68 - 04		
	8 67 - 7 68	AD 3 red repp. 68/Indian red 68 - 02		
	8 67 - 7 68	AD 4 platinum repp./black 68 - 08		
	8 68 - 7 70	AF 4 grey stripe 69/quick grey 69 - 13		
	8 68 - 7 70	AF 5 brown stripe 69/nut brown 69 - 15		
	8 68 - 7 70	AF 6 blue stripe 69/Capri blue 68 - 14		
	8 69 - 7 71	AH 1 red stripe 70/gala red 69 - 01		
	8 70 - 7 71	AJ5 blue stripe 71/blue 71 - 26		
	8 70 - 7 71	AJ6 alabaster stripe 71/alabaster 71 - 27		
	8 70 - 7 71	AJ7 cork stripe 71/cork 71 - 28		
	8 71 -	AV2 black - 12		
	8 71 -	AV3 alabaster - 13		
	8 71 -	AV4 leather beige - 14		
	8 71 -	AV5 lapis blue - 15		
	8 71 -	AV6 bordeaux red - 19		



311 885 851 F	Cover - Arm rest (leatherette)	1	311-314; M 234
	from Ch. No. 316 000 001		
8/65 - 7/66	651 pigalle/pigalle - 79		
8/65 - 7/67	041 black/black - 80, 92		
8/65 - 7/67	667 Balearic beige/Balearic beige - 81, 93		
8/55 - 7/67	697 platinum/platinum - 78, 90		
8/66 - 7/67	752 Indian red/Indian red - 91		
8/67 - 7/68	AD 5 light sand 66/light sand 68 - 31		
8/67 - 7/68	AD 6 Indian red/Indian red 68 - 42		
8/67 - 7/68	AD 8 khaki brown/khaki brown 68 - 32		
8/68 - 7/70	718 nut brown 69/nut brown 69 - 48		
8/68 - 7/70	720 cream white 69/cream white 69 - 46		
8/68 - 7/71	719 gala red 69/gala red 69 - 47		
8/70 - 7/71	AK4 cork 71 - 53		
8/67 -	AD 7 black/black 68 - 40, 43, 50		
8/70 -	AK2 alabaster 71 - 52		
8/71 -	AW8 leather beige - 55		
8/71 -	AW9 lapis blue - 56		
8/71 -	AX1 bordeaux red - 57		
61 N 12 056 1	Clamping plate 6	1	311-314; M 234

**MAIN GROUP 8**

**BODY**

Key Part No. Description Qty. Type and model

**REPAIR KITS**

**111 898 041 B** **1 set of tumblers for lock cylinders K**  
 from Ch. No. 317 000 001 to 317 500 000  
 comprising:  
 Tumbler No. 1 50  
 Tumbler No. 2 50  
 Tumbler No. 3 50  
 Spring - Tumbler 100

**111 898 041 C** **1 set of tumblers**  
**for lock cylinders 111 837 217 D (profile K)**  
 from Ch. No. 318 000 001 to 310 2500 000  
 comprising:  
 Tumbler No. 1 50  
 Tumbler No. 2 50  
 Tumbler No. 3 50  
 Tumbler No. 4 50  
 Spring - Tumbler 150

**111 898 041 D** **1 set of tumblers**  
**for lock cylinder 13.5 mm (Profile M)**  
 from Ch. No. 311 2000 001  
 comprising:  
 Tumbler No. 1 50  
 Tumbler No. 2 50  
 Tumbler No. 3 50  
 Spring - Tumbler 100

**211 898 041 A** **1 set of tumblers for lock cylinder**  
**12 mm dia. (Profile M) (Rear door)**  
 from Ch. No. 311 2000 001:361-368  
 comprising:  
 Tumbler No. 1 50  
 Tumbler No. 2 50  
 Tumbler No. 3 50  
 Spring - Tumbler 100

**311 898 041** **1 set of tumblers for lock cylinders A**  
 to Ch. No. 316 500 000  
 comprising:  
 Tumbler No. 1 50  
 Tumbler No. 2 50  
 Tumbler No. 3 50  
 Spring - Tumbler 100

<b>311 898 051</b>	<b>1 set of securing parts for 1 fender, front</b>	
	to Ch. No. 319 190 521	
	comprising:	
311 821 143	Tapping screw, hex. hd.	13
311 821 161	Speed nut	13
311 821 185	Washer	14
N 10 216 8	Bolt, hex. hd. M 6 x 18	1
N 11 695 2	Washer 6.1	2
N 13 890 2	Tapping screw, hex. hd. B 6.3 x 13	1
<b>311 898 051 A</b>	<b>1 set of securing parts for 1 fender, front</b>	
	from Ch. No. 319 190 522	
	comprising:	
311 821 143	Tapping screw, hex. hd.	11
311 821 161	Speed nut	11
311 821 185	Rubber washer	1
311 821 187	Spacer plate	2
311 821 189	Rubber washer	2
N 10 240 4	Screw, hex. hd. M 8 x 20	2
<b>311 898 053</b>	<b>1 set of securing parts for 1 fender, rear</b>	
	comprising:	
311 821 143	Tapping screw, hex. hd.	11
311 821 161	Speed nut	11
311 821 185	Washer	12
311 821 399	Cap – Tapping screw	1
N 10 216 8	Bolt, hex. hd. M 6 x 18	4
N 11 695 2	Washer 6.1	4
N 11 372 3	Tapping screw, cheese hd. B 3.9 x 6.5	1
N 13 957 3	Tapping screw BZ 3.5 x 9.5	1
<b>311 898 075 B</b>	<b>1 set of door hinge parts</b>	
	from Ch. No. 316 000 001:311-314	
	from Ch. No. 366 111 025:361-368	
	comprising:	
311 831 405 C	Hinge half	2
311 831 421 D	Pin – Hinge	2
311 831 439 A	Plug – Door hinge	2
311 831 443	Spring washer – Hinge	2
N 14 289 3	Screw, csk. raised hd. AM 8 x 18 – Door hinge	4
<b>311 898 075 C</b>	<b>1 set of door hinge parts, left</b>	
	to Ch. No. 315 220 883: 311-318	
	to Ch. No. 366 111 024: 361-368	
	from Ch. No. 316 000 001: 315-318	
	comprising:	
311 831 405 D	Hinge half, upper	1
311 831 415 B	Hinge half, lower	1
311 831 421 D	Pin – Hinge	2
311 831 439 A	Plug – Door hinge	2
311 831 443	Spring washer – Hinge	2
311 831 455	Screw – Door hinge	6

**311 898 076 A****1 set of door hinge parts, right**

to Ch. No. 315 220 883: 311-318  
 to Ch. No. 366 111 024: 361-368  
 from Ch. No. 316 000 001: 315-318  
 comprising:

311 831 406 B	Hinge half, upper	1
311 831 416 B	Hinge half, lower	1
311 831 421 D	Pin – Hinge	2
311 831 439 A	Plug – Door hinge	2
311 831 443	Spring washer – Hinge	2
311 831 455	Screw – Door hinge	6

**311 898 081 A****1 door lock cylinder set  
and ignition/starter lock**

from Ch. No. 317 000 001 to 317 500 000: 311-314  
 comprising:

311 837 217 A	Lock cylinder – Door	2
111 837 219 A	Key S66 Profile K	2
311 905 853	Lock cylinder – Ignition/starter lock	1

**311 898 081 C****1 lock cylinder set****for door handle and ignition starter switch**

from Ch. No. 311 2000 001:311-318  
 comprising:

111 837 217 E	Lock cylinder – Door handle	2
111 837 219 A	Key S 92 Profile M	2
113 905 855 A	Lock cylinder – Ignition starter switch	1

**361 898 081****1 set of lock cylinders for door  
and rear door**

to Ch. No. 366 500 000: 361-364  
 comprising:

311 837 217	Lock cylinder	2
361 827 539	Press button – Rear door lock	1
111 837 219 A	Key S80 Profile A	2

**361 898 081 A****1 set of lock cylinders for door,  
rear door and ignition/starter**

from Ch. No. 367 000 001 to 367 500 000: 361-364  
 comprising:

361 827 539 A	Press button – Rear door lock	1
311 837 217 A	Lock cylinder – Door	2
111 837 219 A	Key S66 Profile K	2
311 905 853	Lock cylinder – Ignition/starter lock	1

**361 898 081 C****1 set of lock cylinders dor door,  
rear door and ignition/starter switch**

from Ch.No. 361 2000 001 to 361 2500 000:361-368  
 comprising:

361 827 539 A	Press button – Rear door lock	1
111 837 217 E	Lock cylinder – Door handle	2
111 837 219 A	Key S 92 Profile M	2
111 905 855 A	Lock cylinder – Ignition/starter switch	1

361 898 081 D

**1 set of lock cylinders for door,  
rear door and ignition starter switch**

from Ch. No. 362 2000 001

comprising:

361 827 539 B	Press button – Rear door lock	1
111 837 217 E	Lock cylinder for door	2
111 837 219 A	Key S92 Profile M	2
111 905 855 A	Lock cylinder – Ignition starter switch	1

**311 898 105**

**1 set of hinged quarter windows**

**for service installation in Model : 311-314**

comprising:

N 11 114 1	Hinged quarter window left	1
N 15 912 2	Hinged quarter window right	1
N 16 183 1	Threaded plate	2
	Nut, hex. BM 4	8
	Tapping screw, csk. raised hd. A 6.5 x 25	4
	Rivet 3, 2 x 5, 1	14

**315 898 105**

**1 set of hinged quarter windows**

**for service installation in Model 315-318**

comprising:

311 847 131 A	Reinforcement, left	1
N 11 004 2	Reinforcement, right	1
N 11 462 1	Threaded plate	2
N 14 256 1	Hinged quarter window left	1
N 15 913 2	Hinged quarter window right	1
	Beading	2
	Nut, hex. M 4	8
	Tapping screw, csk. raised hd. B 3.5 x 19	2
	Screw, csk. raised hd. AM 4 x 18	8
	Tapping screw, csk. raised hd. A 4.3 x 22	6

**365 898 105**

**1 set of hinged quarter windows**

**for service installation in Model 361-368**

comprising:

361 847 131 B	Reinforcement, left	1
N 11 004 2	Reinforcement, right	1
N 11 462 1	Threaded plate	2
N 14 256 1	Hinged quarter window left	1
N 14 095 1	Hinged quarter window right	1
	Beading	2
	Nut, hex. M 4	8
	Tapping screw, csk. raised hd. B 3.5 x 19	2
	Screw, csk. raised hd. AM 4 x 18	8
	Tapping screw, csk. raised hd. B 4.2 x 19	6

311 898 111

**1 set of moldings for service installation**

to Ch. No. 316 500 000

comprising:

311 853 507 C	Molding – Fender, front	2
311 853 509 A	Molding – Fender, rear	2
311 853 515 B	Molding – Door	2
113 853 585 B	Retaining clip – Molding	35
113 857 219 A	Seal – Molding retaining clip	35
311 853 591 C	Packing, black – Grip molding	1
311 853 595 C	Grip molding – Hood, front	1
N 10 210 1	Bolt, hex. hd. M 6 x 10	3
N 12 226 2	Spring washer B 6	3

**311 898 111 A**

**1 set of moldings for service installation**

from Ch. No. 317 000 001

comprising:

311 853 507 E	Molding – Fender, front	2
311 853 509 B	Molding – Fender, rear	2
311 853 515 C	Molding – Door	2
113 853 585 C	Plastic clip – Molding	34
311 853 591 C	Packing, black – Grip molding	1
311 853 595 C	Grip molding – Hood, front	1
N 14 140 1	Screw, fillister hd. AM 6 x 15	4
N 12 226 2	Spring washer B 6	4

ADDENDUM-CLOTH

The following materials are supplied in lengths. 1 length corresponds to 25 cm × width of length. The last two digits of the part number Denote the width in dm (1 dm = 10 cm = APPROX. 4 in.). A Letter "B" at the end of the part number signifies a lighter quality.

Example:

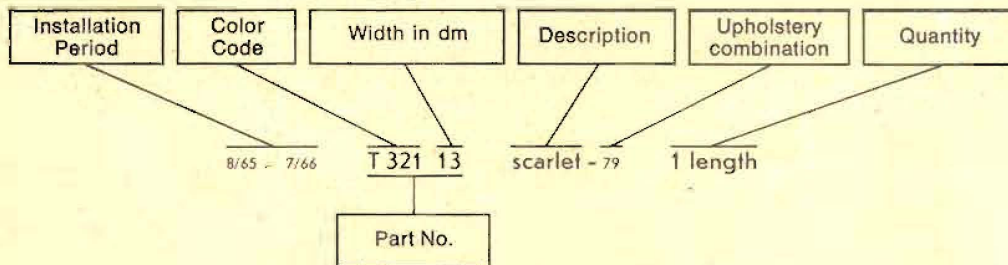

A new part number for Cloth Material has been changed for lengths introduced from 1<sup>st</sup> August 1966 on, as well as for those Materials remaining in current production. The 7<sup>th</sup> to 9<sup>th</sup> digits in the Part No. Denote the bale width in cm (1 cm = 0.39 in.).

Example:

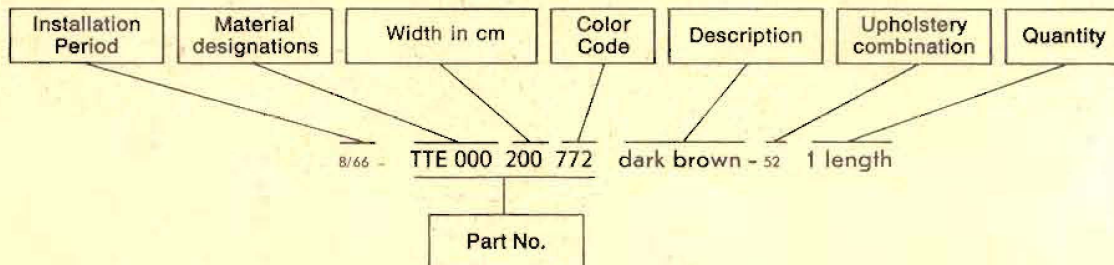

**MAIN GROUP 8**

**BODY**

Installation

Period                      Part No.                      Description                      Quantity

**ADDENDUM - CLOTH**

**Upholstery leatherette**

8 63 - 7 64	K 424 13	brown - 51,71	1 length
8 63 - 2 64	K 426 13	olive - 52,72	1 length
8 63 - 7 64	K 433 14	red cord pattern (air-permeable) - 73	1 length
8 63 - 2 64	K 435 14	olive cord pattern (air-permeable) - 72	1 length
8 63 - 7 65	K 438 13	oxide red - 73,87	1 length
8 64 - 7 65	K 444 13	pampas green - 52,86	1 length
8 64 - 7 65	K 453 14	mesh red (air-permeable) - 87	1 length
8 64 - 7 65	K 454 14	mesh green (air-permeable) - 86	1 length
8 65 - 7 66	SK 001 14	platinum (air-permeable) - 78	1 length
8 65 - 7 66	SK 002 14	pigalle (air-permeable) - 79	1 length
8 65 - 7 66	SK 003 14	Balearic beige (air-permeable) - 81	1 length
8 65 - 7 66	SK 004 14	black (air-permeable) - 80	1 length
8 65 - 7 66	SK 008 13	pigalle (air-permeable) - 79	1 length
8 63 - 7 64	BPL 000 130 528	grey - 50,70	1 length
8 64 - 7 65	BPF 000 142 379	mesh grey (air-permeable) - 83	1 length
8 65 -	BSX 000 130 041	black - 76,80,88,92	1 length
8 65 -	BSX 000 130 637	azure - 54	1 length
8 65 -	BSX 000 130 667	Balearic beige - 81,93	1 length
8 65 -	BSX 000 130 671	Teak - 51	1 length
8 65 -	BSX 000 130 697	platinum - 50,55,78,90	1 length
8 66 -	BSX 000 130 752	Indian red - 91	1 length
8 66 -	BSX 000 130 762	khaki brown - 52	1 length
8 66 -	BPA 000 135 141	dark platinum (air-permeable) - 86	1 length
8 66 -	BSA 000 145 041	black (air-permeable) - 92	1 length
8 66 -	BSA 000 145 667	Balearic beige (air-permeable) - 93	1 length
8 66 -	BSA 000 145 697	platinum (air-permeable) - 90	1 length
8 66 -	BSA 000 145 752	Indian red (air-permeable) - 91	1

**Headlining leatherette**

4 61 - 7 64	K 372 10 B	silver beige, unpunched	1 length
4 61 - 7 64	K 376 15 B	silver beige, imitation punching	1 length
8 64 - 7 65	K 458 13 B	cloud white	1 length
8 64 -	BAB 000 150 581	cloud white, imitation punching	1 length
8 64 -	BBB 000 155 581	cloud white, unpunched	1 length
8 64 -	BCB 000 155 581	cloud white, punched	1 length
8 66 -	BBX 000 027 041	black - 92	1 length
8 66 -	BBX 000 027 637	azure - 54	1 length
8 66 -	BBX 000 027 662	khaki brown - 52	1 length
8 66 -	BBX 000 027 667	Balearic beige - 93	1 length
8 66 -	BBX 000 027 697	platinum - 50,90	1 length
8 66 -	BBX 000 027 752	Indian red - 91	1 length



8 65 - 7 66 KsK 105 13  
 8 65 - FAX 000 064 041  
 8 65 - FAX 000 064 637  
 8 65 - FAX 000 130 667  
 8 65 - FAX 000 130 671  
 8 65 - FAX 000 130 697  
 8 66 - FAX 000 058 752  
 8 66 - FAX 000 058 762

4 61 - 7 63 P 300 15  
 8 63 - 7 64 P 353 14  
 8 63 - 7 65 P 355 14  
 8 65 - TPA 000 145 100  
 8 65 - TPA 000 145 101  
 8 65 - TPA 000 145 102  
 8 65 - TPA 000 145 106  
 8 66 - TPA 000 145 144

4 61 - 7 64 TTE 000 133 046  
 8 64 - 7 65 T 308 20  
 8 65 - 7 66 T 321 13  
 8 65 - TTE 000 133 046  
 8 65 - TTE 000 133 634  
 8 65 - TTE 000 133 662  
 8 65 - TTE 000 133 672  
 8 66 - TTE 000 200 772

8 63 - 7 64 Ke 79  
 8 63 - 7 64 Ke 90  
 8 63 - 7 65 Ke 80  
 8 64 - 7 65 Ke 81  
 8 64 - 7 65 Ke 84  
 8 65 - 7 66 Ke 106  
 8 65 - KKZ 000 246 041  
 8 65 - KKZ 000 246 180  
 8 65 - KKZ 000 246 183  
 8 65 - KKZ 000 246 184  
 8 66 - KKZ 000 246 149  
 8 66 - KKZ 000 246 752

**Plastic material**

pigalle - 79 1 length  
 black - 80,92 1 length  
 azure - 54 1 length  
 Balearic beige - 81,93 1 length  
 Teak - 51 1 length  
 platinum - 50,90 1 length  
 Indian red - 91 1 length  
 khaki brown - 52 1 length

**Upholstery material**

black-white 1 length  
 grey cord pattern - 50 1 length  
 olive cord pattern - 52 1 length  
 platinum repp. - 50 1 length  
 teak repp. - 51 1 length  
 azure repp. - 54 1 length  
 platinum grid - 55 1 length  
 repp. khaki - 52 1 length

**Carpet material**

lava 1 length  
 tin grey 1 length  
 scarlet - 79 1 length  
 lava - 50,55,78,80,83,90,91,92 1 length  
 ultra blue - 54 1 length  
 almond beige - 81,93 1 length  
 rust - 51 1 length  
 dark brown - 52 1 length

**Beading - Seats**

green - 52,72 1 m - 39 3/8 in.  
 nut brown - 51,71 1 m - 39 3/8 in.  
 oxide red - 80,87 1 m - 39 3/8 in.  
 Oxford grey - 53,83 1 m - 39 3/8 in.  
 pampas green - 52,86 1 m - 39 3/8 in.  
 pigalle - 79 1 m - 39 3/8 in.  
 black - 80,92 1 m - 39 3/8 in.  
 light platinum - 50,78,90 1 m - 39 3/8 in.  
 light azure - 54 1 m - 39 3/8 in.  
 light Balearic beige - 81,93 1 m - 39 3/8 in.  
 dark khaki brown - 52 1 m - 39 3/8 in.  
 Indian red - 91 1 m - 39 3/8 in.

4 61 - 7 65 E 303  
 8 65 - 7 66 K 490 B  
 8 65 - TBE 000 002 634  
 8 65 - TBE 000 002 662  
 8 65 - TBE 000 002 672  
 8 65 - BBX 000 002 046  
 8 65 - BBX 000 002 634  
 8 65 - BBX 000 002 662  
 8 65 - BBX 000 002 672  
 8 65 - BBX 000 002 772

**Binding**

tin grey 1 m - 39 3/8 in.  
 scarlet - 79 1 m - 39 3/8 in.  
 ultra blue - 54 1 m - 39 3/8 in.  
 almond beige - 81,93 1 m - 39 3/8 in.  
 rust - 51 1 m - 39 3/8 in.  
 lava - 50,55,78,80,83,90,91,92 1 m - 39 3/8 in.  
 ultra blue - 54 1 m - 39 3/8 in.  
 almond beige - 81,93 1 m - 39 3/8 in.  
 rust - 51 1 m - 39 3/8 in.  
 dark brown - 52 1 m - 39 3/8 in.