

# Volkswagen Owner's Manual: Operation and Maintenance

---

Type 3

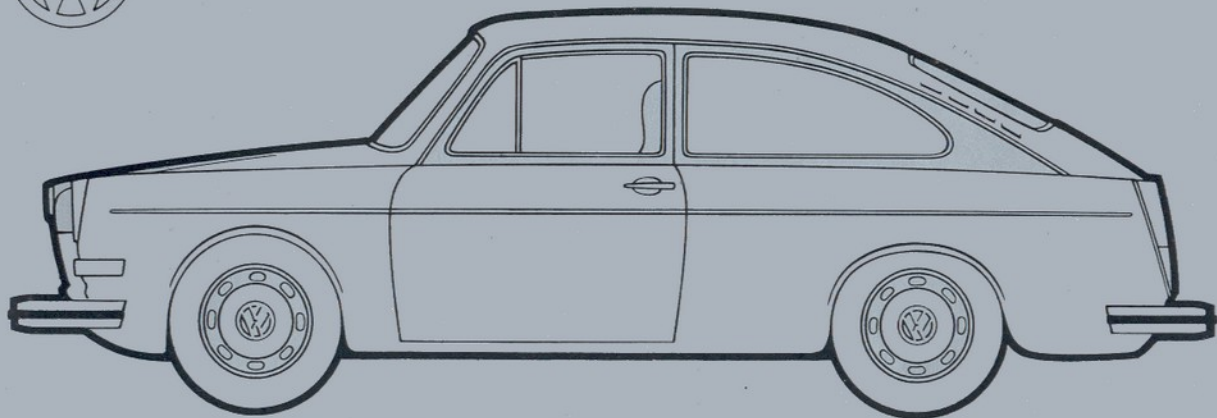

# Owner:

---

Last name

First name

Initial

---

Street

---

Town

State

Zip code

---

Area code

Tel. No.

# Volkswagen Owner's Manual: Operation and Maintenance

## 1972 Models



Volkswagen  
Type 3



Volkswagen  
Squareback Sedan

© 1971 VOLKSWAGENWERK AKTIENGESELLSCHAFT

All rights reserved. May not be reproduced or translated in whole or in part without the written consent of Volkswagenwerk AG.  
Specifications subject to alteration without notice.

563.002.23 · Printed in Germany · 8. 71

**The VOLKSWAGEN OWNER'S MANUAL consists of two major parts: operation description and Diagnosis & Maintenance record.**

**The first part acquaints you with your Volkswagen Warranty and the operation of your car. It also gives you information on fuel, oil, lubrication, plus technical data.**

**The second part deals with the maintenance of your Volkswagen. It explains what the VOLKSWAGEN DIAGNOSIS and MAINTENANCE is all about, and how to keep your Volkswagen in top driving condition.**

**Always have your Volkswagen Owner's Manual with you when you take your car to an Authorized Volkswagen Dealer for service . . . it provides your Service Adviser with the information he needs, and enables him to make the necessary entries for you.**

**Please read this manual before you drive your new Volkswagen. Acquaint yourself with its features, and know how to operate it more safely . . . because the more you know about it, the more you will enjoy driving your Volkswagen.**

Pictures and text in this manual are based on the 1972 Volkswagen Type 3 with Manual Transmission. Where the controls, equipment and technical data of the VW Squareback Sedan and the Automatic Transmission differ considerably, we will point this out in the text.

It has always been Volkswagen's policy to continuously make technical improvements; therefore, the right is reserved to make changes at any time during the model year without notice.

# Contents

	page		page		page
Warranty .....	7	Assist straps and coat hooks .....	39	Checking the engine oil level .....	83
Dear VW Owner .....	13	Ashtrays .....	39	Changing the engine oil .....	84
Vehicle identification .....	15	Glove compartment .....	40	Manual Transmission oil .....	85
Keys .....	16	Luggage compartments, Type 3 ..	40	Automatic Transmission Fluid .....	85
Doors .....	17	Engine compartment, Type 3 .....	42	Air cleaner .....	86
Windows .....	18	Luggage compartments,		Lubrication	
Seats (front) .....	18	Squareback .....	43	Front axle .....	88
Safety belts .....	20	Engine compartment,		Door hinges and locks .....	89
Instrument panel .....	22	Squareback .....	45	When trouble troubles you .....	90
Ignition/steering lock .....	24	Heater/Defroster .....	46	Engine oil .....	93
Fuel gauge .....	25	Ventilation .....	48	Transmission oil and ATF .....	94
Speedometer dial .....	25	Air conditioner .....	50	Technical data	
Clock .....	25	Auxiliary heater .....	52	Engine .....	96
Turn signal/headlight dimmer		Trailer hauling .....	53	Transmissions .....	97
switch lever .....	26	Towing .....	54	Chassis (general specifications)	98
Lane changer .....	26	Winter operation .....	55	Sectional side view of the car:	
Windshield wiper/washer lever ..	26	Tires .....	57	attached to page .....	98
Oil pressure warning light .....	27	Spare wheel .....	61	Electrical system .....	99
Generator warning light .....	27	Jack .....	62	Dimensions and weights .....	99
Emergency flasher .....	28	Changing a wheel .....	63	Capacities .....	100
Headlight switch .....	28	Container for windshield washer		Performance .....	100
Instrument illumination .....	28	fluid .....	69	Volkswagen Diagnosis and	
Brake warning light .....	29	Brake fluid reservoir .....	69	Maintenance .....	103
Rear window defogger .....	30	Fuses .....	70	Test report .....	104
Rear view mirrors .....	31	Battery .....	72	Maintenance record .....	107
Manual Transmission .....	32	Fuel supply .....	73	Additional service .....	117
Automatic Transmission .....	34	Cleaning your VW .....	74	Scheduled maintenance .....	118
Starting hints .....	37	Removing and installing seats ...	77	Address change cards .....	122
Sun visors .....	38	Bulb chart .....	78	Index .....	127
Sliding roof .....	38	Replacing bulbs .....	78	VW Distributor addresses .....	130
Interior light .....	39	Cleaning and replacing spark			
		plugs .....	82		

Volkswagen offers a quality product. Maintain this quality by having your Volkswagen serviced regularly. A service schedule that we recommend is explained in the section Volkswagen Diagnosis and Maintenance.

Should you have occasion to make use of your Volkswagen Warranty, it is always helpful to have the related service receipts handy.



# WARRANTY VOUCHER

for the new VW automobile

Type: \_\_\_\_\_

Chassis No. \_\_\_\_\_

Engine No. \_\_\_\_\_

In accordance with the **terms of warranty** printed overleaf.

The warranty commences at the date the VW automobile is delivered to the original purchaser,

viz. on \_\_\_\_\_  
(To be filled in by selling VW Dealer)

and covers a period of 24 months or the period before the vehicle has been driven 24,000 miles, whichever event shall first occur. Should any warranty claim arise, you are requested to present this voucher to your VW Dealer.

**VOLKSWAGEN OF AMERICA, INC.**

(Stamp of Selling  
VW Dealer)



## Air Conditioner Installation

Date \_\_\_\_\_

At Mileage \_\_\_\_\_

Make, Model \_\_\_\_\_

(Stamp of Installing  
VW Dealer)

## Auxiliary Heater Installation

Date \_\_\_\_\_

At Mileage \_\_\_\_\_

Make, Model \_\_\_\_\_

(Stamp of Installing  
VW Dealer)

## Speedometer Replacement

Date \_\_\_\_\_

A. Mileage \_\_\_\_\_

Make, Model \_\_\_\_\_

(Stamp of Replacing  
VW Dealer)

No express warranties as to Volkswagen vehicles sold in the United States are made either by Volkswagen of America, Inc. ("VWoA"), or by the manufacturer, the distributor or the selling dealer, except the following warranty by Volkswagen of America, Inc.

### **Warranty for New Volkswagen Vehicles**

This warranty is issued by Volkswagen of America, Inc. ("VWoA"), the authorized United States importer of Volkswagen vehicles.

**Free repair or replacement in the United States and Canada of defective parts for 24 months or 24,000 miles**

1. VWoA warrants that every Volkswagen vehicle imported by VWoA and sold as a new vehicle to a retail customer by an authorized United States Volkswagen dealer will be free from defects in material and workmanship under normal use and service for 24 months after the date of delivery of the vehicle to the original retail customer or until the vehicle has been driven 24,000 miles, whichever comes first. This warranty is limited, however, to the following: If any part of the vehicle becomes defective under normal use and service and the vehicle is brought during this period to the workshop of any Authorized Volkswagen Dealer in the continental United States, Hawaii or Canada, the dealer will, without charge, either repair the defective part or replace it with a new or factory reconditioned part.

**Maintenance required to keep warranty in effect**

2. In order to keep this warranty in effect, the owner must have the vehicle maintained and serviced as prescribed in the Volkswagen Maintenance Schedule.

**Items not covered by warranty**

**3. VWoA's warranty does not cover:**

(i) Defects, damage or deterioration due to normal use, wear and tear or exposure; (ii) normal maintenance services, such as fuel system cleaning and wheel, brake or clutch adjustments; (iii) the replacement of service items, as, for instance, spark plugs, ignition points, wiper blades or brake linings; (iv) deterioration of upholstery, soft trim and appearance items; (v) damage or defects due to misuse, alteration, negligence or accident; (vi) damage or defects due to the repair of the vehicle by someone other than an Authorized Volkswagen Dealer or the installation of parts other than genuine Volkswagen parts; (vii) damage or defects due to the use of the vehicle in competitive events, including rallies and races; and (viii) loss of time, inconvenience, loss of use of the vehicle or other consequential damage.

**Warranty outside the United States and Canada**

4. If the vehicle is brought to an authorized Volkswagen workshop outside the continental United States, Hawaii or Canada, VWoA's warranty will not be applicable and defective parts will be repaired or replaced free of charge with new or factory reconditioned parts only within the terms and limitations of the warranty for new Volkswagen vehicles in effect in the country where such authorized Volkswagen workshop is located.

**No other warranties made**

5. This warranty is in lieu of all other express warranties of VWoA, the manufacturer, the distributor and the selling dealer. Neither VWoA nor the manufacturer assumes, or authorizes any person to assume, on its behalf, any other obligation or liability.

## Let us explain the warranty...

Volkswagen of America, Inc. is proud of the quality of the automobiles it imports. It warrants new vehicles for a period of 2 years or 24,000 miles from the date of purchase, whichever comes first. In general, the complete vehicle including battery and tires is covered under the provisions of the Volkswagen New Vehicle Warranty. It will be honored by any Authorized Volkswagen Dealer in all 50 States, the District of Columbia and Canada.

This warranty is transferable if the ownership of the vehicle changes within the above period.

In order to keep the warranty in force, you, as the owner of the vehicle, have certain responsibilities. It is important that the vehicle be maintained properly. To facilitate record keeping, this booklet provides space for listing diagnosis, maintenance, and oil change services as they are performed.

Diagnosis and maintenance services should be performed by Authorized Volkswagen Dealers. They have Volkswagen-trained mechanics and special tools to provide fast, efficient service in accordance with Volkswagen quality standards.

The terms of your warranty require you to keep a maintenance record of your vehicle. Provided that maintenance or oil change services were performed in accordance with Volkswagen specifications, dated bills of other than Authorized Volkswagen Dealers will be accepted as proof that these services were performed when required.

Not all repairs, adjustments and replacements, however, are the result of defects in material or workmanship. There are other circumstances beyond the control of the manufacturer that might make a workshop visit necessary. These depend mainly on where you drive and how you drive. They would include weather and atmospheric conditions, varying road surfaces, individual driving habits and vehicle usage.

**For example, you are required to pay for the following:**

### **Maintenance services and oil changes.**

**Diagnosis services** — except those diagnosis services for which a free coupon is presented at specified mileage intervals.

**Wheel alignment and wheel balancing.** The frequency of these services depends on driving conditions such as rapid starts and stops, tire skidding, hitting pot holes and curbs, etc.

**Mechanical adjustments** — including brakes, clutch, door locks — are required as a matter of normal operation of a motor vehicle. This protects you against early or expensive replacements.

**Brakes and clutch linings** are directly affected by driving habits and use. The replacement of brake linings, brake pads, clutch linings and shock absorbers, and the reconditioning of brake drums and brake discs should be performed whenever necessary.

**Spark plugs and ignition points** are subject to wear. Periodic replacements ensure you of maximum engine performance and gasoline economy.

**Wiper blades** will have a varied life expectancy, depending on climatic conditions and extent of use. You are the best judge of when they should be replaced.

**Light bulbs and fuses are service items.**

**Paint, chrome, trim and other appearance items** are affected by normal wear and exposure. Proper care of these items can add to their appearance and durability. (Imperfections are normally apparent during New Vehicle Pre-Delivery Inspection. For your protection, please report any imperfection to your dealer immediately.)

**Tires and battery** are subject to wear. If there is a defect, you pay only for the amount of use you obtained. An adjustment for tires is based on the remaining tread depth. Battery adjustment is according to time used, based on 24 months of service. This is known as the pro-rata method of adjustment.



Volkswagen parts, accessories and exchange units are identified by these trademarks.

All meet the same exacting quality control standards as the original equipment on the car, and comply with all applicable Government safety regulations.

They are guaranteed to be free from defects in material or workmanship for a period of 6 months or 6,000 miles, whichever comes first.

All Volkswagen Parts and accessories are available at your Authorized Volkswagen Dealer.

Also, ask him about rebuilt parts under the Volkswagen Exchange Service . . . they cost less than new parts but carry the same warranty.

## Dear VW Owner

A lot has gone into the manufacture of your Volkswagen. Including advanced engineering techniques, rigid quality control and demanding inspections. The engineering and safety features that have gone into your VW will be enhanced by . . . you, the safe driver

- who knows his vehicle and all the controls,
- who maintains his vehicle properly,
- who uses his driving skills wisely.

Because safe driving is important to you, we urge you to read this manual carefully, to maintain your VW properly and to follow the check list shown on this page whenever you use your VW.

### Before getting behind the wheel:

- 1 – Make shure that the tires are inflated correctly.
- 2 – Watch the tread depth indicator on the tires. Look for bruises and wear.
- 3 – See that all windows are clean and unobstructed.
- 4 – Check that headlight and tail light lenses are clean.
- 5 – Check that all lights are functioning properly.
- 6 – Check turn signal lamps and indicator lights (ignition on).

### In the driver's seat:

- 1 – Position seat properly for easy reach of controls.
- 2 – Adjust inside and outside mirrors for unobstructed rear view.
- 3 – Fasten safety belts.
- 4 – Check brake warning light (ignition on).
- 5 – Check brake operation.
- 6 – Make sure that all doors are closed securely and locked.

### And when you are on the highway:

- 1 – Always drive defensively. Expect the unexpected.
- 2 – Use signals to indicate turns and lane changes.
- 3 – Turn on headlights at dusk.
- 4 – Follow at a safe distance. A good rule of thumb is to allow a minimum of one car length for each 10 mph of speed.
- 5 – Reduce speed during night hours and inclement weather.
- 6 – Observe speed limits and obey highway signs.
- 7 – When tired, get off the highway, stop and take a rest.
- 8 – When stopped or parked, always set the parking brake.
- 9 – When stalled or stopped for repairs, move the car well off the road. Set the emergency flasher and use road flares or other warning devices to warn other motorists.

MANUFACTURED BY **VOLKSWAGENWERK AG**

THIS VEHICLE CONFORMS TO ALL APPLICABLE FEDERAL MOTOR  
VEHICLE SAFETY STANDARDS IN EFFECT ON THE DATE OF MANU-  
FACTURE SHOWN ABOVE

08/71



This sticker is your assurance that your 1972 Volkswagen complies with all U. S. Federal Motor Vehicle Safety Standards which were in effect at the time the vehicle was manufactured. You can find this sticker on the left doorjamb. The sticker also shows the month and year of production as well as the chassis number of your car (perforation).



## Vehicle Identification

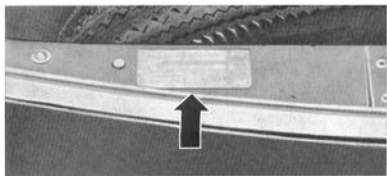

### The identification plate

is the "birth certificate" of your Volkswagen. It is located under the front hood beside the hood lock.

The plate shows such information as manufacturer's name, place of origin, model, weights and "Fahrgest.-Nr.", which is the chassis number of your car.



### The chassis number

is also located on the instrument panel on the driver's side so that it is visible from the outside through the windshield. This is for your protection . . . . to aid in the apprehension of car thieves and the recovery of stolen vehicles.

The chassis number is also stamped on the frame tunnel under the rear seat.

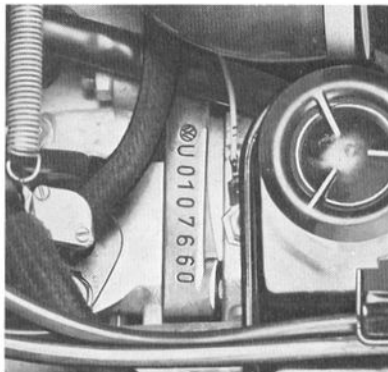

### The engine number

is stamped on the crankcase housing between the ignition distributor and the engine oil breather.

## Keys



Your Volkswagen comes with two sets of keys:

**The key with the elongated head** is for the doors and the ignition/steering lock. On the VW Squareback Sedan, it is also for the rear luggage compartment lid.



**The key with the round head** is for the glove compartment only.

### **Do not invite car theft**

by leaving your car unattended with the key in the ignition lock. Take the key with you and lock the doors. A buzzer will remind you when you open the driver's door and the key is still in the ignition lock.

It is a good idea to keep a record of your key numbers in your wallet together with your license. If you should lose a key, your Authorized VW Dealer will thus be able to quickly secure a replacement key for you.

## Doors

**Always drive with locked doors to prevent inadvertent opening of a door from the inside, especially with smaller children in the car.**

Since your Volkswagen is almost air tight it will be easier to close the door if you open a window slightly.

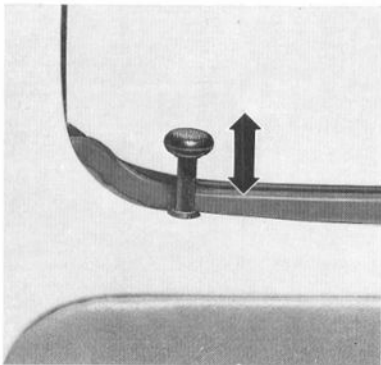

### **To lock and unlock doors from the outside**

You can lock and unlock your car with a key, of course.

But you can also lock it without a key. First push in the inside locking knob on the upper door panel. Then depress the plunger in the outside door handle as you close the door.

### **To lock and unlock doors from the inside –**

depress or pull out the locking knob.

If the door, with the locking knob depressed, closes by itself, the locking device will disengage automatically. We provided this additional feature so you won't be locked out if the door should slam shut while the key is still inside the car.

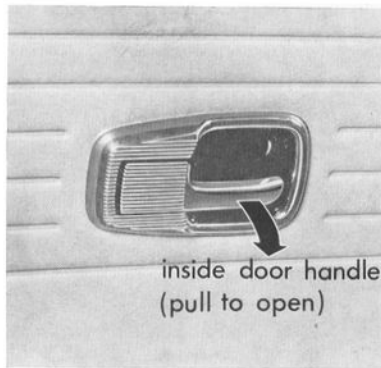

## Windows

We recommend you do not put decals or other signs on the windows of your car that interfere with the driver's vision.

We have made the windshield and windows large for clear, unobstructed visibility.

You can lower and raise the windows in the front doors by means of winders. We cushioned the knobs for your safety.

To open the vent window, turn knob into driving direction, move locking lever forward and push out window.

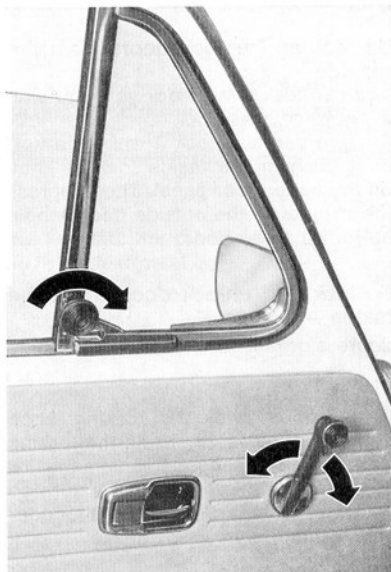

## Seats

We recommend you do not adjust the driver's seat while driving. Your seat may suddenly jerk forward or backward, which could result in loss of control.

Your Volkswagen has adjustable front seats with built-in headrests.

To move the seat forward and backward, pull the lever on the outboard side of the seat. Now slide the seat to the desired position. Let the lever go, and move the seat slightly back and forth to make sure it is securely engaged.



You can adjust the backrest to eight different angles. Push the backrest slightly forward to take the weight off; then turn the large knob on the outboard side of the seat.



We have installed a lock on the side of the backrest.

You can disengage this lock by pulling up the lever. Tilt the backrest forward and out of the way for easy access to the rear passenger compartment.

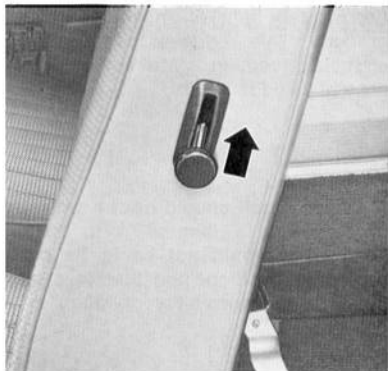

## Safety belts

A safety belt is provided for each seating position in your Volkswagen. For your protection, **fasten your safety belt before driving off and wear it at all times while the car is in motion.**

Store safety belts of unoccupied seats properly. This reduces the possibility of their becoming a striking object in case of a sudden stop.

**A shoulder belt should not be worn by a person less than 4'7" in height because it would not be in its most protective position, and therefore may increase the possibility of injury in a collision.**

**Do not strap in more than one person in each belt.**

### Safety belts for front seats

The **front seats** are equipped with **combination lap/shoulder belts**. For easy storage a hook is provided on the door post.

**To fasten** your combination lap/shoulder belt, grasp the belt tongue, take it off the hook on the door post and pull the belt across your chest and lap. Insert the belt into the anchor housing on the center tunnel and press until it is **securely locked**.

**Belts should not be worn loose or twisted.** They should fit snugly across your body. The lap belt section should be completely unrolled from the retractor.

**To adjust** the length of the belts, press in the release on the buckle (arrow) as you pull the respective belt section in the desired direction. With this release it is also possible to adjust the belt length with the buckle already engaged in the anchor housing. Take up any slack of the loose belt by moving the slide on the belt.

**To release** the belt, pull the lever with the white top on the anchor housing upward.

**When not in use the belt should be hung** on the hook provided for this purpose on the door post.



### **Safety belts for rear seats**

**The rear seats are equipped** with adjustable lap belts. Pull the longer section across your lap and insert the tongue in the inboard buckle. Press until you hear a click to be sure the belt is locked securely. **The belt should not be worn loose or twisted.**

To **release** the belt, pull the lever (white top) on the buckle.

To **lengthen** or **shorten** the rear belt, hold the belt tongue at a right angle to the belt and pull the respective belt section in the desired direction. Take up any slack of the loose belt end by moving the slide on the belt.

Keep safety belts clean. If cleaning is necessary, wash them with a mild soap solution, without removing them from the car.

Do not bleach or dye safety belts. Do not use any other cleaning agents. They may weaken the webbing.

Check buckles and retractors for proper function. Check belt webbing and bindings for damage.



**The belts should always be kept on top of the seat for ready use. Do not permit them to get caught under the seat.**

## Instrument panel

The padded instrument panel and steering wheel are attractively styled for maximum safety and driving ease.

The various controls, gauges and warning lights are conveniently arranged and marked with readily recognizable symbols.

A padded assisthandle above the glove compartment lid is provided for easier passenger entrance and exit.

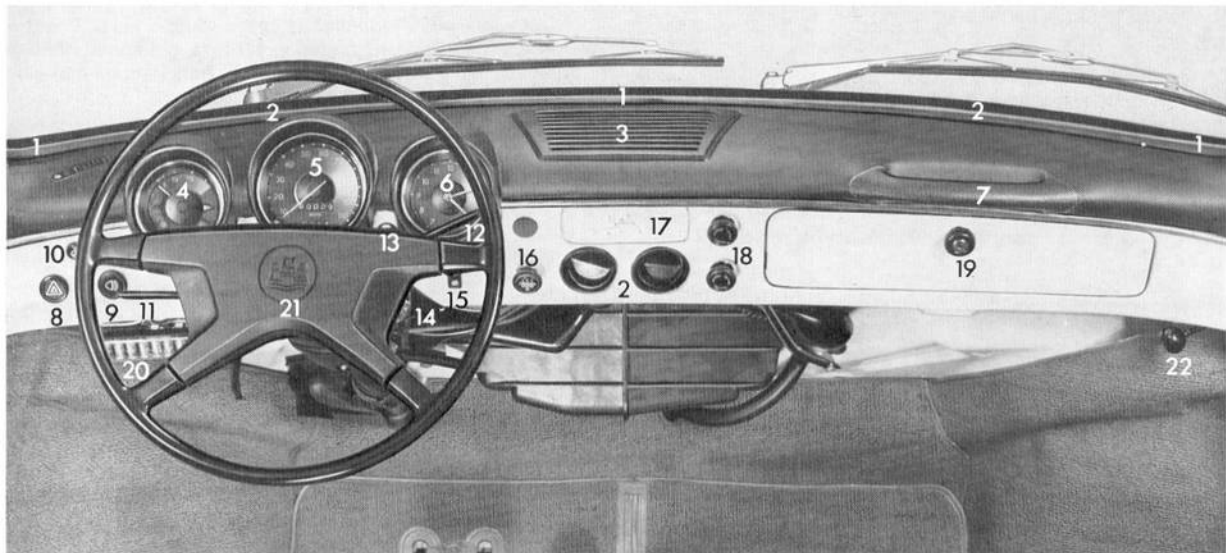



	Page
1 – Vents for heating and defrosting (there are 3) .....	46
2 – Vents for fresh air ventilation (there are 2 on the windshield and 2 on the dashboard) .....	48
3 – Loudspeaker grille .....	
4 – Fuel gauge with warning lights .....	25
5 – Speedometer dial .....	25
6 – Clock .....	25
7 – Assishandle .....	
8 – Emergency flasher switch .....	28
9 – Headlight switch .....	28
10 – Knob for fresh air fan .....	49
11 – Turn signal and headlight dimmer switch lever .....	26
12 – Windshield wiper/washer lever .....	26
13 – Brake warning light .....	29
14 – Ignition/steering lock .....	24
15 – Switch for rear window defogger .....	30
16 – Control knob for Auxiliary Heater (optional equipment) .....	52
17 – Ashtray .....	39
18 – Fresh air control knobs (there are 2) .....	48
19 – Glove compartment, lockable .....	40
20 – Fuse box .....	70
21 – Horn .....	
22 – Release for fuel tank flap .....	73

## Ignition/steering lock

The steering is equipped with an anti-theft ignition lock.

### Fasten safety belts.

**Make sure the gearshift lever is in Neutral before turning the ignition key. The Automatic Transmission can be started in Neutral or Park (see also pages 36 and 90).**

- 1 – Ignition off/steering locked.  
Insert the key. If it is difficult to turn the key, gently move the steering wheel until the key turns freely.
- 2 – Ignition on/steering free (for towing).
- 3 – Starter engages.  
The key returns to position 2 as soon as it is released. Never operate the starter longer than a few seconds. If the engine should fail to start, turn the key back to position 1, and repeat the starting procedure. More on starting on page 37.

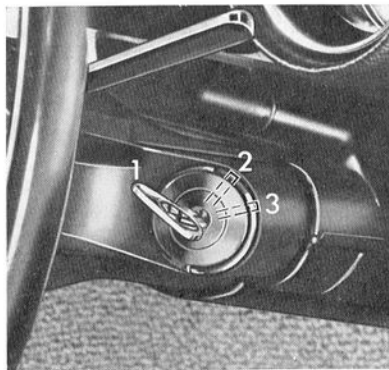

To remove the key and to lock the steering, turn the key back to position 1 and pull it out. Turn the steering wheel until it locks.

**The steering column will lock when you remove the key. Therefore do not remove the key while you are driving or as the car is rolling to a stop.**





If you leave the key in the ignition/steering lock, the buzzer will sound when the driver's door is opened. This is your reminder to remove the key.

## Fuel gauge

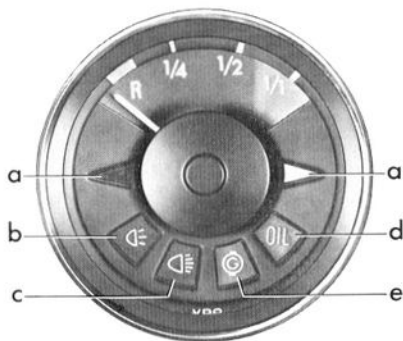
It only indicates the fuel level when the ignition is turned on. When the needle is on "R", there is a reserve of about 1 gallon of fuel left in the tank . . . time to refuel at the next gas station.

**The following indicator or warning lights** are in the fuel gauge dial:



- a – green  turn signals
- b – green  parking light
- c – blue  high beam
- d – red **OIL** oil pressure
- e – red  generator

## Speedometer

The speedometer indicates the speed. The 5-digit odometer records the miles driven. The 4-digit trip odometer can be reset to zero by turning the knob to the right to record a driven distance. The last digit in red indicates 1/10 of a mile.



## Clock

The clock is electric. To set the clock, depress the knob in the dial center and turn.

### Turn signal/headlight dimmer switch lever and windshield wiper/washer lever

There are two levers just behind the steering wheel:

The lever on the left side is for the turn signal/headlight dimmer switch.

The lever on the right side is for the windshield wiper/washer system.

The turn signals and the windshield wipers only work with the ignition on.

### Turn signals

Lever up — right turn signal

Lever down — left turn signal

The green turn signal indicator lights come on in the fuel gauge dial when you operate the lever.

The turn signals are cancelled automatically when you have completed a turn (like driving around a corner), and the steering wheel returns to the straight-ahead position.

If a turn signal is defective, the control lights flash at about twice the normal frequency. Have your Authorized VW Dealer check and repair it for you.

### Lane changer

To indicate your intention when changing lanes on expressways, slightly lift or depress the lever to an intermediate position. The lever will return to the OFF position when released.

### Headlight dimmer

Dim the headlights by pulling the lever toward the steering wheel. The blue indicator light in the fuel gauge dial will light up when the high beams are on.



## Windshield wipers

The windshield wiping system operates at two speeds: low and high.

Lifting lever to first stop — low speed  
Lifting lever to second stop — high speed

If you just slightly lift the lever before reaching the first stop, the wipers will wipe as long as the lever is held in this position and come to a stop when released.

To give you full battery power while starting the engine, operating windshield wipers will stop automatically at this moment.

## Windshield washer

To spray washer fluid on the windshield, pull the lever toward the steering wheel. You can operate the washer from any selected wiping position.

Avoid running the wiper blades on a dry windshield . . . you may scratch the glass. Spray washer fluid on it first.

The **red warning lights for oil pressure and generator** in the fuel gauge dial will light up when the ignition is turned on. They should go out after you have started the engine.

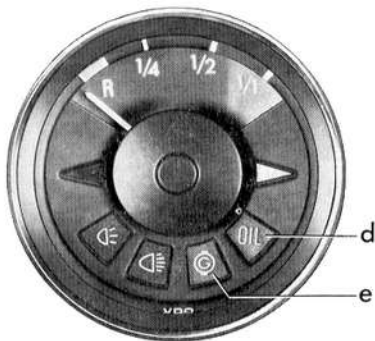

Whenever stalled or stopped for repair, move the car well off the road. Turn on the emergency flasher and mark the car with road flares or other warning devices. Before working on any part in the engine compartment, wait until the engine has sufficiently cooled down.

## d — Oil pressure warning light

**Stop at once . . .**

if the oil pressure warning light comes on while you are driving.

Check the oil level to make sure you have enough oil. If the cause is somewhere else, do not drive on but contact your nearest Authorized VW Dealer.

An occasional flickering of the oil pressure warning light when the engine is idling after a long high-speed trip is no cause for concern if the light goes out upon acceleration.

## e — Generator warning light

If this light comes on when you are driving, the generator has stopped charging. You can drive on. But try to get the vehicle to your dealer as soon as possible because the battery will soon run down.

**Move the car well of the roadway when stalled or stopped for repairs. Do not remain in the car.**

### **Emergency flasher switch**

If your car is disabled or parked under emergency conditions, pull the switch to make all four turn signals flash simultaneously. The warning light in the switch knob flashes, too.

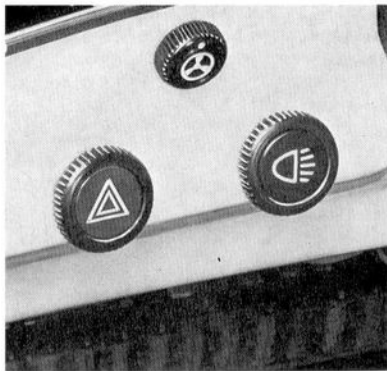

### **Headlight switch**

Pull the knob to the first stop to turn on the parking lights, the side marker lights, the license plate, tail and instrument lights . . . and, on cars with Automatic Transmission, the light for the selector lever console.

The green indicator light — b — in the fuel gauge dial lights up. It is your reminder that the parking lights are on. It will go out as soon as you pull the knob to the second stop to turn on the headlights. The headlights only work with the ignition on.

To preserve the battery, the headlights will go out automatically when the ignition is turned off or when the engine is started.

### **Instrument illumination**

You can adjust the brightness of the instrument lights by turning the knob.

## Brake warning light

Your Volkswagen is equipped with a dual circuit brake system. Both circuits, one for the front brakes and one for the rear brakes, can function independently.

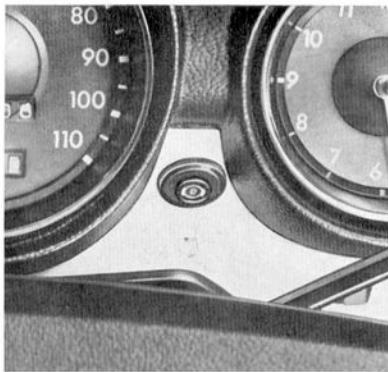

If the brake warning light lights up when you apply the brakes while driving, one of the two brake circuits may have failed.

The other brake circuit will still operate, but a longer distance and greater pedal pressure are required to bring the car to a halt.

Pull off the road and stop.

Try out the effectiveness of the brakes by carefully starting and stopping on the road shoulder.

If you judge that the brakes operate safely enough to take you to the nearest dealer, proceed cautiously and at low speed. If you do not feel safe to continue, have your car towed to the nearest dealer for repair.

## Proper functioning of brake warning light

The brake warning light will light up when the ignition is turned on. It will go out after the engine has been started. This is your assurance that the brake warning system functions properly.

If the brake warning light does not light up when turning on the ignition, or if it does not go out after starting, there may be a defect in the electrical system. If this is the case, contact your Authorized VW Dealer.

## Rear window defogger

The rear window defogger – together with the flow through ventilation – will help to keep the inside of the rear window clear of condensation and frost in the winter.

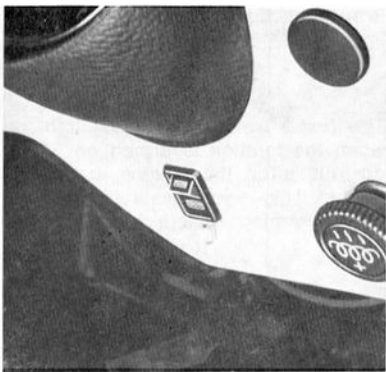

The rocker switch for the rear window defogger is located on the right side of the steering column. A red dot on the rocker switch will appear when the defogger is switched on.

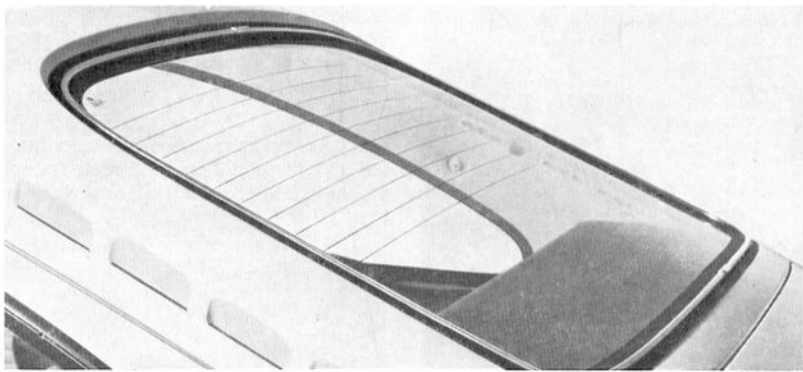

After the rear window defogger has been cleared, switch off the rear window defogger to avoid an unnecessary drain on the battery.

**The filler panel between the rear seat and the rear window should not be used for storage, even for small and light items. During sudden stops, these articles may cause injury when dislodged. Larger items may reduce vision to the rear.**



## Rear view mirrors

Adjust the outside and inside mirrors before driving off. It is important for safe driving that you have good vision to the rear.

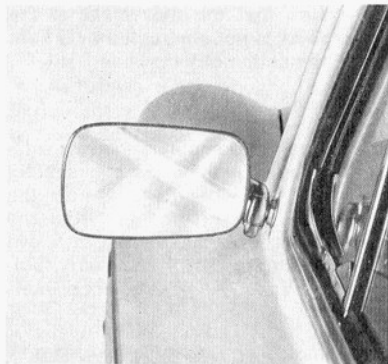

### Outside mirror

The outside mirror is hinged and folds flat against the car when struck from either direction.

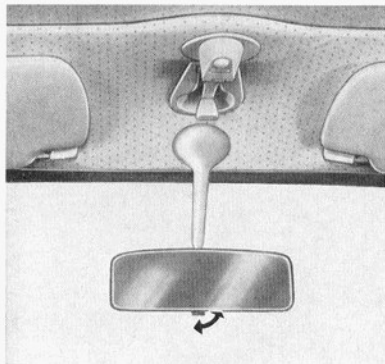

### Inside day-night mirror

You can move the day-night mirror from clear daylight visibility to non-glare visibility at night by adjusting the lever upward or downward at the bottom of the mirror.

# Controls for Manual Transmission

## 1 – Clutch pedal

Always depress the clutch pedal fully when changing gears. Do not hold the car on a steep hill with the clutch pedal partially depressed. This may cause premature wear or damage.

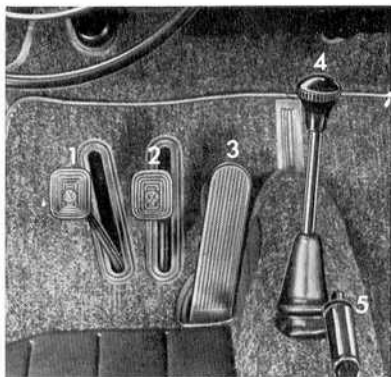

## 2 – Brake pedal

Make it a habit to check the operation of your brakes. You will remember from page 29 that the brake warning light will alert you if one brake circuit may have failed.

**Make sure that the movement of the brake pedal is not obstructed by a floor mat, or any other object.**

Volkswagen automobiles have excellent brakes, but they are still subject to wear . . . depending on how the brakes are used. If you find that the brake pedal travel has increased, have the brakes adjusted; if necessary, between the specified maintenance intervals.

Keep in mind that the braking distance increases very rapidly as the speed increases. At 60 mph, for example, it is not twice but four times longer than at 30 mph. Tire traction is also less effective when the roads are wet and slippery. Therefore, always maintain safe distance.

Driving through deep water may reduce the tire traction. Moisture on the brakes may also affect braking efficiency. Cautiously apply the brakes for a test. If you notice a lag in the braking action, the brakes may be wet. They will dry after you have applied the brakes a few times, but do it very cautiously.

Brake linings may not have the highest possible braking efficiency when new. Therefore allow for longer braking distance during the initial 100 to 150 miles. This also applies when brake shoes are renewed.

## 3 – Accelerator pedal

For good fuel economy we recommend smooth and even acceleration. Very fast, racy driving, alternating between full throttle and hard braking, raises the fuel consumption considerably. Also, tires and brake linings wear faster. It is more economical to drive smoothly and at a fairly constant speed.

You can drive most economically between:

- 10 and 20 mph in 2nd gear
- 20 and 35 mph in 3rd gear
- 30 and 60 mph in 4th gear

#### 4 — Gearshift lever

Your Volkswagen has a fully synchronized transmission. The four forward gears and a reverse gear are arranged as illustrated. The shift pattern is also shown on the face of the ashtray in the dashboard.

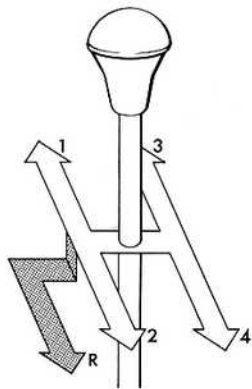

**Resting your hand on the shift lever knob while driving will cause premature wear to the transmission.**

#### Speed ranges

You can drive your Volkswagen at full speed from the first day. You do not have a break-in schedule. There are, however, certain recommended speed ranges for the various gears:

1st gear	0 — 15 mph
2nd gear	10 — 35 mph
3rd gear	20 — 55 mph
4th gear	30 mph and up

If you have a traffic situation where it is necessary for you to overtake rapidly, you can accelerate, for a brief period only, up to

43 mph in 2nd gear
60 mph in 3rd gear

#### Reverse

Only shift into Reverse when the car is not moving. To engage the reverse gear, press the lever down, move it to the left and pull back.

The back-up lights go on automatically when you engage the reverse gear (with the ignition on).

#### 5 — Parking brake lever

**Do not remove the key from the steering lock while the car is rolling to a stop. The steering column is locked as soon as you remove the key. Take out the key only after the car is parked.**

To set the parking brake, press in the release button at the end of the lever as you pull up the lever. The parking brake is engaged as soon as you release the button on the raised lever.

To release the parking brake, pull the lever slightly up as you depress the release button. Then push the lever all the way down.

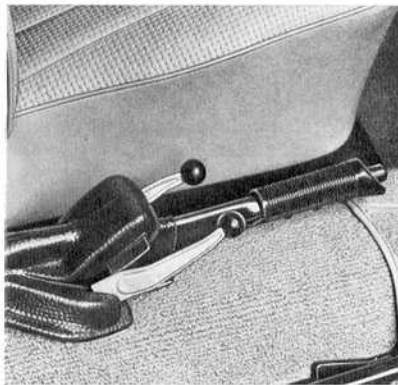

Be sure it is fully released. A partially engaged parking brake promotes wear of the brake lining.

Always set the parking brake when parking your car. On steep hills also turn the wheels toward the curb.

# VW Automatic Transmission

There are few points you should know if you want to take full advantage of your Automatic Transmission.

**The selector lever** has 6 positions:

- P = Park
- R = Reverse
- N = Neutral
- D = Drive
- 2 = } Lower driving ranges
- 1 = }

From N to R: lift lever and push forward

From R to P: lift lever and push forward

From P to R: lift lever and pull back

From R to N: just pull lever back

**Remember the following basic rules:**

- Apply the parking brake or foot brake before selecting a driving range. When the selector lever is in a driving range, the car may creep even at an idling speed. Therefore, do not release the parking brake or foot brake until you are ready to move.
- Do not accelerate while selecting a driving range. At this time the engine must run at idling speed so that no undue stress will be placed on the automatic clutches in the transmission.
- If the selector lever is accidentally moved into Neutral (N) while driving, take your foot off the accelerator pedal and wait until the engine speed has dropped to idling before selecting a driving range.

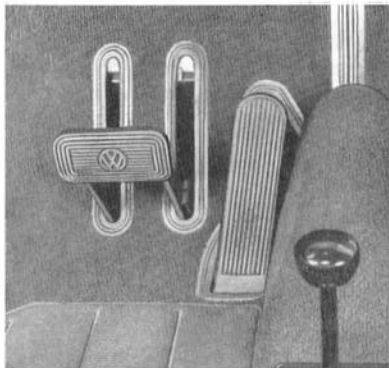

It is easy to move the selector lever between Neutral and the forward driving ranges Drive, 2 and 1. When engaging Reverse or Park and moving the lever back into Neutral, observe the following:

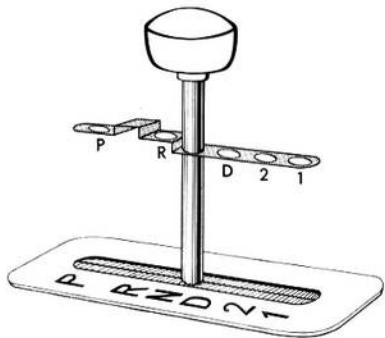

The selector lever console is illuminated when the parking or headlights are switched on.

## The driving ranges

The Automatic Transmission has 3 forward driving ranges and one reverse. In the selected driving ranges, the Automatic Transmission changes gears automatically while driving.

### Position D

is the driving range to be normally used for day-to-day driving and highway driving. It ranges from zero to top speed, and all three gears engage automatically while driving.

### Positions 2 and 1

are to be used for mountain driving or slow driving, and also when you want to make use of the engine's braking effect.

### Position 2

should only be used up to 60 mph. In "2", only the first and second gears will engage automatically. Therefore, only shift down into driving range "2" when the car speed is below 60 mph. It is not necessary to let up on the accelerator.

### Position 1

is needed on rare occasions. It should only be used up to 40 mph. In "1" the transmission will stay in first gear and not shift into the second or third gear. Therefore, only shift down into "1" when the car speed is below 40 mph.

### The reverse driving range

should be selected only when the vehicle is stationary and without depressing the accelerator. To select reverse you must lift the lever slightly.

### Accelerator "Kickdown"

If you need quick acceleration to pass moving vehicles or to climb steep grades, make use of the accelerator "kickdown" in your VW with Automatic Transmission.

It gives you the possibility to shift into a lower gear without moving the selector lever. The accelerator kickdown can only be applied with the selector lever in the driving ranges D and "2".

When depressing the accelerator pedal you will find resistance at the full throttle position. By applying greater pressure the pedal can be pushed beyond this point to the kickdown position. The transmission will now shift automatically into the next lower gear to give you maximum acceleration, and only shift up again after the engine has reached maximum speed in that particular gear.

**Be careful when using the kickdown on icy roads. Rapid acceleration may cause skidding.**

Please observe the following when applying the accelerator kickdown:

With the selector lever in D, you can apply the kickdown to make the transmission shift down into second gear when driving below 55 mph and down to first gear when driving below 35 mph.

With the selector lever in "2", you can apply the kickdown to make the transmission shift down into first gear when driving below 35 mph.

As soon as you release the pedal from the kickdown position the next higher gear is automatically engaged.

### Starting the engine

is only possible when the selector lever is in Neutral or Park. As long as one of the driving ranges is engaged a safety switch prevents the engine from being started. For further details on starting see pages 24 and 37.

### Moving off

With the parking brake or foot brake set, shift into the range you wish to use, usually position D. To move off, release the brake and accelerate.

Do not release the brake before you are prepared to move, because power is transmitted to the wheels as soon as a driving range is engaged.

### Selecting a driving range

is easy. Simply release the accelerator pedal and move the selector lever from the range you are in to the range you want. Then step on the accelerator again.

### Stopping

When stopping temporarily, at traffic lights for example, it is not necessary to move the selector lever to Neutral. Simply apply one of the brakes. To start off again release the brake and accelerate.

### Maneuvering

When alternating between forward and reverse drive – for instance, while maneuvering the car into a tight parking space – only shift into Reverse or Drive when

- the car has come to a full stop,
- and the engine is running at idling speed.

### Mountain driving

When driving on long, steep and winding mountain roads select range 2 or 1.

### Parking

**Do not remove the key from the ignition steering lock until you have parked the car, because removal of the key locks the steering.**

When parking your car, apply the parking brake and move the selector lever to position P. To do this, move the lever through Reverse and lift it to the Park Position. The transmission is then mechanically locked.

The Park position may only be engaged when the car is stationary.

### Emergency starting

Your Volkswagen with Automatic Transmission **cannot be started by pushing or towing**. Should the engine fail to start consult your nearest Authorized Volkswagen Dealer.

## Starting hints

### Fasten safety belts!



Before turning the ignition key, make sure the gearshift lever is in Neutral.

The Automatic Transmission can only be started in Neutral or in Park.

Always fully depress the accelerator pedal first, and keep it depressed while operating the starter. This holds true for a cold engine and an engine at operating temperature no matter what the outside temperature is. The electronic fuel injection system, with which your Volkswagen is equipped, automatically supplies the right amount of fuel that is required for starting.

Operate the starter for a few seconds only.

As soon as the engine starts, release the ignition key.

If the engine does not start the first time or stalls, turn the ignition key all the way to the left and restart.

It is not necessary to warm up the engine by letting it idle with the car stationary . . . drive off immediately and maintain moderate speed until the engine is warm.

### Winter starting of Manual Transmission

On the Manual Transmission, also depress the clutch pedal when starting so that the starter only has to crank the engine.

**Never start or let the engine run in an enclosed, unventilated area. Exhaust fumes from the engine contain carbon monoxide, which is colorless and odorless. Carbon monoxide, however, is a very harmful gas, and may be fatal when inhaled.**

## Sun visors

You can lift the visors out of the center mounting and move them towards the door windows to prevent glare from the sides.

A vanity mirror is on the back of the sun visor on the passenger's side.

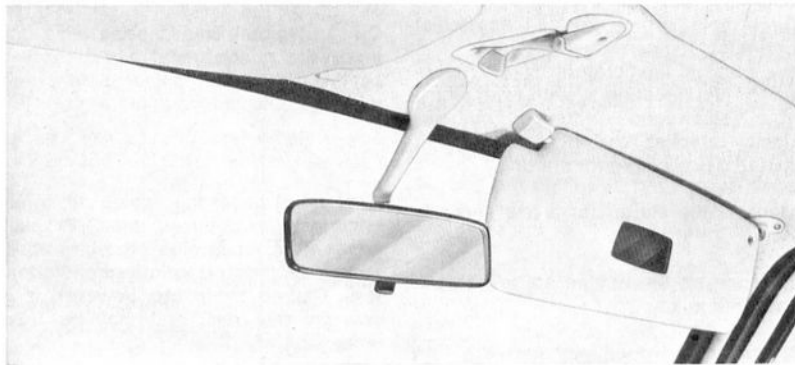

## Sliding roof

(optional equipment)

To open the sliding roof, pull the handle out and turn counterclockwise. To close the sliding roof, turn the handle clockwise. You can lock the sliding roof in any open position by folding the handle into its recess.

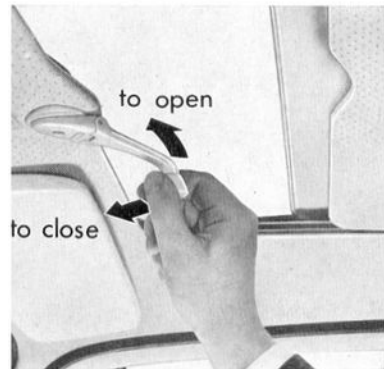

For safety reasons, make sure the handle is always recessed, as shown in the left illustration.



## Interior light (1)

The light has a built-in switch. You operate the switch by pressing on the sides of the lens. The three switch positions are:

Center position

- ON (with doors open)

Depressed on left

- OFF

Depressed on right

- ON (with doors closed)

## Assist straps and coat hooks (2)

There is one assist strap and one coat hook on each side on the door post. Hang clothes in such a way that they do not impair the driver's vision.

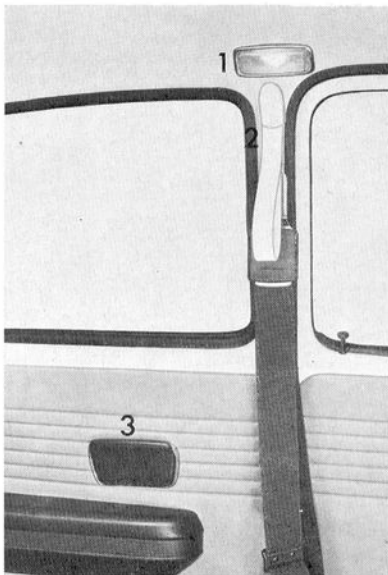

## Ashtrays

You will find an ashtray in the instrument panel and two in the rear passenger compartment.

### Front ashtray

Pull to open it. To remove the tray, depress the leaf spring which you see

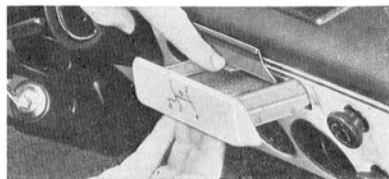

on the left just beneath the top cover. Now pull out the tray.

To put it back in, fold the top cover down, insert the tray in the guide rails and push in with the heel of your hand.

### Rear ashtray (3)

To remove the tray, depress the spring in the center of the tray to unhook it at the top. Now pull out. To reinstall the tray, hook the lower edge of the tray in its holder first, then depress the leaf spring and close the tray.

## Lockable glove compartment

To open

- Turn knob to left

To close

- Press door; lock engages

To lock or unlock

- Turn key to right or left.

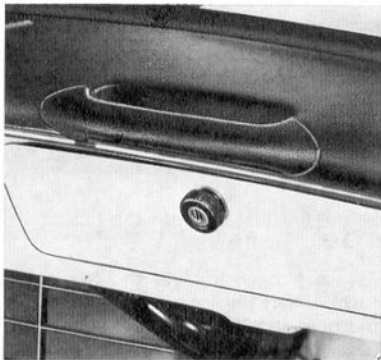

Inside the glove compartment is the **release lever for the front hood**. A locked glove compartment prevents access to the front luggage compartment and the spare wheel.

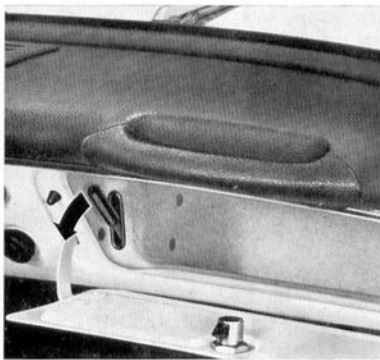

You will appreciate this feature when you carry personal items in your car and have to leave it open, for instance, at a garage or in a parking lot.

## Luggage compartments

**Your VW Type 3** has two luggage compartments, one under the front hood, and the other under the rear hood.

Since improper weight distribution can affect the car handling, take advantage of the two luggage compartments. Load the front luggage compartment first using the heaviest pieces of luggage if possible.

### Front luggage compartment

To **unlock** the front hood, pull the release lever inside the glove compartment. See previous page. The hood springs up slightly under spring pres-

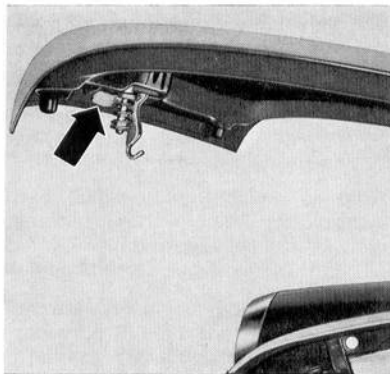

sure. To open it fully, pull the lever underneath the hood to disengage the hook.

To **lock** the front hood, lower the hood and press it down firmly. Always press down at the front near the lock. Make sure the hood is securely locked.

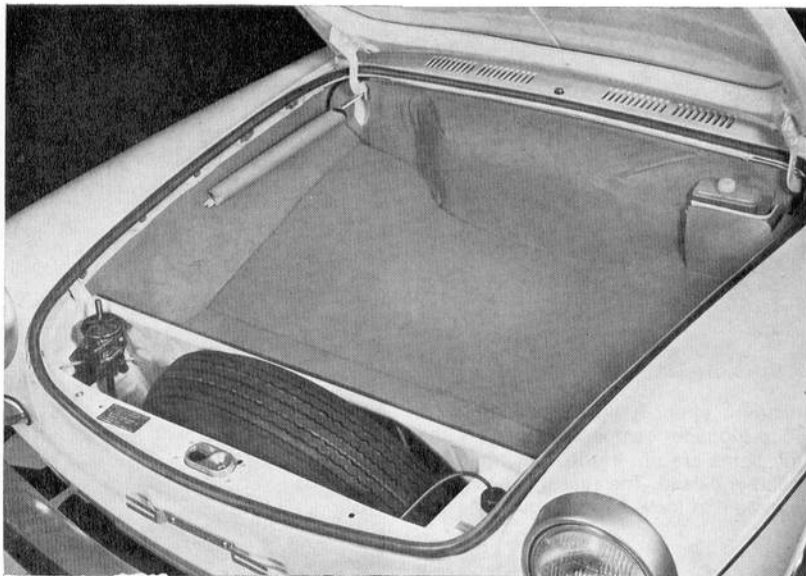

### Rear luggage compartment in the VW Type 3

Additional luggage can be stored in the luggage compartment under the rear hood. To **unlock** the rear hood, move the lever in the left door lock pillar outward (in direction of arrow). Lift

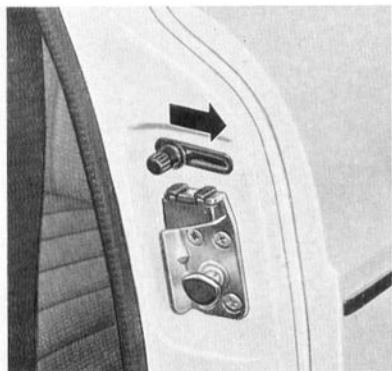

hood to open. A light illuminates the rear luggage compartment when the car lights are on. It goes out when the hood is closed. The rear luggage compartment is locked when you close the hood.

### Engine compartment in the VW Type 3

You have access to the engine through the rear luggage compartment. First fold or roll up the floor covering. Then turn the lid handle to the OPEN position and lift the lid. To hold the lid up, hook

the left handle onto a bracket on the upper edge of the body opening. Or you can also take out the lid. To close the engine compartment lid, do the opposite in reverse order.

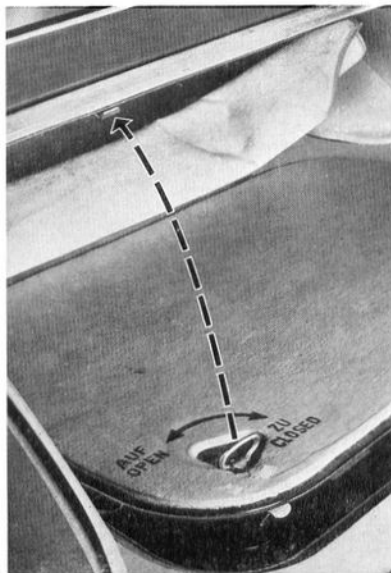

## VW Squareback Sedan

The **front luggage compartment** in the VW Squareback Sedan is the same as in the Type 3. For details see page 41.

The **rear luggage compartment** provides generous loading space.

For better car handling, distribute loads as far forward as possible. Make use of the two luggage compartments in your Squareback.

When transporting luggage or other cargo, secure it in place. This precaution will help prevent such articles from shifting during a sudden stop.

The rear luggage compartment is easily accessible through the lid at the rear of the car. You **lock** and **unlock** it with the ignition key.

**Do not drive with the rear luggage compartment lid open to preclude the possibility of exhaust fumes entering the car.**

**To open the lid**, depress the lock and raise the lid until it is held in the fully open position by the torsion springs. Do not let the lid fly open on its own.

**To close the lid**, swing it down firmly. Always make sure it is properly closed and locked.

**Do not allow children to kneel or sit on the rear load surface while the car is in motion.**

### **Increasing the load surface**

You can substantially increase the load surface by folding the rear seat to form a deck.

**When folding the rear seat, stand between the front and rear seats. Never do it from the rear luggage compartment. Always use the handle behind the top of the backrest when folding down or lifting the backrest. Keep hands away from hinges and folding edges.**

**To form a rear deck, proceed as follows:**

Lift the seat cushion, as shown in the illustration. Fold it toward you to an upright position. Tuck away the safety belts.



To release the backrest, lift the knob on the left, as seen in driving direction. Fold the backrest down by using the handle behind the top of the backrest.

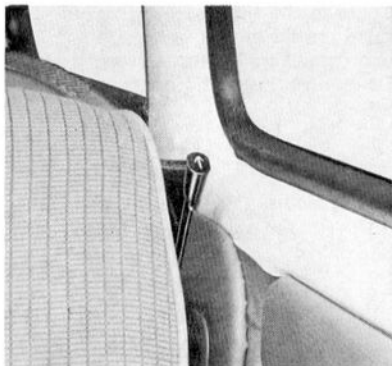

**To build the rear seat up again**

Grab the handle to lift the backrest. Reposition or hold up the safety belts to make sure they will be on top of the seat cushion when folding the seat cushion back.

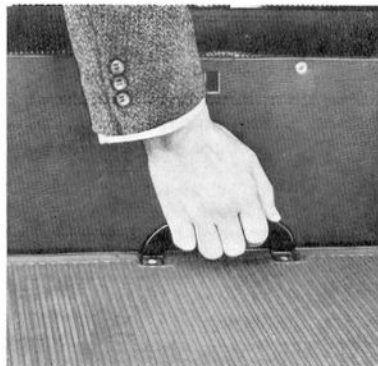

Backrest and seat cushion will lock in place automatically.

## **Engine compartment in the Squareback**

You have access to the engine from the rear. Roll the floor covering out of the way. Turn the lid handle to the OPEN position and lift the lid. To hold

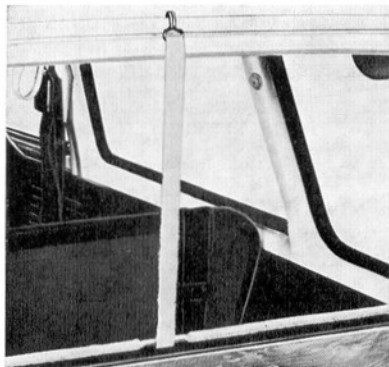

the lid up, hook the strap onto the rain gutter. Or you can also take out the lid. To close the engine compartment, reverse the procedure.

## Heater/Defroster

A fresh air heater/defroster is standard equipment on your Volkswagen. The control levers are located on the tunnel between the front seats.

### 1 a – Heater temperature lever

The lever toward the passenger's seat controls the temperature level.

Lever up – heat on fully

Lever down – heat off

By setting it at any intermediate position, you can select the degree of heat that is most comfortable for you. After a reasonable warm-up time, which also depends on the speed of your car, the warm air will enter the car through the three vents (1) at the lower edge of the windshield.

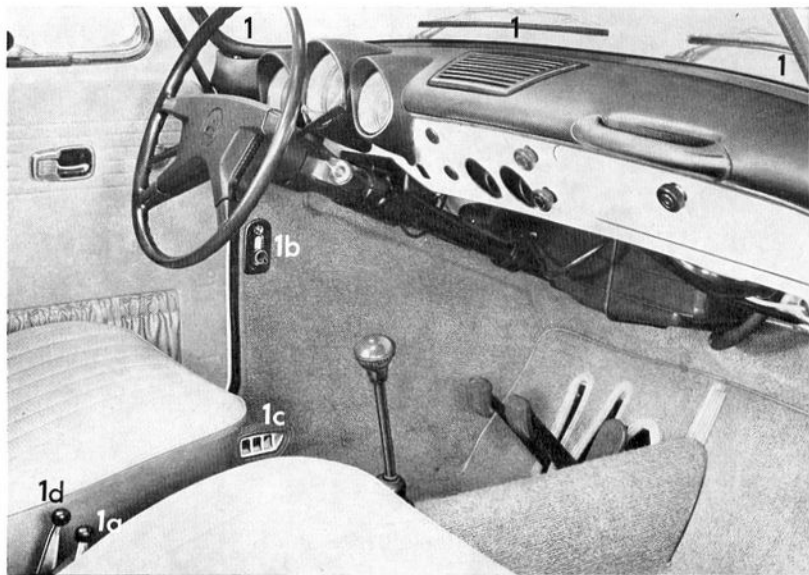



### **1 b and 1 c – Heat outlets and control knobs for front footwells**

For each side, there is a footwell heat outlet (1 c). It is located just beneath the door. You can control the flow of warm air from these outlets to the front footwells on each side with a knob (1 b).

- Knob up – open
- Knob down – closed

### **1 d – Heat control lever for rear footwells**

With the lever on the tunnel next to the driver's seat, you can control the heat in the rear footwells.

- Lever down
  - heat off in the rear
- Lever up
  - heat fully on in the rear

You can select any intermediate position to regulate the heat for the rear footwells.

### **Hints for defogging and defrosting**

Defogging and defrosting your windshield will be more effective if you direct the total air flow toward the windshield.

Here is what to do:

- Heater temperature lever (1 a)
  - all the way up – heat is on
- Heat outlet control knobs (1 b)
  - all the way down – no heat to the front footwells
- Heat control lever (1 d)
  - all the way down – not heat to the rear footwells

Now all air is directed toward the windshield.

## Ventilation

Flow-through ventilation provides a continuous draft-free exchange of air while driving. Air enters the car through the grille on the front hood and the inside vents below the windshield. A water separator prevents rain from entering.

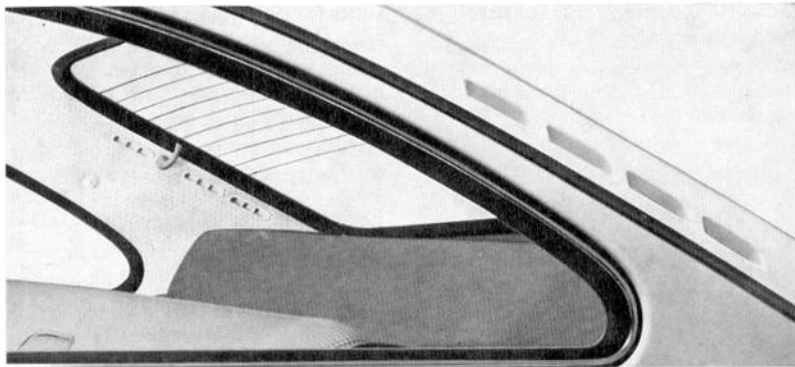

The air in the passenger compartment is drawn out through inside openings near the rear window and escapes to the outside through louvers.

A two-speed electric fan behind the instrument panel increases the flow of air when driving at low speeds and also supplies fresh air when the car is standing still (ignition on).

### 2 a and 2 b — Fresh air vents and outlets

Fresh air comes out through the vents below the windshield (2 a) and the outlets on the dashboard (2 b).

Volume and direction of the air coming from the outlets on the dashboard can be controlled separately by adjusting the flaps in the outlets (2 b). They can be opened or closed by pressing against one side of the flaps. When the flaps are closed, the entire volume of fresh air flows through the vents at the windshield (2 a).

### 18 — Fresh air control knobs

You can regulate the volume of fresh air for each side separately by turning the knobs.

Upper knob for right side

Lower knob for left side

Turn knobs to left

— air flow increases

Turn knobs to right

— air flow decreases

To stop the air flow completely, turn the knobs to the right beyond the pressure point.

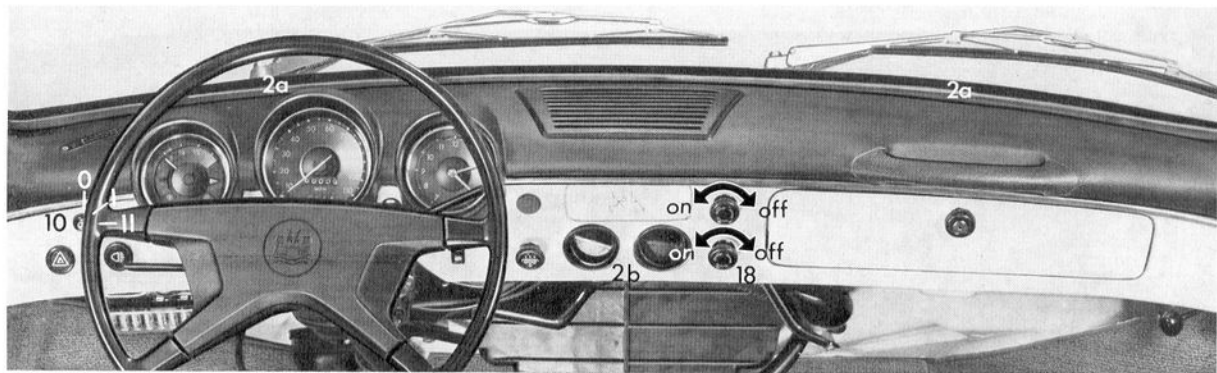

## 10 – Fresh air fan

You can increase the regular air flow by turning on the two-speed fan.

The switch positions of the fan knob are:

- 0 – OFF
- I – low speed
- II – high speed

The fan operation is most effective if you have turned the fresh air control knobs all the way to the left. To give you full battery power while starting the engine, operating fresh air fan will stop automatically at this moment.

## VW Air Conditioner (optional equipment)

### Operating controls

#### 1 – Air volume switch (“AIR”)

This switch serves two functions. It turns the air conditioning system on and off and controls the fan speed.

#### 2 – Air temperature switch (“COLDER”)

By progressively turning this switch to the right, the desired cooling range can be selected. It is in the coldest position when turned as far as possible to the right.

#### 3 – Air discharge louvers

These movable louvers can be adjusted by moving the center vane to direct the conditioned air flow upward, downward or sideways.

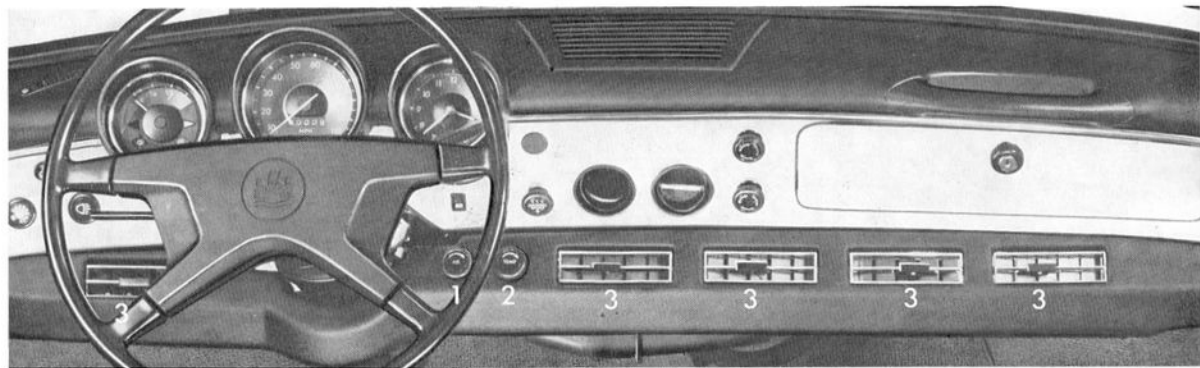

The fan positions are:

- 1st position – HIGH
- 2nd position – MEDIUM
- 3rd position – LOW

## Starting the Air Conditioner

With the engine running, windows and fresh air regulator closed, turn the air temperature switch to the desired position and select the air volume speed desired. On extremely hot days turn the air volume to full capacity and open a window. Within a few minutes, the hot air will be forced out of the car and the window can be rolled up as cooling starts.

Adjust the air discharge louvers to the desired position.

## Stopping the Air Conditioner

Turning the air volume switch to the "OFF" position stops the entire air conditioning system.

When shutting off the engine, the air conditioner should also be turned off and not turned on again until the engine is running. This is to reduce the load on the electrical system and conserve the battery.

## Operational hints

If the volume of cold air suddenly decreases it is likely that the evaporator coil is "icing up". To remedy this, turn the air temperature switch to the left and leave in this position until the air volume is back to its original rate.

If the car interior becomes too cold after adjusting the air volume, turn the air temperature switch to the left until the desired comfort level is reached.

If the windows fog over on the **exterior** on warm, humid days, turn the air temperature switch to the left until the windows clear up, or turn the windshield wipers on.

If the windows fog over on the **interior**, they can be quickly cleared by turning on the air conditioner.

During highway driving, set the air temperature switch in approximately the middle position.

## Maintenance hints

During the winter season, it is advisable to operate your Air Conditioner for a brief moment every week. This will help to keep the seals and fittings properly lubricated.

After the winter months and before extended summer usage, the air conditioner should be checked and, if necessary, serviced by an Authorized VW Dealer.

The condenser located behind spare wheel well should be checked periodically for cleanliness. If clogging in any area exists, wash condenser with water. If the condenser fins are bent, the car should be taken to an Authorized VW Dealer for straightening of the condenser fins.

## Circuit breaker

An automatic resetting circuit breaker for the current supply of the air conditioning system is located under the rear seat. It is connected directly to the battery.

## VW Auxiliary Heater (optional equipment)

Do not start or let the engine or heater run in an enclosed, unventilated area to warm up the car. Exhaust fumes from the engine or gasoline heater contain carbon monoxide, which is colorless and odorless. Carbon monoxide, however, is a very harmful gas, and may be fatal when inhaled.

To switch the heater on, pull the knob (arrow) out. This lights up a green warning lamp in the knob.

To avoid an unnecessary drain on the battery switch the heater off after about 25–30 minutes if the engine has not been started in the meantime.

To switch the heater off, push the knob in. The warning lamp then goes out but the blower motor continues to run until the heater has cooled down.

**The heater must be switched off when filling the tank.**

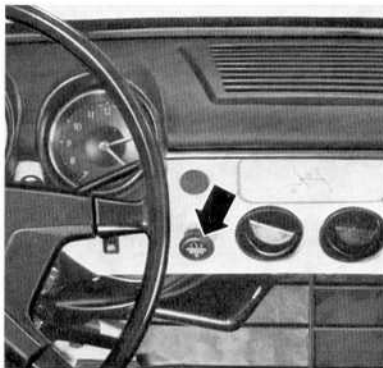

When it is very cold, the full battery capacity is required to start the engine. To avoid starting difficulties, it is advisable, not to preheat the vehicle interior under these conditions, that is to say, do not switch the heater on until the engine is running.

The heater normally requires no special maintenance. It is advisable, however, to have the heater plug checked once a year before the cold weather sets in and a new plug installed if necessary. The fuel system should also be checked for cleanliness and the electrical connections for tightness.

During the winter and when driving over very poor roads, mud or snow may tend to accumulate in the exhaust and combustion air intake pipes. Have these pipes checked for blockage from time to time so that the heater continues to work properly.

When the heater is not used for long periods, for instance during the summer, gum-like deposits from the fuel can settle in the fuel lines. To avoid trouble due to these deposits, it is advisable to operate the heater briefly about once a month when it is not in regular use.

Heat output . . . . .	8 000 BTU/h
Fuel . . . . .	Gasoline from fuel tank
Fuel consumption	approx. 0.7 US pint/h (0.6 Imp. pt/h)
Current consumption . . . . .	40 Watts

## Trailer hauling

It is possible to tow a trailer with your Volkswagen. When towing a trailer, start out in a lower driving range (Automatic Transmission) with this extra load. Also, shift to a lower gear or range when driving up or down steep hills.

The total weight of a trailer (without brakes) should not exceed 1025 lbs. on the Type 3 and 1080 lbs. on the Squareback Sedan.

The trailer tongue load should be 55 to 90 lbs. Distribute load in the trailer evenly.

And remember: the additional trailer weight affects the braking of your car so that a longer distance is needed to bring the car and trailer to a stop. Test the brakes before starting out on a trip with a trailer.

# Towing

**Always observe state laws and municipal ordinances governing towing.**

## Manual Transmission

When towing your Volkswagen with Manual Transmission, place the gearshift lever in Neutral. Turn the ignition on to be able to operate headlights, turn signals and stop lights. Be sure to release the parking brake.

## Automatic Transmission

When towing your Volkswagen with Automatic Transmission, please also observe the following in addition to the items listed under Manual Transmission:

The towing speed should not exceed 30 mph, and the towing distance should not be longer than 30 miles. This is very important because the transmission will not be adequately lubricated due to the lack of oil pressure normally provided when the engine is running. These limitations do not apply if the car is lifted at the rear or if the drive shafts are disconnected.

Your Volkswagen is equipped with two towing eyes: one at the front on the right lower section of the axle beam

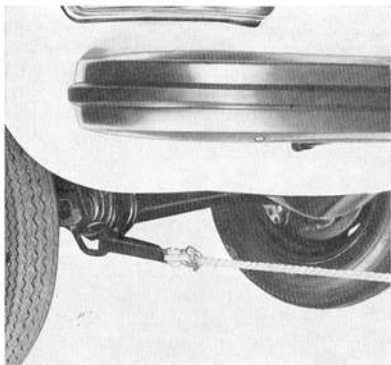

and the other underneath the right rear bumper bracket. They are for emergency towing and short distances only.

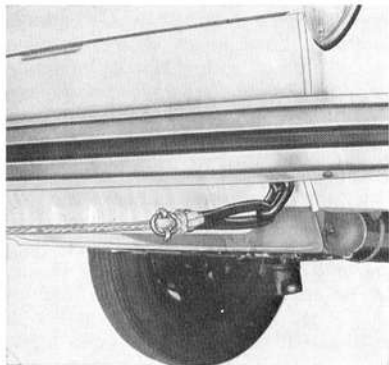

### **Please keep in mind . . .**

The towing eyes on your Volkswagen are not designed for towing by commercial tow trucks. Also, never have your VW towed by the bumper.

The driver of the towing car must be very careful when driving off and shifting to avoid sudden and abrupt pulls.

The driver of the towed car must always keep the tow rope taut.



## Winter operation

Your Volkswagen has an air-cooled engine. Do not, under any circumstances, try to influence the heating of the vehicle by covering up the louvers in the rear fenders. These louvers must always be clear so that air can flow into the fuel injection system and to the engine cooling fan.

### Battery

During the winter months, the battery is subjected to greater use than in the summer months. More current is consumed when starting at very low temperatures. Lights and the rear window defogger are more often used. Besides, the battery tends to decrease in capacity as the temperature drops.

Therefore, it is very important to keep your battery in best possible condition. See also "Battery" on page 72.

**Do not expose battery to open flame or electric spark as hydrogen gas generated by the battery is explosive. Do not let battery acid come in contact with skin, eyes, fabric or painted surfaces.**

A really cold battery may not be fully charged, and therefore does not have the same capacity as a battery at normal temperature. If you mainly drive short distances or in city traffic, have the battery checked and, if necessary, charged between regular inspections.

### Door locks

can freeze in the winter if water gets into them. When washing your car in the winter, do not aim the water jet directly at the locks. It is a good idea to put tape over the keyholds to prevent the water from seeping in. Water in the locks must be removed with compressed air afterwards. Squirt lock de-icer, anti-freeze, or glycerine into the lock cylinders to prevent the locks from freezing.

To open a frozen lock, warm up the key before inserting it. It might also help to warm the lock. Do not use hot water as it will later freeze in the lock.

### Emergency equipment

It is good planning to carry emergency equipment in your car. Some of the things you should have are:

window scraper, snow brush, container or bag of sand or salt, flares, small shovel, first-aid kit, etc.

### **Engine oil**

To make starting easier during the cold winter months, we suggest you choose a thinner grade motor oil. Turn to page 93 for the recommended oil grades.

If you drive mostly short distances and in city traffic, we recommend you have your engine oil changed at 1500-miles intervals in the winter.

### **Transmission oil**

SAE 90 grade transmission oil can generally be used all year round. Only in areas with a cold climate is it necessary to use the thinner SAE 80 transmission oil during the winter months.

In arctic climate and areas with temperatures consistently below  $-13^{\circ}\text{F}$ , use Automatic Transmission Fluid (ATF) for the manual transmission and final drive. This does not apply to the final drive of the Automatic Transmission. When the temperature rises, replace the ATF with SAE 80 or SAE 90 grade transmission oil. See also page 94.

### **Windshield washer**

Add anti-freeze to the washer fluid, such as Volkswagen's Windshield Washer Anti-freeze & Solvent, to prevent it from freezing. Follow the instructions on the can for the right amount to be used.

### **Spark plugs**

Make sure the spark plugs are not worn or have a gap larger than 0.028 inch.

For further details on spark plugs see page 82.

## Tires



Your Volkswagen is equipped with tubeless bias ply tires. Size 6.00 – 15. Volkswagen tires comply with all applicable U. S. Federal Motor Vehicle Safety Standards.

For maximum safety, always buy replacement tires that show the same specifications with regard to tire size, load carrying capacity, tread pattern, etc. This also applies to VW-recommended alternate replacement tires.

## Tire pressures

For good car handling and long tire service life, it is important to maintain recommended tire pressures. Tires which are inflated above or below specifications can cause increased tire wear, increased gas consumption and affect the road holding of the car.

VW-recommended **cold tire inflation pressures** are listed on a sticker on the inside of the glove compartment door. See also page 98. They are:

Type 3	front	rear
With 1–2 occupants	17 psi 1.2 kg/cm <sup>2</sup>	26 psi 1.8 kg/cm <sup>2</sup>
Fully loaded	18 psi 1.3 kg/cm <sup>2</sup>	29 psi 2.0 kg/cm <sup>2</sup>

For long, high-speed driving the tire pressure should be increased by 3 psi (0.2 kg/cm<sup>2</sup>) at front and rear.

### Squareback Sedan

With half payload	17 psi 1.2 kg/cm <sup>2</sup>	26 psi 1.8 kg/cm <sup>2</sup>
With full payload	18 psi 1.3 kg/cm <sup>2</sup>	36 psi 2.5 kg/cm <sup>2</sup>

## Do not exceed the maximum tire inflation pressure listed on the tire label.

In the interest of safety, check the tire pressure of all tires, including the spare tire, at least once a week, and always before going to a long trip.

## Spare tire pressure

Since the spare tire supplies the pressure to operate the windshield washer, the pressure of the spare tire should be between 29–42 psi (2.0–3.0 kg/cm<sup>2</sup>). For the Squareback Sedan, it should be up to a maximum of 56 psi (4.0 kg/cm<sup>2</sup>).

This pressure level is only to be maintained for the operation of the windshield washer system. For road use, the pressure in the spare tire should be adjusted as specified on the left side of this page. See also page 98.

## Tire rotation

If uneven tire wear should occur, we recommend that the tires be rotated, as shown in the sketch below. Afterwards, the tire pressures must be corrected, and the wheel bolts torqued diagonally to 110 ft.lbs.

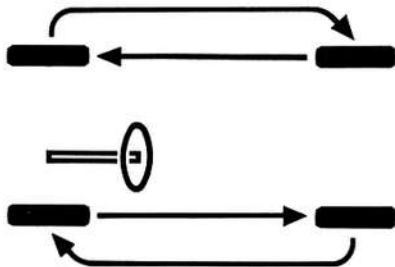

## Wheel balancing

A wheel should always be balanced after a tire repair. Also, since regular use can cause tire imbalance, the wheels should be balanced from time to time. Unbalanced wheels may affect car handling and tire life.

## Tire wear

The original equipment tires on your VW have built-in tread wear indicators. They are molded into the bottom of the tread grooves and will appear as approximately  $\frac{1}{2}$  inch bands when the tire tread depth becomes  $\frac{1}{16}$  of an

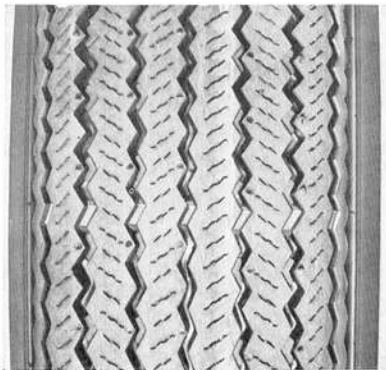

Tire in good condition

inch. When the indicators appear in two or more adjacent grooves, it is time to replace the tires. We recommend, however, that you do not let the tires wear down to this extent. Worn tires cannot grip the road surface pro-

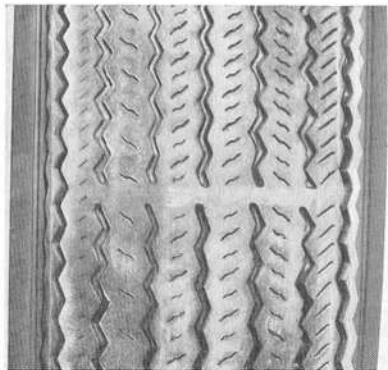

Indicator visible – tread worn

**Do not drive with worn tires or tires showing cuts or bruises as they may lead to sudden deflation.**

perly, and are even less effective on wet roads.

If you notice that tires are wearing unevenly, consult your Authorized VW Dealer. Uneven wear may not always be due to improper wheel alignment. It can be the result of individual driving habits such as cornering at high speeds. If the tire pressure is not checked and adjusted regularly, abnormal tire wear can also occur.

## Tire replacement

To achieve best all-around car handling, replace all 4 tires at the same time. If this is not possible, replace tires in pairs, either front or rear.

Do not combine tires of different designs, size or tread pattern.

New tires do not possess maximum traction. They tend to be slippery. Break new tires in by driving at moderate speed for the first 60–100 miles.

### Winter tires

Winter tires give good traction in snow or slush.

For a better grip on hard snow or ice, you can use snow tires with studs, but **check with your State Motor Vehicle Bureau** for possible restrictions. Winter tires with studs should be run at moderate speed when new to give the studs time to settle.

Winter tires should preferably be mounted on all four wheels. They should also conform to the same load requirements as original equipment tires. For winter driving, the tire inflation pressure on the Volkswagen Type 3 can be increased by 3 psi (0.2 kg/cm<sup>2</sup>) above the normal operating pressures, as is also recommended for fast highway driving, **but do not exceed the maximum tire inflation pressure listed on the tire label.**

When winter tires are fitted, it may be necessary to fit clips on the lower torsion arms of the front axle to prevent the tires from rubbing in the wheel housing on full lock.

Snow tires do not fulfill their purpose if the tread depth is less than  $\frac{5}{32}$  in. For safety reasons, it is not advisable to drive with snow tires at top speeds. Snow tires do not have the same degree of traction on dry, wet or snow-free roads as regular tires.

### Tire care

- 1 – Frequently check tires for damage. Remove imbedded material.
- 2 – Keep oil and gasoline away from tires.
- 3 – Replace worn tires or studs in time.
- 4 – Replace missing valve dust caps as soon as possible.

## Spare wheel

The spare wheel is stored in an upright position in the spare tire well under the front hood.

To **unlock the hood**, pull the lever inside the glove compartment. See also page 40.

The spare wheel is connected to the windshield washer container and supplies the pressure to operate the washer. The air supply to the windshield washer will be interrupted automatically by a cut-off valve if the tire pressure drops to 29 psi (2.0 kg/cm<sup>2</sup>); in the Squareback Sedan 36 psi (2.5 kg/cm<sup>2</sup>). This prevents the spare tire from being deflated below the required pressure.

Check the spare tire pressure from time to time and maintain it up to a maximum of 42 psi (3.0 kg/cm<sup>2</sup>); in the Squareback Sedan up to 56 psi (4.0 kg/cm<sup>2</sup>).

This pressure level is only required for the operation of the windshield washer system. For road use, adjust the spare tire pressure as specified on page 58.



To check or correct the pressure, first unscrew the windshield washer hose from the valve of the spare tire (arrow). Reconnect the hose firmly after checking or inflating the spare tire.

## Jack

The jack is only used for changing a wheel. Do not use it as a support to work underneath the car.

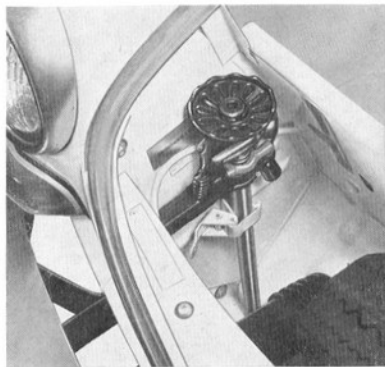

The jack is located next to the spare wheel under the front hood. See also previous page. It is held in stowage position by a clamp. To take out the jack, open the clamp first. After use, place the jack back in its stowage position and close the clamp.

### Note

There are two types of jacks, as shown below. Your Volkswagen is equipped with either one of these types.

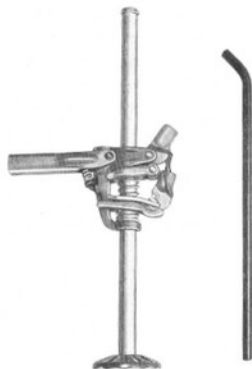

### Jack with lever

(The long breaker bar serves as the lever; it is in the tool kit).

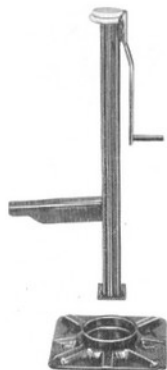

### Jack with crank

(The base plate comes with the tool kit)



## Changing a wheel

If you have a flat tire, **move off the roadway. Turn on the emergency flasher. In addition, mark the position of your car with flares or other warning devices to alert other motorists.**

Before you change a wheel, be sure, **the ground is level and firm, especially near the rear wheels where the jack ports are.**

**Set the parking brake and block the wheels opposite the defective wheel on the other side of the car.**

For a more efficient and safe changing of a flat tire, observe the following 10 steps.

**Further down, we expand on these steps in greater detail.**

Step 1 – Take out tools, jack and spare wheel.

Step 2 – Remove hub cap.

Step 3 – Loosen wheel bolts.  
**Do not take them out.**

Step 4 – Securely insert the jack in jack port. There is **one** for each side. It is under the body toward the rear, and is used for front or rear wheel changing.

**Never jack the car up the bumper or the body.**

Step 5 – Jack up car.

Step 6 – Change wheel and hand-tighten wheel bolts.

Step 7 – Lower car.

Step 8 – Further tighten the wheel bolts.

Step 9 – Replace hub cap.

Step 10 – **Important**  
Torque adjustment.

**Step 1 –**

Take out your tool kit.

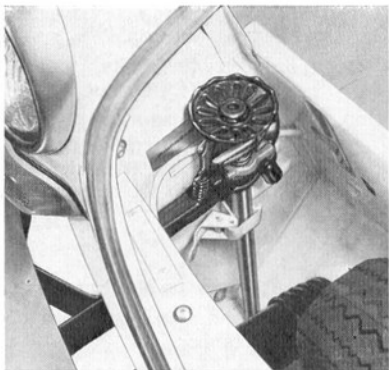

Take out the jack from under the front hood next to the spare wheel. To unlock the hood, pull the lever inside the glove compartment. Open the clamp that holds the jack in stowage position.

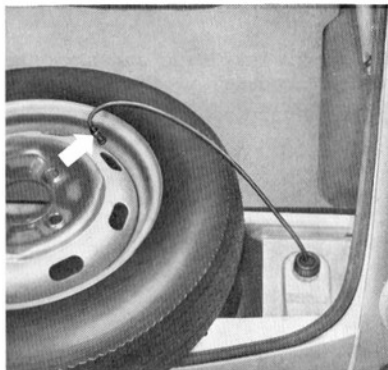

Before you take out the spare wheel disconnect the hose (arrow) leading to the windshield washer container. To have better access to the valve of the spare tire, lift the spare wheel out of its well and place it on the edge of the car frame.

### Step 2 —

With the wheels still firmly resting on the ground, remove the hub cap of the defective wheel.

#### Tools with special hub cap puller:

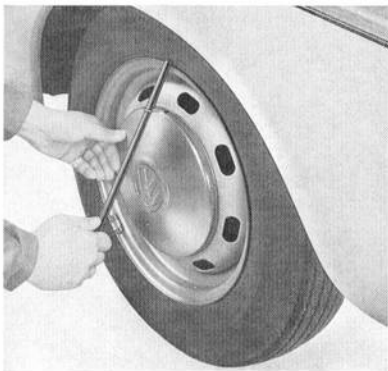

Insert the puller in the holes at the rim of the hub cap. Put the breaker bar through the puller, brace one end of the bar on the wheel rim and tug lightly on the other end.

**Note:** There are two types of tool kits. Your Volkswagen is equipped with either one of these kits.

#### Tools with breaker bar acting as hub cap remover:



Insert the flat end of the breaker bar between hub cap and rim and pry off. When you place the hub cap inside out you can use it as a tray for your wheel bolts.

### Step 3 —

Loosen all wheel bolts counterclockwise about one turn with the socket wrench. Insert the breaker bar to make full use of its leverage. **Do not yet remove the bolts.**



#### Step 4 –

Securely insert the jack into the jack port. There is one on each side under the body toward the rear and is used for front and rear wheel changing.

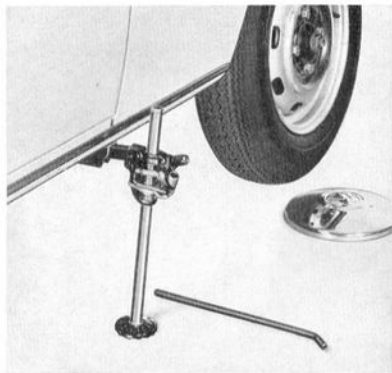

Provide for a **firm base for the jack on the ground**. If necessary, use a brick, a board, a flat rock, etc. Use the **base plate** that comes with the **jack with crank**. It is provided for this purpose.

Passengers should not remain in the car when the car is jacked up.

**Never jack the car up by the bumper or body.**

#### Step 5 –

##### **When using jack with lever**

To raise the car, insert the breaker bar in the upper slot – a – and pump the bar.

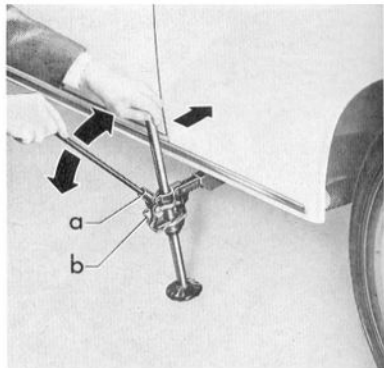

To get the jack as vertical as possible, push the upper part of the jack toward the body while you are jacking up the car.

**When using jack with crank**

To raise the car, turn the handle clockwise.

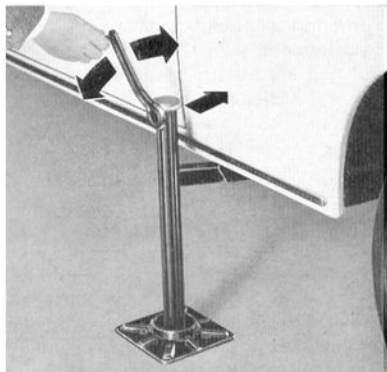

Only raise the car as much as is needed to change a wheel.

**Do not raise the car until you are sure the jack is securely engaged.**

**Step 6 –**

Fully unscrew the wheel bolts and place them into the hub cap. Take the bolt at the top off last. Place the spare wheel against the wheel hub and slightly rotate the wheel until a bolt hole in the wheel is in line with a threaded hole in the wheel hub. Insert the wheel bolts and handtighten them crosswise before jacking the car down.

**Step 7 –****When using jack with lever**

To lower the car, insert the breaker bar in the lower slot – b – and pump the bar.

**When using jack with crank**

To lower the car, turn the handle counterclockwise.

**Step 8 –**

Then go crosswise from one bolt to another tightening them firmly with the socket wrench and breaker bar.

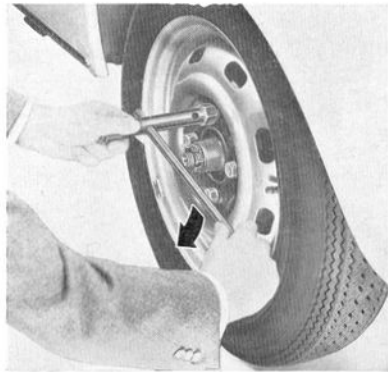

**Step 9 –**

To install the hub cap, place it around the lower part of the wheel center, and with a firm push on the upper part, the hub cap will snap into place. Make sure it is properly seated.



**Step 10 –**

**Correct tightness of the wheel bolts is important.**

Tighten bolts diagonally to 110 ft. lbs. Have the bolts checked by your dealer or a service station with a torque wrench.

Also correct the pressure of the tire you have just put on.

## Container for windshield washer fluid (1)

The windshield washer container has a capacity of 3.5 US pints (3.0 Imp. pt). To add washer fluid, just unscrew the filler cap. The container can be filled to the top.

As clear water is usually not adequate for cleaning the windshield, add a cleaning solution to the water such as Volkswagen's Windshield Washer Anti-Freeze & Solvent. It is a concentrate, so follow the directions on the can for the correct amount to be used.

You can use Volkswagen's Windshield Washer Anti-Freeze & Solvent all year round. It helps to keep your windshield clean, and prevents freezing of the washer fluid in the winter.

Since the spare tire supplies the pressure to operate the washer, it should always be kept up to a pressure of 42 psi (3.0 kg/cm<sup>2</sup>). In the Square-back Sedan, the spare tire pressure should be kept up to 56 psi (4.0 kg/cm<sup>2</sup>).

How to pressurize the spare wheel, see page 61.

## Brake fluid reservoir (2)

The brake fluid should always be above the seam edge near the top of the reservoir. If it drops below this point, the cause should be corrected by your Authorized Volkswagen Dealer.

**Every 2 years, the brake fluid has to be replaced.**

See "Additional Services Record" on page 117 and "Scheduled Maintenance" on page 121.

Only **new, unused** brake fluid that meets the SAE recommendation J 1703 must be used.

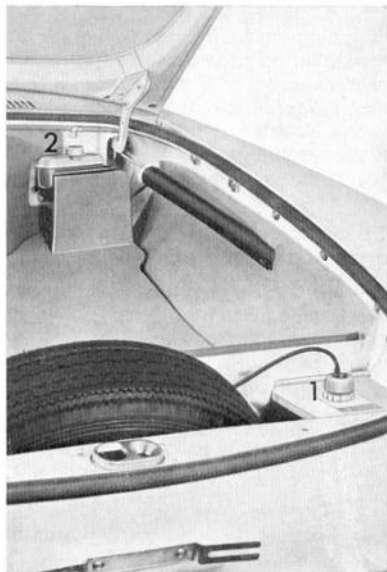

## Fuses

The 12-point fuse box with plug-in arrangement for relays is located under the instrument panel on the left of the steering column.

The embossed symbols on the transparent cover identify the main fuses.

When a fuse is blown, it is not sufficient to merely replace it. The cause of the short circuit or overload must be found. On no account should fuses be patched up with tin foil or wire as this may cause serious damage elsewhere in the electrical circuit. It is advisable to always carry a few spare 8 amp and 16 amp fuses in your car.

To replace a fuse, simply depress a contact on either side of the fuse.

There are ten 8 amp fuses (white) and two 16 amp fuses (red). Nr. 9 and Nr. 10 are the two 16 amp fuses.

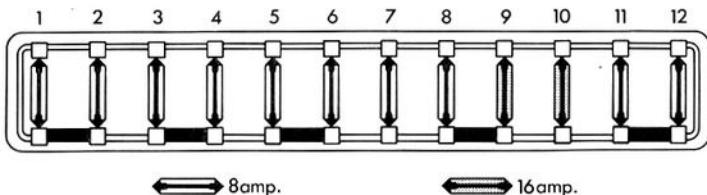

- 1 – Tail light, right;  
License plate light;  
Parking and side marker lights;  
Luggage compartment light  
(Type 3 only)
- 2 – Tail light, left
- 3 – Low beam, left
- 4 – Low beam, right
- 5 – High beam, left;  
High beam indicator light
- 6 – High beam, right
- 7 – Electric fuel pump for fuel injection

**DO NOT attach any other equipment here!**

- 8 – Emergency flasher;  
Interior light
- 9 – Buzzer
- 10 – Windshield wipers;  
Fresh air fan;  
Rear window defogger (switch current)
- 11 – Stop lights;  
Turn signals;  
Horn;  
Brake warning light
- 12 – Accessories



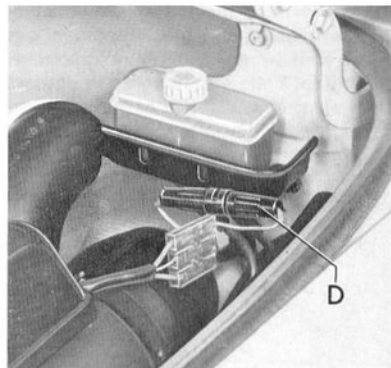
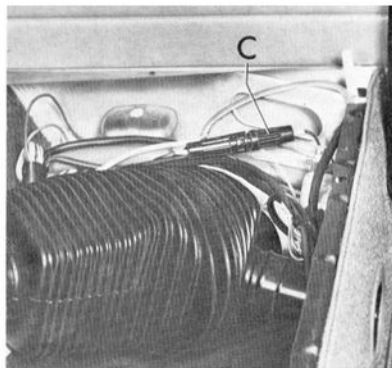
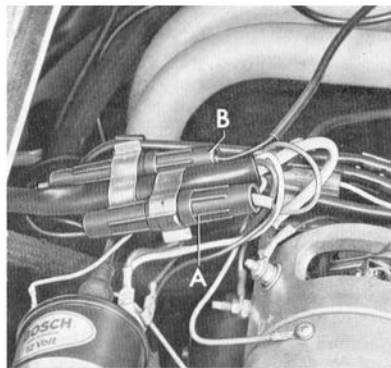

### Additional fuses

### Electrical equipment

### Fuse

### Location of fuse holder

Back-up lights

8 amp.

in the engine compartment near the ignition coil (A)

Kickdown  
(Automatic Transmission only)

8 amp.

in the engine compartment near the ignition coil (B)

Rear window defogger  
(main current)

8 amp.

underneath the rear seat on the left (C)

Auxiliary Heater  
(optional equipment)

16 amp.

in the front luggage compartment near the heater (D)

## Battery

**Do not expose the battery to an open flame or electric spark. Hydrogen gas generated by the battery is explosive. Do not let battery acid come in contact with skin, eyes, fabric, or painted surfaces. Keep the battery out of reach of children.**



The battery is under the rear seat on the right, as seen in driving direction. Just tilt the rear seat out of the way.

The electrical system depends mainly on the battery. Therefore, the battery should be checked regularly and kept in a good working condition.

**Never drive the car with a disconnected battery as this may damage the electrical system.**

Each filler plug has to be unscrewed to check the fluid level in each cell. If it is **below** the indicator, top it up with distilled water. **Only fill up to indicator.**

How often the battery has to be topped up depends mainly on operating conditions and on the time of year. As a general rule, the battery electrolyte level must be checked more often in the summer than in the winter, and more often when driving long distances.

The terminals and connections should be kept clean and greased with silicon spray or petroleum jelly. Make sure the ground connection to the body is free of corrosion and tight.

**When working on the battery, be sure not to short circuit the terminals. This would cause the battery to heat up very quickly, which could lead to damage.**

Before having a quick-charge performed on a battery installed in a car, **disconnect both terminals to avoid serious damage to the electronic components of the electrical equipment.**

If you have not used your car for an extended period of time, have the battery recharged.

## Fuel supply

Never start or let the engine run in an enclosed unventilated area. Exhaust fumes from the engine contain carbon monoxide which is colorless and odorless. Carbon monoxide, however, is a very harmful gas, and can be fatal when inhaled.

The engine requires "Regular" gasoline with a minimum octane rating of 91 (RON). In the interest of cleaner air, the VW engine is designed to run also on low-lead or lead-free gasoline. If regular fuels with adequate anti-knock qualities are not available, premium fuels should be used or mixed with the regular fuel.

When travelling outside the United States or Canada, regular gasolines may have a considerably lower octane rating. Therefore, make sure the gasoline that you are using does not have an octane rating lower than 91.

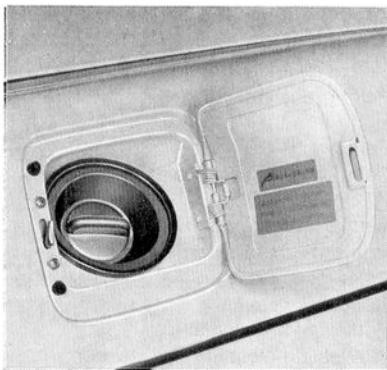

The filler neck to the fuel tank is in the right front fender. The flap opens when you pull the release strap on the right underneath the instrument panel.

The fuel tank has a capacity of 10.6 U. S. gallons (40 liters or 8.8 Imp. gal.). When putting the cap back on, twist it to its stop.

**The Auxiliary Heater (optional equipment) must be turned off when filling the tank.**

## Cleaning your VW

The paint on your VW is very durable, and so is the upholstery. But a car can get a lot of abuse from industrial fumes and corrosive road salt to half-eaten lollipops and muddy dog feet.

A well-cared-for VW can look like new 10 years later. It all depends on the owner and the amount of care he is willing to give to his car.

Here are a few hints on how to keep your VW looking young and beautiful.

We have also compiled a list of cleaning products. They are available at any VW dealer.

Whenever using VW-recommended products or other cleaning agents, **follow the directions on the containers. Be aware of warning or caution labels.**

Application	Volkswagen Product
Car wash and liquid wax	Car Wash and Wax – ZVW 243 201
Paint preservative	Paint Preservative and Wax – 000 096 011
Paint waxing	Classic Car Wax – ZVW 246 101
Paint polishing and paint waxing	Combination Car Cleaner and Wax – ZVW 241 109
Paint polishing, remove paint oxidation	Paint Polish – 000 096 001
Preservation of chrome parts	Chrome Preservative – 000 096 067
Paint touch-up	Touch-Up Paint (all colors)
Upholstery cleaning, Whitewall tire cleaning	All Purpose Cleaner – ZVW 243 101
Windshield cleaning and washer anti-freeze	Windshield Washer Anti-Freeze & Solvent – ZVW 241 101

**When cleaning upholstery and carpet, never use gasoline, kerosine, naphta, nail polish remover or any other volatile solvents. They may be toxic or flammable and therefore hazardous. Keep all cleaning agents out of reach of children.**

### **Washing your VW**

The longer the dirt is left on the paint, the greater the risk of damaging the glossy finish, either by scratching if the dirt is rubbed into the paint, or simply by the chemical effect dirt particles have on the paint surface.

Therefore dirt should be washed off as soon as possible.

### **NEVER WASH IN DIRECT SUNLIGHT.**

Use plenty of water, a car-wash soap, such as VW's Car Wash and Wax, and a soft sponge or hose brush. Begin with spraying water over the dry car to remove all loose dirt before applying the lukewarm soap/water solution. Use plenty of water to rinse the car off well. Wipe the car dry with a chamois to avoid water spots.

### **Waxing**

Waxing is not really needed when you have washed your car with VW's Car Wash and Wax. If you do not use a car wash liquid with wax, apply Paint Preservative and Wax to preserve the natural shine of the car.

To obtain a long lasting wax finish apply hard wax, such as VW's Classic Car Wax, after eight to ten weeks after buying the car. Wax again when water remains on the surface in large patches instead of forming beads and rolling off.

### **Polishing**

Use a polish such as VW's Paint Polish later in the car's life when the paint appears dull and loses its shine. **Do not polish the new car.** Always apply wax after polishing.

### **Cleaning windows**

Clean windows with a sponge and warm water. Dry with a chamois.

### **Weatherstrips**

To seal properly, weatherstrips around windows and doors must be pliable. To retain flexibility of the rubber, spray with silicone, available from your VW dealer, or coat with talcum powder.

### **Windshield wiper blades**

Remove the wiper blades periodically and scrub with a hard brush and alcohol or a strong detergent solution.

### **Chrome care**

To protect the car's chrome, apply VW's Chrome Preservative.

### **Touch-up paint**

Your dealer has touch-up paint for minor scratches and stone chips. Scratches should be touched up soon after they occur.

### **Care of chassis**

The underside of the car picks up dirt and salt and should be sprayed with a powerful jet of water. This is easier to do after the car has been driven in rain.

**Do not use gasoline, kerosine, naphta, nail polish remover or other volatile cleaning fluids. They may be toxic or flammable or hazardous in other ways. Only use spot removing fluids in well ventilated areas. Keep them out of reach of children.**

### **Removing spots**

#### **Tar**

Do not permit tar to settle on the paint finish. Remove it early with a cloth soaked with a special paint cleaner, such as Paint Preservative and Wax. If you do not have a spot remover, you may substitute with turpentine. After applying a cleaning fluid, always wash with a lukewarm soap/water solution and apply a new wax coat.

#### **Insects**

Remove early with a lukewarm soap/water solution or apply insect remover.

#### **Tree sap**

Remove with a lukewarm soap/water solution. Do not permit tree sap to harden on the paint surface.

### **Cloth upholstery and carpet**

Clean with a vacuum cleaner or a hard brush. Dirt spots can usually be removed with a lukewarm soap/water solution.

Use spot remover for grease and oil spots. Do not pour the liquid on the cloth material. Dampen a clean cloth and rub carefully, starting at the edge and working inwards.

### **Leatherette and interior trim**

Use VW's All Purpose Cleaner or a dry foam cleaner.

Grease or paint spots can be removed by wiping with a cloth soaked with VW's All Purpose Cleaner. Leatherette parts of the headliner and side trim panels can be cleaned with a soft cloth or brush and All Purpose Cleaner.

## Removing and installing seats

### Removing front seats

Roll the carpet out of the way. To protect the floor covering, put paper in the front footwell.

With the adjusting lever raised (1), slide the seat all the way forward until the runner touches the leaf spring stop (2).

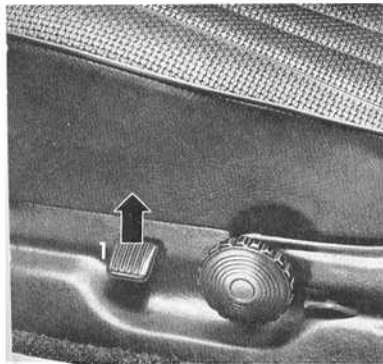

Depress the leaf spring stop on the inboard side of the seat with a screwdriver, as you slide the seat approximately 1 1/2 inches forward.

Stand outside the car, slide the seat fully off the tracks and lift it out.

### Reinstalling front seats

Stand outside the car and position the seat in front of the tracks. Hook the inboard seat runner on its track first. Then insert the outer runner by pulling the seat slightly toward you. Push the seat back to the leaf spring stop.



With the adjusting lever raised, slide the seat further back to the desired position.

### Removing and installing rear seat

To remove the seat, lift it at the front edge and pull it slightly toward you. Tilt it on one side for easier removal.

To put the seat back in again, lift it into the car holding it diagonally.

Place it on the front edge of the seat

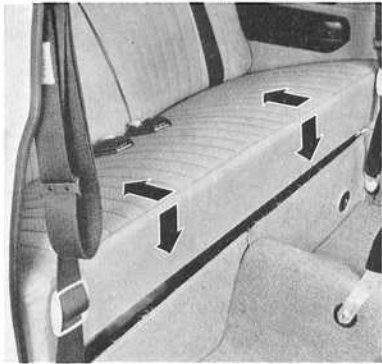

frame, and, with the front end tilted up, slide the seat fully back under the backrest. Position the safety belts, on top of the seat cushion. Press down the front end of the seat to firmly position it on the pegs that hold the seat cushion in place.

## Bulb chart

Bulb for	US Re- placement bulbs	VW Part No.
Sealed beam (headlights) .....	6012	ZVP 118 112
Front turn signal/parking lights .....	1034	ZVP 118 034
Side marker lights .....	57	ZVP 118 057
Rear turn signal .....	1073	ZVP 118 073
Stop/tail lights .....	1034	ZVP 118 034
Back-up lights .....	1073	ZVP 118 073
License plate light (Volkswagen Type 3) ..	89	ZVP 118 089
License plate lights (Squareback Sedan) ...	67	ZVP 118 067
Instrument and warning lights .....	-	N 17 722 2
Warning lights for emergency flasher system, dual-circuit brake system, rear window defogger and Auxiliary Heater ..	-	N 17 751 2
Interior light, luggage compartment light (Type 3 only) .....	-	N 17 723 2
Selector lever console light (Automatic Trans- mission only) .....	-	N 17 751 2

## Replacing bulbs

### Headlights

Your Volkswagen is equipped with double filament seven inch sealed beam units. Should it become necessary to replace a unit, loosen screw in the center of the trim ring below the headlight and take off the rim ring:

Firmly grasp the loose screw (non-removable) and pull trim ring off.

Remove three short screws in sealed beam retaining ring and take ring off. Do not alter the position of the long headlight adjustment screws.

Take sealed beam unit out of support ring and pull cable connector off.

When installing new sealed beam units, be sure the three glass lugs engage properly in the support ring.



Before installing trim ring be sure the rubber gasket is in place. Loosely insert the screw for the trim ring and turn for 2 or 3 turns.

Position edge of trim ring over upper lug. Press ring over lug and tighten screw.

If no other headlight part as described here was removed or its position changed, it should not be necessary to aim the headlights. If in doubt have the adjustment checked at your dealer.



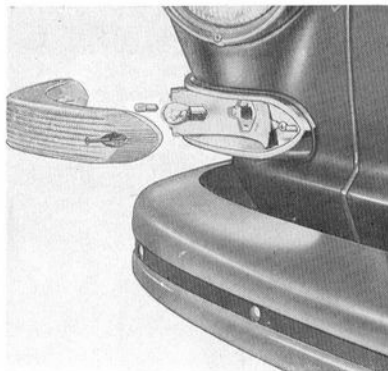

### **Front turn signal/parking light bulb or side marker light bulb**

Remove two Phillips screws.  
Take off lens.

Press bulb into holder lightly, turn and  
take out.

Install new bulb.

Be sure the gasket is properly posi-  
tioned when reinstalling the lens.

Tighten screws evenly. Do not over-  
tighten as this may crack the lens.

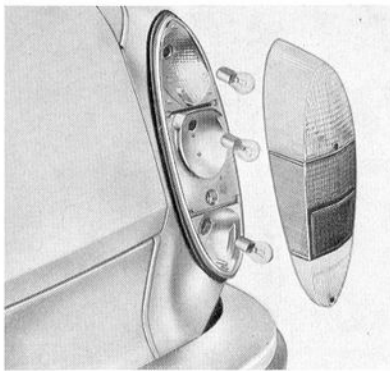

### **Rear turn signal, stop/tail light or back-up light bulb**

Unscrew two Phillips screws and re-  
move lens.

Bulb positions:

Top – turn signal light

Center – stop/tail light

Bottom – back-up light

Press bulb into holder lightly, turn and  
take out. Install new bulb.

When inserting the stop/tail light bulb,  
the retaining pin nearest to the bulb  
glass must be downward.

Be sure the gasket is properly posi-  
tioned when reinstalling the lens. Tigh-  
ten screws evenly. Do not overtighten  
as this may crack the lens.

## License plate light bulb

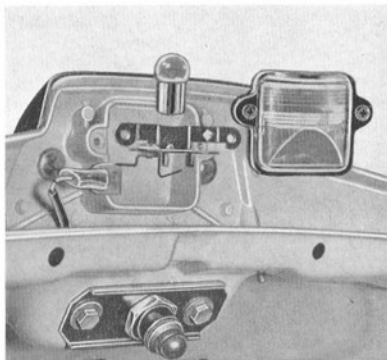

### 1 – Volkswagen Type 3

Open rear hood.

Remove screws on each side of lens and take off lens with bulb holder.

Pull bulb holder out of lens.

Press bulb into holder lightly, turn and take out.

Install new bulb.

When installing be sure that the cable connector fits properly.

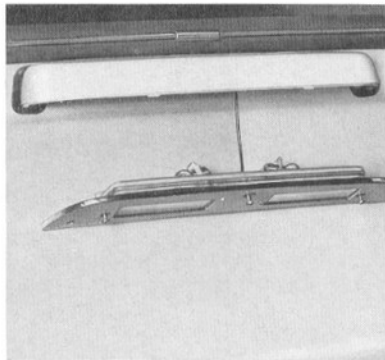

### 2 – Squareback Sedan

Open rear luggage compartment lid.

Loosen 3 Phillips screws so that you can remove the insert together with the bulb holder.

Press bulb lightly into holder. Turn and take out.

Install new bulb.

During re-assembly be sure that the rubber gasket is properly seated.

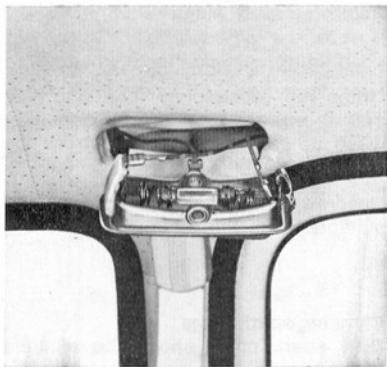

### **Interior light bulb**

Insert screwdriver at front behind the chromium plated frame and pry off carefully.

Take bulb out.

Install new bulb.

Insert housing at rear first, then press it in until retaining spring engages.

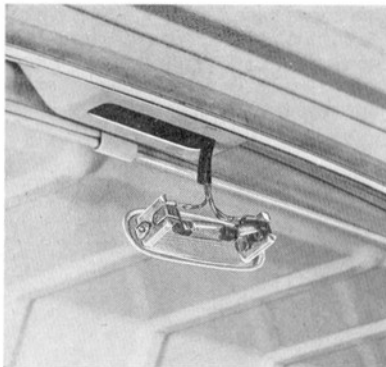

### **Rear luggage compartment light bulb** (for Volkswagen Type 3 only)

Open rear luggage compartment lid.

Insert screwdriver in lens cut-out on right side and carefully pry out. Exchange bulb.

insert on either side and press in.

## Cleaning or replacing spark plugs

The correct spark plug gap is .028 inch. Since the spark plug gap tends to increase in time during normal operation, it is advisable to replace spark plugs every 12,000 miles.



**Before working on any part in the engine compartment, turn off the engine and let it cool down sufficiently.**

### Removing spark plugs

If your car is equipped with an air conditioner, remove the air cleaner.

Grasp the spark plug connector and pull it off. Do not pull the ignition wires as they may separate from the connectors.

Unscrew the spark plugs with a suitable spark plug wrench.

### Cleaning spark plugs

Dirty spark plugs should be cleaned with a sand blaster, but if not available, the carbon can be removed with a wooden or plastic pick. Do not use a wire brush. The plugs should also be clean and dry on the outside to avoid shorting and arcing. **The gap can be set by bending the outside electrode. The gap should be .028 inch.**

### Installing park plugs

Insert them by hand and screw them into the cylinder head as far as they will go. Only then use the spark plug wrench to tighten them firmly. Do not overtighten.

## Checking the engine oil level

Your VW will usually not need additional oil between the scheduled changes.

Even so, you should check the oil level from time to time. To get a true reading, be certain the car is on level ground. Wait at least 5 minutes after the engine has been stopped; give the oil time to collect in the crankcase.

To check the oil level, take the dipstick out and wipe it clean first. Now, insert and pull it out again. You have enough oil in the engine if the oil level is between the upper and lower marks on the dipstick.

Only add the amount of oil that is needed.

Always select a well-known brand and the recommended grade. Details about the correct oil viscosities are on page 93.

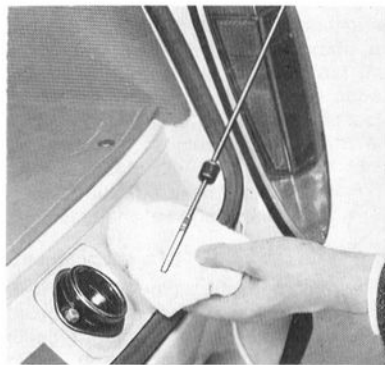

## Manual Transmission oil

Both transmission and final drive are combined in one housing. The lubricant used is hypoid oil that is changed by your dealer only one time at 600 miles as part of the lubrication service. See page 118.

The transmission is checked for leaks during the maintenance service. Should the need arise to replenish the oil filling, it should only be done with the necessary workshop equipment. Also hypoid oil is generally not marketed in small quantities.

## Automatic Transmission Fluid

### Checking the ATF level

The torque converter and the transmission are lubricated with Automatic Transmission Fluid (ATF). The final drive requires hypoid oil SAE 90 only. The ATF has to be checked every 6,000 miles. A correct ATF level is very important for the proper function-

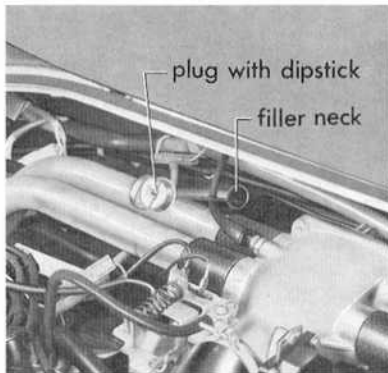

ing of the transmission. The reading should be done when the ATF is warm; with the engine idling, the selector lever in Neutral and the parking brake applied.

The ATF filler neck is in the engine compartment on the left hand side

above the air manifold pipes. The dipstick is attached to the plug. Pull it out and wipe it clean. The ring-shaped handle should be in the vertical position when reinserting the dipstick to measure the fluid level.

You have enough ATF if the fluid level is between the two marks on the dipstick. It should never be above or below these marks. If necessary, add ATF, but only as much as is needed, and have the transmission checked for possible leaks. Keep in mind that the difference between the lower and upper mark is only 0.85 U.S. pint (0.7 Imp. pt.). To add ATF, a clean funnel with an approximately 20 inch (50 cm) long hose should be used. For correct ATF specifications, see page 94.

### Changing the ATF

Every 30,000 miles the complete ATF filling has to be changed. The ATF filling should be changed every 18,000 miles under heavy duty conditions such as: trailer towing, continued stop-and-go traffic, extended mountain driving, and at extremely high outside temperatures.

**The car may not be towed and the engine should not be idling when there is no ATF in the transmission.**

## Air cleaner

A dirty cleaner element not only reduces the engine output, it can also cause premature engine wear. If local conditions are such that the vehicle is often driven on very dusty roads, the cleaner must be checked frequently, even daily if necessary.

All the dust present in the air drawn in by the engine is retained by the filter element in the upper part of the air cleaner and washed out by the oil in the lower part when the vehicle is in motion. In time, this forms a layer of sludge at the bottom of the lower part. When there is only  $\frac{3}{16}$  in. of oil above the sludge layer, the lower part must be cleaned and filled with fresh oil.

To accomplish this, the air cleaner must be removed:

Release clip – A – on intake pipe and pull belows from pipe.

Pull crankcase breather hose – B – off air cleaner intake pipe.

Pull hose – C – for auxiliary air control valve off air cleaner top part.

Loosen Phillips head screw – D – of clamp for elbow connector on intake air distributor.

Remove hose – J – of the activated charcoal filter in the fuel system.

Remove air cleaner after loosening wing screw – E –. Keep air cleaner in upright position to avoid spilling oil.

Release the two clips – F – and take off top part of cleaner. The top part must not be put down with the filter element upward.

Clean lower part of cleaner carefully.

Fill cleaner to mark with 0.85 U.S. pint (0.7 Imp. pt.) of fresh engine oil. SAE 30 oil should be used all the year except in areas with arctic climate where SAE 10 W oil should be used all year round.

The top part does not normally need cleaning. If the bottom part or the filter element has become so dirty that the air inlet holes on the underside are partly blocked, the encrusted dirt should be scraped off with a wood chip.

When assembling the cleaner note that the marks – G – on upper and lower parts are in line.

When installing the cleaner, ensure proper fit of bellows on intake pipe of air cleaner and elbow connector of intake air distributor.

Make sure the hose – J – for the activated charcoal filter is properly connected; interchanging of hoses affects the operation of the filter system.

Check that the weighted flap – H – of the crankcase ventilation moves freely.

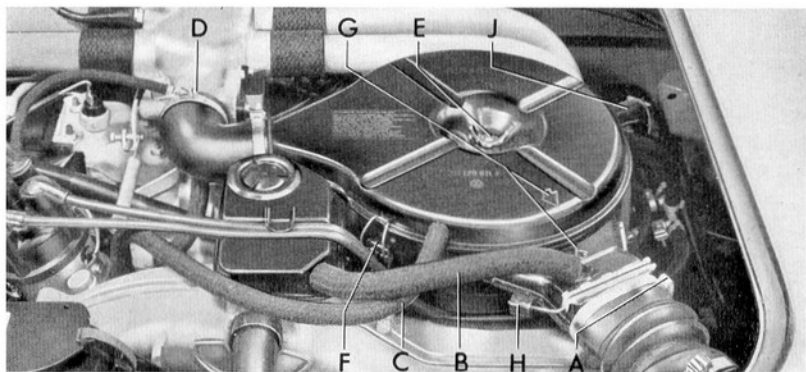



# Lubrication

## Front axle

Lubricate the front axle once a year or every 6,000 miles.

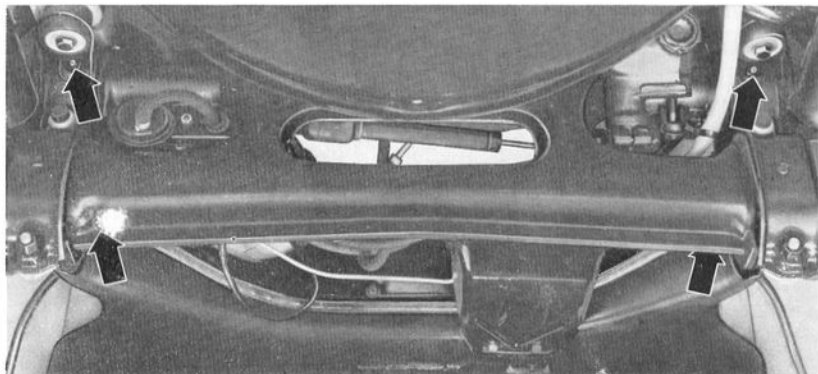

Lift the front end of the car to take the weight off the front wheels. This is necessary to free the bearings to accept the lubricant. There are 4 grease nipples for the front axle. For their location, see arrows in the illustration.

Before forcing grease into the nipples, be sure to wipe them clean with a piece of cloth. Force lithium-based multi-purpose grease into the nipples until fresh grease starts to emerge at the torsion arm sealing rings.

Wipe off any grease or oil that may have come in contact with tires or brake hoses because grease and oil have an adverse effect on rubber.

## Door hinges and locks

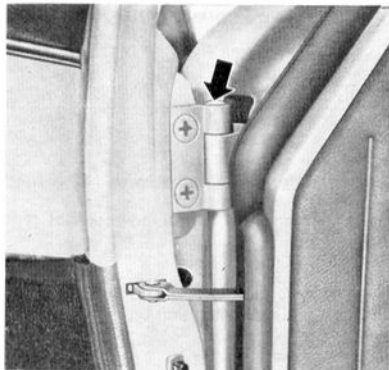

The **door hinges** should be lubricated every 3 months by filling a few drops of engine oil into the small oil chamber above every door hinge pin. The oil chamber is accessible after lifting the top plastic plug (arrow). After oiling, reinstall the plug and wipe off excess oil.



The **door locks** should also be lubricated with a few drops of engine oil through the hole above the lock. Remove the plastic plug first. Use an oil can with a fine nozzle.

Lubricate the **door lock cylinders** with graphite. Dip the key into graphite and turn it in the lock a few times.

Also, lubricate the **hood locks** and the sliding surfaces of the **striker plates** lightly with dry stick lubricant.

## When trouble troubles you

Your Volkswagen should repay you with trouble-free driving if it receives regular maintenance.

Should you ever encounter difficulty in starting your engine or have trouble on the road, there are a few simple repairs which you can make to get your VW going again. Locate the PROBLEM and PROBABLE CAUSE of the trouble in the guide on the following three pages and follow the directions on WHAT TO DO.

**Exercise extreme caution when working on any part of the car to prevent accidental injury. Incomplete or improper servicing may also cause problems in the operation of the car. If in doubt about any servicing, have it done by a qualified mechanic or by your Authorized VW Dealer.**

Note: The adjustment of idling and ignition timing requires special equipment. We suggest that you consult your Authorized Volkswagen Dealer.

PROBLEM	PROBABLE CAUSE	WHAT TO DO
VW will not start: engine will not turn over or turns over too slowly.	<ol style="list-style-type: none"><li>1. Run down or dead battery.</li><li>2. Loose connection<ol style="list-style-type: none"><li>A. At battery</li><li>B. At starter</li><li>C. At connector block on steering column under dashboard.</li><li>D. At light switch or fuse box.</li></ol></li><li>3. Starter defective.</li><li>4. On vehicles with Automatic Transmission: The selector lever is not in starting position.</li></ol>	<ol style="list-style-type: none"><li>1. Charge or replace battery.</li><li>2. Make sure that all connections are tight.<ol style="list-style-type: none"><li>A. Check both cable connections on battery and grounded end of ground strap.</li><li>B. Check connections at solenoid, mounted on starter, under right rear of vehicle.</li><li>C. Check push-on connectors for tightness.</li><li>D. Check push-on connectors at back of light switch and on fuse box.</li></ol></li><li>3. Ask for assistance.</li><li>4. Shift into Neutral or Park.</li></ol>
VW will not start: engine turns over.	<ol style="list-style-type: none"><li>5. Loose connection in ignition system.</li><li>6. Loose connection in primary circuit to coil.</li></ol>	<ol style="list-style-type: none"><li>5. Check for loose connections at coil, distributor and spark plugs.</li><li>6. Check push-on connector on coil (thin black wire). Check push-on connector on steering column of dashboard for tightness. Check connectors at fuse box. Should the engine not start, ask for assistance.</li></ol>

PROBLEM	PROBABLE CAUSE	WHAT TO DO
	<p>7. If spark is present at black coil cable, trouble is in ignition system.</p> <p>8. If spark is fairly good at plugs, trouble is most likely in fuel system.</p> <p>A. Caused by improper starting procedure.</p> <p>B. Engine flooded.</p> <p>C. Fuse for electrical fuel pump is blown.</p>	<p>7. Check in this sequence:</p> <p>A. Turn ignition off. Remove distributor cap and rotor. Clean distributor contacts with stiff paper (post card). Have someone start the engine. Sparks should be visible between contacts. If no spark, check contact of cable connectors between coil and distributor cap. Check if contacts open. If there is still no spark, see your nearest Authorized VW Dealer.</p> <p>B. If sparks are visible between contacts disconnect high tension cable from center connection of distributor cap. With starter cranking the engine point cable to a metal part of the engine leaving a gap of approximately <math>\frac{1}{4}</math>". Strong arching sparks should appear. If there are no sparks, contact your nearest Authorized VW Dealer.</p> <p>C. If sparks appear at high tension cable, the distributor cap should be cleaned inside and outside. Reconnect high tension cable. Remove all spark plugs. If plugs are clean and dry, reconnect ignition cables to spark plugs and bring spark plugs in connection with metal (ground). <b>Hold cable with dry piece of cloth to avoid shock.</b> Sparks should appear between spark plug electrodes when the engine is turned over. If not, clean and dry ignition cables and spark plug connectors and check that ignition cables are tight in distributor cap and plug connectors. Ask for assistance if the above steps did not ensure proper ignition.</p> <p>D. Dirty or wet spark plugs should be cleaned and dried. Install new plugs if necessary. Unburned gasoline on plug electrodes indicates excessive fuel supply.</p> <p>8. Check fuel system in the following sequence:</p> <p>A. Before turning on the ignition and starting the engine depress the accelerator pedal.</p> <p>B. Check all electrical connections in engine compartment. If engine still does not start, switch off the electrical fuel pump by taking fuse 7 out of the fuse box (see page 70). Depress accelerator pedal fully and start engine. Keep engine running until it stalls automatically. Install fuse and start engine as usual. If engine still does not start, ask for assistance.</p> <p>C. Replace fuse. If it blows again, ask for assistance.</p>

PROBLEM	PROBABLE CAUSE	WHAT TO DO
Engine stalls shortly after starting.	9. Poor fuel supply.	9. See paragraphs 11 and 12.
Engine stalls while vehicle is driven.	10. Defect in ignition system. 11. Fuel supply is exhausted. 12. Fuel filter may be clogged, gasoline may be contaminated by water or dirt.	10. See paragraph 5 through 7. 11. Check whether any gasoline is left in tank. 12. See your VW dealer for cleaning of all components of the fuel system.
Red warning light for oil pressure comes on while you are driving.	13. If light goes on, the oil pressure is too low.	13. Stop at once and check oil level. Add oil as necessary. If the oil level is sufficient and light goes on during driving, contact the nearest Authorized VW Dealer before driving on.
Red warning light for generator comes on while you are driving.	14. If light goes on, V-belt may be torn or slipping or generator does not charge.	14. Switch off all unnecessary electrical equipment (radio, etc.). Drive to nearest VW dealer as otherwise the battery will soon run down.

## Engine oil

Always use a name brand oil labeled "For Service MS" or "SD" for the engine of your Volkswagen.

Engine oils are graded according to their viscosity. The proper grade to be used in your engine depends on existing climatic or seasonal conditions.

The following table contains the grading for oils to be used in VW engines:

Tropical climate	Hot season		SAE 40
	Cool season		SAE 30
Moderate climate	Summer		SAE 20 W-20
	Winter	At average outside temperature of above 5 °F	SAE 20 W-20
		At average outside temperatures not lower than -13 °F	SAE 10 W *

If outside temperatures are continuously below -13 °F use SAE 5 W \*.

\* Avoid high speed long distance driving when using SAE 10 W or SAE 5 W if outside temperatures rise above the indicated limits.

As temperature ranges of the different oil grades overlap, **brief** variations in outside temperatures are no cause for alarm. It is also permissible to mix oil of different viscosities if you find it necessary to add oil.

Temperature ranges of SAE grades

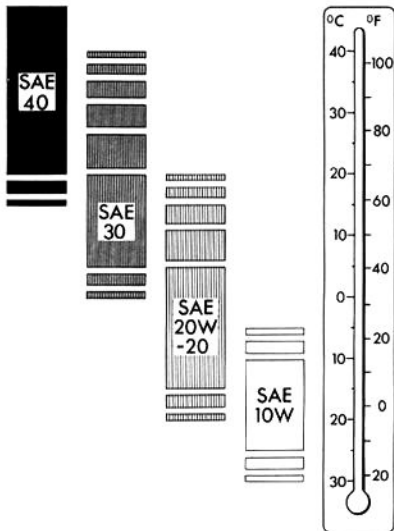

# Transmission oil and Automatic Transmission Fluid (ATF)

## A – Manual Transmission

Transmission and final drive are both lubricated with hypoid oil according to Mil – L – 2105 – B specifications (additive basis: sulphur-phosphorus):

SAE 90 In general all year round.

SAE 80 In areas with cold climate.

---

ATF In areas with arctic climate and temperatures consistently below  $-13^{\circ}\text{F}$ .

ATF is a special fluid for automatic transmissions, but ATF can also be used in the Manual Transmission under the above mentioned climatic conditions.

## B – Automatic Transmission

The final drive has to be lubricated only with hypoid oil SAE 90.

Automatic Transmission and torque converter require ATF all year round.

All ATF's labeled "Dexron<sup>®</sup>" with a five-digit number preceded by the letter "B" can be used.

## Lubricant additives

No additives should be mixed with fuel or lubricating oils and transmission fluids.

## Grease

1. **Multi-purpose grease with lithium base** should be used for the front axle.
2. **Dry stick lubricant** should be used for the hood locks and the sliding surfaces of the striker plates.
3. **Silicon spray or petroleum jelly** should be used for the battery terminals and posts.

# Engine with Manual Transmission

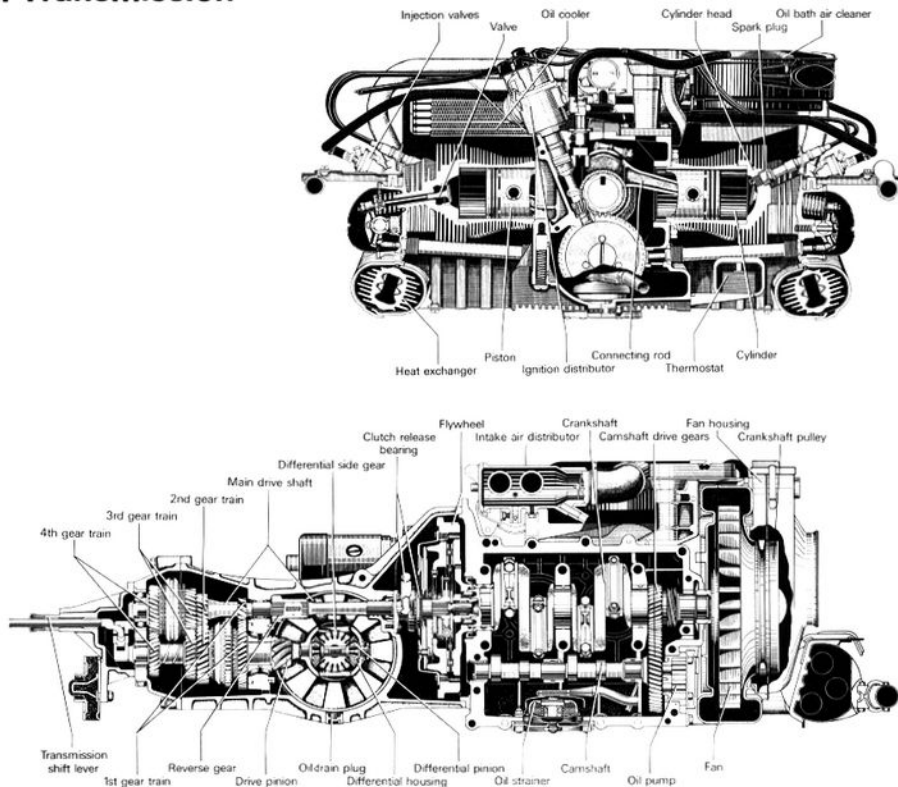



## Technical data

### Engine

Four cylinder, four stroke, horizontally opposed, flat design, in rear.

Thermostatically controlled air cooling by fan on crankshaft.

Pressure oil feed with gear-type pump. Oil cooler.

Electric fuel pump. Electronic fuel injection. Activated charcoal filter in the fuel system.

Bore .....	3.36 in. (85.5 mm)
Stroke .....	2.72 in. (69 mm)
Displacement .....	96.6 cu. in. (1584 cc.)
Valve clearance with engine cold .....	Intake and exhaust .004 in. (0.10 mm)
Compression ratio .....	7.3 : 1
Maximum torque SAE .....	86.8 ft. lbs. at 2800 rpm.
Fuel rating .....	91 octane (Regular incl. lead-free fuels)
Oil consumption .....	U.S. - 1.7 - 3.4 pints per 1000 miles Metric - 0.5 - 1.0 liter per 1000 km Imp. - 1.4 - 2.9 pints per 1000 miles

## Transmissions

### Automatic Transmission

Automatic transmission combined with final drive in one housing.

The transmission consists of a hydrodynamic torque converter and planetary gearing with three forward gears and one reverse.

Drive shafts with two constant velocity joints per shaft.

Planetary gear ratios:

1st gear	2.65 : 1
2nd gear	1.59 : 1
3rd gear	1.0 : 1
Reverse	1.8 : 1

Differential ratio: 3.67 : 1

### Manual Transmission

Single plate, dry clutch.

Clutch pedal free play: 0.4 – 0.8 in. (10 – 20 mm).

Baulk synchronized four-speed gearbox and bevel gear differential in one housing.

Drive shafts with two constant velocity joints per shaft.

Gear ratios:

1st gear	3.80 : 1
2nd gear	2.06 : 1
3rd gear	1.26 : 1
4th gear	0.88 : 1
Reverse	3.61 : 1

Differential ratio: 4.125 : 1

## Chassis

### General specifications

Platform frame with tunnel-shaped center member.

Front axle bolted to forked frame head, sub-frame at rear to carry engine-transmission unit. Independent wheel suspension: torsion arms at front, trailing arms and diagonal links at rear. Torsion bar springing, telescopic shock absorbers, stabilizer at front.

Roller steering (energy absorbing) with maintenance-free tie rods and hydraulic steering damper.

Footbrakes: Hydraulic, dual circuit system with discs at front and drums at rear.

Parking brake: Mechanical, effective on rear wheels.

Wheelbase .....	94.5 in. (2400 mm)
Turning circle .....	36.7 ft. (11.2 m)
Track at front .....	51.6 in. (1310 mm)
Toe-in .....	0.16 in. - 0.24 in. (4 to 6 mm) unladen
Camber .....	1° 20' ± 20' unladen
Track at rear .....	53.1 in. (1350 mm)
<b>Wheels</b> .....	4½ J x 15 safety rim wheels

Tires, tubeless

Bias Ply Tires

Volkswagen Type 3 .....

6.00-15 L/load capacity 1005 lbs. at 32 psi

Squareback Sedan .....

6.00-15 L/load capacity 1080 lbs. at 36 psi

**Tire pressures, cold**

front

rear

a - Volkswagen Type 3:

with 1 or 2 occupants .....

17 psi (1.2 kg/cm<sup>2</sup>)

26 psi (1.8 kg/cm<sup>2</sup>)

fully loaded .....

18 psi (1.3 kg/cm<sup>2</sup>)

29 psi (2.0 kg/cm<sup>2</sup>)

For long, high speed trips, the tire pressures should be increased by 3 psi (0.2 kg/cm<sup>2</sup>) at front and rear, but should not exceed the maximum tire inflation pressure listed on the tire label.

b - Squareback Sedan:

with half payload .....

17 psi (1.2 kg/cm<sup>2</sup>)

26 psi (1.8 kg/cm<sup>2</sup>)

with full payload .....

18 psi (1.3 kg/cm<sup>2</sup>)

36 psi (2.5 kg/cm<sup>2</sup>)



## Electrical system

Voltage .....	12 Volts
Battery .....	45 Ah
Starter .....	0.7 hp, with Automatic Transmission 0.8 hp
Generator .....	max. 360 watts, early cut in
V-belt size .....	9.1 or 9.5 x 1000 mm
Distributor .....	with combined vacuum and centrifugal spark advance
Firing order .....	1 - 4 - 3 - 2
Basic ignition timing .....	5° after TDC*
Contact breaker gap .....	0.016 in. (0.4 mm)
Spark plugs .....	Bosch W 145 T 1, Beru 145/14, Champion L 88 A or plugs with similar values from other manufacturers
Plug thread .....	14 mm
Electrode gap .....	0.028 in. (0.7 mm)

### \* 1 - Basic Adjustment

The engine should be at operating temperature. Take vacuum hoses for advance and retard spark off distributor. Adjust idling speed to 800-900 rpm. Set ignition timing to 5° before TDC.

### 2 - Final adjustment

Reconnect vacuum hoses. Adjust idling speed to 800-900 rpm. Ignition timing should now be at 5° ± 2° after TDC.

## Dimensions and weights

	Volkswagen Type 3	Volkswagen Squareback Sedan
Length .....	172.0 in. (4368 mm)	172.0 in. (4368 mm)
Width .....	63.2 in. (1605 mm)	63.2 in. (1605 mm)
Height .....	57.9 in. (1470 mm)	57.9 in. (1470 mm)
Ground clearance .....	5.9 in. ( 150 mm)	5.9 in. ( 150 mm)
Unladen weight .....	2226 lbs. (1010 kg)	2282 lbs. (1035 kg)
Vehicle capacity weight .....	775 lbs. ( 350 kg)	900 lbs. ( 410 kg)
Permissible total weight .....	3108 lbs. (1410 kg)	3274 lbs. (1485 kg)
Permissible front axle load .....	1278 lbs. ( 580 kg)	1278 lbs. ( 580 kg)
Permissible rear axle load .....	1874 lbs. ( 850 kg)	2072 lbs. ( 940 kg)
Permissible roof and trailer weights:		
Roof weights ** .....	165 lbs. ( 75 kg)	165 lbs. ( 75 kg)
Trailer without brakes .....	1025 lbs. ( 465 kg)	1080 lbs. ( 490 kg)

\*\* Applies only to roof rack mounted to rain gutters. Distribute load evenly!

## Capacities

Fuel tank .....	10.6 U.S. galls (8.8 Imp. galls; 40 liters)
Engine .....	5.3 U.S. pints of engine oil (2.5 liters; 4.4 Imp. pints)
Transmission and final drive .....	6.3 U.S. pints of hypoid oil (3 liters; 5.3 Imp. pints), refill with 5.3 U.S. pints (2.5 liters; 4.4 Imp. pints)
On vehicles with Automatic Transmission:	
Torque converter and planetary gears .....	Approx. 12.7 U.S. pints (6 liters; 10.6 Imp. pints) ATF, refill with 6.3 U.S. pints (3.5 liters; 5.3 Imp. pints)
Final drive .....	Approx. 2 U.S. pints (1 liter; 1.8 Imp. pint) Hypoid oil SAE 90
Brakes .....	0.53 U.S. pint of brake fluid (0.25 liter; 0.44 Imp. pint)
Oil bath air cleaner .....	Approx. 0.85 U.S. pint engine oil (0.40 liter; 0.70 Imp. pint)
Container for windshield washer .....	Approx. 3.5 U.S. pints (3.0 Imp. pints; 1.7 liter) of fluid operating pressure: Type 3                      42 psi (3 kg/cm <sup>2</sup> ) Squareback Sedan    56 psi (4 kg/cm <sup>2</sup> )

## Performance

	Manual Transmission	Automatic Transmission
Maximum and cruising speed	84 mph. (135 kph.)	81 mph. (130 kph.)
Acceleration time from		
0-50 mph. (0-80 kph.) ....	approx. 11.5 seconds	approx. 14 seconds
0-62 mph. (0-100 kph.) ...	approx. 18.0 seconds	approx. 24 seconds

**In any authorized VW dealer's service department, you get VW Specialists who know VW's intimately.**

A VW Specialist works on VW's. Period.

Every so often he takes time off and gets a refresher course at one of our VW training centers.

So he learns to fix Volkswagens before he starts working on your car. Rather than while he is working on your car. We think it is better that way.



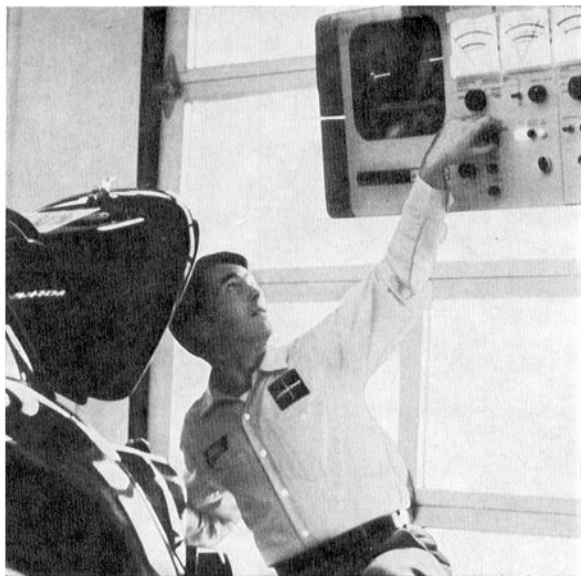

**Authorized VW Dealers use a new service system specially developed for the VW.**

Lots of service stations say they can repair Volkswagens and a lot of them really can.

But they cannot offer you VW Diagnosis and Maintenance — our new service system.

Instead of giving every VW the same basic maintenance, we now treat each one as an individual.

And we have already prepared your car for our even more advanced diagnosis system of the future. The plug in the engine compartment is a part of this future.

Specially trained diagnosticians will check your VW directly using special testing equipment; that means your car gets just the maintenance it needs. No more, no less.

And you get a test report so you know the exact condition of your VW.

It tells you a lot about the car you drive.



## Volkswagen Diagnosis and Maintenance

has been designed especially for today's Volkswagen and today's driving conditions.

Instead of giving every VW the same basic maintenance, we treat each one as an individual. (Because you are the driver. And you have your own individual driving habits.)

Here is how it works:

When you bring your VW in for service you will see the service adviser as usual. But your car won't go to the mechanic as usual. Instead it will be driven into a special diagnosis stall. One that is equipped with the very latest testing devices, especially designed for Volkswagen.

There, your VW will be tested by a specially trained Diagnostician.

He will check your car from bumper to bumper. He will analyze the engine. Check the wheel alignment, brakes, transmission. The lights, the battery, the tires. And many other items.

All in all, he will make dozens of tests.

And he will fill out a Test Report, like the one shown on the following two pages. You will get a copy of this Test Report. So you will know the condition of your VW.

If your VW is in good shape, you will know it. If any repairs or adjustments are required, you will know what needs to be done now, and what should be taken care of in the near future.

While your VW is at the dealership, your Volkswagen dealer can also perform the essential services, such as oil change, lubrication and other adjustment every VW requires.

The important thing is to bring your VW in for regular, periodic checkups.

So check the mileage chart on pages 109–117. Then keep an eye on your odometer. When your VW is due for service, bring it to your dealer. With VW Diagnosis and Maintenance, he can give your Volkswagen exactly the service it needs.

No more. No less.

Can you think of a better way?

Factory-recommended VW Maintenance.

This Test Report tells you what work, if any, should be performed on your particular vehicle.

In addition, your Volkswagen should have VW Maintenance at specific mileages, as shown below.

This factory-recommended VW Maintenance can be done when your car is in for VW Diagnosis.

And it should be done. Every 6000 miles. To keep your VW running like a VW.

Every 6,000 miles

- Door and hood locks: Lubricate.
- Engine: Change oil and clean oil strainer.
- Front end: Lubricate.
- Air cleaner: Clean, if necessary, and fill lower part with oil.
- Valves: Check and adjust clearance.
- Distributor: Lubricate.
- Transmission and final drive: Check oil level.
- Automatic Stick Shift or vehicles equipped with automatic transmission: Check ATF level.
- Test Drive: Check braking, steering, heating, ventilation system and overall performance.
- Cylinder head covers: Check for leaks.

Every 12,000 miles

The 6,000 Mile Maintenance items are performed, plus the following services:

- Contact points: Replace, adjust dwell and timing with stroboscopic light.
- Spark Plugs: Replace.

Depending upon the model VW you own, there may be additional services required. See your VW Maintenance Record for details.

Keep this Test Report with your VW Maintenance Record. A pocket has been provided in the front cover for this purpose.



# Volkswagen Diagnosis and Maintenance

## Test report.





This page was  
originally left Blank

## VW Diagnosis and Maintenance Record

The VW Diagnosis and Maintenance Service has been developed to give you maximum economy, dependability, safety and convenience. The Diagnosis and Maintenance Record, which appears on the following pages (pages 109–117) shows you at what mileage you should bring your car to your Authorized Volkswagen Dealer.

Naturally, this may not be the only maintenance your car needs, but you will know what additional maintenance is needed when you receive a copy of the VW Diagnosis Test Report. Just hand this Volkswagen Owner's Manual to your Authorized Volkswagen Dealer. He will do the rest.

Remember, from 6,000 miles onward, the VW Diagnosis and Maintenance service should be performed every 6,000 miles. Engine oil should be changed every 3,000 miles.

If your Volkswagen is driven less than 3,000 miles in three months, have the oil changed every three months; if driven less than 6,000 miles in twelve months, have the front end lubricated once a year.

Of course, you can obtain a VW Diagnosis at any time — outside the regular schedule — at your Authorized Volkswagen Dealer. Especially if you drive less than 6,000 miles a year, we recommend you have a VW Diagnosis performed between regular mileage intervals.

Every Authorized Volkswagen Dealer at home or abroad will perform all the operations listed for VW Diagnosis, VW Maintenance, and the additional services (such as oil change, lubrication, brake fluid renewal, repacking of wheel bearings), in accordance with Volkswagen quality service standards.

To get you started, there is a booklet with VW Diagnosis Coupons in the back cover pocket of this manual.

The first of these coupons entitles you to a free maintenance and oil change service. The next four coupons enable you to obtain one free VW Diagnosis each. The remaining coupons serve as a reminder to bring your Volkswagen in for a VW Diagnosis and Maintenance at regular intervals.

The free coupons are not transferrable; they are only valid for **your** Volkswagen. Do not remove them from the coupon booklet which shows the chassis number of your car.

<b>Delivery Inspection</b>	<b>600 miles</b>	
	<b>Engine and Transmission Oil Change</b>	<b>Free Maintenance Service</b>
(Dealer Stamp)	(Dealer Stamp)	(Dealer Stamp)
Date _____	Date _____	Date _____
Miles _____	Miles _____	Miles _____

<b>3 000 miles</b>	<b>6 000 miles</b>	<b>6 000 miles</b>	<b>9 000 miles</b>	<b>12 000 miles</b>	<b>12 000 miles</b>
<b>Oil Change Service</b>	<b>Free Diagnosis</b>	<b>Maintenance</b>	<b>Oil Change Service</b>	<b>Free Diagnosis</b>	<b>Maintenance</b>
(Dealer Stamp)	(Dealer Stamp)	(Dealer Stamp)	(Dealer Stamp)	(Dealer Stamp)	(Dealer Stamp)
Date _____	Date _____	Date _____	Date _____	Date _____	Date _____
Miles _____	Miles _____	Miles _____	Miles _____	Miles _____	Miles _____

This page was  
originally left Blank

<b>15 000 miles</b>	<b>18 000 miles</b>	<b>18 000 miles</b>	<b>21 000 miles</b>	<b>24 000 miles</b>	<b>24 000 miles</b>
<b>Oil Change Service</b>	<b>Free Diagnosis</b>	<b>Maintenance</b>	<b>Oil Change Service</b>	<b>Free Diagnosis</b>	<b>Maintenance</b>
(Dealer Stamp)	(Dealer Stamp)	(Dealer Stamp)	(Dealer Stamp)	(Dealer Stamp)	(Dealer Stamp)
Date _____	Date _____	Date _____	Date _____	Date _____	Date _____
Miles _____	Miles _____	Miles _____	Miles _____	Miles _____	Miles _____
<b>27 000 miles</b>	<b>30 000 miles</b>	<b>30 000 miles</b>	<b>33 000 miles</b>	<b>36 000 miles</b>	<b>36 000 miles</b>
<b>Oil Change Service</b>	<b>Diagnosis</b>	<b>Maintenance</b>	<b>Oil Change Service</b>	<b>Diagnosis</b>	<b>Maintenance</b>
(Dealer Stamp)	(Dealer Stamp)	(Dealer Stamp)	(Dealer Stamp)	(Dealer Stamp)	(Dealer Stamp)
Date _____	Date _____	Date _____	Date _____	Date _____	Date _____
Miles _____	Miles _____	Miles _____	Miles _____	Miles _____	Miles _____
<b>39 000 miles</b>	<b>42 000 miles</b>	<b>42 000 miles</b>	<b>45 000 miles</b>	<b>48 000 miles</b>	<b>48 000 miles</b>
<b>Oil Change Service</b>	<b>Diagnosis</b>	<b>Maintenance</b>	<b>Oil Change Service</b>	<b>Diagnosis</b>	<b>Maintenance</b>
(Dealer Stamp)	(Dealer Stamp)	(Dealer Stamp)	(Dealer Stamp)	(Dealer Stamp)	(Dealer Stamp)
Date _____	Date _____	Date _____	Date _____	Date _____	Date _____
Miles _____	Miles _____	Miles _____	Miles _____	Miles _____	Miles _____



This page was  
originally left Blank

<b>51 000 miles</b> <b>Oil Change Service</b>  (Dealer Stamp)  Date _____ Miles _____	<b>54 000 miles</b> <b>Diagnosis</b>  (Dealer Stamp)  Date _____ Miles _____	<b>54 000 miles</b> <b>Maintenance</b>  (Dealer Stamp)  Date _____ Miles _____	<b>57 000 miles</b> <b>Oil Change Service</b>  (Dealer Stamp)  Date _____ Miles _____	<b>60 000 miles</b> <b>Diagnosis</b>  (Dealer Stamp)  Date _____ Miles _____	<b>60 000 miles</b> <b>Maintenance</b>  (Dealer Stamp)  Date _____ Miles _____
<b>63 000 miles</b> <b>Oil Change Service</b>  (Dealer Stamp)  Date _____ Miles _____	<b>66 000 miles</b> <b>Diagnosis</b>  (Dealer Stamp)  Date _____ Miles _____	<b>66 000 miles</b> <b>Maintenance</b>  (Dealer Stamp)  Date _____ Miles _____	<b>69 000 miles</b> <b>Oil Change Service</b>  (Dealer Stamp)  Date _____ Miles _____	<b>72 000 miles</b> <b>Diagnosis</b>  (Dealer Stamp)  Date _____ Miles _____	<b>72 000 miles</b> <b>Maintenance</b>  (Dealer Stamp)  Date _____ Miles _____
<b>75 000 miles</b> <b>Oil Change Service</b>  (Dealer Stamp)  Date _____ Miles _____	<b>78 000 miles</b> <b>Diagnosis</b>  (Dealer Stamp)  Date _____ Miles _____	<b>78 000 miles</b> <b>Maintenance</b>  (Dealer Stamp)  Date _____ Miles _____	<b>81 000 miles</b> <b>Oil Change Service</b>  (Dealer Stamp)  Date _____ Miles _____	<b>84 000 miles</b> <b>Diagnosis</b>  (Dealer Stamp)  Date _____ Miles _____	<b>84 000 miles</b> <b>Maintenance</b>  (Dealer Stamp)  Date _____ Miles _____

This page was  
originally left Blank

<b>87 000 miles</b>	<b>90 000 miles</b>	<b>90 000 miles</b>	<b>93 000 miles</b>	<b>96 000 miles</b>	<b>96 000 miles</b>
<b>Oil Change Service</b>	<b>Diagnosis</b>	<b>Maintenance</b>	<b>Oil Change Service</b>	<b>Diagnosis</b>	<b>Maintenance</b>
(Dealer Stamp)	(Dealer Stamp)	(Dealer Stamp)	(Dealer Stamp)	(Dealer Stamp)	(Dealer Stamp)
Date _____	Date _____	Date _____	Date _____	Date _____	Date _____
Miles _____	Miles _____	Miles _____	Miles _____	Miles _____	Miles _____

<b>99 000 miles</b>	<b>100 000 miles</b>	<b>100 000 miles</b>
<b>Oil Change Service</b>	<b>Diagnosis</b>	<b>Maintenance</b>
(Dealer Stamp)	(Dealer Stamp)	(Dealer Stamp)
Date _____	Date _____	Date _____
Miles _____	Miles _____	Miles _____

This page was  
originally left Blank

## Additional Services Record

The boxes on this page indicate services that are required in addition to the preceding Maintenance schedule.

Be sure to have all service items performed — at the recommended mileages or dates — by an Authorized Volkswagen Dealer.

It is the best way to keep your VW running. And running. And running.

<b>30 000 miles</b>	<b>60 000 miles</b>	<b>90 000 miles</b>
<b>Repack front and rear wheel bearings ATF Change</b>	<b>Repack front and rear wheel bearings ATF Change</b>	<b>Repack front and rear wheel bearings ATF Change</b>
(Dealer Stamp)	(Dealer Stamp)	(Dealer Stamp)
Date _____	Date _____	Date _____
Miles _____	Miles _____	Miles _____

ATF (Automatic Transmission Fluid) changes apply to vehicles equipped with automatic transmission.

### Important:

Change ATF every 18,000 miles if vehicle is operated under heavy duty conditions such as trailer towing, high outside temperatures, continuous mountain driving or constant stop and go traffic. If in doubt, consult your Authorized Volkswagen Dealer.

<b>Brake Fluid Renewal and checking of brake warning light switch</b>		
<b>after 2 years of operation</b>	<b>after 4 years of operation</b>	<b>after 6 years of operation</b>
(Dealer Stamp)	(Dealer Stamp)	(Dealer Stamp)
Date _____	Date _____	Date _____
Miles _____	Miles _____	Miles _____

## Oil Change and Maintenance Service 600 Miles

The free maintenance service at 600 miles consists of the following: (Lubricants, fluid and materials such as gaskets are paid by the customer).

### Oil Change

- 1 – Engine: Change oil, clean oil strainer. Check for leaks.
  - 2 – Manual Transmission: Change oil, clean magnetic drain plugs. Check for leaks.
- On vehicles with Automatic Transmission:
- 3 – Check torque of bolts on fluid pan.

### Maintenance Service

- 1 – V-Belt: Check, adjust if necessary.
- 2 – Valve clearance: Check and adjust.
- 3 – Clutch pedal free play: Check and adjust.
- 4 – Rear axle: Check torque of bolts on constant velocity joints.
- 5 – Drive shafts: Check boots for leaks.
- 6 – Front axle: Check tie rod ends and tie rods.
- 7 – Tires and wheels: Check tire pressures, including spare wheel. Check wheel bolts, torque to factory specifications if necessary.
- 8 – Brake system: Check for damage and leaks. Check brake fluid level, add if necessary. Adjust foot and parking brakes.
- 9 – Electrical system: Check operation of all components, adjust headlights if necessary.

### During roadtest:

Check efficiency of braking, steering, heating and ventilation systems. Check overall performance.

### After roadtest:

Check and adjust idling. Check cylinder head covers for leaks.

# VW Diagnosis and Maintenance

## Oil Change Service

The engine in the Volkswagen requires little oil. But for long engine life, this oil should be changed every 3,000 miles. An oil change at a VW dealer includes the services shown below:

- 1 – Engine: Change oil, clean oil strainer, check for leaks.
- 2 – Battery: Check, add distilled water if necessary. Clean and grease terminals.
- 3 – Windshield washer: Check fluid.

## VW Diagnosis

A physical checkup of your VW is extremely important for determining the amount of additional maintenance your vehicle may need for continuing peak performance.

Listed on the following pages is the VW Diagnosis procedure which applies to your vehicle.

Chances are, if you have regularly maintained your vehicle, it is in good running condition.

The VW Diagnosis Test Report will be given to you so you will know the exact condition of your VW.

It is something you should know.

## A VW Diagnosis every 6,000 miles consists of:

(only applicable operations on your vehicle will be performed)

### Engine and clutch:

- 1 – V-Belt: Check tension and condition.
- 2 – Ignition system: Check with electronic equipment.
- 3 – Compression: Check, including remove and install spark plugs. Note: Replace plugs at 12,000, 24,000, 36,000 miles etc.
- 4 – Water drain flaps and air intake housing bellows: Check.
- 5 – Exhaust system: Check for damage.
- 6 – Manual Transmission  
Clutch: Check pedal free play.
- 7 – Engine: Check oil level.
- 8 – Engine: Check for leaks.
- 9 – Idling: Check and adjust.

### Rear axle and transmission:

- 10 – Drive shaft boots: Check for leaks.
- 11 – Rear axle, final drive and transmission: Check for leaks.
- 12 – Automatic Transmission  
Fluid pan: Check torque of bolts.
- 13 – Automatic Transmission  
Torque converter system: Check for leaks.
- 14 – Automatic Transmission  
Kickdown: Check for correct functioning.



### **Front axle and steering:**

- 15 – Front axle: Check dust seals and proper fit of plugs on ball joints, check dust seals on tie rod ends, check tie rods.
- 16 – Upper torsion arms: Check play.
- 17 – Ball joints: Check play.
- 18 – Steering: Check play.
- 19 – Front wheels: Check camber and toe.

### **Brakes, wheels, tires:**

- 20 – Brakes: Check brake system for damage and leaks.
- 21 – Brake pedal: Check free play.
- 22 – Brake pedal: Check pedal travel.
- 23 – Parking brake: Check adjustment.
- 24 – Brake fluid: Check level.
- 25 – Brake linings or pads: Check thickness.
- 26 – Tires, including spare wheel: Check for wear and damage, check and correct pressure.
- 27 – Wheels: Check torque of mounting bolts.

### **Electrical system:**

- 28 – Cranking system: Check with electronic equipment.
- 29 – Charging system: Check with electronic equipment.
- 30 – Check operation of headlights, parking lights, side marker lights, license plate light, interior light, emergency lights, ignition lock, buzzer alarm, stop lights, back-up lights, turn signal lights, horn, instrument lights, fresh air fan and warning lights for brakes, oil pressure, generator and rear window defogger.
- 31 – Headlights: Check and adjust.
- 32 – Windshield wiper: Check operation and blades.
- 33 – Windshield washer: Check operation and fluid.
- 34 – Battery: Check electrolyte level, add distilled water if necessary, check voltage under load.

### **Test Drive**

Test drive if Diagnosis is not followed by maintenance or repair. If maintenance or repair follow the diagnosis, test drive after the job is completed.

Check braking, clutch, steering, heating, ventilation system and overall performance.

**The "National Traffic & Motor Vehicle Safety Act of 1966" requires manufacturers to be in a position to contact vehicle owners if a correction of a product defect becomes necessary.**

Please fill in one of the attached postcards if you change your address or purchase a Used Volkswagen.

You need not use this card if you purchased your car through an Authorized Volkswagen Dealer.

Please quote the VW chassis number as it appears on the identification plate of the vehicle. Its location is shown on page 15. Do not use the abbreviated serial number as shown on the vehicle registration.

Additional cards can be obtained from any Authorized Volkswagen Dealer.

**NOTICE OF ADDRESS CHANGE**  
**NOTICE OF USED CAR PURCHASE**

please check one of the above boxes

VW Chassis Number

Mo. Day Yr.

Last Name

First Name

Initial

Number

Street

City

State

Zip Code

Please print and give complete information.

## Delivery Inspection

Checklist for \_\_\_\_\_

(chassis number)

### Before Roadtest

#### Engine

Oil level

#### Chassis

Wheel bolts

Tire pressures (including spare wheel)

Brake fluid reservoir

Brake lines and hoses

Steering components

Engine and transmission for leaks

#### Electrical system

Battery

Headlight dimmer switch

Ignition/steering lock

Headlight adjustment

Tail and stop lights

Licence plate light

Instrument lights

Turn signal and parking lights

Emergency flasher lights

Back-up lights

Horn

Windshield wipers and washer

Warning lights

Generator

Oil pressure

Turn signals

High beam

Brakes

Emergency flasher

**BUSINESS REPLY MAIL**  
No Postage Stamp Necessary if Mailed in the United States

POSTAGE WILL BE PAID BY

**VOLKSWAGEN of AMERICA, Inc.**

818 Sylvan Avenue

Englewood Cliffs, N. J. 07632

FIRST CLASS  
Permit No. 785  
Englewood, N. J.  
07631

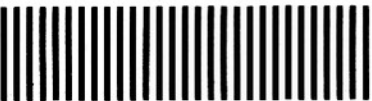

**During Roadtest**

Foot and parking brake  
Gear shifting and clutch  
Windshield defroster  
Speedometer

**After Roadtest**

Idling adjustment  
Operation of seat adjustment  
Safety belts  
Door locks  
Door hinges

Remarks: \_\_\_\_\_

Vehicle in perfect condition \_\_\_\_\_

\_\_\_\_\_

(Signature of Service Adviser/Date)

**NOTICE OF ADDRESS CHANGE**

**NOTICE OF USED CAR PURCHASE**

please check one of the above boxes

VW Chassis Number

Mo. Day Yr.

Last Name

First Name

Initial

Number

Street

City

State

Zip Code

Please print and give complete information.

**NOTICE OF ADDRESS CHANGE**

**NOTICE OF USED CAR PURCHASE**

please check one of the above boxes

VW Chassis Number

Mo. Day Yr.

Last Name

First Name

Initial

Number

Street

City

State

Zip Code

Please print and give complete information.

**BUSINESS REPLY MAIL**  
No Postage Stamp Necessary if Mailed in the United States

POSTAGE WILL BE PAID BY

**VOLKSWAGEN of AMERICA, Inc.**

818 Sylvan Avenue

Englewood Cliffs, N. J. 07632

FIRST CLASS  
Permit No. 785  
Englewood, N. J.  
07631

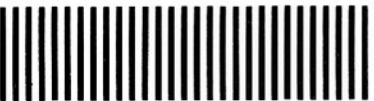

**BUSINESS REPLY MAIL**  
No Postage Stamp Necessary if Mailed in the United States

POSTAGE WILL BE PAID BY

**VOLKSWAGEN of AMERICA, Inc.**

818 Sylvan Avenue

Englewood Cliffs, N. J. 07632

FIRST CLASS  
Permit No. 785  
Englewood, N. J.  
07631

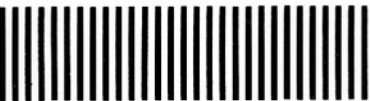

# Index

- Acceleration ..... 32, 33, 35  
Accelerator — kickdown ..... 35  
    — pedal ..... 32  
Air cleaner ..... 86  
Air conditioner ..... 50  
Anti-freeze ..... 56, 69, 74  
Ashtrays ..... 39  
Assist straps ..... 39  
Assisthandle ..... 22, 23  
ATF (Automatic Transmission Fluid) ..... 56, 85, 94  
Automatic Transmission ..... 34  
Auxiliary heater ..... 52  
**Back-up lights** ..... 33, 79  
Battery ..... 55, 72  
Brakes ..... 29, 32  
Brake — fluid reservoir ..... 69  
    — warning light ..... 23, 29  
Bulb — chart ..... 78  
    — replacing ..... 78  
Buzzer ..... 16, 24  
Carpet cleaning ..... 76  
Chassis — care ..... 75  
    — number ..... 15  
Chrome care ..... 75  
Cleaning your VW ..... 74  
Clock ..... 23, 25  
Cloth upholstery ..... 76  
Clutch ..... 32  
Coat hooks ..... 39  
Defogger, rear window ..... 23, 30  
Defogging and defrosting ..... 47  
Defroster/heater ..... 46  
Diagnosis and maintenance ..... 103  
    — Additional service ..... 117  
    — Mileage chart ..... 109  
    — Scheduled Maintenance ..... 118  
    — Test report ..... 104  
Dimmer switch lever ..... 23, 26  
Dipstick ..... 83, 85  
Distributor addresses ..... 130  
Driving ranges  
    — Automatic Transmission ..... 35  
    — Manual Transmission ..... 33  
Doors ..... 17  
Economical driving ..... 32  
Emergency — equipment ..... 55  
    — flasher ..... 23, 28  
Engine — compartments ..... 42, 45  
    — number ..... 15  
    — type of oil ..... 56, 93  
    — oil level ..... 83  
    — sectional view ..... 95  
Fan, fresh air ..... 49  
Fuel — gauge ..... 23, 25  
    — injection ..... 37  
    — octane rating ..... 73, 96  
    — supply and tank ..... 73, 100  
Fuses ..... 70  
Gearshift lever ..... 33  
Generator warning light ..... 25, 27  
Glove compartment ..... 40  
Grease ..... 94  
**Headlight** — sealed beam ..... 78  
    — switch ..... 23, 28  
    — dimmer lever ..... 23, 26  
Heating ..... 46, 52  
Hood ..... 41  
Horn ..... 23  
Hub cap ..... 65, 68  
Identification plate ..... 15  
Ignition/steering lock ..... 24  
Indicator lights ..... 25  
Instrument — illumination ..... 28  
    — panel ..... 22  
Interior light ..... 39  
**Jack** ..... 62  
Jack ports ..... 63, 66  
**Keys** ..... 16  
Lane changer ..... 26  
Leatherette cleaning ..... 76  
License plate light ..... 28, 80  
Lights ..... 23, 28, 78  
Locking knob ..... 17  
Locks ..... 17, 55  
Lubricants ..... 94  
Lubrication — door hinges and locks ..... 89  
    — front axle ..... 88  
Luggage compartments ..... 40  
    — light (Type 3) ..... 42, 81  
    — Squareback ..... 43  
    — Type 3 ..... 42

Manual Transmission	32, 85, 97	Snow tires	60	— weights	99
Maintenance, Diagnosis and	103	Spare tire	58, 61, 69	— wheels	98
Neutral	24, 33, 34, 90	Spark plugs	56, 82, 99	Tires and pressures	57–60, 98
Octane rating	73, 96	Specifications		Torque adjustment	58, 68
Odometer	25	— (Technical data)	96	Touch-up	75
Oil — dipstick	83	Speedometer	23, 25	Towing	54
— engine	56, 83, 84, 93	Speed ranges		Trailer hauling	53
— pressure warning light	25, 27	— Automatic Transmission	35	Transmission	
— transmission	56, 85, 94	— Manual Transmission	33	— Automatic	34, 85, 97
Parking,		Spot removing	76	— Manual	32, 85, 97
Automatic Transmission	36	Squareback Sedan	43	— oil	56, 85, 94
Parking — brake	33	Starting	24, 36, 37	Troubleshooting	90
— lights	25, 28, 79	Steering column lock	24	Trip odometer	25
Polishing	75	Stop light	79	Turn signals	23, 25, 26, 79
Push-starting	36	Straps, assist	39	Vanity mirror	38
Rear view mirrors	31	Studded tires	60	Vehicle identification	15
Rear window defogger	30	Sun roof	38	Ventilation	48–49
Reverse		Sun visors	38	Warning lights	25
— Automatic Transmission	34, 35	Tail lights	28, 79	Warranty	7–11
— Manual Transmission	33	Technical data	96–100	Waxing	75
Safe driving hints	13	— capacities	100	Weatherstrips	75
Safety — belts	20	— chassis, gen. specs.	98	Wheel — balancing	58
— compliance sticker	14	— differential ratio	97	— changing	63–68
Seats — adjustment	18, 77	— dimensions	99	Windows	18
— belts	20	— electrical system	99	Windshield	
— removing and installing	77	— engine	96	— washer fluid	
Selector lever, Automatic	34	— fuel octane rating	96	and container	56, 61, 69
Shifting	33–36	— gear ratios	97	— wiper blades	75
Side marker lights	28, 79	— oil consumption	96	— wiper/washer lever	26
Sliding roof	38	— performance	100	Winter — operation	55–56
		— tires and pressures	98	— starting	37
		— transmissions	97		



### **Owner Relations**

There are more than 1,500 authorized Volkswagen dealers in North and Central America. Their addresses and telephone numbers are listed in a booklet which is available at your VW Dealer.

Any one of these dealers is well equipped to help you with virtually all VW-related matters; and your dealer should be your primary source.

Should there be an occasion where you need further assistance, you may want to contact your area distributor. We show the addresses and telephone numbers of the VW distributors in the U. S. on the next page.

However, remember that ultimately your questions will be resolved in the dealership with dealer personnel and dealer equipment. We therefore suggest you contact your dealer first.

For quick reference, always include chassis number in correspondence.

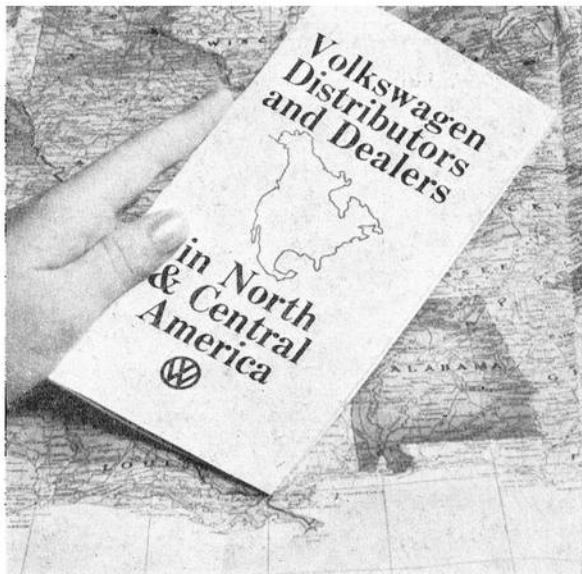

### Addresses of VW Distributors in the US:

<b>Maine</b>	Volkswagen Northeastern	<b>Connecticut</b>	World-Wide Volkswagen Corporation
<b>Massachusetts</b>	Distributor, Inc.	<b>New York</b>	Greenbush Road
<b>New Hampshire</b>	100 Fordham Road	<b>New Jersey</b>	Orangeburg, New York 10962
<b>Rhode Island</b>	Wilmington, Massachusetts 01887		(914) 359-5000
<b>Vermont</b>	(617) 658-6700	<b>Washington, D.C.</b>	Volkswagen South Atlantic
<b>Illinois</b>	Volkswagen North Central	<b>Maryland</b>	Distributor, Inc.
<b>Iowa</b>	Distributor, Inc.	<b>North Carolina</b>	9300 George Palmer Highway
<b>Minnesota</b>	3737 Lake Cook Road	<b>Tennessee (East)</b>	Lanham, Maryland 20801
<b>North Dakota</b>	Deerfield, Illinois 60015	<b>Virginia</b>	(301) 577-2600
<b>South Dakota</b>	(312) 272-5500	<b>Arizona</b>	Volkswagen Pacific, Inc.
<b>Wisconsin</b>		<b>California (South)</b>	11300 Playa Street
<b>Kentucky</b>	Midvo, Incorporated	<b>Nevada (South)</b>	Culver City, California 90230
<b>Ohio</b>	5000 Post Road	<b>Hawaii</b>	(213) 391-6274 (Santa Monica line)
	Dublin, Ohio 43107		(213) 870-3381 (Los Angeles line)
	(614) 889-2911	<b>Alaska</b>	Riviera Motors, Inc.
<b>Indiana</b>	Import Motors Ltd., Inc.	<b>Idaho</b>	10350 S.W. 5th Street
<b>Michigan</b>	P.O. Box 2008 (2660 28th St., S.E.)	<b>Montana</b>	Beaverton, Oregon 97005
	Grand Rapids, Michigan 49501	<b>Oregon</b>	(503) 646-3111
	(616) 949-7788	<b>Washington</b>	
<b>Florida</b>	Volkswagen Southeastern	<b>Arkansas</b>	Volkswagen Mid-America, Inc.
<b>Georgia</b>	Distributor, Inc.	<b>Missouri</b>	8825 Page Boulevard
<b>South Carolina</b>	155 East 21st Street	<b>Kansas</b>	St. Louis, Missouri 63114
	Jacksonville, Florida 32203	<b>Nebraska</b>	(314) 429-2141
	(904) 355-1684	<b>Colorado</b>	Volkswagen South Central
<b>Delaware</b>	Volkswagen Atlantic, Inc.	<b>New Mexico</b>	Distributor, Inc.
<b>Pennsylvania</b>	1001 South Trooper Road	<b>Oklahoma</b>	P.O. Box 2207
	Valley Forge, Pennsylvania 19481	<b>Texas</b>	San Antonio, Texas 78206
	(215) 666-7500	<b>Wyoming</b>	(512) 341-8881
<b>Alabama</b>	International Auto Sales & Service, Inc.	<b>California (North)</b>	Reynold C. Johnson Company
<b>Louisiana</b>	4200 Michoud Boulevard	<b>Nevada (North)</b>	7100 Johnson Industrial Drive
<b>Mississippi</b>	New Orleans, Louisiana 70129	<b>Utah</b>	Pleasanton, California 94566
<b>Tennessee (West)</b>	(504) 254-1500		(415) 828-6700

## Customer Identification Card

This is another feature of Volkswagen Service that adds to your convenience. Just present this booklet whenever you stop for service at your Authorized Volkswagen Dealer. Your Identification Card will quickly furnish the Service Adviser with your name and address and all pertinent vehicle data.

WT 5370-72

WORLD-WIDE VOLKSWAGON P	ZONE	AISLE	BIN	SHELF	COMP.	PART NUMBER	COLOR	DESCRIPTION
	K	F	23	1	1	LIT 563 -90 3- 23		QWNMN 372
	QUANTITY		ORDER NO.		DLR. NO.		TYPE	
	4		77282		054		1	