

Volkswagen Owner's Manual: Operation and Maintenance

Type 1

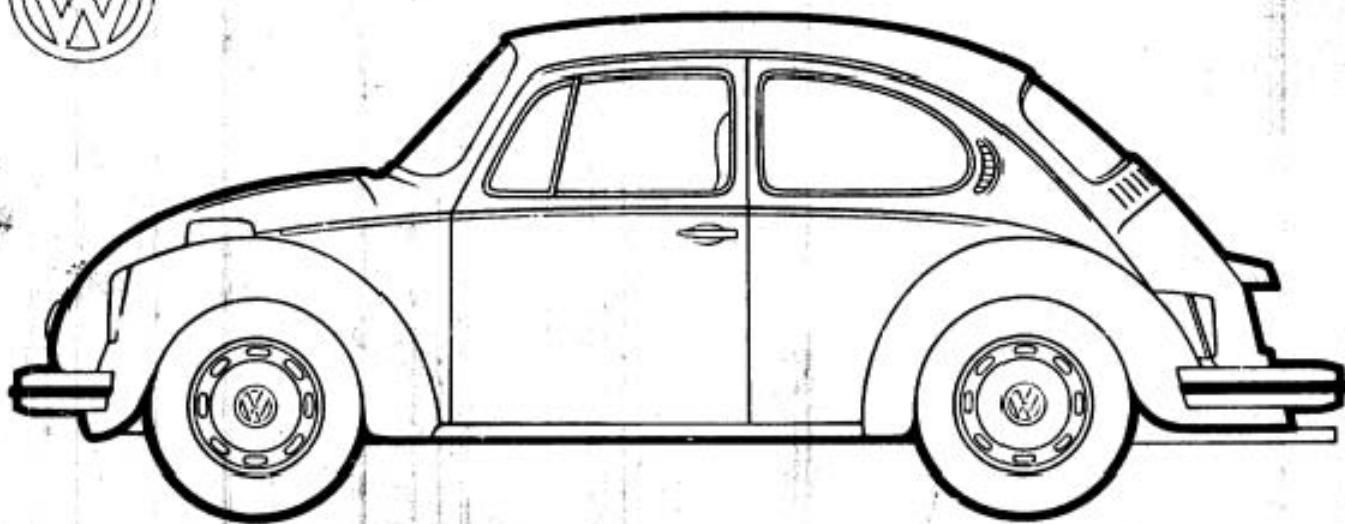

Owner:

| | | |
|-----------|------------|---------|
| Last name | First name | Initial |
|-----------|------------|---------|

Street

| | | |
|------|-------|----------|
| Town | State | Zip code |
|------|-------|----------|

| | |
|-----------|----------|
| Area code | Tel. No. |
|-----------|----------|

Volkswagen Owner's Manual: Operation and Maintenance

1973 Models



Volkswagen
Sedan 111



Volkswagen
Sedan 113



Volkswagen
Convertible

Volkswagenwerk Aktiengesellschaft

© 1973 Volkswagenwerk Aktiengesellschaft
All rights reserved.

May not be reproduced or translated in whole or in part without the written consent of Volkswagenwerk AG.
Specification subject to alteration without notice.

202.661.079.23

Printed in Germany 1.73

II

The **VOLKSWAGEN OWNER'S MANUAL** consists of two major parts: operation description and Diagnosis & Maintenance record.

The first part acquaints you with your Volkswagen Warranty and the operation of your car. It also gives you information on fuel, oil, lubrication, plus technical data.

The second part deals with the maintenance of your Volkswagen. It explains what the **VOLKSWAGEN DIAGNOSIS and MAINTENANCE** is all about, and how to keep your Volkswagen in top driving condition. Check the mileage chart at the end of this manual. It will tell you when to bring your car to your Authorized Volkswagen Dealer for periodic oil change, diagnosis and maintenance services.



The first maintenance service at 600 miles is free of charge (you only pay for engine and transmission oil).

You are further entitled to free diagnosis services at 6,000, 12,000, 18,000 and 24,000 miles.

Always have your Volkswagen Owner's Manual with you when you take your car to an Authorized Volkswagen Dealer for service . . . it provides your Service Adviser with the information he needs and enables him to make the necessary entries for you.

Please read this manual before you drive your new Volkswagen. Acquaint yourself with its features, and know how to operate it more safely . . . because the more you know about it, the more you will enjoy driving your Volkswagen.

Pictures and text in this manual are based on the 1973 Volkswagen Sedan 113 with Manual Transmission. Where the controls, equipment and technical data of the Volkswagen Sedan 111, the Automatic Stick Shift and the Volkswagen Convertible differ considerably, we will point this out in the text.

Various items shown or described in the manual may be options on certain models. Check with your Authorized VW Dealer on available options or accessories.

It has always been Volkswagen's policy to continuously make technical improvements; therefore, the right is reserved to make changes at any time during the model year without notice.

CONTENTS

| | page | | page | | page |
|--|------|---|------|--|------|
| Address change cards | D 12 | Glove compartment | 20 | Technical data | 60 |
| Air cleaner | 52 | Headlight switch | 11 | Tires | 32 |
| Air Conditioner | 28 | Heater | 22 | Towing and trailer hauling | 30 |
| Alternator warning light | 12 | Heater lever spot light | 22 | Transmission oil grades | 55 |
| Ashtrays | 15 | Ignition/steering lock | 10 | Troubleshooting | 56 |
| Assist straps and coat hooks | 15 | Instrument illumination | 11 | Turn signal/headlight dimmer switch lever | 13 |
| Automatic Stick Shift | 18 | Instrument panel | 8 | V-belt: adjusting or replacing | 48 |
| Automatic Transmission Fluid | 51 | Interior light | 15 | Vehicle Identification | 3 |
| Auxiliary Heater | 27 | Jack | 34 | Ventilation | 24 |
| Battery | 40 | Keys | 4 | Warranty | VII |
| Brake fluid reservoir | 39 | Lane changer | 13 | Windows | 5 |
| Brake warning light | 11 | Lubrication | 53 | Windshield washer fluid container | 39 |
| Bulb chart | 45 | Luggage compartments | 21 | Windshield wiper/washer lever | 13 |
| Bulb replacing | 46 | Maintenance record | D 7 | Winter operation | 31 |
| Changing a wheel | 35 | Manual Transmission | 16 | | |
| Changing engine oil | 50 | Manual Transmission oil | 51 | | |
| Chassis number | 3 | Oil pressure warning light | 12 | | |
| Checking engine oil level | 49 | Rear seat: removing and installing | 45 | | |
| Cleaning your VW | 43 | Rear view mirrors | 14 | | |
| Convertible top | 26 | Rear window defogger | 14 | | |
| Dear VW Owner | 1 | Safety belts | 6 | | |
| Defroster | 23 | Seats | 5 | | |
| Diagnosis and Maintenance | D 1 | Sliding roof | 25 | | |
| Distributor addresses | 59 | Spare wheel | 33 | | |
| Doors | 4 | Spark plugs: cleaning and replacing | 49 | | |
| Emergency flasher | 10 | Speedometer with fuel gauge and warning lights | 12 | | |
| Engine oil grades | 54 | Starting hints | 20 | | |
| Fuel gauge | 12 | Sun visors | 15 | | |
| Fuel supply | 40 | | | | |
| Fuses | 41 | | | | |

Volkswagen offers a quality product. Maintain this quality by having your Volkswagen serviced regularly. A service schedule that we recommend is explained in the section Volkswagen Diagnosis and Maintenance.

Should you have occasion to make use of your Volkswagen Warranty, it is always helpful to have the related service receipts handy.

WARRANTY VOUCHER

for the new VW automobile

Type: _____

Chassis No. _____

Engine No. _____

In accordance with the **terms of warranty** printed overleaf.

The warranty commences at the date the VW automobile is delivered to the original purchaser.

viz. on _____
(To be filled in by selling VW Dealer)

and covers a period of 24 months or the period before the vehicle has been driven 24,000 miles, whichever event shall first occur. Should any warranty claim arise, you are requested to present this voucher to your VW Dealer.



Volkswagen of America, Inc.



Except for the following warranty and the Emission Control System warranty by Volkswagen of America, Inc, no express warranties as to Volkswagen vehicles sold in the United States are made either by Volkswagen of America, Inc. ("VWoA"), or by the manufacturer, the distributor or the selling dealer.

Warranty for New Volkswagen Vehicles

This warranty is issued by Volkswagen of America, Inc. ("VWoA"), the authorized United States importer of Volkswagen vehicles.

Free repair or replacement in the United States and Canada of defective parts for 24 months or 24,000 miles

1. VWoA warrants that every Volkswagen vehicle imported by VWoA and sold as a new vehicle to a retail customer by an authorized United States Volkswagen dealer will be free from defects in material and workmanship under normal use and service for 24 months after the date of delivery of the vehicle to the original retail customer or until the vehicle has been driven 24,000 miles, whichever comes first. This warranty is limited, however, to the following: If any part of the vehicle becomes defective under normal use and service and the vehicle is brought during this period to the workshop of any authorized Volkswagen dealer in the continental United States, Hawaii or Canada, the dealer will, without charge, either repair the defective part or replace it with a new or factory reconditioned part.

Maintenance required to keep warranty in effect

2. In order to keep this warranty in effect, the owner must have the vehicle maintained and serviced as prescribed in the Volkswagen Maintenance Schedule.

Items not covered by warranty

3. VWoA's warranty does not cover:

(i) Defects, damage or deterioration due to normal use, wear and tear or exposure; (ii) normal maintenance services, such as fuel system cleaning and wheel, brake or clutch adjustments; (iii) the replacement of service items, as for instance, spark plugs, ignition points, wiper blades or brake linings; (iv) deterioration of upholstery, soft trim and appearance items; (v) damage or defects due to misuse, alteration, negligence or accident; (vi) damage or defects due to the repair of the vehicle by someone other than an authorized Volkswagen dealer or the installation of parts other than genuine Volkswagen parts; (vii) damage or defects due to the use of the vehicle in competitive events, including rallies and races; and (viii) loss of time, inconvenience, loss of use of the vehicle or other consequential damage.

Warranty outside the United States and Canada

4. If the vehicle is brought to an authorized Volkswagen workshop outside the continental United States, Hawaii or Canada, VWoA's warranty will not be applicable and defective parts will be repaired or replaced free of charge with new or factory reconditioned parts only within the terms and limitations of the warranty for new Volkswagen vehicles in effect in the country where such authorized Volkswagen workshop is located.

No other warranties made

5. This warranty and the Emission Control System warranty for Volkswagen vehicles are in lieu of all other express warranties of VWoA, the manufacturer, the distributor and the selling dealer. Neither VWoA nor the manufacturer assumes, or authorizes any person to assume, on its behalf, any other obligation or liability.

Let us explain the warranty ...

Volkswagen of America, Inc. is proud of the quality of the automobiles it imports. It warrants new vehicles for a period of 2 years or 24,000 miles from the date of purchase, whichever comes first. In general, the complete vehicle including battery and tires is covered under the provisions of the Volkswagen New Vehicle Warranty. It will be honored by any Authorized Volkswagen Dealer in the continental United States, Hawaii and Canada.

This warranty is transferable if the ownership of the vehicle changes within the above period.

In order to keep the warranty in force, you, as the owner of the vehicle, have certain responsibilities. It is important that the vehicle be maintained properly. To facilitate record keeping, this booklet provides space for listing diagnosis, maintenance, and oil change services as they are performed.

Diagnosis and maintenance services should be performed by Authorized Volkswagen dealers. They have Volkswagen trained mechanics and special tools to provide fast, efficient service in accordance with Volkswagen quality standards.

The terms of your warranty require you to keep a maintenance record of your vehicle. Provided that maintenance or oil change services were performed in accordance with Volkswagen specifications, dated bills of other than Authorized Volkswagen dealers will be accepted as proof that these services were performed when required.

Not all repairs, adjustments and replacements, however, are the result of defects in material or workmanship. There are other circumstances beyond the control of the manufacturer that might make a workshop visit necessary. These depend mainly on where you drive and how you drive. They would include weather and atmospheric conditions, varying road surfaces, individual driving habits and vehicle usage.

For example, you are required to pay for the following:

Lubrication services

Diagnosis and Maintenance services – except those free of charge as specified in the Owner's Manual.

Wheel alignment and wheel balancing. The frequency of these services depends on driving conditions such as rapid starts and stops, tire skidding, hitting pot holes and curbs, etc.

Mechanical adjustments – including brakes, clutch, door locks – are required as a matter of normal operation of a motor vehicle. This protects you against early or expensive replacements.

Brake and clutch linings are directly affected by driving habits and use. The replacement of linings and the reconditioning of brake drums or brake discs should be performed whenever necessary.

Spark plugs and ignition points are subject to wear. Periodic replacements ensure you of maximum engine performance and gasoline economy.

Wiper blades will have a varied life expectancy, depending on climatic conditions and extent of use. You are the best judge of when they should be replaced.

Light bulbs and fuses are service items.

Paint, chrome, convertible top, trim and other appearance items are affected by normal wear and exposure. Proper care of these items can add to their appearance and durability. (Imperfections are normally apparent during New Vehicle Delivery Inspection. For your protection, please report any imperfection to your dealer immediately.)

Tires and battery are subject to wear. If there is a manufacturer's defect, you pay only for the amount of use you obtained. An adjustment for tires is based on the remaining tread depth. Battery adjustment is according to time used, based on 24 months of service. This is known as the pro-rata method of adjustment.



Volkswagen parts, accessories and exchange units are identified by these trademarks.

All meet the same exacting quality control standards as the original equipment on the car, and comply with all applicable Government safety regulations.

They are guaranteed to be free from defects in material or workmanship for a period of 6 months or 6,000 miles, whichever comes first.

All Volkswagen parts and accessories are available at your Authorized Volkswagen Dealer.

Also, ask him about rebuilt parts under the Volkswagen Exchange Service . . . they cost less than new parts but carry the same warranty.

Dear VW Owner:

A lot has gone into the manufacture of your Volkswagen. Including advanced engineering techniques, rigid quality control and demanding inspections. The engineering and safety features that have gone into your VW will be enhanced by . . . you,

the safe driver

- who knows his vehicle and all the controls.
- who maintains his vehicle properly.
- who uses his driving skills wisely.

Because safe driving is important to you, we urge you to read this manual carefully, to maintain your VW properly and to follow the check list shown on this page whenever you use your VW.

Before getting behind the wheel:

- 1 - Make sure that the tires are inflated correctly.
- 2 - Watch the tread depth indicator on the tires. Look for bruises and wear.
- 3 - See that all windows are clean and unobstructed.
- 4 - Check that headlight and tail light lenses are clean.
- 5 - Check that all lights are functioning properly.
- 6 - Check turn signal lamps and indicator light (ignition on).

In the driver's seat:

- 1 - Position seat properly for easy reach of controls.
- 2 - Adjust inside and outside mirrors for unobstructed rear view.
- 3 - Fasten safety belts.
- 4 - Check brake warning light when starting the engine.
- 5 - Check brake operation.
- 6 - Make sure that all doors are closed securely and locked.

And when you are on the highway:

- 1 - Always drive defensively. Expect the unexpected.
- 2 - Use signals to indicate turns and lane changes.
- 3 - Turn on headlights at dusk.
- 4 - Follow at a safe distance. A good rule of thumb is to allow a minimum of one car length for each 10 mph of speed.
- 5 - Reduce speed during night hours and inclement weather.
- 6 - Observe speed limits and obey highway signs.
- 7 - When tired, get off the highway, stop and take a rest.
- 8 - When stopped or parked, always set the parking brake.
- 9 - When stalled or stopped for repairs, move the car well off the road. Set the emergency flasher and use road flares or other warning devices to warn other motorists.

TYPE PASSENGER CAR
MANUFACTURED BY VOLKSWAGENWERK AG (month/year)
THIS VEHICLE CONFORMS TO ALL APPLICABLE FEDERAL MOTOR
VEHICLE SAFETY STANDARDS IN EFFECT ON THE DATE OF MANU-
FACTURE SHOWN ABOVE. (chassis number)
GVWR LB. 0000
GAWR LB. FRONT 0000/REAR 0000

This sticker is your assurance that your 1973 Volkswagen complies with all U.S. Federal Motor Vehicle Safety Standards which were in effect at the time the vehicle was manufactured. You can find this sticker on the left doorjamb.

The sticker also shows the month and year of production and the chassis number of your car (perforation) as well as the **Gross Vehicle Weight Rating** and the **Gross Axle Weight Rating**.

Vehicle Identification

The identification plate

is the "birth certificate" of your Volkswagen. It is located under the front hood next to the hood lock.

On the Volkswagen Sedan 111, the plate can be found in the spare wheel well.

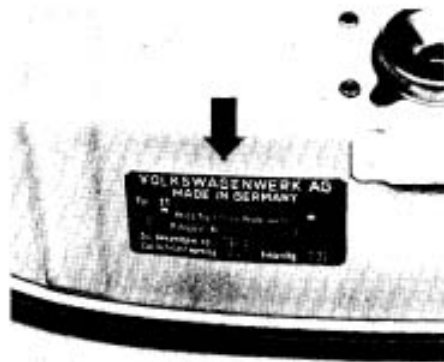

The plate shows such information as manufacturer's name, place of origin, model, weights and "Fahrgest.-Nr.", which is the chassis number of your car.

The chassis number

is also located on the instrument panel on the driver's side so that it is visible from the outside through the windshield. This is for your protection . . . to aid in the apprehension of car thieves and the recovery of stolen vehicles.



The chassis number is also stamped on the frame tunnel under the rear seat.

The engine number

is stamped on the generator support flange.

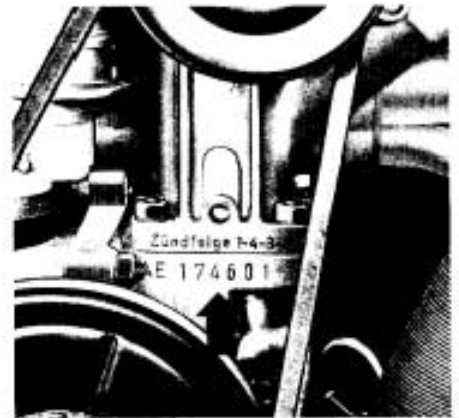

Keys

Your Volkswagen comes with two sets of keys:

The key with the elongated head is for the doors and the ignition/steering lock.



The key with the round head is for the glove compartment only. The glove compartment of the VW Sedan 111 does not have a lock.

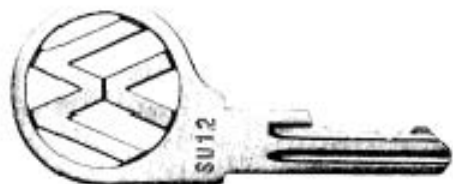

Do not invite car theft

by leaving your car unattended with the key in the ignition lock. Take the key with you and lock the doors.

A buzzer will remind you when you open the driver's door and the key is still in the ignition lock.

It is a good idea to keep a record of your key numbers in your wallet together with your license. If you should lose a key, your Authorized VW Dealer will thus be able to quickly secure a replacement key for you.

Doors

Always drive with locked doors to prevent inadvertent opening of a door from the inside, especially with smaller children in the car.

To lock and unlock doors from the outside

You can lock and unlock your car with a key, of course.

But you can also lock it without a key.

First push in the inside locking knob on the upper door panel. Then depress the plunger in the outside door handle as you close the door.

On the VW Convertible depress the locking lever in the inside door handle.

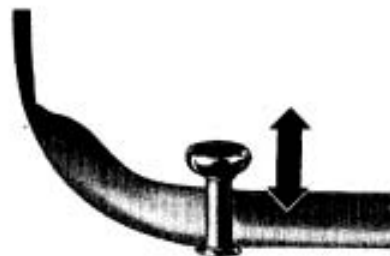

Windows

If the door, with the locking knob or locking lever depressed, closes by itself, the locking device will disengage automatically. We provided this additional safety feature so you won't be locked out if the door should slam shut while the key is still inside the car.

To lock and unlock doors from the inside –

depress or pull out the locking device. Since your Volkswagen is almost air tight it will be easier to close the door if you open a window slightly. The locking lever on the VW Convertible looks like this:

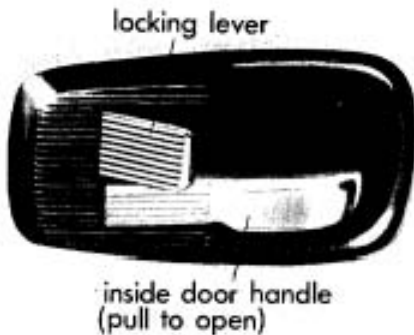

We recommend you do not put decals or other signs on the windows of your car that will interfere with the driver's vision.

You can lower and raise the windows in the front doors by means of winders. We cushioned the knobs for your safety.

To open the vent window, turn knob into driving direction, move locking lever forward and push out window.

To make closing the vent window easier, we suggest you first push on the forward part of the vent window so that it fits snugly against the weatherstripping. Then grasp the knob, and move the lever back to lock it in place.

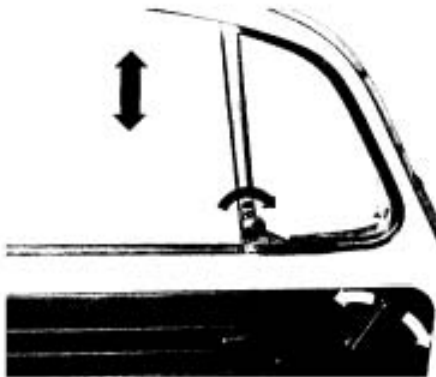

Seats

We recommend you do not adjust the driver's seat while driving. Your seat may suddenly jerk forward or backward, which could result in loss of control.

Your Volkswagen has adjustable front seats with built-in headrests.

Seat adjustment

To move the seat forward and backward pull the lever on the inboard side of the seat. Now slide the seat to the desired position. Let the lever go, and move the seat slightly back and forth to make sure it is securely engaged.

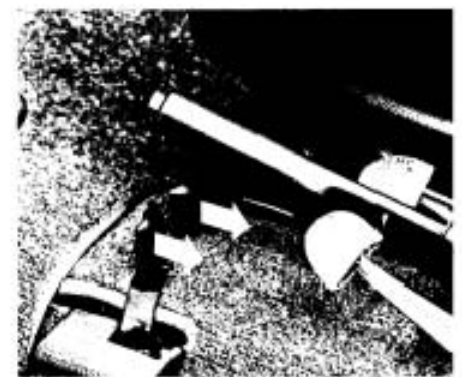

Safety belts

Backrest adjustment

To adjust the backrest, lift the lever at the outboard side of the seat cushion as you exert slight body pressure in the direction desired. Let the lever go to lock the backrest in position.

We have installed a lock on the side of the backrest.

You can disengage this lock by pulling up the lever. Tilt the backrest forward and out of the way for easy access to the rear seat and rear luggage compartment.



A safety belt is provided for each seating position in your Volkswagen. For your protection, **fasten your safety belt before driving off and wear it at all times while the car is in motion.**

Safety belts that were subjected to excessive stretch forces during an accident should be replaced.

An audio-visual warning system for the front seats will remind the driver and front passenger to put on their safety belts. The buzzer will sound and the FASTEN SEAT BELTS sign on the dashboard will light up as soon as a gear is engaged. The warning system will also be activated if the passenger in the front passenger seat is not wearing a safety belt.

Make sure the belt of the unoccupied passenger seat is fully wound up on its retractor so that the belt tongue is in its stowed position behind the assist strap on the doorpost. This reduces the possibility of its becoming a striking object in case of a sudden stop.

Do not strap in more than one person in each belt.

Safety belts for front seats

The front seats are equipped with lap/shoulder belts with an automatic locking retractor. The belt adjusts automatically to your size and movements as long as the pull on the belt is slow. **A sudden motion locks the belt.** The automatic locking mechanism in the retractor will also lock the belt when driving down a steep hill or in a curve, and when the car's speed is reduced.



A shoulder belt should not be worn by a person less than 4'7" in height, because it would not be in its most protective position, and therefore may increase the possibility of injury in a collision.

To fasten your lap/shoulder belt, grasp the belt tongue and pull the belt in a continuous slow motion across your chest and lap. Insert the belt tongue into the corresponding anchor housing on the center tunnel and push down until it is securely locked with an audible click. **Belts should not be worn twisted.**

To unfasten the belt, push in the release marked PRESS on the corresponding anchor housing. The belt tongue will spring out of the anchor housing.

To store the lap/shoulder belt, guide the belt tongue to its stowed position behind the assist strap on the door post. For the passenger's comfort, the retracting forces of the belt are relatively low and winding up of the belt may be slow. Make sure the belt is fully wound up on the retractor.

Safety belts for rear seats

The rear seats are equipped with lap belts with an automatic retractor. If you have pulled out too much of the belt, the retracting mechanism will take up the slack until the belt fits snugly across your lap and will stay locked in this position.



To fasten your lap belt, grasp the belt tongue on the outboard side of the seat, and pull it across your lap and insert the tongue in the inboard buckle. Push in until you hear a click to be sure the belt is locked securely.

To unfasten the belt, push in the release marked PRESS in the buckle.

To store the belt, guide the belt tongue to the retractor. Make sure the belt is fully wound up on the retractor. Belt tongue and buckle should always be kept on top of the seat for ready use. Do not permit them to get caught under the seat.

Belt care

Keep safety belts clean. If cleaning is necessary, wash them with a mild soap solution, without removing them from the car.

Do not allow the belts to retract until they are completely dry.

Do not bleach or dye safety belts. Do not use any other cleaning agents. They may weaken the webbing.

Check buckles and retractors for proper function. Check belt webbing and bindings for damage.

Instrument panel

VW 111

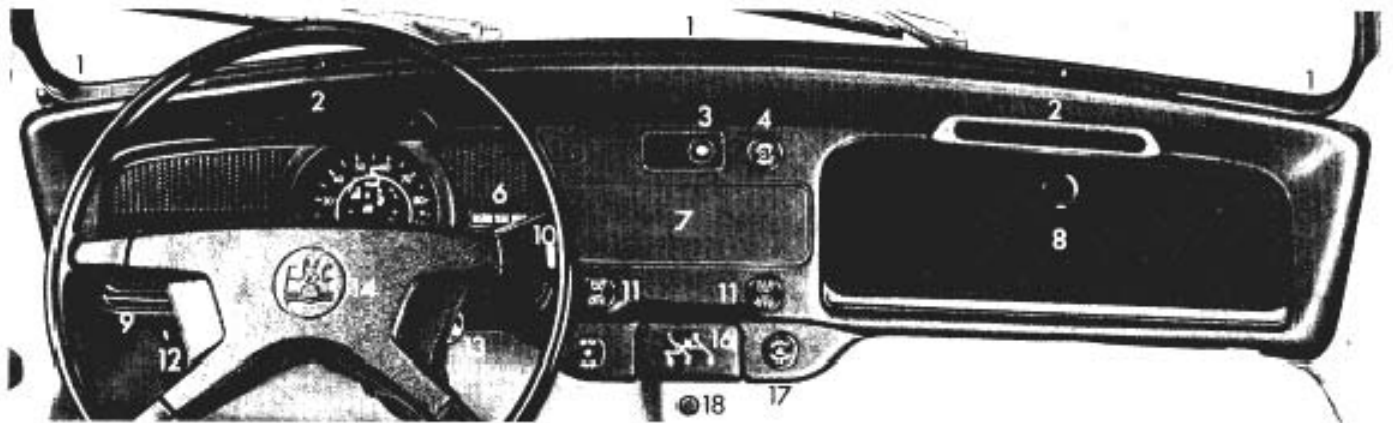

| | | | |
|--|-------|--|----|
| 1 – Vents for heating/defrosting (there are 3) | 23 | 11 – Fresh air control knobs (2) | 25 |
| 2 – Vents for heating/defrosting and fresh air ventilation (there is a pair on each side) | 23/25 | 12 – Fuse box | 41 |
| 3 – Brake warning light | 11 | 13 – Ignition/steering lock | 10 |
| 4 – Headlight switch | 11 | 14 – Horn | |
| 5 – Speedometer dial with fuel gauge and warning lights | 12 | 15 – Control knob for Auxiliary Heater (optional equipment) | 27 |
| 6 – Safety belt warning light | 6 | 16 – Ashtray | 15 |
| 7 – Plate over radio aperture | | 17 – Emergency flasher switch | 10 |
| 8 – Glove compartment | 20 | 18 – Spot light to illuminate the heater levers between the front seats | 22 |
| 9 – Turn signal and headlight dimmer switch lever | 13 | | |
| 10 – Windshield wiper/washer lever | 13 | | |

VW 113 and Convertible

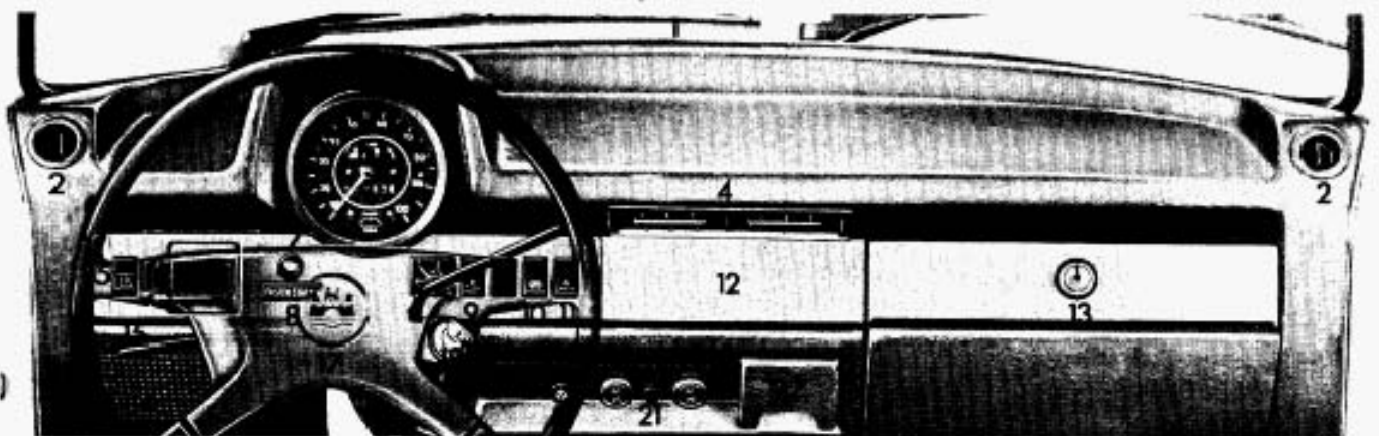

| | | | |
|---|----|---|----|
| 1 – Vent for heating/defrosting and fresh air ventilation (over the full width of the windshield) | 22 | 11 – Emergency flasher switch | 10 |
| 2 – Vents for heating/defrosting and fresh air ventilation for the front side windows (there is one on each side) | 23 | 12 – Plate over radio aperture | 10 |
| 3 – Speedometer dial with fuel gauge and warning lights | 12 | 13 – Glove compartment, lockable | 20 |
| 4 – Vents for fresh air ventilation (2) | 24 | 14 – Loudspeaker grille | 13 |
| 5 – Headlight switch | 11 | 15 – Turn signal and headlight dimmer switch lever | 13 |
| 6 – Instrument illumination | 11 | 16 – Windshield wiper/washer lever | 13 |
| 7 – Brake warning light | 11 | 17 – Horn | 10 |
| 8 – Safety belt warning light | 6 | 18 – Ignition/steering lock | 24 |
| 9 – Control switch for Auxiliary Heater (optional equipment) | 27 | 19 – Knob for fresh air fan | 24 |
| 10 – Switch for rear window defogger (VW Sedan 113 only) | 14 | 20 – Fresh air control knobs (2) | 24 |
| | | 21 – Spot light to illuminate the heater levers between the front seats | 22 |
| | | 22 – Ashtray | 15 |

Ignition/steering lock

The steering is equipped with an anti-theft ignition lock.

Fasten safety belts. Make sure the gear-shift lever is in Neutral before turning the ignition key.

- 1 — Ignition off/steering locked.
Insert the key. If it is difficult to turn the key, gently move the steering wheel until the key turns freely.
- 2 — Ignition on/steering free (for towing).
- 3 — Starter engages.
The key returns to position 2 as soon as it is released. Never operate the starter longer than a few seconds. If the engine should fail to start, turn the key back to position 1 and repeat the starting procedure. More on starting on page 20.

To remove the key and to lock the steering, turn the key back to position 1 and pull it out. Turn the steering wheel until it locks.

The steering column will lock when you remove the key. Therefore DO NOT REMOVE the key while you are driving or as the car is rolling to a stop.

If you leave the key in the ignition/steering lock, the buzzer will sound when the driver's door is opened. This is your reminder to remove the key.

Emergency flasher switch

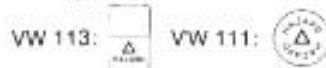

If your car is disabled or parked under emergency conditions, depress the lower half of the rocker switch (VW 111, pull out the knob) to make all four turn signals flash simultaneously. The warning light in the switch or knob flashes, too.

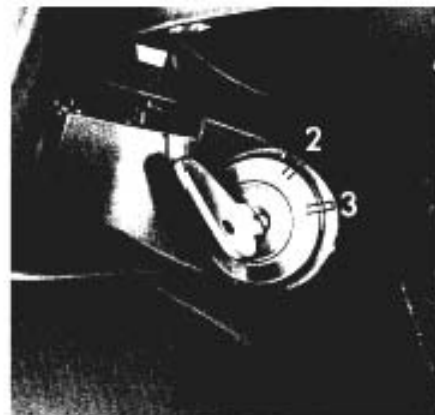

When the headlight switch is operated, the emergency flasher switch or knob glows with reduced brightness for easy recognition in the dark. When the emergency flasher is not in operation, the brightness of the light can be regulated together with the instrument panel lights (see instrument illumination). The light has full brightness when the emergency flasher system is in operation.

Move the car well off the road when stalled or stopped for repairs.

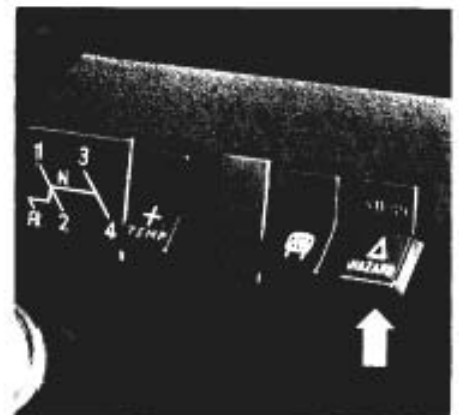

Brake warning light



Your Volkswagen is equipped with a dual circuit brake system. Both circuits, one for the front brakes and one for the rear brakes, can function independently.

If the brake warning light lights up when you apply the brakes while driving, one of the two brake circuits may have failed.

The other brake circuit will still operate, but a longer distance and greater pedal pressure are required to bring the car to a halt.

Pull off the road and stop.

Try out the effectiveness of the brakes



by carefully starting and stopping on the road shoulder.

If you judge that the brakes operate safely enough to take you to the nearest dealer, proceed cautiously and at low speed. If you do not feel it is safe to continue, have your car towed to the nearest dealer for repair.

Proper functioning of brake warning light

The brake warning light will light up when the ignition is turned on. It will go out after the engine has been started. This is your assurance that the brake warning light functions properly.

If the brake warning light does not light up when turning on the ignition, or if it does not go out after starting, there may be a defect in the electrical system. If this is the case, contact your Authorized VW Dealer.

In some **VW 111 models**, checking of the brake warning light is accomplished as follows: Depress the brake warning light after turning the ignition on. If the knob does not light up, contact your nearest VW Dealer.

Headlight switch – VW 113



Depress the rocker switch to the first stop to turn on the parking and side

marker, license plate, tail and instrument lights, emergency flasher light, spot light for the heater levers and the light in the TEMP-switch for the optional Auxiliary Heater.

Depress the switch to the second stop to turn on the headlights (ignition on).

Instrument illumination – VW 113

Turn the thumb wheel next to the rocker switch to adjust the brightness of the instrument lights and the heater lever spot light.

Headlight switch – VW 111



Pull the knob to the first stop to turn on the parking and side marker, license plate, tail and instrument lights, emergency flasher light, spot light for the heater levers and the light in the TEMP-switch for the optional Auxiliary Heater. Pull the knob to the second stop to turn on the headlights (ignition on).

Instrument illumination – VW 111

Adjust the brightness of the instrument lights and the heater lever spot light by turning the headlight switch knob.





Note

To preserve the battery, the headlights will go out automatically when the ignition is turned off or when the engine is started.

Speedometer dial

The speedometer indicates the speed; the odometer records the miles driven. The last digit in red indicates 1/10 of a mile.

The following warning lights are in the speedometer dial:

- a - red  alternator
- b - green  turn signals
- c - red  oil pressure
- d - blue  high beam

Fuel gauge

It is located in the speedometer dial, and only indicates the fuel level when the ignition is turned on.

When the needle is on "R", there is a reserve of about 1 gallon of fuel left in your tank . . . time to refuel at the next gas station.

The red warning lights for alternator and oil pressure in the speedometer dial will light up when the ignition is turned on. They should go out after you have started the engine.

a - Alternator warning light



Stop at once . . .

if the alternator warning light comes on while you are driving.

Turn the engine off!

Check first whether the V-belt is slipping or broken. The V-belt not only drives the alternator but also the fan that cools the engine.

Tighten or replace the belt.

c - Oil pressure warning light



Stop at once . . .

if the oil pressure warning light comes on while you are driving.

Turn the engine off!

Check the oil level to make sure you have enough oil. If the oil level is normal, do not drive on but contact your nearest Authorized VW Dealer.

An occasional flickering of the oil pressure warning light when the engine is idling after a long high-speed trip is no cause for concern if the light goes out upon acceleration.



a b c d

Whenever stalled or stopped for repair, move the car well off the road. Turn on the emergency flasher and mark the car with road flares or other warning devices. Before working on any part in the engine compartment, turn the engine off and wait until the engine has cooled down sufficiently.

Turn signal/headlight dimmer switch lever and windshield wiper/washer lever

There are two levers just behind the steering wheel:

The lever on the left side is for the turn signal/headlight dimmer switch.

The lever on the right side is for the windshield wiper/washer system.

The turn signals and the windshield wipers only work with the ignition on.

Turn signals

Lever up – right turn signal
Lever down – left turn signal

The green turn signal indicator light comes on in the speedometer dial when you operate the lever.

The turn signals are cancelled automatically when you have completed a turn (like driving around a corner), and the steering wheel returns to the straight-ahead position.

If a turn signal is defective, the control light flashes at about twice the normal frequency. Have your Authorized VW Dealer check and repair it for you.

Lane changer

To indicate your intention when changing lanes on expressways, slightly lift or depress the lever to an intermediate position. The lever will return to the OFF position when released.

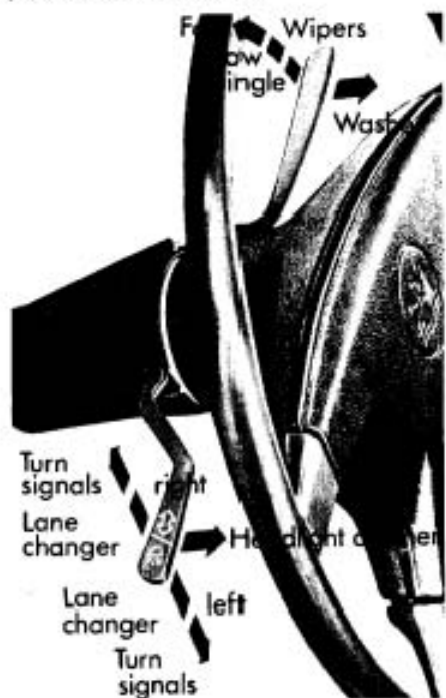

Headlight dimmer

Dim the headlights by pulling the lever toward the steering wheel. The blue indicator light in the speedometer dial will light up when the high beams are on.

Windshield wipers

The windshield wiping system operates at two speeds: low and high.

Lifting lever to first stop – low speed

Lifting lever to second stop – high speed

If you just slightly lift the lever before reaching the first stop, the wipers will wipe as long as the lever is held in this position and come to a stop when released.

To give you full battery power while starting the engine, operating windshield wipers will stop automatically at this moment.

Windshield washer

To spray washer fluid on the windshield, pull the lever toward the steering wheel. You can operate the washer from any selected wiping position.

Avoid running the wiper blades over a dry windshield . . . you may scratch the glass. Spray washer fluid on it first.

Rear window defogger (VW Sedan 113 only)



The rear window defogger — together with the flow-through ventilation — will help to keep the inside of the rear window clear of condensation and frost in the winter.

Turn the ignition on first before you switch on the rear window defogger.

Depress the rocker switch to turn on the rear window defogger. The green control lamp in the switch will light up to remind you that the defogger is switched on.

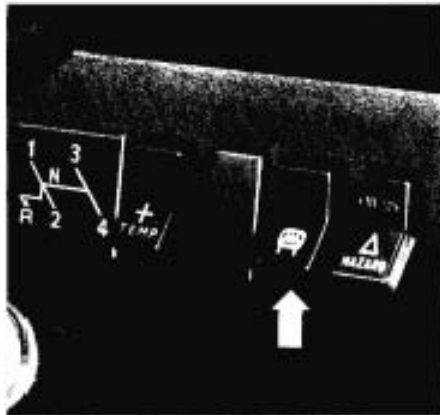

14

To give you full battery power while starting the engine, the operating rear window defogger will turn off automatically at this moment.

After the rear window has been cleared, switch off the rear window defogger to avoid an unnecessary drain on the battery.

Be careful when removing objects from the luggage compartment behind the rear seat. Sharp edges may damage the defogger in the rear window.

Rear view mirrors

Adjust the outside and inside mirrors before driving off. It is important for safe driving that you have good vision to the rear.

Outside mirror

The outside mirror is hinged and folds flat against the car when struck from either direction.

Inside day-night mirror (except VW 111)

You can move the day-night mirror from clear daylight visibility to non-glare visibility at night by adjusting the lever upward or downward at the bottom of the mirror.

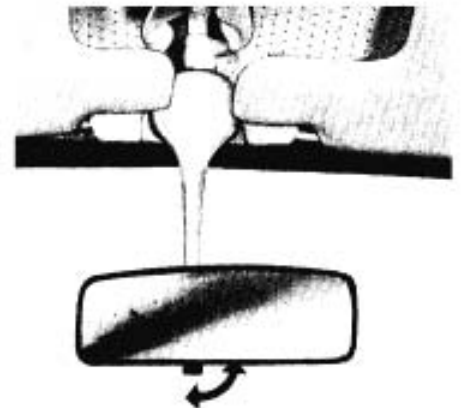

Assist straps and coat hooks

There is one assist strap and one coat hook on each side on the door post.

Hang clothes in such a way that they do not impair the driver's vision.

Interior light

The switch positions are

- Up – ON (with doors open)
- Center – OFF
- Down – ON (with doors closed)

On the VW Convertible, the light and light switch are on the mirror bracket.

The switch positions are

- Left – ON (with doors open)
- Center – OFF
- Right – ON (with doors closed)

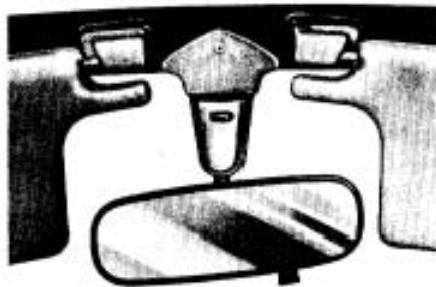
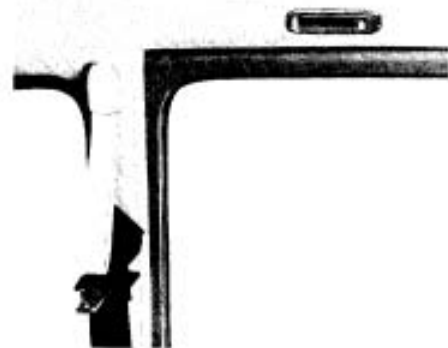

Ashtrays

Front ashtray

Pull to open the ashtray in the instrument panel. To remove the tray, depress the leaf spring which you see just beneath the top cover. Now pull out the tray.

To put it back in, fold the top cover down, insert the tray in the guide rails and push in with the heel of your hand.

Rear ashtray

To remove the ashtray in the rear passenger compartment, press down on the tray and pull out. To reinstall, just push the ashtray back in again.

Sun visors

To protect the driver from side glare, the sun visor on the driver's side can be moved toward the door window after lifting it out of its center mounting. The sun visor on the passenger's side cannot be moved toward the side.

Controls for Manual Transmission

1 – Clutch pedal

Always depress the clutch pedal fully when changing gears. Do not hold the car on a steep hill with the clutch pedal partially depressed. This may cause premature wear or damage.

2 – Brake pedal

Make it a habit to check the operation of your brakes. You will remember from page 11 that the brake warning light will alert you if one brake circuit may have failed.

Make sure that the movement of the brake pedal is not obstructed by a floor mat or any other object.

Volkswagen automobiles have excellent brakes, but they are still subject to wear ... depending on how the brakes are used. If you find that the brake pedal travel has increased, have the brakes adjusted; if necessary, between the specified maintenance intervals.

Keep in mind that the braking distance increases very rapidly as the speed increases. At 60 mph, for example, it is not twice but four times longer than at 30 mph. Tire traction is also less effective when the roads are wet and slippery. Therefore, always maintain a safe distance.

Driving through deep water may reduce tire traction. Moisture on the brakes may also affect braking efficiency. Cautiously apply the brakes for a test. If you notice a lag in the braking action, the brakes may be wet. They will dry after you have applied the brakes a few times, but do it very cautiously.

Brake linings may not have the highest possible braking efficiency when new. Therefore allow for longer braking distance during the initial 100 to 150 miles. This also applies when brake shoes are renewed.

3 – Accelerator pedal

For good fuel economy we recommend smooth and even acceleration.

Very fast, racy driving, alternating between full throttle and hard braking, raises the fuel consumption considerably. Also, tires and brake linings wear faster.

You can drive most economically between:

- 12 and 28 mph in 2nd gear
- 22 and 44 mph in 3rd gear
- 31 and 62 mph in 4th gear

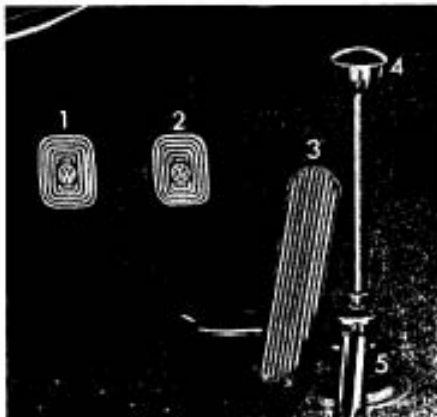

4 – Gearshift lever

The Manual Transmission is fully synchronized. The four forward gears and a reverse gear are arranged as illustrated. The shift pattern is also shown on the instrument panel below the speedometer. On the VW 111, the shift pattern is on the face of the ashtray under the dashboard.

Resting your hand on the shift lever knob while driving will cause premature wear to the transmission.

Speed ranges

You can drive your Volkswagen at full speed from the first day. You do not have a break-in schedule. There are, however, certain recommended speed ranges for the various gears:

| | |
|----------|----------------|
| 1st gear | 0–16 mph |
| 2nd | 12–34 mph |
| 3rd gear | 22–56 mph |
| 4th gear | from 31 mph up |

If you have a traffic situation where it is necessary for you to overtake rapidly, you can accelerate, for a brief period only, up to

37 mph in 2nd gear
62 mph in 3rd gear

Reverse

Only shift into Reverse when the car is not moving. To engage the reverse gear, press the lever down, move it to the left and pull back.

The back-up lights go on automatically when you engage the reverse gear (with the ignition on).

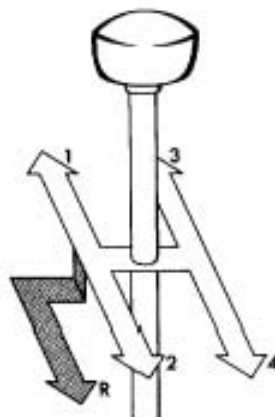

5 – Parking brake lever

To set the parking brake, press in the release button at the end of the lever as you pull up the lever. The parking brake is engaged as soon as you release the button on the raised lever.

To release the parking brake, pull the lever slightly up as you depress the release button. Then push the lever all the way down.

Be sure it is fully released. A partially engaged parking brake promotes wear of the brake lining.

Do not remove the key from the steering lock while the car is rolling to a stop. The steering column is locked as soon as you remove the key. Take out the key only after the car is parked.

Always set the parking brake when parking your car. On steep hills also turn the wheels toward the curb.

VW Automatic Stick Shift



At first glance

you will notice the lack of a clutch pedal. Driving with the Automatic Stick Shift is simpler and shifting is easier. We suggest you carefully read the following instructions to familiarize yourself with the operation of the transmission.

The Automatic Stick Shift

transmission consists of a torque converter, a power-operated clutch for shifting, and a mechanical three speed transmission. The torque converter multiplies the torque produced by the engine and allows the vehicle to be driven with very little shifting – usually two driving ranges will be used. It automatically changes the torque from the engine in an infinitely variable ratio according to driving conditions. Since the torque con-

verter is a fluid coupling, it also permits stopping the vehicle with an engaged gear while the engine is running. The clutch interrupts the flow of power from the engine to permit the gears in the transmission to be shifted. Because the power-operated clutch is actuated by the first slight movement of the gearshift lever, there is no need for a clutch pedal.

Driving ranges

With the lever mounted on the frame tunnel you can select three forward drive ranges and one reverse. The neutral position "N" is between all gears in the H-pattern.

Neutral

is the only range in which you can start the engine. In this position, the power flow to the rear wheels is interrupted. It should be used when the car is standing at idle, with the parking brake engaged.

From the Neutral position you select the desired drive range.

Driving Range 1

is for starting off and accelerating. It covers the speed range from 0–53 mph. **Always use this range first before shifting into Range 2.** Range 1 is also recommended for use in city traffic, slow moving lines of vehicles, and whenever maximum acceleration is required for passing. If the lever is in Range 2, you may downshift into Range 1 at any speed under 53 mph.

Driving Range 2

Always use Range 1 first before shifting into Range 2. Range 2 should normally be used for highway driving. It is the only range that can be used for speeds above 53 mph. You may shift into Range 1 at any speed under 53 mph.

Low Range

Shift into Low when you want to get the car moving up steep hills, especially when carrying a heavy load or when towing, and when driving down a steep hill or parking in tight spaces.

Reverse

Engage the reverse gear **only** when the car is not moving. Depress the selector lever first to overcome a safety catch before shifting into Reverse. The back-up lights go on automatically when the reverse gear is engaged (with the ignition on).

Moving off

With the parking brake set, move the selector lever to Neutral and start the engine. Shift into the range you wish to use, normally Range 1. After shifting be sure to remove your hand from the lever to allow the clutch to engage. To move off, release the brake and accelerate.

Do not release the brake before you are prepared to move, because power is transmitted to the wheels as soon as a gear is engaged.

Shifting

is easy. Simply release the accelerator pedal and move the gearshift lever from the range you are into the range you want, remove your hand from the gearshift lever, and again step on the accelerator.

For easier selection of the driving ranges 1 and 2, which are used most, the gear-

shift lever always stays on the right side when in Neutral, as shown in the illustration.

Stopping

Release the accelerator and apply the foot brake. If you are going to start off again in another range, you may shift into the new range while the vehicle is standing still, but if you remain in a driving range apply the foot or parking brake to prevent the vehicle from creeping.

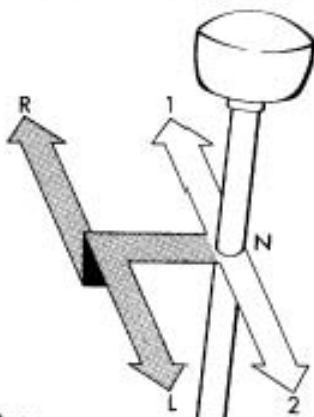

Parking

Do not remove the key from the ignition/steering lock until you have parked the car, because removal of the key locks the steering.

When parking your car, apply the parking brake, and turn the wheels toward the curb.

If you like quiet, smooth driving,

which saves fuel, we recommend that you shift to Range 2 at about 20 to 25 mph.

If you want maximum acceleration

you can stay in Range 1 right up to 53 mph and then shift into Range 2. Naturally, this will use more fuel.

Keep in mind . . .

- 1 - When starting off, shift into a driving range before releasing the parking brake.
- 2 - After shifting, remove your hand from the selector lever.
- 3 - When idling for an extended period of time, shift into Neutral and apply the parking brake. When stopped in traffic, apply either the parking or foot brake to prevent creeping.
- 4 - When parking, apply the parking brake. On hills, also turn the wheels toward the curb.

Starting hints

Never start or let the engine run in an enclosed unventilated area. Exhaust fumes from the engine contain carbon monoxide which is colorless and odorless. Carbon monoxide, however, is a very harmful gas, and can be fatal if inhaled.

Before turning the ignition key, make sure the gearshift lever is in Neutral. The Automatic Stick Shift can be started in Neutral only.

As soon as the engine starts, release the ignition key.

If the engine does not start the first time or stalls, turn the ignition key all the way to the left and restart.

Operate the starter for a few seconds only.

Summer starting

Operate the starter while slowly depressing the accelerator pedal.

Winter starting

First depress the accelerator pedal fully and release slowly to activate the automatic choke. Then start the engine.

On the Manual Transmission, also depress the clutch pedal when starting so that the starter only has to crank the engine.

Do not try to warm up the engine by letting it idle with the car stationary . . . drive off immediately and maintain moderate speed until the engine is warm.

Starting the engine at operating temperature

Before operating the starter, depress the accelerator pedal fully . . . **do not release it.** Now start.

Glove compartment

To open – Turn knob to the left
To close – Press door; lock engages
To lock or unlock – Turn key to right (except VW 111) or left

Inside the glove compartment is the **release lever for the front hood**. A locked glove compartment prevents access to the luggage compartment and the spare wheel.

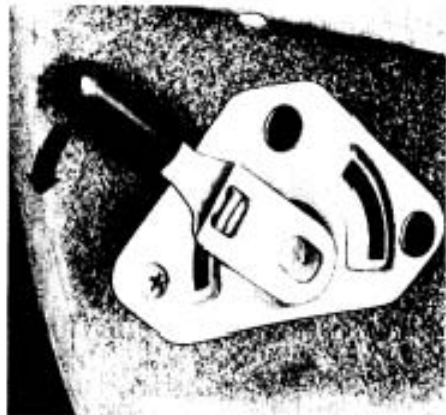

Luggage compartments

Your VW has two luggage compartments, one under the front hood, and the other behind the rear seat.

Front luggage compartment

To **unlock** the front hood, pull the release lever inside the glove compartment. See previous page.

Now open the front hood by depressing the release button in the hood handle.

To **lock** the front hood, lower the hood and press the handle down firmly. Do not press on one side of the hood. Make sure the hood is securely locked.



Since improper weight distribution can affect the car handling, take advantage of the two luggage compartments. Load the front luggage compartment first, using the heaviest pieces of luggage, if possible.

Rear luggage compartment

Additional luggage can be stored in the space behind the rear seat. You can expand this luggage area by folding the backrest down and fastening it in this position.

To **release** the backrest, pull the strap on the left, as seen in driving direction. When you fold the backrest back, it locks automatically in its place.

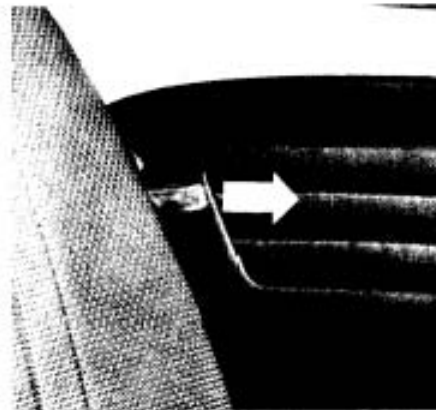

To **hold** the backrest in the folded-down position, hook the retaining strap (on the back of the backrest) under the seat rail.

To **adjust** the length of the strap, unhook the strap and move the slide.

A - to lengthen the strap

B - to shorten the strap

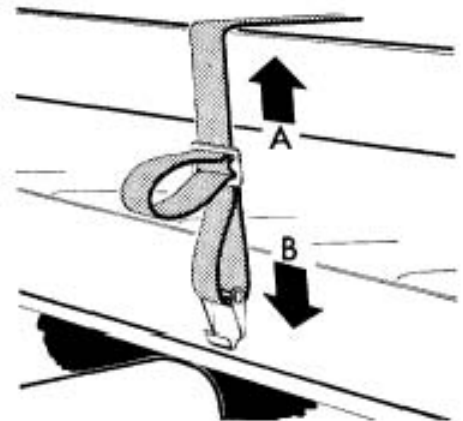



Articles stored in the luggage area behind the rear seat can be concealed from the outside view by a **cover**. This cover is attached with hinges to the backrest.

To make use of the cover, release the backrest and fold it forward. Lift the cover up. Then move backrest and cover back. The cover will rest on the edge below the rear window. Press the backrest back to lock it in place.

We recommend you do not place articles on the cover. Such items may become dangerous projectiles when dislodged during a sudden stop. They may also reduce the driver's vision to the rear.

22

Heater/Defroster

A fresh air heater/defroster is standard equipment on your Volkswagen. The control levers are located on the tunnel between the front seats. The heater lever spot light will illuminate the levers when the parking or headlights are turned on. The brightness of the spot light and instrument illumination can be adjusted by turning the thumb wheel (VW 111: light switch knob). See page 11.

1 a - Heater temperature lever (TEMP)

The lever toward the passenger's seat controls the temperature level.

Lever up - heat on fully
Lever down - heat off

By setting it at any intermediate position, you can select the degree of heat that is most comfortable for you.

VW 113

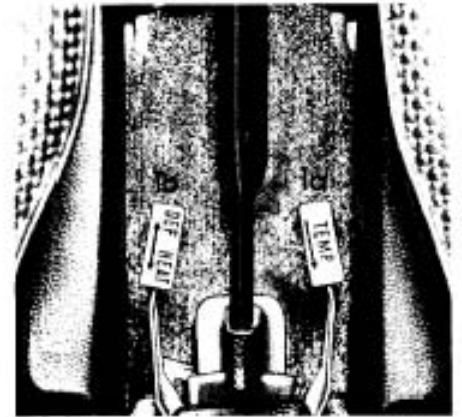
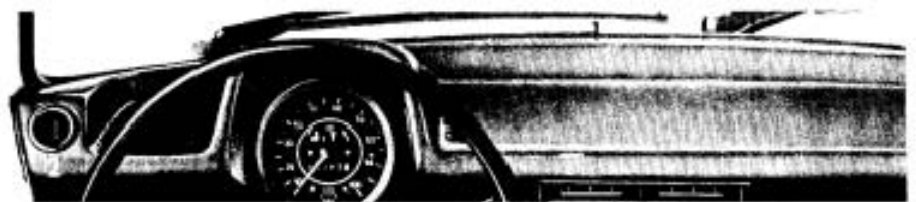

After a reasonable warm-up time, which also depends on the speed of the car, warm air will enter the car's interior through the windshield vent - 1 -, the side window vents - 2 -, and outlets in the front and rear footwells.

In the **VW 111**, warm air will enter the car's interior through the three windshield vents - 1 -, the heater/defroster vents - 2a - below the windshield and outlets in the front and rear footwells.

Footwell outlets

There are four footwell outlets, two in the front and two in the rear. The front outlets are located just beneath the doors, the rear outlets are under the rear seat. Front and rear footwells are opened and closed with the heat distribution lever - 1b -.

1b - Heat distribution lever for front and rear footwells (DEF-HEAT)

With the lever on the tunnel next to the driver's seat you can control the distribution of heat to the front and rear footwells.

Lever down - front and rear footwells closed

Lever up - front and rear footwells fully open

You can select any intermediate position to regulate the distribution of heat to the front and rear footwells.

2 - Defroster vents for front side windows

(except VW 111)

Volume and direction of the air coming from the outlets on the dashboard can be controlled separately by adjusting the flaps in the outlets. They can be opened or closed by pressing against one side of the flaps. When the flaps are closed, the entire volume of warm air flows through the vent at the windshield (- 1 -).

Hints for defogging and defrosting

Defogging and defrosting your windshield will be more effective if you direct the total air flow toward the windshield.

Here is what to do:

1. Heater temperature lever - 1a - all the way up (TEMP) - heat is on.
2. Heat distribution lever - 1b - all the way down (DEF) - no heat to the front and rear footwells.
3. For side window defogging/defrosting turn the flaps in vents - 2 - to the side - air toward the front side windows.

To increase the fresh air flow, turn the left fresh air knob - 20 - to the left (see page 36) and turn on the fresh air fan - 19 -.

Now all air is directed toward the windshield and front side windows.

VW 111



In the **VW 111**, follow the above steps 1. and 2. In addition, set the levers in the vents - 2a - below the windshield straight up. Turn the fresh air knobs - 11 - (see page 25) to the left to increase the air flow - now all air is directed toward the windshield.

Ventilation

Flow-through ventilation provides a continuous draft-free exchange of air while driving. Air enters the car through the grille on the front hood and inside vents. A water separator prevents rain from entering.

The air in the passenger compartment is drawn out through inside openings near the rear window and escapes to the outside through louvers.

A two-speed electric fan (except VW 113) behind the instrument panel increases the flow of air when driving at low speeds and also supplies fresh air when the car is standing still (ignition on).

VW 113

20 – Fresh air knobs

You can regulate the volume and distribution of fresh air with the two knobs.

Left knob – turn to left:

Air flow to windshield vent – 1 – and side window vents – 2 – increases.

Right knob – turn to left:

Air flow toward passenger compartment increases (vents – 4 –). The vanes in the vents can be adjusted upward, downward or sideways.

To **decrease** the air flow, turn the knobs to the right.

To **stop** the air flow completely, turn the knob to the right beyond the pressure point.

19 – Fresh air fan

You can increase the regular air flow by turning on the two-speed fan.

The switch positions are:

0 – off

I – low speed

II – high speed

The fan operation is most effective if you have opened the fresh air vents by turning the fresh air knobs all the way to the left.

To give you full battery power while starting the engine, the operating fresh air fan will stop automatically at this moment.

VW 113

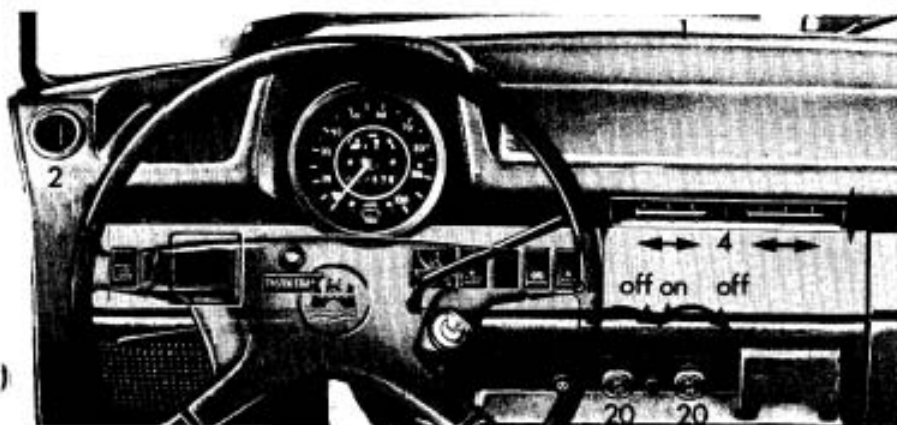

VW 111

11 – Fresh air control knobs

You can regulate the volume of fresh air for each side separately by turning the knobs.

Turn left – air flow increases

Turn right – air flow decreases

To stop the air flow completely, turn the knobs to the right beyond the pressure point.

2a and 2b – Fresh air vents

Fresh air comes out through a pair of vents on each side.

Each upper vent has a lever. When the lever is in the straight-up position the air is directed toward the windshield. In the down position (move lever to the right), the air is directed into the passenger compartment. Air will flow in both directions when you select an intermediate position.

Sliding roof

(optional on the VW 113)

We call the VW with a sliding roof the VW Sunroof.

To open the sliding roof, pull the handle out and turn it counterclockwise; to close the sliding roof, turn the handle clockwise. The sliding roof is locked in any open position.

For safety reasons, fold the handle back into its recess as shown in the illustration.

VW 111

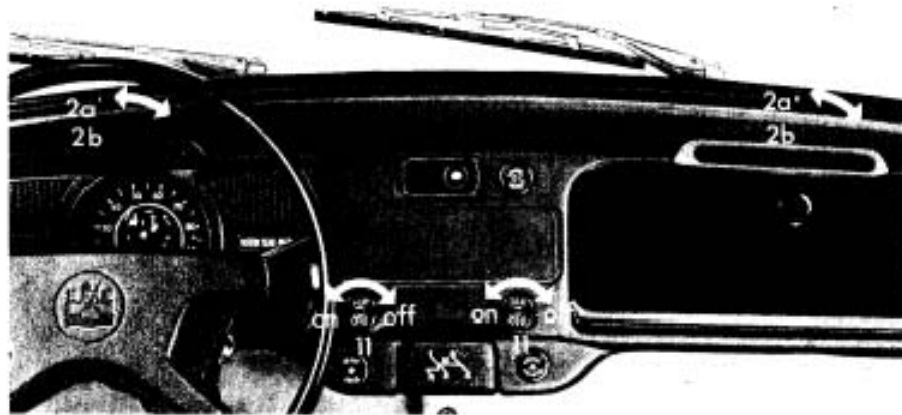

Convertible top

The convertible top should never be opened or closed while the car is in motion.

How to open the convertible top

The top should be dry before you open it.

- 1 - First release the locking levers on the sides above the windshield and fold the top back.
- 2 - Press down the top to engage the locking catches - 1 - on both sides.



Make sure the padding does not get caught under the fold-down stop - 2 - or in the linkage.

- 3 - Now take the covering boot (a separate cover that comes with every new VW Convertible) and slide it over the folded-down top. Tuck in the sides.

Fasten all snaps and rubber straps of the boot securely to the body.

How to close the convertible top

- 1 - The top should be dry before closing it. First take off the boot and turn down the rear windows. Press the top down lightly to disengage the locking

catches on both sides. Fold the top up and toward the front.

- 2 - From inside the car, grasp both levers and pull the top forward until the pins enter the guide holes on the windshield frame.
- 3 - Engage the hooks at the end of the lever into the grasping brackets above the windshield frame. Now lock the top tightly by pushing the levers upward.
- 4 - As a last step, open and close the rear windows to properly position the weatherstrips.

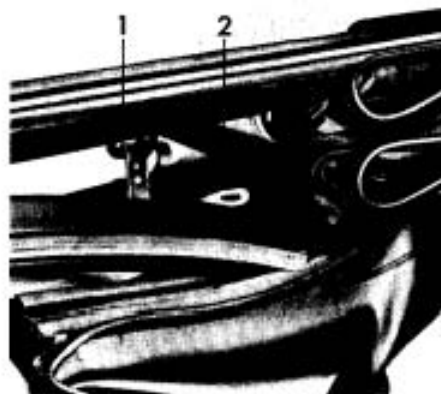

VW Auxiliary Heater (optional equipment)

Do not start or let the engine or heater run in an enclosed, unventilated area to warm up the car. Exhaust fumes from the engine or gasoline heater contain carbon monoxide, which is colorless and odorless. Carbon monoxide, however, is a very harmful gas, and may be fatal if inhaled.

To switch the heater on, depress the lower half of the rocker switch (VW 111: pull out the knob). This lights up a green indicator light in the rocker switch or in the knob.

The indicator light will also glow when the headlight switch is operated while the Heater is not in operation. This feature has been provided for easy recognition of the switch or knob in the dark.

To avoid an unnecessary drain on the battery, switch the heater off after about 25–30 minutes if the engine has not been started in the meantime.

A heat limit switch will turn the heater off periodically. The heater will come on again automatically within 3 minutes.

To switch the heater off, press on the upper half of the rocker switch (VW 111: push the knob in). The indicator light then goes out but the blower motor continues to run until the heater has cooled down.

The heater must be switched off when filling the fuel tank.

When it is very cold, the full battery capacity is required to start the engine. To

avoid starting difficulties, it is advisable not to preheat the vehicle interior under these conditions, that is, do not switch the heater on until the engine is running.

The heater normally requires no special maintenance. It is advisable, however, to have the heater plug checked once a year before the cold weather sets in and a new plug installed if necessary. The fuel system should also be checked for cleanliness and the electrical connections for tightness.

During the winter and when driving over very poor roads, mud or snow may tend to accumulate in the exhaust and combustion air intake pipes. Have these pipes checked for blockage from time to time so that the heater continues to work properly.

When the heater is not in use for long periods, for instance during the summer, the fuel in the heater can evaporate. It is therefore advisable to operate the heater briefly once a month when it is not in regular use.

Heat output: 8,000 BTU/h
Fuel: Gasoline from fuel tank
Fuel consumption:
appr. 0.7 pint/h (0.6 Imp. pint/h)
Current consumption: 40 watts

VW 113



VW 111



VW Air Conditioner (optional equipment)

The illustration shows a VW 113 equipped with an air conditioner. The controls and air discharge louvers for the air conditioner in the VW 111 are arranged in a similar way.

Operating controls

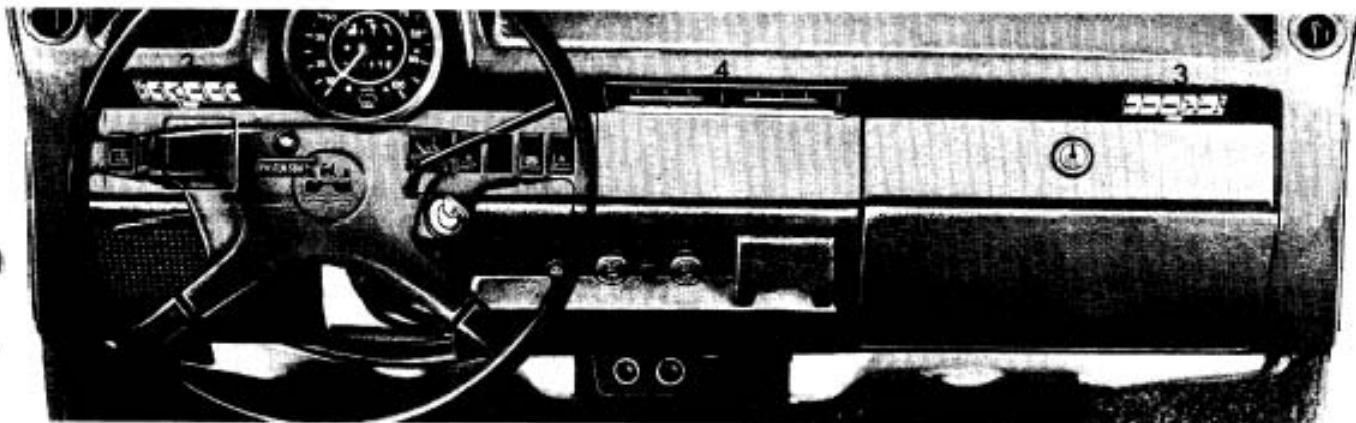

1 – Air volume switch ("FAN")

This switch serves two functions. It turns the air conditioning system on and off and controls the fan speed. The fan positions are:

- 1st position – **HIGH**
- 2nd position – **MEDIUM**
- 3rd position – **LOW**

2 – Air temperature control ("TEMP")

By progressively turning the control to the right, the desired cooling range can be selected. It is in the coldest position when turned as far as possible to the right.

3 and 4 – Air discharge louvers

Louvers – 3 – can be adjusted up or down with the small knob on the lower edge of the louver housing. The vane in the louver housing can be moved sideways to direct the conditioned air flow to the left or right. Louvers – 4 – and all louvers on the VW 111 can be adjusted up, down or sideways by moving the center vane.

Starting the Air Conditioner

With the windows and fresh air regulator closed, turn the air temperature control to the desired position and select the air volume speed desired. On extremely hot days turn the air volume to full capacity and open a window. Within a few minutes, the hot air will be forced out of the car and the window can be rolled up as cooling starts.

Adjust the air discharge louvers to the desired position.

Stopping the Air Conditioner

Turning the air volume switch to the "OFF" position stops the entire air conditioning system.

When restarting a stalled engine, it is not necessary to turn off the air conditioner. The current to the air conditioner is interrupted during the starting process.

Operational hints

If the car interior becomes too cold after adjusting the air volume, turn the air temperature control to the left until the desired comfort level is reached.

If the windows fog over on the **exterior** on warm, humid days, turn the air temperature control to the left until the windows clear up, or turn the windshield wipers on.

If the windows fog over on the **interior**, they can be quickly cleared by turning on the air conditioner.

During highway driving, set the air temperature control in approximately the middle position.

Maintenance hints

During the winter season, it is advisable to operate your Air Conditioner for a brief moment every week. This will help to keep the seals and fittings properly lubricated.

After the winter months and before extended summer usage, the air conditioner should be checked and, if necessary, serviced by an Authorized VW Dealer.

The condenser should be checked periodically for cleanliness. If clogged in any area with dirt or insects, the condenser should be washed down with water.

If the condenser fins are bent, the car should be taken to an Authorized VW Dealer for straightening of the condenser fins.

An air-conditioned Volkswagen should only be raised on a lift that provides adequate clearance to prevent damage to the refrigerant hoses.

Circuit breaker

An automatic resetting circuit breaker for the current supply of the air conditioning system is located under the rear seat. It is connected directly to the battery.

Note:

When a VW Air Conditioner is installed, the vehicle capacity weight will be reduced accordingly (see sticker on the inside of the glove compartment door).

Towing and trailer hauling

A – Towing

Your Volkswagen is equipped with two towing eyes, one at the front and one at the rear. They are for emergency towing over short distances only.

Rear

A towing eye is attached to the left rear bumper bracket.

Front

The **VW 113** and **VW Convertible** have a towing eye welded to the right-hand side of the frame head.

On the **VW 111**, a towing eye is welded to the right-hand side of the lower axle tube.

When towing your VW place the gearshift lever in Neutral. Turn the ignition on to be able to operate parking lights, turn signals and stop lights. Be sure to release the parking brake.

Always observe state laws and municipal ordinances governing towing.

Please keep in mind . . .

The towing eyes on your Volkswagen are not designed for towing by commercial tow trucks. Also, never have your VW towed by the bumper.

The driver of the towing car must be very careful when driving off and shifting to avoid sudden and abrupt jerks.

The driver of the towed car must always keep the tow rope taut.

B – Trailer hauling

It is possible to tow a trailer with your Volkswagen.

The total weight of a trailer (without brakes) should not exceed 882 lbs. The trailer tongue load should be 55 to 88 lbs.

Distribute load in the trailer evenly. And remember: the additional trailer weight affects the braking of your car so that a longer distance is needed to bring the car and trailer to a stop. Test the brakes before starting out on a trip with a trailer.

VW Automatic Stick Shift

If you plan to tow a trailer with the VW Automatic Stick Shift, have an ATF warning light installed on the dashboard

by your Authorized VW Dealer.

When towing a trailer, start out in the low driving range. Always shift to a lower range when driving up or down steep hills.

ATF warning light

Stop at once . . .

if the ATF warning light comes on. It indicates that the Automatic Transmission Fluid may have reached too high a temperature. This may be caused by stop-and-go traffic, mountain driving, etc.

Stop the engine and check the ATF level. If it is not as required, do **not** continue driving. Contact your nearest Authorized VW Dealer.

If you have enough ATF, you may continue driving, **but only in a lower driving range**. The ATF warning light should go out after a while when the ATF has sufficiently cooled down.

If the ATF warning light has come on while driving in **Low range**, stop the engine to permit the ATF to cool down. You may continue driving after the ATF warning light has gone out.

Winter operation

Your VW has an air-cooled engine. Do not, under any circumstances, try to influence the engine temperature by covering the louvers below the rear window or in the rear hood. These louvers must always be kept open so that air can flow to the carburetor and the engine cooling fan.

Battery

During the winter months, the battery is subjected to greater use than in the summer months. More current is consumed when starting at very low temperatures. Lights and the rear window defogger are used more often. Besides, the battery tends to decrease in capacity as the temperature drops.

Therefore, it is very important to keep your battery in the best possible condition. See also "Battery" on page 40.

Do not expose battery to open flame or electric spark as hydrogen gas generated by the battery is explosive. Do not let battery acid come in contact with skin, eyes, fabric or painted surfaces.

A really cold battery may not have the same capacity as a battery at normal temperature. If you mainly drive short distances or in city traffic, have the battery checked and, if necessary, charged between regular inspections.

Door locks

can freeze in the winter if water gets into them. When washing your car in the winter, do not aim the water jet directly at the locks. It is a good idea to put tape over the keyholes to prevent water from seeping in. Water in the locks must be removed with compressed air afterwards. Squirt lock de-icer, anti-freeze, or glycerine into the lock cylinders to prevent the locks from freezing.

To open a frozen lock, warm up the key before inserting it. It might also help to warm the lock. Do not use hot water as it will later freeze in the lock.

Emergency equipment

It is good planning to carry emergency equipment in your car. Some of the things you should have are: window scraper, snow brush, container or bag of sand or salt, flares, small shovel, first-aid kit, etc.

Engine oil

To make starting easier during the cold winter months, we suggest you choose a thinner grade motor oil. Turn to page 54 for the recommended oil grades.

If you drive mostly short distances and in city traffic, we recommend you have your engine oil changed at 1500-mile intervals in the winter.

Transmission oil

SAE 90 grade transmission oil can generally be used all year. Only in areas with a cold climate is it necessary to use the thinner SAE 80 transmission oil during the winter months.

In arctic climate and areas with temperatures consistently below -13° F, use Automatic Transmission Fluid (ATF) for the manual transmission and final drive. When the temperature rises, replace the ATF with SAE 80 or SAE 90 grade transmission oil. See also page 55.

Windshield washer

Add anti-freeze to the washer fluid, such as Volkswagen's Windshield Washer Anti-Freeze & Solvent, to prevent it from freezing. Follow the instructions on the can for the right amount to be used.

Spark plugs

Make sure the spark plugs are not worn or have a gap larger than 0.028 in.

For further details see page 49.

Tires

Your Volkswagen is equipped with tubeless bias ply tires. Volkswagen tires comply with all applicable U.S. Federal Motor Vehicle Safety Standards.

Tire pressures

For good car handling and long tire service life, it is important to maintain recommended tire pressures. Tires which are inflated above or below specifications can cause increased tire wear, increased gas consumption and affect the road holding of the car.

VW-recommended **cold tire inflation pressures** are listed on a sticker on the inside of the glove compartment door.

In the interest of safety, check the tire pressure of all tires, including the spare tire, at least once a week, and always before going on a long trip.

For road use do not exceed the maximum tire inflation pressure listed on the tire sidewall.

Spare tire pressure

Since the spare tire supplies the pressure to operate the windshield washer, the pressure of the spare tire should be between 29–42 psi (2.0–3.0 kg/cm²). This pressure level is only to be maintained for the operation of the windshield washer system. For road use, the pressure in the spare tire should be adjusted as specified on the sticker on the inside of the glove compartment door. See also page 34.

Tire rotation

If uneven tire wear should occur, we recommend that the tires be rotated as shown in the sketch below. Afterwards, the tire pressures must be corrected. The wheel bolts should be torqued diagonally to 87–94 ft. lbs. See also page 38.

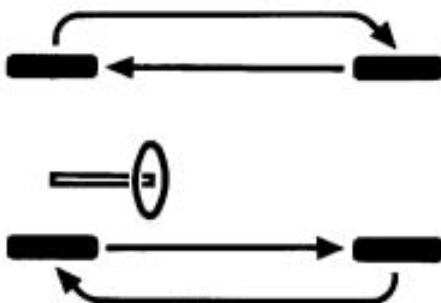

Wheel balancing

A wheel should always be balanced after a tire repair. Also, since regular use can cause tire imbalance, the wheels should be balanced from time to time. Unbalanced wheels may affect car handling and tire life.

Tire wear

The original equipment tires on your VW have built-in tread wear indicators. They are molded into the bottom of the tread grooves and will appear as approximately 1/8 inch bands when the tire tread depth becomes 1/16 of an inch. When the indicators appear in two or more adjacent grooves, it is time to replace the tires. We recommend, however, that you do not let the tires wear down to this extent. Worn tires cannot grip the road surface properly, and are even less effective on wet roads.

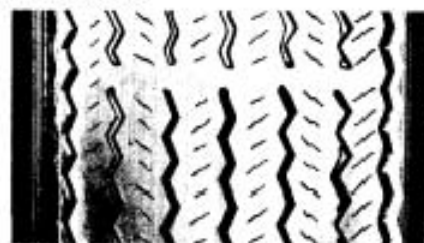

Indicator visible – tread worn

If you notice that tires are wearing unevenly, consult your Authorized VW Dealer. Uneven wear may not always be due to improper wheel alignment. It can be the result of individual driving habits such as cornering at high speeds. If the tire pressure is not checked and adjusted regularly, abnormal tire wear can also occur.

Do not drive with worn tires or tires showing cuts or bruises as they may lead to sudden deflation.

Tire replacement

In the interest of maximum safety and best all-around car handling, always buy replacement tires that show the same specifications with regard to tire size, design, load carrying capacity, tread pattern, etc. This also applies to VW-recommended alternate replacement tires.

Tire specifications are imprinted on the sidewall of the tires. If in doubt, check with your Authorized VW Dealer.

Replace all 4 tires at the same time. If this is not possible, replace tires in pairs, either front or rear.

New tires do not possess maximum traction. They tend to be slippery. Break new tires in by driving at moderate speed for the first 60–100 miles.

Winter tires

Winter tires give good traction in snow or slush.

For a better grip on hard snow or ice, you can use winter tires with studs, but **check with your State Motor Vehicle Bureau** for possible restrictions. Winter tires with studs should be run at moderate speed when new to give the studs time to settle.

Winter tires should preferably be mounted on all four wheels. They should also conform to the same load requirements as original equipment tires.

Inflation pressures for winter tires are listed on the sticker on the inside of the glove compartment door. **Do not exceed the maximum tire inflation pressure listed on the tire sidewall.**

Winter tires do not fulfill their purpose if the tread depth is less than $\frac{5}{32}$ " (4 mm).

For safety reasons, it is not advisable to drive with winter tires at top speeds. Winter tires do not have the same degree of traction on dry, wet or snow-free roads as regular tires.

Tire care

- 1 – Frequently check tires for damage. Remove imbedded material.
- 2 – Keep oil and gasoline away from tires.
- 3 – Replace worn tires in time.
- 4 – Replace missing valve dust caps as soon as possible.

Spare wheel

The spare wheel is under the front hood. To unlock the hood, pull the lever inside the glove compartment.

In the **VW 113**, the spare wheel is stored horizontally under the luggage compartment cover.



The spare wheel is connected to the windshield washer container and supplies the pressure to operate the washer. The air supply to the windshield washer will be interrupted automatically by a cut-off valve if the tire pressure drops to 26 psi (1.8 kg/cm²). This prevents the spare tire from being deflated below the required pressure.

In the **VW 111**, the spare wheel is stored in an upright position in the spare wheel well.

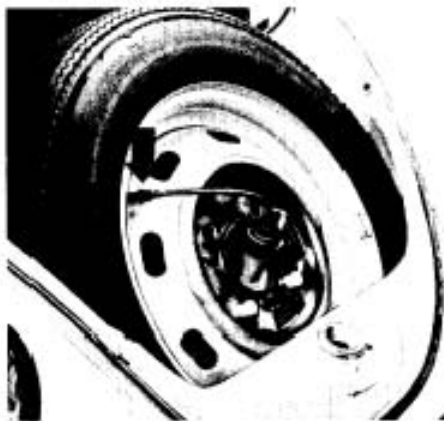

34

Check the tire pressure from time to time and maintain it up to a maximum of 42 psi (3.0 kg/cm²). This pressure level is only required for the operation of the windshield washer system. For road use, adjust the spare tire pressure as specified on the sticker on the inside of the glove compartment door.

To check or correct the pressure, first unscrew the hose from the valve near the filler cap of the windshield washer container (see also picture on page 33). The spare wheel is connected to this valve and can therefore be pressurized via this valve. Reconnect the hose to the valve after checking or inflating the spare tire.

On the **VW 111**, disconnect the windshield washer hose from the valve of the spare tire (see also left picture). Reconnect the hose after inflating or checking.

Jack

The jack is only to be used for changing a wheel. Do not use it as a support to work underneath the car.

The jack is located under the rear seat next to the battery. It is held in stowage position by a clamp. To take out the jack, take out the rear seat (see page 45) and lift the clamp. Before putting the jack back in again, wind it down sufficiently. Tighten the clamp.

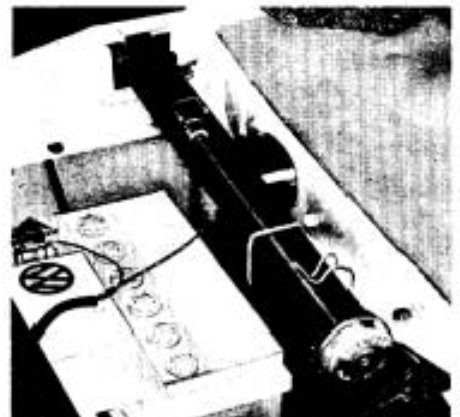

Changing a wheel

If you have a flat tire, **move off the road. Turn on the emergency flasher. In addition, mark the position of your car with flares or other warning devices to alert other motorists.**

Before you change a wheel, be sure **the ground is level and firm, especially near the rear wheels where the jack ports are.**

Set the parking brake and block the wheels opposite the defective wheel on the other side of the car.

For a more efficient and safe changing of a flat tire, observe the following 10 steps.

Further on, we expand on these steps in greater detail.

- Step 1 – Take out tools, jack and spare wheel.
- Step 2 – Remove hub cap.
- Step 3 – Loosen wheel bolts. **Do not take them out.**
- Step 4 – Securely insert the jack in jack port. There is **one** for each side. It is under the running board toward the rear, and is used for front or rear wheel changing.

Never jack the car up by the bumper or the running board.

Step 5 – Jack up car.

Step 6 – Change wheel and handtighten wheel bolts.

Step 7 – Lower car.

Step 8 – Further tighten the wheel bolts.

Step 9 – Replace hub cap.

Step 10 – Torque and air pressure adjustment.

Step 1

Take out your tool kit.

Take out the **jack** from under the rear seat next to the battery. Take the rear seat out (see page 45) and lift the clamp that is holding the jack in stowage position.

Before you take out the **spare wheel** from under the front hood, disconnect the hose leading to the windshield washer container (large arrows – see right picture on this page and left picture on page 36).

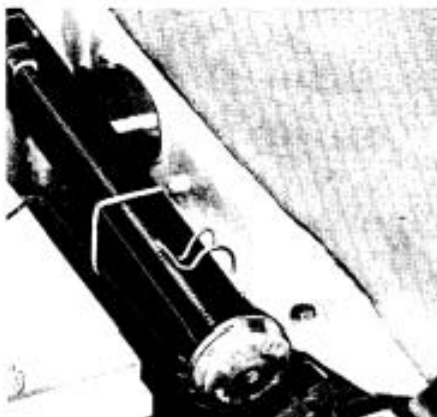

In the **VW 111**, lift the **spare wheel** up and place it on the edge or bumper. This way you have better access to the two wedges (small arrows), that hold the washer container in the rim. Remove the wedges and separate the container from the wheel.

Step 2

With the wheels still firmly resting on the ground, remove the hub cap of the defective wheel.

Insert the puller in the holes at the rim of the hub cap. Put the breaker bar through the puller, brace one end of the bar on the wheel rim and tug lightly on the other end.

When you place the hub cap face down, you can use it as a tray for your wheel bolts.

Step 3

Loosen all wheel bolts counterclockwise about one turn with the socket wrench. Insert the breaker bar to make full use of its leverage. **Do not yet remove the bolts.**

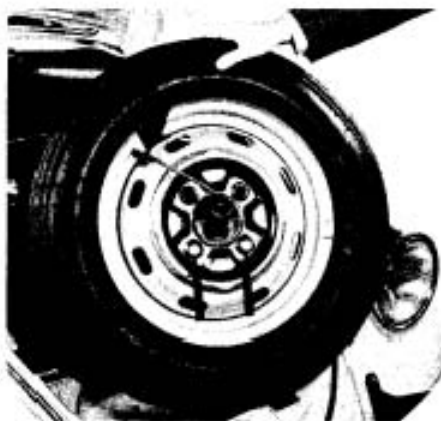

Step 4

Securely insert the jack into the jack port. There is one on each side under the running board toward the rear and is used for front and rear wheel changing. **Never jack the car up by the bumper or running board.**

Provide for a **firm base for the jack on the ground.** If necessary, use a board.

Passengers should not remain in the car when the car is jacked up.

Step 5

Do not raise the car until you are sure the jack is securely engaged.

To raise the car, turn the handle clockwise.

To get the jack as vertical as possible, push the upper part of the jack toward the body while you are jacking up the car.

Only raise the car as much as is needed to change a wheel.

Step 6

Fully unscrew the wheel bolts and place them into the hub cap. Place the spare wheel against the brake drum so that the bolt holes in the wheel are in line with the threaded holes in the brake drum. Insert the wheel bolts and handtighten them crosswise before jacking the car down.

Step 7

To lower the car, turn the handle counterclockwise.



Step 8

Then go crosswise from one bolt to another, tightening them firmly with the socket wrench and breaker bar.

Step 9

To install the hub cap, place it around the lower part of the wheel center, and with a firm push on the upper part, the hub cap will snap into place. Make sure it is properly seated.

Step 10

Correct tightness of the wheel bolts is important.

Correctly tightened bolts should have a torque of 87–94 ft. lbs. This torque can be obtained with socket wrench and breaker bar by any person of average strength. If in doubt about the correct tightness of the wheel bolts, have it checked with a torque wrench by your dealer or a service station.

Also, correct the **pressure of the tire** you have just put on.



Container for windshield washer fluid (1)

The windshield washer container has a capacity of 3.6 US pints (3.0 Imp. pints). To add washer fluid, just unscrew the filler cap. The container can be filled to the top.

As clear water is usually not adequate for cleaning the windshield, add a cleaning solution to the water such as Volkswagen's Windshield Washer Anti-Freeze & Solvent. It is a concentrate, so follow the directions on the can for the correct amount to be used.

You can use Volkswagen's Windshield Washer Anti-Freeze & Solvent all year. It helps to keep your windshield clean, and prevents freezing of the washer fluid in the winter.

Since the spare tire supplies the pressure to operate the washer, it should always be kept up to a pressure of 42 psi (3.0 kg/cm²). To pressurize the spare tire, see page 34.

Brake fluid reservoir (2)

The brake fluid should always be above the seam edge near the top of the reservoir. If it drops below this point, the cause should be corrected by your Authorized Volkswagen Dealer.

Every 2 years, the brake fluid has to be replaced.

See "Scheduled Maintenance" on page D 6 and "Additional Services Record" on page D 10.

Only **new, unused** brake fluid that meets the SAE recommendation J 1703 and conforms to Motor Vehicle Safety Standard 116 must be used.

VW 111



Battery

The battery is under the rear seat on the right, as seen in driving direction. Just take the rear seat out (see page 45).

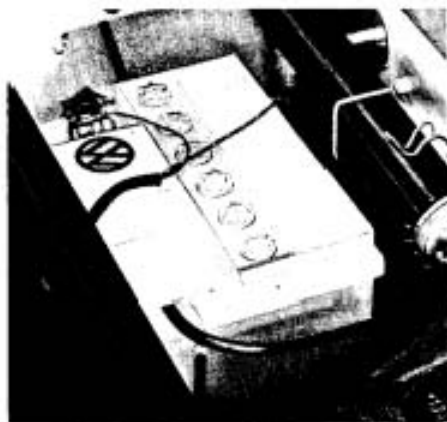

The electrical system depends mainly on the battery. Therefore, the battery should be checked regularly and kept in good working condition.

Never drive the car with a disconnected battery as this may damage the electrical system.

Do not expose the battery to an open flame or electric spark. Hydrogen gas generated by the battery is explosive. Do not let battery acid come in contact with skin, eyes, fabric, or painted surfaces.

Each filler plug has to be unscrewed to check the fluid level in each cell. If it is **below** the indicator, top it up with distilled water. **Only fill up to indicator.**

How often water must be added to the battery depends mainly on operating conditions and on the time of year. As a general rule, the battery electrolyte level must be checked more often in the summer than in the winter, and more often when driving long distances.

The terminals and connections should be kept clean and greased with silicone spray or petroleum jelly. Make sure the ground connection to the body is tight and free of corrosion.

When working on the battery, be sure not to short circuit the terminals. This would cause the battery to heat up very quickly, which could lead to damage.

Before having a quick-charge performed on a battery installed in a car, **disconnect both terminals to avoid serious damage to the electronic components of the electrical equipment.**

If you have not used your car for an extended period of time, have the battery recharged.

Fuel supply

In the interest of cleaner air, the VW engine is designed to run also on low-lead or lead-free gasoline.

The engine requires "Regular" gasoline. The minimum octane rating is shown on the label on the inside of the fuel tank flap. If regular fuels with adequate anti-knock qualities are not available, premium fuels should be used or mixed with regular fuel. This might be necessary when traveling outside the United States or Canada.

The Auxiliary Heater (optional equipment) must be turned off when filling the fuel tank.

Never start or let the engine run in an enclosed unventilated area. Exhaust fumes from the engine contain carbon monoxide which is colorless and odorless. Carbon monoxide, however, is a very harmful gas, and can be fatal if inhaled.

Fuses

The filler neck to the fuel tank is behind a flap on the side panel above the right front fender. A finger moulding makes opening and closing the flap easier.

The fuel tank has a capacity of 11.1 US gallons (42 liters or 9.2 Imp. gal.). The VW 111 has a tank capacity of 10.6 US gallons (40 liters or 8.8 Imp. gal.).

When putting the cap back on, turn the threaded filler cap until you hear a click.

The 12-point fuse box is located under the instrument panel.

When a fuse is blown, it is not sufficient to merely replace it. The cause of the short circuit or overload must be found. On no account should fuses be patched up with tin foil or wire as this may cause serious damage elsewhere in the electrical circuit. It is advisable to always carry a few spare 8 amp. and 16 amp. fuses in your car.

To replace a fuse, simply depress a contact on either side of the fuse.

There are ten 8 amp. fuses (white) and two 16 amp. fuses (red). No. 9 and No. 10 are the two 16 amp. fuses.

| Model | 111 | 113 |
|----------------------------------|-----|-----|
| Parking and side marker lights, | | |
| License plate light, Tail light, | | |
| right | 1 | 2 |
| Tail light, left | 2 | 1 |
| | 3 | 4 |
| | 5 | 6 |
| | 7 | 8 |
| | 9 | 10 |
| | 11 | 12 |

| Model | 111 | 113 |
|---|-----|-----|
| Low beam, left | 3 | 3 |
| Low beam, right | 4 | 4 |
| High beam, left | 5 | 5 |
| High beam indicator light | 6 | 5 |
| High beam, right | 6 | 6 |
| Accessories | 7 | 7 |
| Emergency flasher system | 8 | 8 |
| Buzzer | 9 | 8 |
| Interior light | 9 | 9 |
| Windshield wipers, Rear window defogger (switch current) | 10 | 10 |
| Fresh air fan | - | 10 |
| Horn, Stop lights, Control valve* and ATF warning light** (Automatic Stick Shift) | 11 | 11 |
| Fuel gauge, Turn signals, Brake warning light, Warning lights for oil pressure, turn signals and alternator | 12 | 12 |

* If this fuse is defective, the transmission cannot be shifted.

** Trailer hauling only.

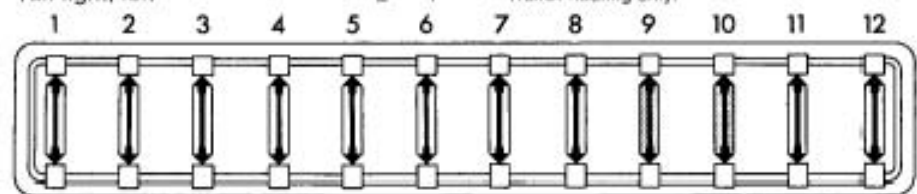

⇔ 8amp.

⇔ 16amp.

Additional fuses

| Electrical equipment | Fuse | Location of fuse holder |
|---------------------------------------|---------|---|
| Back-up lights | 8 amp. | In the engine compartment above the ignition coil (A) |
| Rear window defogger (main current) | 8 amp. | Underneath the rear seat on the left (B), (as seen in driving direction). |
| Auxiliary heater (optional equipment) | 16 amp. | In the front luggage compartment near the heater (C) |

To replace a fuse in an inline fuse holder, pull the holder out of the clip, where necessary. To open the holder, grasp both ends of the holder, press lightly together and twist counterclockwise. Install fuse. To close the holder, put both ends together again, press lightly and twist clockwise.

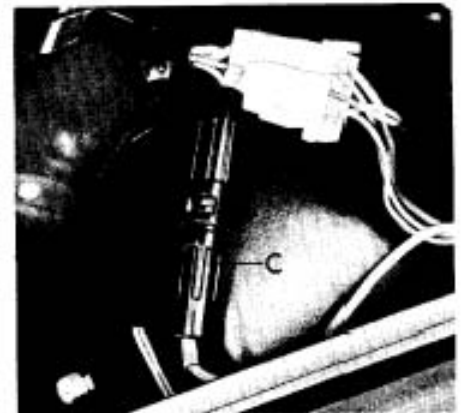
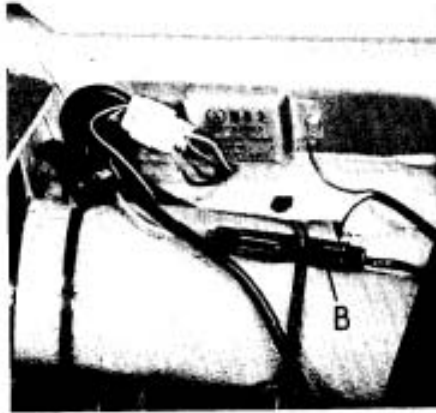
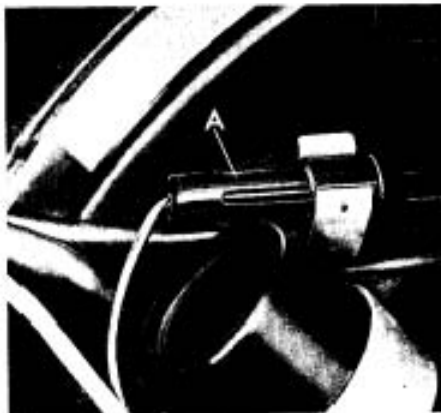

Cleaning your VW

The paint on your VW is very durable, and so is the upholstery. But a car can get a lot of abuse from industrial fumes and corrosive road salt to half-eaten lollipops and muddy dog feet.

A well-cared-for VW can look like new 10 years later. It all depends on the owner and the amount of care he is willing to give to his car.

Here are a few hints on how to keep your VW looking young and beautiful. We have also compiled a list of cleaning products. They are available at any VW Dealer.

Whenever using VW-recommended products or other cleaning agents, **follow the directions on the containers. Be aware of warning or caution labels.**

Washing your VW

The longer the dirt is left on the paint, the greater the risk of damaging the glossy finish, either by scratching if the dirt is rubbed into the paint, or simply by the chemical effect dirt particles have on the paint surface.

Therefore dirt should be washed off as soon as possible. **NEVER WASH IN DIRECT SUNLIGHT.**

Use plenty of water, a car-wash soap, such as VW's Car Wash and Wax, and a

| Application | Volkswagen Product |
|--|---|
| Car wash and liquid wax | Car Wash and Wax – ZVW 243 201 |
| Paint preservative | Paint Preservative and Wax – 000 096 011 |
| Paint waxing | Classic Car Wax – ZVW 246 101 |
| Paint polishing and paint waxing | Combination Car Cleaner and Wax – ZVW 241 109 |
| Paint polishing, remove paint oxidation | Paint Polish – 000 096 001 |
| Preservation of chrome parts | Chrome Preservative – 000 096 067 |
| Paint touch-up | Touch-Up Paint (all colors) |
| Convertible top cleaning, Upholstery cleaning, Whitewall tire cleaning | All Purpose Cleaner – ZVW 243 101 |
| Windshield cleaning and washer anti-freeze | Windshield Washer Anti-Freeze & Solvent – ZVW 241 101 |

soft sponge or hose brush. Begin by spraying water over the dry car to remove all loose dirt before applying the lukewarm soap/water solution.

Use plenty of water to rinse the car off. Wipe the car dry with a chamois to avoid water spots.

Waxing

Waxing is not really needed when you have washed your car with VW's Car Wash and Wax. If you do not use a car wash liquid with wax, apply Paint Preservative and Wax to preserve the natural shine of the car.

To obtain a long lasting wax finish apply hard wax, such as VW's Classic Car Wax, eight to ten weeks after buying the car. Wax again when water remains on the surface in large patches instead of forming beads and rolling off.

Polishing

Use a polish such as VW's Paint Polish later in the car's life when the paint appears dull and loses its shine. **Do not polish the new car.**

Always apply wax after polishing.

Cleaning windows

Clean windows with a sponge and warm water. Dry with a chamois.

Weatherstrips

To seal properly, weatherstrips around windows and doors must be pliable. To retain flexibility of the rubber, spray with silicone, available from your VW Dealer, or coat with talcum powder.

Windshield wiper blades

Remove the wiper blades periodically and scrub with a hard bristle brush and alcohol or a strong detergent solution.

Chrome care

To protect the car's chrome, apply VW's Chrome Preservative.

Touch-up paint

Your dealer has touch-up paint for minor scratches and stone chips. Scratches should be touched up soon after they occur.

Care of chassis

The underside of the car picks up dirt and salt and should be sprayed with a powerful jet of water. This is easier to do after the car has been driven in rain.

Removing spots

Do not use gasoline, kerosene, naphtha, nail polish remover or other volatile cleaning fluids. They may be toxic or flammable or hazardous in other ways. Only use spot removing fluids in well ventilated areas. Keep them out of reach of children.

Tar

Do not allow tar to remain on the paint finish. Remove it as soon as possible with a cloth soaked with a special paint cleaner, such as Paint Preservative and Wax. If you do not have a spot remover, you may substitute with turpentine. After applying a cleaning fluid, always wash with a lukewarm soap/water solution and apply a new wax coat.

Insects

Remove as soon as possible with a lukewarm soap/water solution or apply insect remover.

Tree sap

Remove with a lukewarm soap/water solution. Do not allow tree sap to harden on the paint surface.

Cloth upholstery and carpet

Clean with a vacuum cleaner or a hard bristle brush. Dirt spots can usually be removed with a lukewarm soap/water solution.

Use spot remover for grease and oil spots. Do not pour the liquid on the

cloth material. Dampen a clean cloth and rub carefully, starting at the edge and working inward.

Leatherette and interior trim

Use VW's All Purpose Cleaner or a dry foam cleaner.

Grease or paint spots can be removed by wiping with a cloth soaked with VW's All Purpose Cleaner. Leatherette parts of the headliner and side trim panels can be cleaned with a soft cloth or brush and All Purpose Cleaner.

Cleaning the convertible top

The top does not require any special care. Wash off dirt as soon as possible.

Do not wash in direct sunlight. Use lukewarm water together with VW's All Purpose Cleaner. A hard bristle brush will help to loosen dirt from the grained surface of the material. Avoid scratching the body of the car with the bristles.

To remove spots, use a stronger solution of VW's All Purpose Cleaner. Never use paint thinner, nail polish remover or similar agents as they may have adverse effects on the top material.

After cleaning and washing the top, rinse the car well with clear water.

Clean the **pivoted points of the top linkage** from time to time, and lubricate them lightly with a few drops of oil. Wipe off excessive oil to prevent oil from dripping on the top material.

Removing and installing rear seat

Do this through the passenger's door. Raise the front edge of the seat and pull it slightly toward you. Reposition the safety belts. For easier removal, tilt the right side of the rear seat up (as seen in driving direction).

When doing this, be careful not to damage the backrest with the retaining hook on the rear edge of the seat cushion. Position the seat diagonally and take it out through the right door.

When putting the seat back in again, follow the same steps in reverse order. Lift the seat into the car through the passenger's door, holding the seat diagonally with the right end of the rear seat tilted up. With the front end of the seat tilted up, slide the seat fully back under the backrest to engage the retaining hook. Position the safety belts on top of the seat cushion. Press down the front edge of the seat to firmly position it in place.



Bulb chart

| Bulb for | US Replacement bulbs | VW Part No. |
|--|----------------------|-------------|
| Sealed beam (headlights) | 6014 | ZVP 118 114 |
| Front turn signal/parking lights | 1034 | ZVP 118 034 |
| Side marker lights | 57 | ZPP 118 057 |
| Rear turn signal | 1073 | ZVP 118 073 |
| Stop lights | 1073 | ZVP 118 073 |
| Tail lights | 67 | ZVP 118 067 |
| Back-up lights | 1073 | ZVP 118 073 |
| License plate light | 89 | ZVP 118 089 |
| Instrument and indicator lights | — | N 17 722 2 |
| Warning lights for emergency flasher and brake operation, indicator lights for rear window defogger and Auxiliary Heater | — | N 17 751 2 |
| Spot light for heater levers | — | N 17 751 2 |
| Interior light: Sedans | 211 | N 17 723 2 |
| Convertible | — | N 17 725 2 |

Replacing bulbs

Headlights

Your Volkswagen is equipped with double filament seven inch sealed beam units. Should it become necessary to replace a unit, loosen screw in the center of the trim ring below the headlight and take off the trim ring:

Firmly grasp the loose screw - a - (non-removable) and pull trim ring off.

Remove three short screws - b - in sealed beam retaining ring and take ring off.

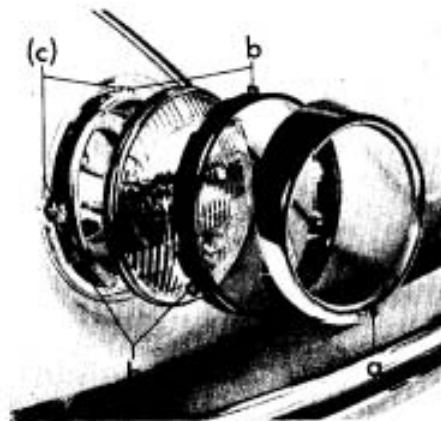

46

Do not alter the position of the long headlight adjustment screws (- c -).

Take sealed beam unit out of support ring and pull cable connector off.

When installing new sealed beam units, be sure the three glass lugs engage properly in the support ring.

Before installing trim ring be sure the rubber gasket is in place. Loosely insert the screw for the trim ring and turn for 2 or 3 turns.

Position edge of trim ring over upper lug. Press ring over lug and tighten screw.

If no other headlight part as described here was removed or its position changed, it should not be necessary to aim the headlights. If in doubt have the adjustment checked at your dealer.

Front turn signal/parking light bulb or side marker light bulb

Remove two Phillips screws. Take off housing and lens.

Gently press bulb into holder, turn and take out.

Install new bulb.

Be sure the gasket is properly positioned when reinstalling the housing and lens.

Tighten screws evenly. Do not over-tighten as this may crack the lens.

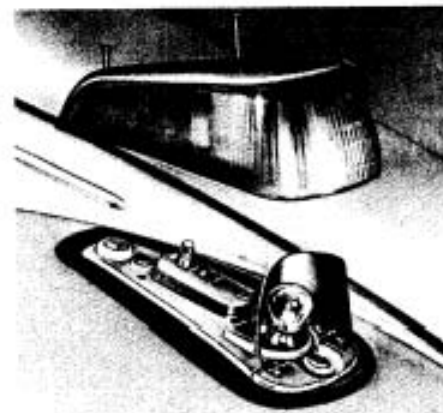

Rear turn signal, stop/tail light or back-up light bulb

Unscrew four Phillips screws and remove lens.

Bulb positions:

- a – turn signal light
- b – stop light
- c – tail light
- d – back-up light

Gently press bulb into holder, turn and take out. Install new bulb.

Be sure the gasket is properly positioned when reinstalling the lens. Tighten screws evenly. Do not overtighten as this may crack the lens.



License plate light bulb

Open rear hood.

Remove screws on each side of lens and take off lens with bulb holder.

Pull bulb holder out of lens.

Gently press bulb into holder, turn and take out.

Install new bulb.

When installing, ensure that the cable grommet fits properly.

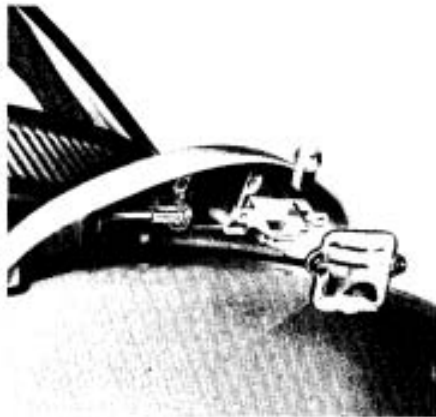

Interior light bulb

Insert screwdriver in housing cut-out on the switch side and carefully pry out.

Take bulb out.

Install new bulb.

Insert housing in reverse order.

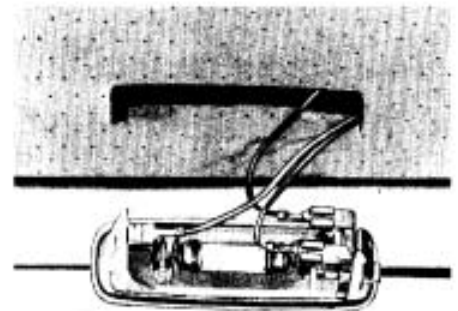

General services

Before working on any part in the engine compartment, turn off the engine and let it cool down sufficiently. If work has to be done with the engine running, exercise extreme caution to prevent neckties, jewelry or long hair from getting caught in the V-belt.

Incomplete or improper servicing may cause problems in the operation of the car. If in doubt about any servicing, have it done by your Authorized VW Dealer or any other properly equipped and qualified workshop.

Adjusting or replacing V-belt

Turn the engine off!

To adjust the belt, remove the rear half of the pulley on the alternator. When loosening and tightening the nut, place a screwdriver through the cut-out in the front half of pulley and support the screwdriver as shown in the picture.

The belt tension is adjusted by varying the number of washers between the pulley halves. Taking washers out increases the tension, putting them in decreases it. Extra washers are stored on the outside of the pulley half.

48

The V-belt must not be too tight or too loose when you are making the following belt tension check: Depress one side of the belt at the center between the two pulleys. The tension is correct if the belt can be depressed between 0.43 ($\frac{7}{16}$) in. and 0.55 ($\frac{9}{16}$) in. at a pressure of 16.5 lbs. (a firm press with your thumb).

A new belt may stretch slightly at first. To compensate for this, the belt should be tightened slightly more when first installed. The deflection should be between 0.35 ($\frac{11}{32}$) in. and 0.43 ($\frac{14}{32}$) in. at the same pressure. The correct belt

tension will then be reached after about 30 minutes of operation. If in doubt, have the belt tension checked and adjusted by your VW Dealer.

The heavy-duty V-belt has a very low stretch factor. When properly installed, the belt tension will remain fairly constant. Volkswagen-recommended V-belts have a relatively long service life, however, it is good planning to always carry a spare belt in your car.

For the correct designation on the belt, see page 63.

a - to loosen b - to tighten

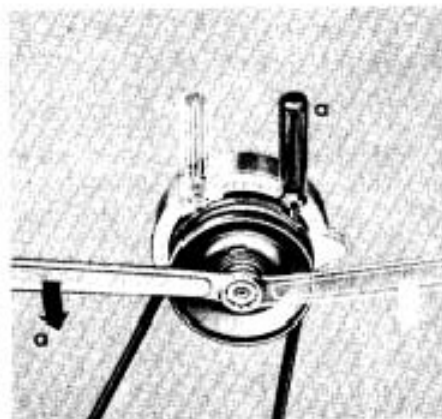

Cleaning or replacing spark plugs

The correct spark plug gap is 0.028 inch. Since the spark plug gap tends to increase in time during normal operation, it is advisable to replace spark plugs every 12,000 miles.

Removing spark plugs

Grasp the spark plug connector and pull it off. Do not pull on the ignition wires as they may separate from the connectors.



Unscrew the spark plugs with a suitable spark plug wrench.

Cleaning spark plugs

Dirty spark plugs should be cleaned with a sand blaster, but if not available, the carbon can be removed with a wooden or plastic pick. Do not use a wire brush. The plugs should also be clean and dry on the outside to avoid shorting and arcing. **The gap can be set by bending the outside electrode. The gap should be 0.028 inch.**

Installing spark plugs

Insert them by hand and screw them into the cylinder head as far as they will go. Only then use the spark plug wrench to tighten them firmly. Do not overtighten.

Checking the engine oil level

Your VW will usually not need additional oil between the scheduled changes.

Even so, you should check the oil level from time to time. To get a true reading, be certain the car is on level ground.

Wait at least 5 minutes after the engine has been stopped; give the oil time to collect in the crankcase.

To check the oil level, take the dipstick out and wipe it clean first. Now, insert and pull it out again. You have enough oil in the engine if the oil level is between the upper and lower marks on the dipstick.

Only add the amount of oil that is needed.

Always select a well-known brand and the recommended grade. Details about the correct oil viscosities are on page 54.



Changing the engine oil

Change the oil in your engine at least every 3,000 miles. This is very important as the lubricating properties of oil diminish gradually during normal operation of the car.

Drain the oil when the engine is still warm. Loosen all six cap nuts. Then, after removing five of the nuts, pry the oil strainer cover loose. Allow the oil to drain.

After the oil is drained, remove the oil strainer to clean it. The cleaning of the strainer should be done with every oil change. Use new gaskets and copper washers when re-installing the strainer to be sure no oil leak will develop later.

Fill the engine with 5.3 U.S. pints (4.4 Imp. pints) of oil labeled "For Service SD" or "SE" (or combination). For the right oil viscosity, see page 54.

Because of detergent additives in the oil the fresh oil will look dark after the engine has been running for a short time. This is to be expected, and there is no reason to change the oil at intervals shorter than 3,000 miles.

We recommend more frequent oil changes (every 1,500 miles) if you drive your car only short distances during the winter months. If you drive for only a few hundred miles a month under these con-



ditions, we advise you change the oil every 6 to 8 weeks. In areas with arctic climate where average temperatures are below -13° F, the oil should be changed every 750 miles.

Manual Transmission oil

Both transmission and final drive are combined in one housing. The lubricant used is hypoid oil that is changed by your dealer only one time at 600 miles as part of the lubrication service. See page D 2.

Should the need arise to add oil, it should only be done with the necessary workshop equipment. Also hypoid oil is generally not marketed in small quantities.

Automatic Transmission Fluid

On vehicles with Automatic Stick Shift, the ATF in the torque converter does not have to be changed, but the level should be checked every 6,000 miles, **with the engine turned off.**

An ATF tank filler with a dipstick attached to its cover is provided for this purpose on the right side in the engine compartment.

Wipe the dipstick clean first before inserting it to take a level reading. The fluid level should be between the two marks on the dipstick, and should never fall below the lower mark. Only add the required amount of ATF. Check for leaks.

For ATF specifications, see page 55.



Air Cleaner

All the dust present in the air drawn in by the engine is retained by the filter element in the air cleaner.

A dirty filter element not only reduces the engine output but can also cause premature engine wear. If local conditions are such that the vehicle is often driven on very dusty roads, the cleaner must be serviced frequently, even daily if necessary.

Under normal conditions it is not necessary to service the filter element more frequently than is mentioned in the Diagnosis and Maintenance Service.

To clean or to replace the filter element, the air cleaner must be removed. Do the following:

For easier reinstallation note the hose attachments; interchanging of hoses affects the operation of the engine.

Pull off hoses A through C (hose C directly behind B).

Loosen clamp – D – and pull hose off.

Loosen screw – E – of air cleaner clamp and remove air cleaner from carburetor.

Release the four clips – F – and take top part of air cleaner off.

Take the filter element out and clean or replace it. Remove the dirt by shaking the filter element out, with the dirt-trapping side down.

Note

Under no circumstances may the paper element be cleaned or soaked with gasoline, cleaning solvents or oil.

When installing the air cleaner, make sure the element is properly seated and the gap between the air cleaner and fan housing is even.

Tighten the air cleaner clamp screw – E – carefully, but do not overtighten it.

Make sure all hoses are properly connected.

Note

On the Automatic Stick Shift, be sure to position the green hose for the vacuum spark advance and the black hose for the intake air pre-heating, before closing the left rear clip F.

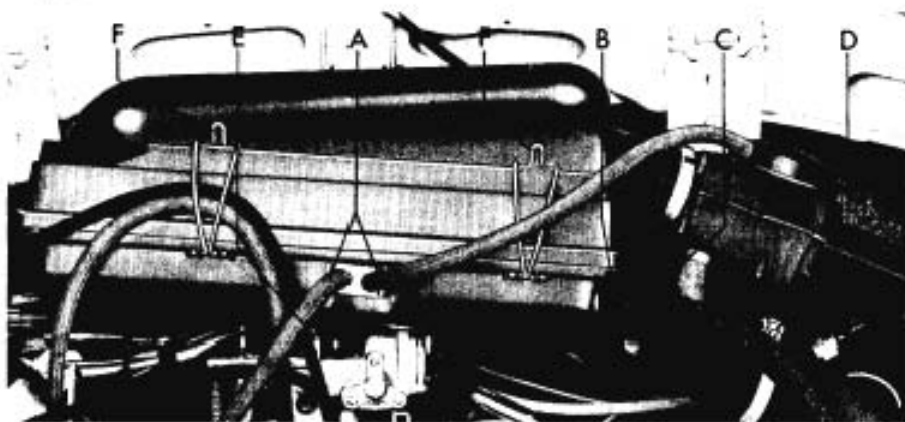

Lubrication

Front axle

(Applies to the Volkswagen Sedan 111 only. The front axle of the Volkswagen Sedan 113 and the Convertible does not have to be lubricated.)

Lubricate the front axle once a year or every 18,000 miles (see VW Diagnosis and Maintenance Schedule).

Lift the front end of the car to take the weight off the front wheels. This is necessary to free the bearings to accept the lubricant. There are 4 grease fittings for the front axle. For their location, see arrows in the illustration.

Before forcing grease into the fittings, be sure to wipe them clean with a piece of cloth. Force lithium-based multi-purpose grease into the fittings until fresh grease starts to emerge at the torsion arm sealing rings.

Wipe off any grease or oil that may have come in contact with tires or brake hoses because grease and oil have an adverse effect on rubber.

Door hinges and locks

The door hinges have to be lubricated every 6,000 miles. Your Authorized VW Dealer uses a grease gun with a tapered nozzle.

If upon inspection the door locks are not working properly they should be lubricated with a few drops of oil after the plug has been removed from the access hole.

To lubricate the lock cylinder dip the key into graphite, insert it and turn it a few times in the lock.

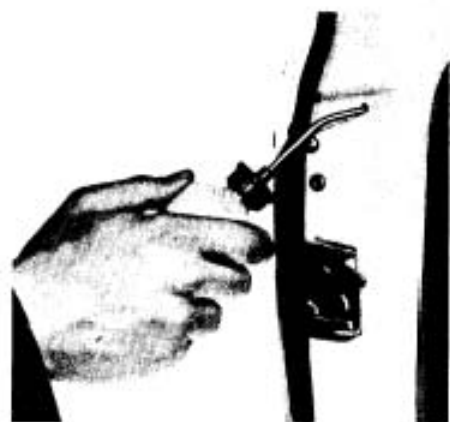
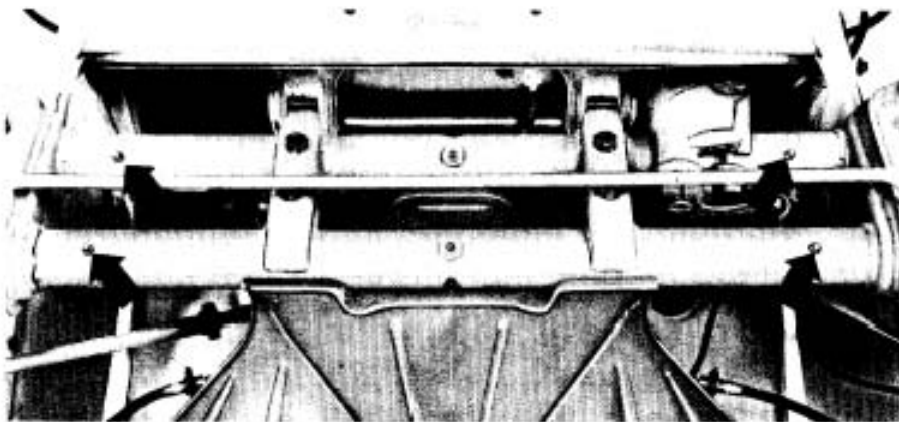

Engine oil

Always use a name brand oil labeled "For Service SD" or "SE" (or combination) for the engine of your Volkswagen.

Engine oils are graded according to their viscosity. The proper grade to be used in your engine depends on existing climatic or seasonal conditions.

The following table contains the grading for oils to be used in VW engines:

| | | | |
|------------------|-------------|---|-----------|
| Tropical climate | Hot season | | SAE 40 |
| | Cool season | | SAE 30 |
| Moderate climate | Summer | | |
| | Winter | At average outside temperature above 5° F | |
| | | At average outside temperatures not lower than —13° F | SAE 10 W* |

If outside temperatures are continuously below —13° F use SAE 5 W*

* Avoid high speed long distance driving when using SAE 10 W or SAE 5 W if outside temperatures rise above the indicated limits.

As temperature ranges of the different oil grades overlap, **brief** variations in outside temperatures are no cause for alarm. It is also permissible to mix oil of different viscosities if you find it necessary to add oil.

Temperature ranges of SAE grades

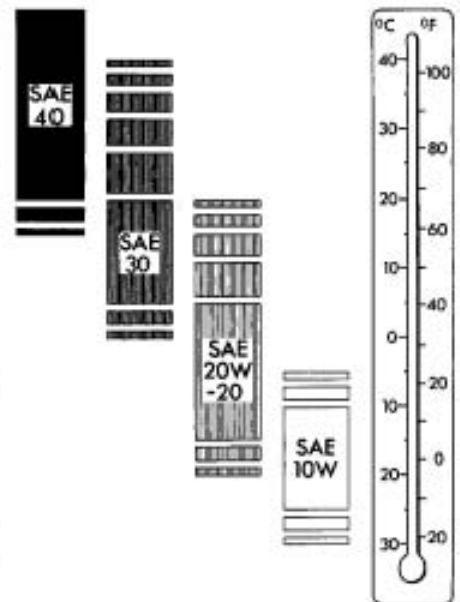

Transmission oil and Automatic Transmission Fluid (ATF)

Transmission and final drive are both lubricated with hypoid oil according to Mil-L-2105-B specifications (additive basis: sulphur-phosphorus):

SAE 90 In general all year.

SAE 80 In areas with cold climate.

ATF In areas with arctic climate and temperatures consistently below -13° F.

ATF is a special fluid for automatic transmissions, but ATF can also be used in the Manual Transmission under the above mentioned climatic conditions.

The torque converter of the Automatic Stick Shift requires ATF all year.

All ATF's labeled "Dexron®" with a five-digit number preceded by the letter "B" can be used.

Lubricant additives

If a VW engine is properly maintained, it is uneconomical to mix any type of additive with fuel, or lubricating oils and transmission fluids.

Grease

- 1 – **Multi-purpose grease with a lithium base** should be used for the front axle of the Volkswagen Sedan 111 and for the door hinges on all beetle-type VW models.
- 2 – **Dry stick lubricant** should be used for the hood locks and the sliding surfaces of the striker plates.
- 3 – **Silicone spray or petroleum jelly** should be used for the battery terminals and posts.

Troubleshooting

Your Volkswagen should repay you with trouble-free driving if it receives regular maintenance.

Should you ever encounter difficulty in starting your engine or have trouble on the road, there are a few simple repairs which you can make to get your VW going again. Locate the problem and probable cause of the trouble in the guide on the following pages and follow the directions on what to do.

Exercise extreme caution when working on any part of the car to prevent accidental injury. Incomplete or improper servicing may also cause problems in the operation of the car. If in doubt about any servicing, have it done by a qualified mechanic or by your Authorized VW Dealer.

Note: The adjustment of idling and ignition timing requires special equipment and training. We suggest that you consult your Authorized VW Dealer.

| Problem | Probable Cause | What To Do |
|---|--|---|
| VW will not start; engine will not turn over or turns over too slowly | <ol style="list-style-type: none"> 1. Run down or dead battery 2. Loose connection <ol style="list-style-type: none"> A. At battery B. At starter C. At connections behind dash board 3. Starter defective 4. On vehicles with Automatic Stick Shift: The gear shift lever is not in Neutral | <ol style="list-style-type: none"> 1. Charge or replace battery. 2. Make sure that all connections are tight. <ol style="list-style-type: none"> A. Check both cable connections on battery and grounded end of ground strap. B. Check connections at solenoid, mounted on starter, under right rear of vehicle. C. Check push-on connectors behind dash board. 3. See your nearest Authorized VW Dealer. 4. Shift to Neutral. |
| VW will not start; engine turns over | <ol style="list-style-type: none"> 5. Loose connection in ignition system 6. Loose connection in primary circuit to coil 7. If spark is present at black coil cable, trouble is in ignition system | <ol style="list-style-type: none"> 5. Check for loose connections at coil, distributor and spark plugs. 6. Check push-on connector on coil (thin black wire). Check push-on connectors behind dashboard. Should the engine not start, ask for assistance. 7. Check in this sequence: <ol style="list-style-type: none"> A. Turn ignition off. Remove distributor cap and rotor. Clean distributor contacts with stiff paper (post card). Have someone turn engine over with starter. Sparks should be visible between contacts. <ul style="list-style-type: none"> If no spark, check contact of cable connectors between coil and distributor cap. Check if contacts open. If there is still no spark, see your nearest Authorized VW Dealer. B. If sparks are visible between contacts disconnect high tension cable from center connection of distributor cap. With starter cranking the engine point cable to a metal object in the engine leaving a gap of approximately $\frac{1}{8}$". Strong arcing sparks should appear. If there are no sparks, contact your nearest Authorized VW Dealer. |

| Problem | Probable Cause | What To Do |
|---|---|--|
| VW will not start; engine turns over | <p>8. If spark is fairly good at plugs, trouble is most likely in fuel system</p> <p>A. Caused by improper starting procedure. If the gas pedal is depressed too often, the accelerator pump in the carburetor injects too much gasoline</p> <p>B. Carburetor may be flooded, float or needle valve may be sticking</p> | <p>C. If sparks appear at high tension cable, the distributor cap should be cleaned inside and out. Reconnect high tension cable. Remove all spark plugs. If plugs are clean and dry, reconnect ignition cables to spark plugs and bring spark plugs into contact with metal (ground). Hold cable with dry piece of cloth to avoid shock. Sparks should appear between spark plug electrodes when the engine is turned over. If not, clean and dry ignition cables and spark plug connectors and check that ignition cables are tight in distributor cap and plug connectors. Ask for assistance if the above steps did not ensure proper ignition.</p> <p>D. Dirty or wet spark plugs should be cleaned and dried. Install new plugs if necessary. Unburned gasoline on plug electrodes indicates excessive fuel supply.</p> <p>8. Check fuel system in the following sequence:</p> <p>A. Depress gas pedal completely and operate starter for a prolonged period. If engine does not start, remove and dry spark plugs, turn over engine with plugs removed for approximately 30 seconds. Reinstall plugs and start engine.</p> <p>B. Tap around outside of carburetor with wooden or plastic tool handle. Wait a few minutes and try starting again as described at 8 A.</p> |
| Engine stalls shortly after starting | <p>9. Poor fuel supply</p> <p>10. Automatic choke does not open, excessive fuel supply</p> | <p>9. See paragraph 12 through 14.</p> <p>10. Check whether choke valve is in vertical position after ignition has been switched on for 2-5 minutes (depending on outside temperatures). Cover for choke unit must be hot. If choke valve is binding in a closed position, open at fast idle cam and if necessary, retain with wire. See your Authorized VW Dealer.</p> |
| Engine stalls while vehicle is driven | <p>11. Defect in ignition system</p> <p>12. Fuel supply is exhausted</p> <p>13. Fuel pump filter may be clogged</p> <p>14. Gasoline may be contaminated by water, dust or dirt</p> | <p>11. See paragraph 5 through 7.</p> <p>12. Check whether any gasoline is left in tank.</p> <p>13. After removing the upper part of the pump, the fuel filter can be taken out for cleaning.</p> <p>14. See your VW dealer for cleaning of all components of the fuel system.</p> |
| Red warning light for oil pressure comes on while you are driving | <p>15. If light goes on, the oil pressure is too low</p> | <p>15. Stop at once and check oil level. Add oil as necessary. If the oil level is sufficient and light goes on during driving, contact the nearest Authorized VW Dealer before driving on.</p> |
| Red warning light for alternator and cooling comes on while you are driving | <p>16. If light goes on, V belt may be broken or alternator does not charge</p> | <p>16. If belt drives alternator without slipping, switch off all unnecessary electrical equipment (radio, etc.). Drive to nearest VW dealer as otherwise the battery will soon run down. If belt is broken, replace it before driving on because engine cooling fan is no longer working.</p> |
| Vehicles with Automatic Stick Shift. Lever cannot be shifted | <p>17. Control valve fuse burned out</p> | <p>17. Replace fuse 11 (see page 41). Check cable connections on control valve located on the left in the engine compartment.</p> |

Owner Relations

There are more than 1500 Authorized Volkswagen Dealers in North and Central America. Their addresses and telephone numbers are listed in a booklet which is available at your VW Dealer.

Any one of these dealers is well equipped to help you with virtually all VW-related matters; and your dealer should be your primary source.

Should there be an occasion where you need further assistance, you may want to contact your area distributor. We show the addresses and telephone numbers of the VW distributors in the U.S. on the next page.

However, remember that ultimately your questions will be resolved in the dealership with dealer personnel and dealer equipment. We therefore suggest you contact your dealer first.

For quick reference, always include chassis number in correspondence.



Addresses of VW Distributors in the US:

| | | | |
|-------------------------|--|---------------------------|-----------------------------------|
| Maine | Volkswagen Northeastern | Connecticut | World-Wide Volkswagen Corporation |
| Massachusetts | Distributor, Inc. | New York | Greenbush Road |
| New Hampshire | 100 Fordham Road | New Jersey | Orangeburg, New York 10962 |
| Rhode Island | Wilmington, Massachusetts 01887 | | (914) 359-5000 |
| Vermont | (617) 658-6700 | Washington, D.C. | Volkswagen South Atlantic |
| Illinois | Volkswagen North Central | Maryland | Distributor, Inc. |
| Iowa | Distributor, Inc. | North Carolina | 9300 George Palmer Highway |
| Minnesota | 3737 Lake Cook Road | Tennessee (East) | Lanham, Maryland 20801 |
| North Dakota | Deerfield, Illinois 60015 | Virginia | (301) 577-2600 |
| South Dakota | (312) 272-5500 | West Virginia | |
| Wisconsin | | Arizona | Volkswagen Pacific, Inc. |
| Kentucky | Midvo, Incorporated | California (South) | 11300 Playa Street |
| Ohio | 5000 Post Road | Nevada (South) | Culver City, California 90230 |
| | Dublin, Ohio 43017 | Hawaii | (213) 870-3381 or (213) 390-6226 |
| | (614) 889-2911 | Alaska | Riviera Motors, Inc. |
| Indiana | Import Motors Ltd., Inc. | Idaho | P.O. Box 220 VW |
| Michigan | P.O. Box 2008 (2660 28th St., S.E.) | Montana | (Five Oak Industrial RTE 1) |
| | Grand Rapids, Michigan 49501 | Oregon | Hillsboro, Oregon 97123 |
| | (616) 949-7788 | Washington | (503) 645-5511 |
| Florida | Volkswagen Southeastern | Arkansas | Volkswagen Mid-America, Inc. |
| Georgia | Distributor, Inc. | Missouri | 8825 Page Boulevard |
| South Carolina | 155 East 21st Street | Kansas | St. Louis, Missouri 63114 |
| | Jacksonville, Florida 32203 | Nebraska | (314) 429-2141 |
| | (904) 355-1684 | Colorado | Volkswagen South Central |
| Delaware | Volkswagen Atlantic, Inc. | New Mexico | Distributor, Inc. |
| Pennsylvania | 1001 South Trooper Road | Oklahoma | P.O. Box 2207 |
| | Valley Forge, Pennsylvania 19481 | Texas | San Antonio, Texas 78296 |
| | (215) 666-7500 | Wyoming | (512) 341-8881 |
| Alabama | International Auto Sales & Service, Inc. | California (North) | Reynold C. Johnson Company |
| Louisiana | 4200 Michoud Boulevard | Nevada (North) | 7100 Johnson Industrial Drive |
| Mississippi | New Orleans, Louisiana 70129 | Utah | Pleasanton, California 94566 |
| Tennessee (West) | (504) 254-1500 | | (415) 828-6700 |

Technical data

Engine

Four cylinder, four stroke, horizontally opposed, in rear.

Air cooling by fan, thermostat-controlled. Pressure oil feed with gear-type pump.

Oil cooler. Mechanical fuel pump.

Downdraft carburetor with automatic choke and accelerator pump.

Air cleaner with load and temperature sensitive intake air pre-heating.

Exhaust emission control system. Activated charcoal filter in the fuel system.

Bore 3.36 in. (85.5 mm)

Stroke 2.72 in. (69 mm)

Displacement 96.6 cu. in. (1584 cc)

Compression ratio 7.3 :1

Maximum output SAE net 46 hp at 4000 rpm.

Maximum torque SAE net 72.0 lb. ft. at 2800 rpm.

Valve clearance with engine cold Intake and exhaust 0.006 in. (0.15 mm)

Fuel rating "Regular" gasoline incl. low-lead or lead-free fuels*.

Oil consumption U.S. - 1.7-3.4 pints per 1000 miles

* The correct fuel octane rating for your VW engine is listed on a sticker on the inside of the fuel tank flap.

Metric - 0.5-1.0 liter per 1000 km

Imp. - 1.4-2.8 pints per 1000 miles

Transmissions

Manual Transmission

Single plate, dry clutch.

Clutch pedal free play: $\frac{3}{8}$ - $\frac{3}{4}$ in. (10-20 mm)

Balk synchronized four-speed gearbox and bevel gear differential in one housing.

Drive shafts with two constant velocity joints per shaft.

Automatic Stick Shift

Hydrodynamic torque converter with three speed synchromesh transmission, combined with final drive in one housing.

Drive shafts with two constant velocity joints per shaft.

Engine with Manual Transmission

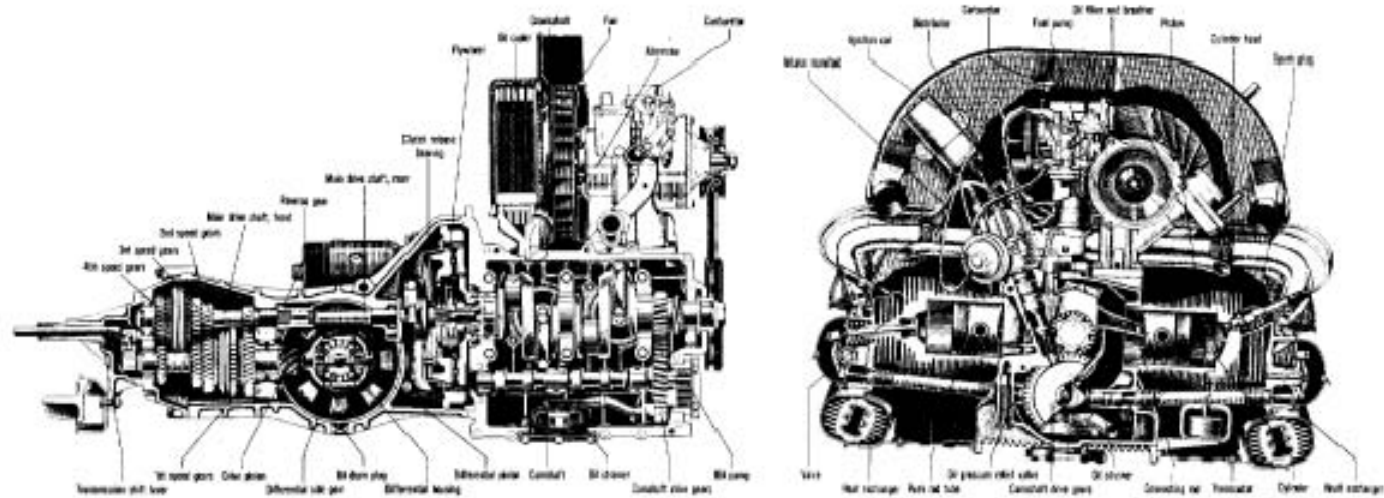

Chassis

Volkswagen Sedan 113 and Convertible

Volkswagen Sedan 111

Platform frame with tunnel-shaped center member, engine/transmission unit bolted to rear frame fork.

Independent wheel suspension: At front with suspension struts incorporating shock absorbers and coil springs, attached to frame head by track control arms and stabilizer. Rear wheel suspension with trailing arms and diagonal links.

Springing: coil springs at front, torsion bar springs at rear, telescopic shock absorbers both front and rear.

Roller steering (energy absorbing) with maintenance free tie-rods and hydraulic steering damper. Hydraulic dual-circuit foot brakes with drums at front and rear, mechanical parking brake effective on rear wheels.

Wheelbase 95.3 in. (2420 mm)

Turning circle diameter 37.5 ft. (9.6 m)

Track at front 54.3 in. (1387 mm)

Track at rear 53.8 in. (1364 mm)

Wheels 4 1/2 J x 15 safety rim wheels

Tires, tubeless Bias Ply Tires

Tire size and pressures Tire size and VW recommended cold tire inflation pressures are listed on a sticker on the inside of the glove compartment door.

Platform frame with tunnel shaped center member, front axle bolted to frame head, engine/transmission unit bolted to rear frame fork.

Independent wheel suspension: torsion arms at front, trailing arms and diagonal links at rear.

Torsion bar springing, telescopic shock absorbers, stabilizer at front.

84.5 in. (2149 mm)

36 ft. (11 m)

52 in. (1322 mm)

53.5 in. (1362 mm)

Electrical system

| | | |
|--------------------------------|---|--|
| Voltage | 12 volts | |
| Battery | 45 Ah | |
| Starter | 0.7 bhp, with Automatic Stick Shift 0.8 bhp. | |
| Alternator | max. 700 watts | |
| V belt size | 9.5 x 900 LA "DA", 9.5 x 905 LA "DA", 9.5 x 905 LA "XDA" ("DA" = low stretch factor) | |
| Ignition distributor | with combined vacuum and centrifugal spark advance | |
| Firing order | 1-4-3-2 | |
| Ignition timing | for correct specifications for your engine, see label in engine compartment | |
| Contact breaker gap | 0.016 in. (0.4 mm) | |
| Spark plugs | Bosch W 145 T 1, Bosch W 175 T 1 * Beru 145/14, Beru 175/14* Champion L 88 A | } or plugs with similar values from other manufacturers |
| Plug thread | 14 mm | |
| Electrode gap | 0.028 in. (0.7 mm) | |

* To be used in vehicles driven at high speed for long periods in areas, where the average temperature is above 77° F.

Dimensions and weights

| | Volkswagen Sedan 113 | Volkswagen Convertible | Volkswagen Sedan 111 |
|---|---------------------------------|-----------------------------------|---------------------------------|
| Length | 163.0 in. (4140 mm) | 163.0 in. (4140 mm) | 159.8 in. (4060 mm) |
| Width | 62.4 in. (1585 mm) | 62.4 in. (1585 mm) | 61.0 in. (1550 mm) |
| Height | 59.1 in. (1500 mm) | 59.1 in. (1500 mm) | 59.1 in. (1500 mm) |
| Ground clearance | 5.9 in. (150 mm) | 5.9 in. (150 mm) | 5.9 in. (150 mm) |
| Unladen weight (ready for use) | 1984 lbs. (900 kg) | 2072 lbs. (940 kg) | 1830 lbs. (830 kg) |
| Vehicle capacity weight ** | 739 lbs. (335 kg) | 739 lbs. (335 kg) | 739 lbs. (335 kg) |
| Gross vehicle weight | 2844 lbs. (1290 kg) | 2844 lbs. (1290 kg) | 2645 lbs. (1200 kg) |
| Gross axle weight, front | 1190 lbs. (540 kg) | 1190 lbs. (540 kg) | 1080 lbs. (490 kg) |
| rear | 1675 lbs. (760 kg) | 1675 lbs. (760 kg) | 1609 lbs. (730 kg) |
| Permissible roof weight*** | 110 lbs. (50 kg) | — | 110 lbs. (50 kg) |
| Permissible trailer weights: | | | |
| Trailer without brakes | 882 lbs. (400 kg) | 882 lbs. (400 kg) | 882 lbs. (400 kg) |
| Trailer with brakes | 1433 lbs. (650 kg) | 1433 lbs. (650 kg) | 1433 lbs. (650 kg) |
| Trailer tongue load | 55-88 lbs. (25-40 kg) | 55-88 lbs. (25-40 kg) | 55-88 lbs. (25-40 kg) |

** Less, if an VW Air Conditioner is installed (see page 29)

*** Applies only to roof rack mounted to rain gutters. Distribute load evenly!

Capacities

Fuel Tank

Volkswagen Sedan 113

and Convertible 11.1 U.S. gal. (42 liters; 9.2 Imp. gal.)

Volkswagen Sedan 111 10.6 U.S. gal. (40 liters; 8.8 Imp. gal.)

Engine 5.3 U.S. pints of engine oil (2.5 liters; 4.4 Imp. pints)

Transmission

and final drive 6.3 U.S. pints of hypoid oil (3 liters; 5.3 Imp. pints),
refill with 5.3 U.S. pints (2.5 liters; 4.4 Imp. pints)

On vehicles with Automatic Stick Shift:

Torque converter circuit approx. 7.6 U.S. pints ATF (3.6 liters; 6.3 Imp. pints)
Does not have to be changed

Transmission

and final drive approx. 6.3 U.S. pints Hypoid oil (3.0 liters; 5.3 Imp. pints)

Brake system approx. 0.53 U.S. pints (0.25 liter; 0.44 Imp. pints)

Oil bath air cleaner approx. 0.9 U.S. pints (0.4 liter; 0.8 Imp. pints)

Windshield washer approx. 3.6 U.S. pints of fluid (1.7 liter; 3 Imp. pints)
operating pressure 42 psi (3 kg/cm²)

Performance

Manual Transmission

Automatic Stick Shift

Maximum and cruising

speed. 81 mph

78 mph

In any authorized VW dealer's service department, you get VW Specialists who know VW's intimately.

A VW Specialist works on VW's. Period.

Every so often he takes time off and gets a refresher course at one of our VW training centers.

So he learns to fix Volkswagens before he starts working on your car. Rather than while he is working on your car.

We think it is better that way.



Authorized VW Dealers use a unique service system specially developed for the VW.

Lots of service stations say they can repair Volkswagens and a lot of them really can. But they cannot offer you VW Diagnosis.

Instead of giving every VW the same basic maintenance, we treat each one as an individual.

And we have already prepared your car for an even more advanced diagnosis system. The socket in the engine compartment is a part of this system.

Specially trained diagnosticians will check your VW directly using special testing equipment; that means your car gets just the maintenance it needs. No more, no less.

And you get a test report so you know the exact condition of your VW.

It tells you a lot about the car you drive.

