

# Type 2



**1979 Volkswagen Owner's Manual**

**Before Driving**

**Operating Controls**

**Climate Controls**

**Do-it-yourself Service**

**Emission Control**

**Technical Data**

**Gas Station Information**

# Contents

Accelerator pedal	30	Defogging and defrosting	36	Headlights	45
Air cleaner	61	Dimensions	85	Headlight dimmer	24
Alternator warning light	21	Do-it-yourself service	40—67	Headlight switch	23
Ashtrays	25	Doors	10,11,62	Heater / Defroster	35
Assist handles and coat hooks	26	EGR light	21	Head restraints	12
Automatic Transmission	30	Electrical system	84	Horn	18
Automatic Transmission fluid	60	Emergency flasher	23	Ignition / steering lock	19
Auxiliary heater	38,39	Emergency starting	32,66	Instrument illumination	23
Back-up lights	46	Emission Control System	75—80	Instrument panel	18
Battery	64—66	Engine compartment	56	Interior lights	25,47
Brake fluid reservoir	63	Engine number	8	Jack	48
Brakes	30	Engine oil, changing / checking	58,59	Key	8
Brake warning light	22,30	Engine oil grades	87	Kickdown	32
Bulb chart	44	Fuel economy	29		
Buzzer	19	Fuel gauge	20		
Capacities	83	Fuel supply	28		
Catalytic converter	21, 27, 28, 76, 77	Fuses and relays	42,43		
Chassis number	8	Gas Station Information	88		
Cleaning your VW	40,41	Gearshift lever	34		
Clutch pedal	34				

Lane changer	24	Rear view mirrors	25	Technical data	81—85
License plate light	46	Rear window defogger	23	Tires	53—55
Lights	23,45—47	Reverse	31,34	Tool kit	48
Lubricants	88	Safe driving hints	6	Towing and trailer hauling	68,69
Lubrication	62	Safety belts	16,17	Transmission oil grades	83
Luggage compartment	26	Seats	12—15	Troubleshooting	70—73
Manual Transmission	34	Selector lever	31	Turn signal/headlight dimmer switch lever	24
Manual Transmission oil	60,88	Side marker lights	23,45,46	Undercoating	79
Note to Owners	2	Sliding door	11	Unleaded fuel	28,81
Oil pressure warning light	20	Sliding roof	38	Vehicle Identification	8
OXS-light	21	Spare wheel	48,53	Ventilation	36
Parking brake	31	Spark plugs	57	Warning lights	20—22
		Specifications	81—85	Weights	85
		Speedometer	22	Wheel changing	48—51
		Speed ranges	5,34	Windows	9
		Starting hints	27	Windshield washer fluid container	63
		Sun roof	38	Windshield wiper/washer lever	24
		Sun visors	25	Winter operation	52

### **NOTE TO OWNERS**

In Canada, this manual is also available in French. To obtain a copy, contact your dealer or write to:

Volkswagen Canada Ltd.  
Customer Assistance / Assistance à la Clientèle  
1920 Eglinton Ave. East  
Scarborough, Ontario M1L 2M2

### **NOTE AUX PROPRIETAIRES**

Au Canada on peut se procurer un exemplaire de ce Manuel en français auprès du concessionnaire ou de:

- Your car may have all or some of the components described in this manual. Therefore you may find explanations of equipment not installed in your car.
- Text, illustrations and specifications in this manual are based on the information available at the time of printing.
- Check with your authorized Volkswagen dealer on available options or accessories.
- It has always been Volkswagen's policy to continuously make technical improvements at any time during the model year.

---

# BEFORE DRIVING

---

## Your new Volkswagen

is the result of many years of technical research and endurance testing. It is a sophisticated product of engineering, a car designed for maximum efficiency and driving pleasure, a car designed with your safety in mind.

## Your Owner's Manual

contains a host of useful information. Read it before you drive your new car. Acquaint yourself with your car's features and know how to operate it more safely. The more you know about your Volkswagen, the more you will enjoy driving it.

FOR YOUR OWN PROTECTION and longer service life of your car, we ask you to heed our instructions and cautions. Ignoring them could result in extensive mechanical failure or even physical injury.

## Your Warranty and Maintenance booklet

explains how you can keep your Volkswagen in top driving condition by having it serviced regularly. Always have the Warranty & Maintenance booklet with you when you take your car to an authorized dealer for service. Your Service Adviser will record each service ... and that's a good record to have.

The **Owner's Manual** and the **Warranty & Maintenance** record should be left in the vehicle when sold, to make all operating, safety and maintenance service information available to the next owner.

## Operating your car outside the U.S.A. or Canada

Government regulations in the United States and Canada require that automobiles meet specific emission regulations and safety standards. Therefore, cars built for the U.S. and Canada differ from vehicles sold in other countries.

If you plan to take your car outside the continental limits of the United States or Canada, there is the possibility that

- **gasoline may have a considerably lower octane rating. Excessive engine "knock" and serious engine damage could result;**
- **service may be inadequate due to lack of proper service facilities, tools or testing equipment;**
- **replacement parts may not be readily available.**
- **unleaded fuels for cars with catalytic converter may not be available**

**Volkswagen cannot be responsible for the mechanical damage that could result because of inadequate fuel, service or parts availability.**

Certain Volkswagen models are available for delivery in Europe under our tourist delivery and return shipment program.

For details consult an authorized dealer or write to:

in U.S.A.  
Volkswagen of America, Inc.  
Tourist Delivery  
818 Sylvan Avenue  
Englewood Cliffs, N.J. 07632

in Canada  
Volkswagen Canada Ltd.  
Tourist Delivery  
1920 Eglinton Avenue East  
Scarborough, Ontario M1L 2M2

If you bought your car abroad and want to bring it back home, be sure to find out about shipping and forwarding requirements, as well as current import and customs regulations.

## Speed ranges

You can drive your Volkswagen at full speed from the first day. There is no break-in schedule.

There are, however, certain recommended speed ranges for the various gears:

### Manual Transmission

1st gear	up to 15 mph or 24 km/h
2nd gear	between 10 and 32 mph or 16 and 51 km/h
3rd gear	between 15 and 52 mph or 24 and 84 km/h
4th gear	between 30 mph and legal speed limits or 48 km/h and legal speed limits

If you have a traffic situation where it is necessary to accelerate in 2nd and 3rd gear above the recommended speed ranges, you may do so for a brief period only. A governor is installed on the engine to prevent damage from excessive engine speed (revolutions per minute).

### Automatic Transmission

Driving ranges	
D	up to legal speed limits
2	55 mph or 88 km/h
1	25 mph or 40 km/h

**Please observe all local and national speed limits!**

# OPERATE YOUR CAR SAFELY

A lot has gone into the manufacture of your Volkswagen. Including advanced engineering techniques, rigid quality control and demanding inspections. These engineering and safety features will be enhanced by **you, the safe driver,**

- who knows the car and all controls
- who maintains the car properly
- who uses driving skills wisely.

## Before going on a trip . . .

- 1—Be sure tires are inflated correctly. Look for bruises and tire wear.
- 2—See that wheel bolts or nuts are not loose or missing.
- 3—Check engine oil level, add if necessary. Make it a habit to have engine oil checked with every second fuel filling.
- 4—Be sure you have a well charged battery. Each cell should be filled to level with distilled water.
- 5—Check brake fluid level. If too low, have brake system checked.
- 6—Replenish windshield washer fluid.
- 7—Replace worn or cracked wiper blades.
- 8—See that all windows are clear and unobstructed.
- 9—Check whether headlight and tail light lenses are clean.
- 10—Check under car for leaks.
- 11—Be sure all lights are working and headlights are aimed correctly.

You'll find helpful hints on how to perform most of these checks in this manual. If in doubt, have these checks performed by your dealer or any other qualified mechanic.



## **In the driver's seat...**

- 1—Depress plate in center of steering wheel to check whether horn is working.
- 2—Position seat for easy reach of controls.
- 3—Adjust inside and outside rear view mirrors.
- 4—Use safety belts.
- 5—Check operation of foot and parking brakes.
- 6—Check all warning and indicator lights when starting the engine.
- 7—DO NOT leave car idling unattended.
- 8—Lock doors from inside, especially with children in the car.

## **On the highway...**

- 1—Always drive defensively. Expect the unexpected.
- 2—Use signals to indicate turns and lane changes.
- 3—Turn on headlights at dusk.
- 4—Always keep a safe distance from the car in front of you, depending on traffic, road and weather conditions.
- 5—Reduce speed during night hours in-clement weather.
- 6—Observe speed limits and obey highway signs.
- 7—When tired, get off the highway, stop and take a rest. Turn the engine off. DO NOT sit in the car with engine idling. See warning on Engine Exhaust.
- 8—When stopped or parked, always set parking brake.

- 9—When stalled or stopped for repairs, move the car well off the road. Set the emergency flasher and use road flares or other warning devices to warn other motorists.

Have the engine oil level and the ATF (in cars with automatic transmission) checked regularly, even in between the recommended maintenance intervals.

## Vehicle Identification

MANUFACTURED BY VOLKSWAGENWERK AG WEST GERMANY	(month/year)
* INCOMPLETE VEHICLE MANUFACTURED	(month/year)
GWWR LB ( ) ( ) GAWR LB FRONT ( ) (REAR) ( )	
THIS VEHICLE CONFORMS TO ALL APPLICABLE FEDERAL MOTOR VEHICLE SAFETY STANDARDS IN EFFECT	
	(chassis number)
IN (month/year)	TYPE MULTIPURPOSE PASSENGER VEHICLE

B22 513

### Safety Compliance Sticker

This sticker is your assurance that your new Volkswagen complies with all applicable Federal Motor Vehicle Safety Standards which were in effect at the time the vehicle was manufactured. You can find this sticker on the left doorjamb.

The sticker also shows the manufacturer's name, the month and year of production and the chassis number of your car (perforation) as well as the **Gross Vehicle Weight Rating** and the **Gross Axle Weight Rating**.

	MANUFACTURED BY VOLKSWAGENWERK AG WEST GERMANY	(month/year)
	* INCOMPLETE VEHICLE MANUFACTURED	(month/year)
	GWWR kg ( ) ( ) GAWR kg FRONT ( ) (REAR) ( )	
THIS VEHICLE CONFORMS TO ALL APPLICABLE FEDERAL MOTOR VEHICLE SAFETY STANDARDS IN EFFECT		(chassis number)
IN (month/year)	TYPE MULTIPURPOSE PASSENGER VEHICLE	

B23 164

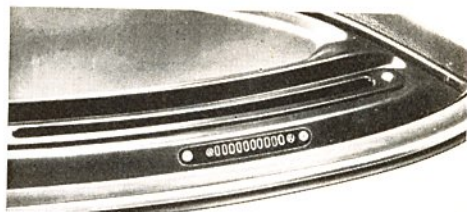

### The Chassis Number

is located on the instrument panel on the driver's side so that it is visible from the outside through the windshield.

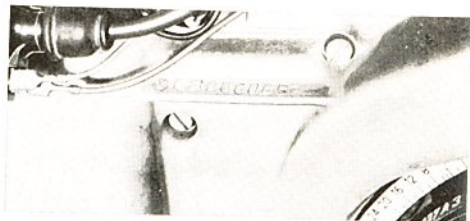

### The Engine Number

is stamped on the crankcase below the breather (not visible).  
And also near the ignition coil.

\* For Campmobile only. Campmobile equipment is installed subsequently.

# OPERATING CONTROLS

## Key

The same key is used for the ignition/steering lock, the doors and the rear luggage compartment lid. The key number is stamped on the key head.

For your protection against car theft: Record the key number and keep in a safe place, such as your wallet. **NOT IN THE CAR!**

If you should lose a key, provide your authorized VW dealer with the key number to obtain a duplicate key.

**DO NOT remove key from steering lock while you are driving or as the car is rolling to a stop. The steering column is locked when you remove the key, and you will not be able to steer the car.**

## Do not invite car theft

by leaving your car unattended with the key in the ignition lock. Take the key with you and lock the doors.

The **buzzer** will sound when you open the driver's door and the key is still in the ignition lock. This is your reminder to remove the key and lock the doors.

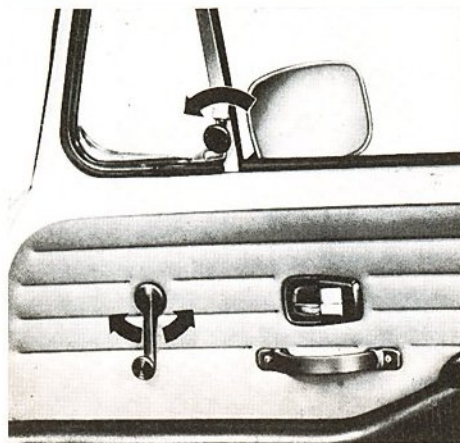

## Windows

**We recommend you do not put decals or other signs on the windows of your car that may interfere with the driver's vision.**

You can lower and raise the windows in the front doors by using the window winders. We cushioned the knobs for your safety.

## Vent windows (where applicable)

To open the vent windows, turn knob in driving direction, move locking lever forward and push out window.

To make closing the vent window easier, we suggest you first push on the forward part of the vent window so that it fits snugly against the weatherstrip. Then grasp the knob, and move the lever back to lock it in place.

## Sliding windows (where applicable)

The passenger compartment is equipped with sliding windows. When closed, windows are locked. To open, press locking knob down and slide window open.

## Doors

**Always drive with locked doors to prevent inadvertent opening of the door from the inside, especially with small children in the car.**

Since your Volkswagen is almost air tight it will be easier to close the door if you open a window slightly.



If the door, with the locking knob depressed, closes by itself, the locking knob will disengage automatically. We provided this additional safety feature so you won't be locked out if the door should slam shut while the key is still inside the car.

### To lock, unlock and open doors from the inside

- Lock or unlock doors by depressing or raising locking knob (3).
- To open doors, pull inside door handle.

### Front doors

#### To lock, unlock and open doors from the outside

- Open doors by squeezing trigger (1) in outer door handle.
- Lock and unlock doors with the key (2).
- Doors can also be locked without a key. First depress locking knob (3), then squeeze trigger (1) in outer door handle as you close the door.

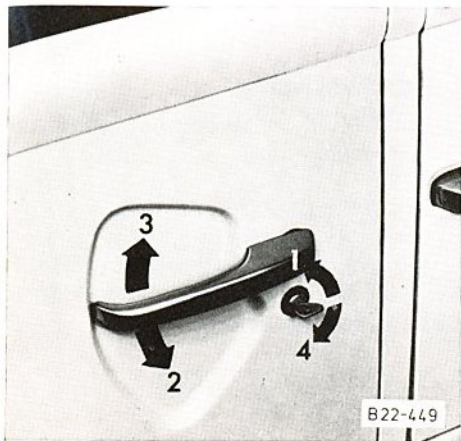

## Sliding door

**Always drive with a locked sliding door.**

### To open from the outside

Unlock the door with the key (1). Then press the handle down (2) and slide the door to the rear. The door is held in the fully open position by a catch.

### To close and lock from the outside

Pull the handle up to release the catch (3). Slide the door forward until it is closed. If the door does not close at the first attempt, **be sure to press the handle down first before closing the door.** Then lock with the key (4).

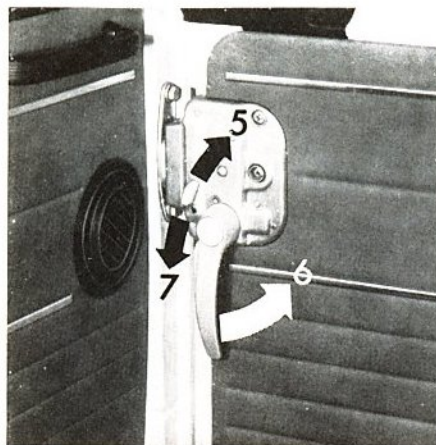

You can only lock and unlock the sliding door from the outside with the key.

### To open from the inside

Move the small sliding knob up (5) and pull the handle back (6).

### To close and lock from the inside

Pull the handle forward to release the catch, close the door and move the small sliding knob down (7).

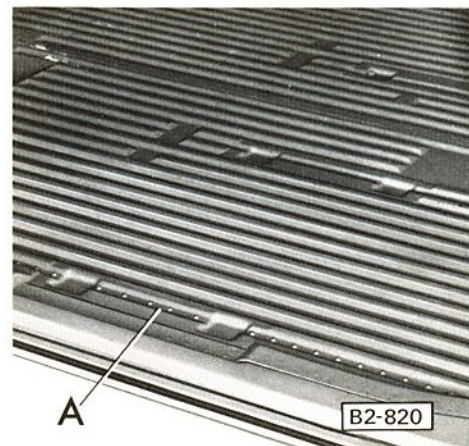

In the VW Kombi and VW Delivery Van, embossed lines – A – on the cargo compartment floor mark the limit up to which cargo can be loaded without obstructing the operation of the sliding door.

## Seats

**We recommend you do not adjust the driver's seat while driving. Your seat may suddenly jerk forward or backward, which could result in loss of control.**

### Head restraint (optional)

A head restraint can be installed for each seat. The head restraints cannot be adjusted.

To remove, pull head restraint out. To install, push head restraint in as far as possible.

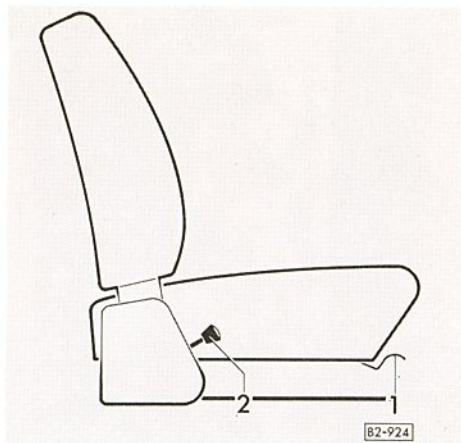

### Driver's seat

(in 7-seater model, also front passenger seat)

#### Seat adjustment (forward or backward)

- Either pull or depress lever (1) in front of seat.
- Slide seat to desired position.
- Let lever go, move seat slightly back and forth to make sure it is securely engaged.

### Seatback adjustment

The backrest is secured and cannot tilt forward accidentally.

To adjust the backrest, push the lever (2) down at the right side of the seat cushion as you exert slight body pressure in the direction desired. Let the lever go to lock the backrest in position.

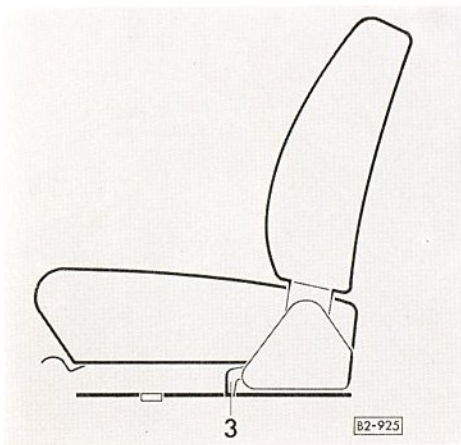

### Installing

- Stand outside vehicle and position seat in front of tracks.
- Hook inboard seat runner on its track first. Then insert outer runner by pulling seat slightly toward you.
- With adjustment lever either raised or depressed, slide seat back on the tracks.
- The hook (3) need not be lifted when putting seat back as the seat can just be pushed past the stop.

### Removing and installing driver's seat

(in 7-seater model, also front passenger seat)

#### Removing

- Stand outside vehicle. Either pull or depress adjustment lever (1) in front of seat. Lift hook (3) against spring – loading, hold it and slide seat past stop.
- Release hook and slide seat forward out of runners.

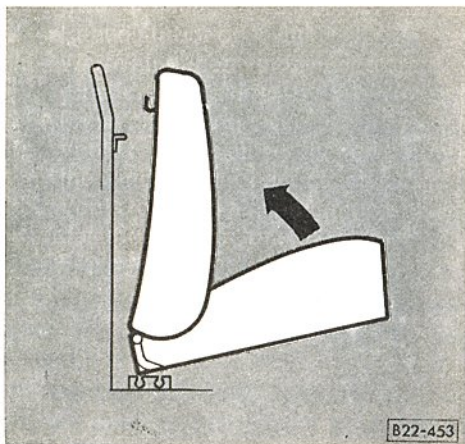

### Front passenger's seat

(9-seater model only)

**The front passenger seat** can be adjusted to two different positions. Lift the seat cushion at the front edge and move the seat into the second notch.

Keep the backrest hooked into the bracket on the partition when adjusting the seat position.

### Removing and installing the front passenger seat

(9-seater model only)

Lift the seat at the front edge first; then remove.

**When putting the seat back in again,** hold the seat with the seat cushion tilted toward the backrest, slide the hook on the rear side of the backrest into the bracket on the partition. Insert the seat cushion in the desired notch, and fold the seat cushion down. Always check to be sure the backrest is securely attached to the partition.

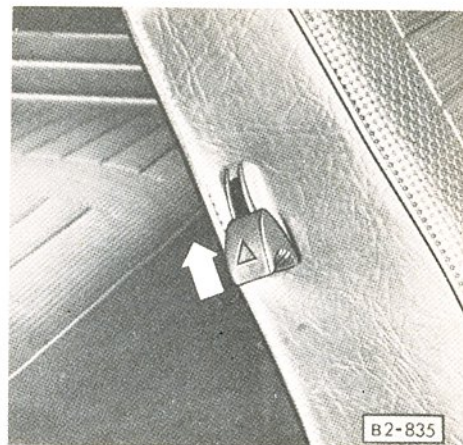

### Passenger compartment

In the 9-seater version (U.S. model only), the backrest of the first seat in the middle row can be tilted forward and out of the way for easy access to the rear bench. To disengage the lock of the backrest, pull up the lever on the side of the backrest.

For your passenger's protection, the backrest lock must be engaged at all times while the car is in motion.



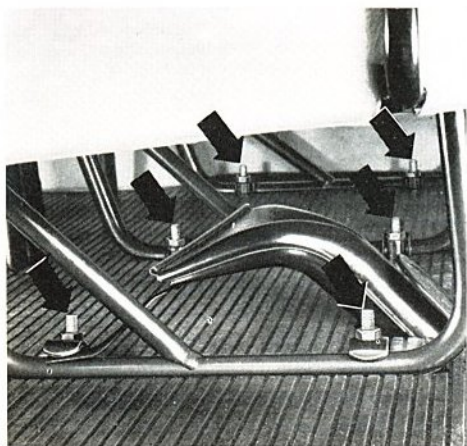

### Removing and installing seats in the rear passenger compartment

All seats in the rear passenger compartment can be taken out. First remove the side and front trimming from the seat frames.

Then unscrew the nuts and take off the mounting supports. Remove seats. Take out bolts by turning them.

When reinstalling the rear seats, be sure to push belt tongue and buckle through between backrest and seat cushion. The safety belts should always be on top of the seat cushions for ready use.

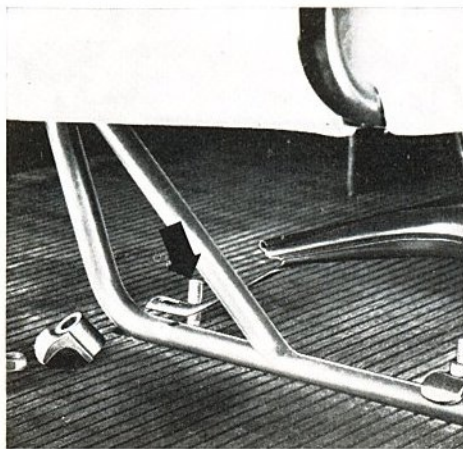

### Center seat bench

After loosening the seat retaining nuts of the center seat bench, remove the heater duct first. A flap will fold to cover the opening in the floor. When reinstalling the center bench, raise the flap and insert the duct in the opening. Be sure the duct ends are positioned underneath the mounting supports before tightening the nuts.

**When reinstalling the seats use all bolts, mounting supports and nuts. Be sure to tighten the nuts firmly.**

## Safety belts

**For you and your passenger's protection, use safety belts at all times while the car is in motion.**

The outer front seats are equipped with combination lap/shoulder belts. For easy storage a hook is provided on the door post.

**In models with a three-passenger front seat, the middle seating position is equipped with a lap belt. See next page on how to use a lap belt.**

**Store the safety belts of unoccupied seats securely. This will reduce the possibility of a belt tongue becoming a striking object in case of a sudden stop.**

### Safety belts for front seats

**A shoulder belt should not be worn by a person less than 4'7" or 1.40 m in height because it would not be in its most protective position, and therefore may increase the possibility of injury in a collision.**

- To **fasten your combination lap/shoulder belt**, grasp the belt tongue, take it off the hook on the door post and pull the belt across your chest and lap.
- Insert the belt into the anchor housing on the inboard side of the seat and push down until it is **securely locked**.
- To **unfasten the belt**, push in the release marked **PRESS** in the anchor housing. The belt tongue will spring out of the anchor housing.

**Belts should not be worn loose or twisted.**

They should fit snugly across your body.

**Do not strap in more than one person in each belt.**

**When not in use the belt should be hung on the hook provided for this purpose on the door post.**



#### Adjusting length

Adjustments can be made before or after buckling up.

To **lengthen** the belt, press in release in buckle as you pull inner loop.

The safety belt is properly adjusted if the **lap portion fits SNUGLY ACROSS THE HIPS** and the **shoulder portion permits you to put your fist between belt and chest.**



To **shorten** the belt pull the free end as illustrated.

**After each adjustment be sure belt is pulled snugly across your lap.**



### Safety belts for rear seats

**The rear seats are equipped** with adjustable lap belts.

Pull the longer section across your lap and insert the tongue in the inboard buckle. Push in until you hear a click to indicate the belt is locked securely.

**The belt should not be worn loose or twisted.**

To **unfasten** the belt, push in the release marked **PRESS** in the buckle.

To **lengthen** or **shorten** the rear seat belt, hold the belt tongue at a right angle to the belt and pull the respective belt section in the desired direction. Take up any slack of the loose belt end by moving the slide on the belt.

**The belts should always be kept on top of the seat for ready use. Do not permit them to get caught under the seat.**

### Belt care

- Belts that have been subjected to excessive stretch forces in an accident should be replaced.
- If belts show damage to webbing, bindings or buckles, they should be replaced.
- If belts do not work properly, see your authorized dealer to have them repaired or replaced.
- Do not modify or disassemble the safety belts in your car.
- Keep belts clean. If they need cleaning, use a mild soap solution, but do not remove belts from car. **DO NOT** use other cleaning agents as they will weaken the webbing.
- **NEVER** bleach or dye safety belts.

# Instrument panel

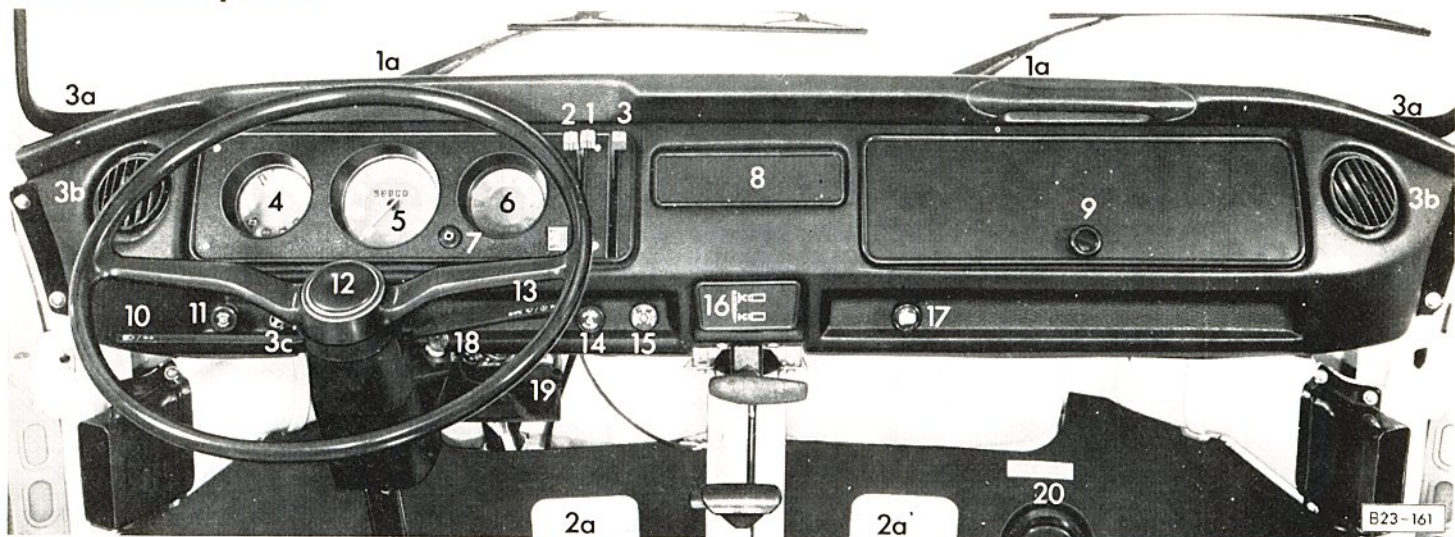

- |   |  |  |
|---|--|--|
| 1 – Heater temperature lever . . . . . 35                                       | 4 – Fuel gauge and warning lights . . . . . 20                             | 13 – Windshield wipers/washer lever . . . . . 24           |
| 1a– Vents for heating and defrosting<br>(two for each side)                     | 5 – Speedometer . . . . . 22   | 14 – Emergency flasher . . . . . 23                        |
| 2 – Heat distribution lever   | 6 – For installation of optional<br>equipment: electric clock . . . . . 22 | 15 – Control knob for Auxiliary Heater 38                  |
| 2a– Warm air outlets for front leg area<br>(one for each side)                  | 7 – Brake warning light . . . . . 22                                       | 16 – Ashtray . . . . . 25                                  |
| 3 – Fresh air control lever   | 8 – Plate over radio aperture  | 17 – Rear window defogger . . . . . 23                     |
| 3a– Vents for fresh air ventilation below<br>the windshield (one for each side) | 9 – Glove compartment  | 18 – Ignition/steering lock . . . . . 19                   |
| 3b– Vents for fresh air ventilation on the<br>dashboard (one for each side)     | 10 – Turn signal/headlight dimmer<br>switch lever . . . . . 24             | 19 – Fuse box . . . . . 42                                 |
| 18 3c– Fresh air fan (not on all models) . . . . . 36                           | 11 – Headlight switch . . . . . 23   | 20 – Container for windshield washer<br>fluid . . . . . 63 |
|   | 12 – Horn button<br>(depress for horn operation)                           |  |

## Ignition/steering lock

The steering is equipped with an anti-theft ignition lock.

### Important reminders before starting

**Never start or let the engine run in an enclosed, unventilated area. Exhaust fumes from the engine contain carbon monoxide, which is a colorless and odorless gas. Carbon monoxide, however, may be fatal if inhaled.**

- **Manual Transmission:**  
Move gearshift lever to Neutral.
- **Automatic Transmission:**  
Move lever to Neutral or Park.

For your protection, fasten safety belts.

**NEVER LEAVE ENGINE IDLING UN-ATTENDED. If warning lights should come on to indicate improper operation, they would go unheeded. This could result in severe damage to the car.**

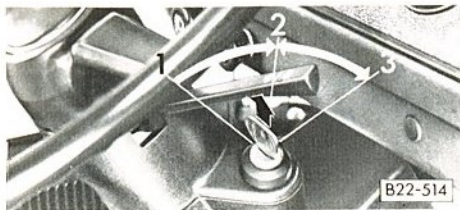

### Switch positions

- 1 – Ignition off/steering locked.  
Insert the key. If it is difficult to turn the key, gently move the steering wheel until the key turns freely.
- 2 – Ignition on/steering free (for towing).
- 3 – Starter engages.

Key returns to Pos. 2 as soon as it is released.

Do not operate starter continuously for more than 10 seconds. If engine fails to start, turn key back to Pos. 1 and restart. Also see “Starting hints.”

### Buzzer

If you leave the key in the ignition/steering lock, the buzzer will sound when the driver's door is opened. This is your reminder to remove the key.

### Remove key and lock steering wheel

- Turn key back to Pos. 1 and pull out.  
Turn steering wheel until it locks.

Only remove key after car has come to a standstill and parking brake is engaged. **NEVER remove key while driving or as car is rolling to a stop. Since steering wheel locks, you could lose control of the car.**

### Warning or indicator lights

The lights for **oil pressure**, **alternator**, **exhaust gas recirculation (EGR - where applicable)**, **oxygen sensor (OXS - where applicable)**, and **brake system** will light up when the ignition is turned on. They should go out after the engine is started.

The **brake warning light** will go out after the parking brake has been fully released.

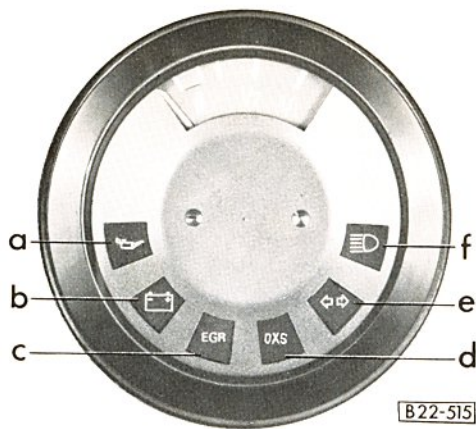

B22-515





## Fuel gauge

The needle in the fuel gauge will indicate the fuel level in the tank within a few seconds after the ignition is switched on.

When the needle is on "R", there is a reserve of about 1 U.S. gal / 4 liters of fuel left in the tank . . . time to refuel at the next gas station.

## Indicator or warning lights

The following indicator or warning lights are in the fuel gauge dial:

a – red		oil pressure
b – red		alternator
c – red	<b>EGR</b>	exhaust gas recirculation
d – red	<b>OXS</b>	oxygen sensor
e – green		turn signals
f – blue		high beam

### a – Oil pressure warning light

lights up when the ignition is turned on. It should go out after the engine is started.

**STOP AT ONCE . . .**

if the oil pressure warning light comes on while you are driving. (Brake warning light also comes on due to design of electrical system. In case of brake failure, **only brake warning** light will come on).

### Turn the engine off!

Check the oil level to make sure you have enough oil. If the cause is somewhere else, do not drive on but contact your nearest VW Dealer.

An occasional flickering of the oil pressure warning light when the engine is idling after a long high-speed trip is no cause for concern if the light goes out upon acceleration.

**Whenever stalled or stopped for repair, move the car well off the road. Turn on the emergency flasher and mark the car with road flares or other warning devices. Before working on any part in the engine compartment, turn the engine off and wait until it has sufficiently cooled down.**

**b – Alternator warning light**



lights up when the ignition is turned on. It should go out after the engine is started.

If this light comes on when you are driving, the alternator may have stopped charging or a fuse in the fuse box may be blown. (See Troubleshooting, items 14 and 15).

**c – Exhaust gas recirculation light EGR**

(Service reminder — not connected in Canada and California models)

The EGR indicator lamp will light up every 15,000 miles or 24,000 kilometers. This is your reminder to take your car to your authorized dealer for the scheduled emission control and maintenance services.

**d — Oxygen sensor light OXS**

(Service reminder — connected in California models only)

The OXS indicator lamp will come on (and stay on) every 30,000 miles or 48,000 kilometers to remind you to take your car to your VW dealer for the scheduled emission control maintenance service.

**e – Turn signals**



For details see “Turn signals”

**f – High beam**



For details see “Headlight dimmer”



B22-499

#### 4 – Fuel gauge and warning lights

(see pages 20 and 21).

#### 5 – Speedometer dial

The speedometer indicates road speed; the odometer records the distances driven. The last digit in red indicates 1/10 of a mile (kilometer in Canada).

6 — This space can be used for installation of **an electric clock**, which is optional equipment. To set the clock, depress the knob in the dial center and turn.

#### 7 – Brake warning light

lights up when the ignition is turned on. It should go out after the engine is started and the parking brake is fully released.

Your Volkswagen is equipped with a power assisted dual circuit brake system. Both circuits, one for the front brakes and one for the rear brakes, can function independently.

If the brake warning light lights up when you apply the brakes while driving, one of the two brake circuits may have failed. First make sure the parking brake is fully released.

**Note: If one brake circuit has failed, the other will still operate, but a longer distance and greater pedal pressure are required to bring the car to a halt. Pull off the road and stop.**

Try out the effectiveness of the brakes by carefully starting and stopping on the road shoulder.

If you judge that the brakes operate safely enough to take you to the nearest dealer, proceed cautiously and at low speed. If you do not feel it is safe to continue, have your car towed to the nearest dealer for repair.

#### Correct functioning of brake warning light

The brake warning light will light up when the ignition is turned on. It will go out after the engine has been started and the parking brake released. This is your assurance that the brake warning light function properly. If the brake warning light does not light up when turning on the ignition, or if it does not go out after starting the engine and releasing the parking brake, there may be a malfunction in the electrical system. If this is the case, contact your VW dealer.



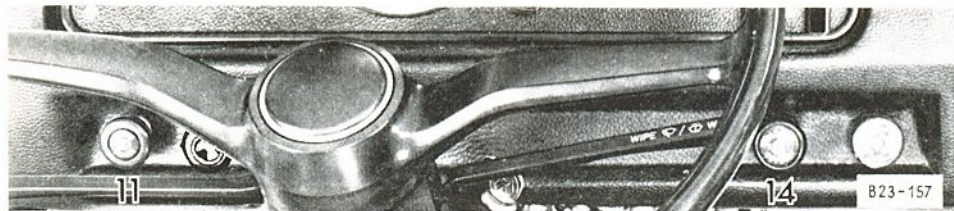

### 11 – Headlight switch



Pull the knob to the first stop to turn on the parking lights, the side marker lights, the license plate, tail and instrument lights, emergency flasher light, and the light in the TEMP switch for the Auxiliary heater.

Pull the knob to the second stop to turn on the headlights (ignition on).

To conserve battery power, the headlights will go out automatically when the ignition is turned off or when the engine is started.

### Instrument illumination

Adjust the brightness of the instrument lights by turning the headlight switch knob.

### 14 – Emergency flasher switch



If your car is disabled or parked under emergency conditions, pull the switch to make all four turn signals flash simultaneously. The warning light in the switch knob flashes, too.

### Move the car well off the road when stalled or stopped for repairs.

When the headlight switch is operated, the emergency flasher knob glows with reduced brightness for easy recognition in the dark. When the emergency flasher is not in operation, the brightness of the light can be regulated together with the instrument panel lights (see instrument illumination). The light has full brightness when the emergency flasher system is in operation.

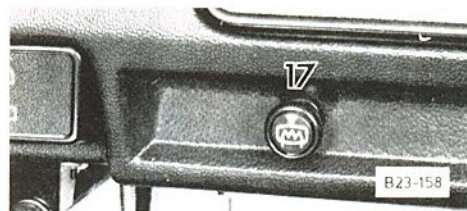

### 17 – Rear window defogger



Turn ignition on first.

Pull out the knob to activate the rear window defogger.

The green control lamp in the knob will light up to remind you that the defogger is switched on.

The rear window defogger will help to keep the inside of the rear window clear of condensation and frost in the winter. Be careful when removing objects from the luggage compartment behind the rear seat. Sharp edges may damage the defogger wires in the rear window.

After the rear window has been cleared, switch the rear window defogger off to avoid an unnecessary drain on the battery.

To give you full battery power while starting the engine, the operating rear window defogger will turn off automatically at this moment.

## Turn signal / headlight dimmer switch lever and windshield wiper/washer lever

There are two levers just behind the steering wheel:

**The lever on the left side** is for the turn signal/headlight dimmer switch.

**The lever on the right side** is for the windshield wiper/washer system.

The turn signals and the windshield wipers only work with the ignition on.

### Turn signals



Lever up	– right turn signal
Lever down	– left turn signal

The green turn signal indicator light in the fuel gauge dial comes on when you operate the lever.

The turn signals are cancelled automatically when you have completed a turn (like driving around a corner), and the steering wheel returns to the straight-ahead position.

### Lane changer

If you are just changing lanes on an expressway, slightly lift or depress the lever. When you release your hold on the lever, it will return to the OFF position.

### Headlight dimmer

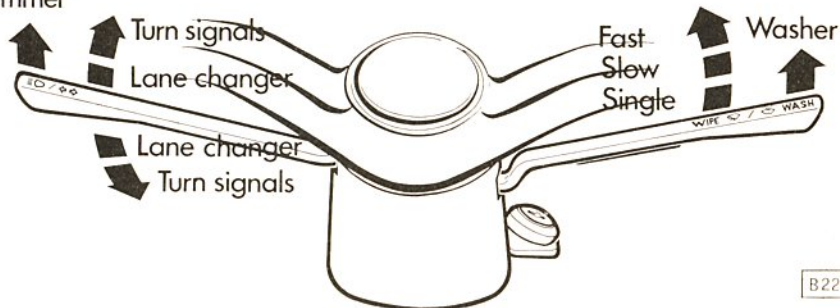

If a turn signal is defective, the control light flashes at about twice the normal frequency. Have your VW dealer check and repair it for you.

### Headlight dimmer



Dim the headlights by pulling the lever toward the steering wheel. The blue indicator light will light up in the fuel gauge dial when the high beams are on.

### Windshield wipers



The windshield wiping system operates at two speeds: low and high.

Lifting lever to first stop	– low speed
Lifting lever to second stop	– high speed

If you just slightly lift the lever before reaching the first stop, the wipers will wipe as long as the lever is held in this position and come to a stop when released.

To give you full battery power while starting the engine, operating windshield wipers will stop automatically at this moment.

### Windshield washer



## WASH

To spray washer fluid on the windshield, pull the lever toward the steering wheel. You can operate the washer from any selected wiping position.

Avoid running the wiper blades over a dry windshield . . . you may scratch the glass. Spray washer fluid on it first.



## Rear view mirrors

Adjust the outside and inside mirrors before driving off. It is important for safe driving that you have good vision to the rear.

## Inside day-night mirror

You can adjust the day-night mirror from clear daylight visibility to non-glare visibility at night by moving the lever upward or downward at the bottom of the mirror.

## Outside mirror

The outside mirror is hinged and folds flat against the car when struck from either direction.



## Interior lights

### Switch positions

#### Front interior light:

Front      -ON- with front doors open  
Center    -OFF  
Rear      -ON- with front doors closed

#### Rear interior light:

Up/front -ON- with sliding door open  
Center -OFF  
Down/rear -ON- with sliding door closed

## Sun visors

To protect the driver from side glare, the sun visor on the driver's side can be moved toward the door window after lifting it out of its center mounting. **The sun visor on the passenger's side cannot be moved toward the side.**

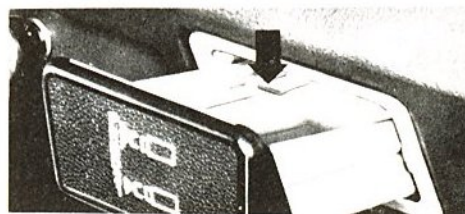

## Ashtrays

You will find one ashtray in the front on the instrument panel and two in the rear passenger compartment.

### Front ashtray

Pull to open. You can remove the ashtray by depressing the leaf spring and pulling the tray out.

To replace, depress the leaf spring, insert the tray in the guide rails and push in with the heel of your hand.

### Ashtrays in the rear passenger compartment

To remove, press down on the tray and pull out. Replace, insert the bottom of the tray first, then push in.

Never use ashtrays as waste paper receptacle . . . fire hazard.

## Coat hooks/Assist handles

For your convenience, there are several coat hooks on the door posts.

Hang clothes in such a way that they do not obstruct the driver's vision.

For easier entrance and exit of passengers, we have provided 5 assist handles:

1 on the dashboard for the front passenger seat, and

4 in the rear passenger compartment.

## Luggage compartment

The rear luggage compartment is easily accessible through the lid at the rear of the vehicle. You lock and unlock it with the key.

To open the lid, depress the lock and raise the lid until it is held in the fully open position by springs. Do not let the lid fly open on its own.

To close the lid, swing it down firmly. Always make sure it is securely closed and locked.

**Do not drive with the rear luggage compartment lid open to prevent exhaust fumes from entering the car.**

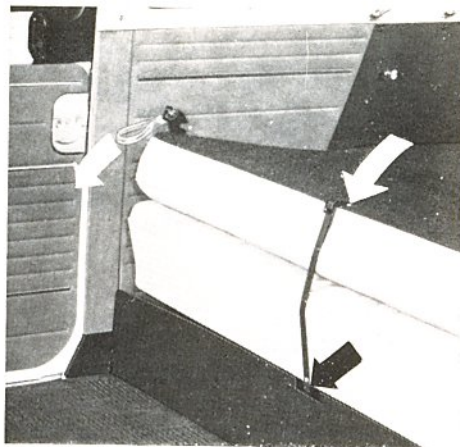

**Do not allow children to kneel or sit on the rear load surface while the car is in motion.**

### Folding backrest for rear seat bench

You can expand the luggage compartment by folding the backrest of the rear seat bench down and fastening the backrest in this position.

If your car is equipped with head restraints, take them off before folding the backrest down.

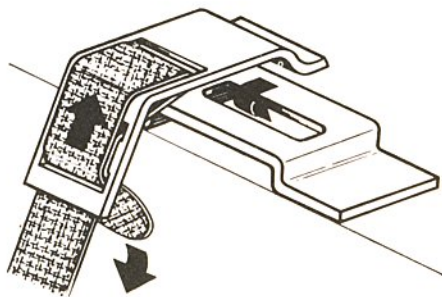

To release the backrest, pull the strap on the right, as seen in driving direction. When you fold the backrest back, it locks automatically in its place.

To hold the backrest in the folded-down position, take the retaining strap from under the seat bench through a cut-out in the kick panel and hook it into the bracket on the back of the backrest.

To adjust the length of the strap, unhook the strap and pull it through the hook in the desired direction.

## Starting hints

**Never start or let the engine run in an enclosed, unventilated area. Exhaust fumes from the engine contain carbon monoxide, which is a colorless and odorless gas. Carbon monoxide can be fatal if inhaled.**

**Fasten safety belts!**

### Automatic Transmission

- Start with selector lever in Neutral or Park.

### Manual Transmission

- Start with gearshift lever in Neutral.

### Starting at all temperatures

It is not necessary to depress the accelerator pedal when starting. This holds true for a cold engine and an engine at operating temperature no matter what the outside temperature is. The fuel injection system, with which your Volkswagen is equipped, automatically supplies the required amount of fuel for Starting.

**Operate the starter for a few seconds only.**

As soon as the engine starts, release the ignition key.

If the engine does not start the first time

or stalls turn the ignition key all the way to the left and restart.

The red warning lights for oil pressure, alternator, EGR or OXS (where applicable), and the brake warning light will light up when the ignition is turned on. They should go out after the engine is started. The **brake warning light** should go out after releasing the parking brake. You need not warm up the engine by letting it idle. Move off and drive at moderate speed until the engine is warm.

### Winter starting of Manual Transmission

On the Manual Transmission, also depress the clutch pedal when starting so that the starter only has to crank the engine.

At very low outside temperatures, switch the warm air blower off before starting engine (move heater lever up).

### Cars with catalytic converter (U.S. models only)

If your Volkswagen is equipped with a catalytic converter as part of the emission control system, the following is important to know:

After the engine is warmed up (not during or shortly after engine start-up) a malfunction in the ignition system, caused by a faulty spark plug, for instance, could reduce the effectiveness of the converter.

To keep the catalytic converter operating properly, we advise you to slow down immediately if you should notice a sudden interruption in the pull of the engine under normal acceleration. This interruption could be for brief moments or of longer duration. Drive slowly (with half or less throttle) to the nearest VW dealer or other qualified workshop to have your ignition system checked and if necessary corrected.

### **NEVER LEAVE ENGINE IDLING UN-ATTENDED.**

**If warning lights should come on to indicate improper operation, they would go unheeded. This could result in severe damage to the car.**

**Do not park or operate the car in areas where the hot exhaust system may come in contact with dry grass, brush, fuel spill or other flammable material.**

## Fuel supply

### UNLEADED FUEL ONLY

for cars with a catalytic converter (U.S. models). Such vehicles are so identified by a sticker on the steering column and another sticker next to the fuel filler cap.

### Cars with catalytic converter

Cars with catalytic converter need unleaded fuel. The catalytic converter is an efficient clean-up" device built into the exhaust system of the car. The catalytic converter burns the undesirable pollutants in the exhaust gas before it is released to the atmosphere.

Deposits from leaded gasolines destroy the catalytic converter and thus defeat its purpose to control harmful exhaust emissions.

Cars with a catalytic converter, requiring unleaded fuel, have a **smaller fuel tank opening,, and gas station pumps have smaller nozzles.** This will prevent accidental pumping of leaded fuel into cars with a catalytic converter.

**Unleaded fuels may not be available outside the continental U.S. and Canada. Therefore, we recommend you do not take your car to areas or countries where unleaded fuel may not be available.**

**REGULAR** low-lead or unleaded fuel, of 91 RON octane rating, for cars without special marking.

Min. octane rating is listed on a plate, visible after taking off the filler cap.

### Regular fuel and octane rating

Octane rating indicates a gasoline's ability to resist detonation. Therefore, buying the correct octane gas is important to prevent engine "knock".

Regular fuels have an octane rating ranging from 91 to 95 **RON** (Research Octane Number) or 87 to 91 **CLC** (U. S. Cost of Living Council Octane rating).

The 91 RON octane rating which you will find on a plate, visible after taking off the filler cap of your car is based on the research method. The CLC octane rating usually displayed on U. S. gasoline pumps is calculated as follows: research octane number plus motor octane number, divided by 2.

That is 
$$\frac{\text{RON} + \text{MON}}{2}$$

The CLC octane rating is usually 4 points less than the RON rating:  
91 RON equals 87 CLC  
95 RON equals 91 CLC

**Fuel filler neck** is located above the right rear wheel.

**Fuel tank capacity** is listed under "Technical Data/Capacities."

**Never start or let the engine run in an enclosed unventilated area. Exhaust fumes from the engine contain carbon monoxide which is a colorless and odorless gas. Carbon monoxide, can be fatal if inhaled.**

**Engine exhaust is dangerous if inhaled. Therefore:**

- **Never start or let the engine run in a closed garage. Open the door.**
- **Exhaust fumes from the engine contain carbon monoxide, which is a colorless and odorless gas. Carbon monoxide can be fatal if inhaled.**
- **Keep the rear lid closed while driving to prevent exhaust gas from being drawn into the car.**
- **If you smell gas fumes in the car, drive with the windows open, but keep the rear lid closed. Have the cause immediately located and corrected.**
- **If you must drive with the rear lid open (e. g. when transporting a large object), open the windows and operate the fan (if installed) to force fresh air inside the car. However, we do not recommend this procedure.**
- **Never carry additional fuel in portable containers in your car. Such containers, full or partially empty, may leak, cause an explosion, or result in fire in case of a collision.**

**How you drive is what you get in fuel mileage**

Fuel economy will vary depending on where, when and how you drive, optional equipment installed in your car, and the condition of your car.

- **Keep a light foot on the gas pedal.**
- **Drive smoothly, avoid abrupt changes in speed as much as possible.**
- **Avoid unnecessary idling. Turn the engine off.**
- **"Warm up" idling wastes gas. Start the car just before you are ready to drive. Accelerate slowly and smoothly.**
- **Do not carry unnecessary weight.**
- **Organize your trips to take in several errands.**

**How to improve fuel mileage**

A well tuned and properly maintained car will help you get maximum fuel economy.

- **Have your car tuned to specifications.**
- **Fuel injection should be adjusted to specifications.**
- **Spark plugs should be clean, properly gapped and firing efficiently.**
- **Air cleaner should be dirtfree to allow proper engine "breathing".**
- **Battery should be fully charged.**
- **Wheels should be aligned.**
- **Tires should be inflated at correct pressures.**

# Controls for Automatic Transmission

## Brake pedal

**Make sure that the movement of the brake pedal is not obstructed by a floor mat, or any other object.**

## Brake system

Your VW is equipped with a hydraulic dual circuit brake system with disc brakes at the front and drum brakes at the rear.

## Brake operation and brake warning light

Make it a habit to check the operation of your brakes before driving off. The brake warning light will light up if one of the brake circuits should fail. The warning light is explained under "**Brake warning light**".

Keep in mind that the braking distance increases very rapidly as the speed increases. At 60 mph or at 100 km/h, for example, it is not twice but four times longer than at 30 mph or at 50 km/h. Tire traction is also less effective when the roads are wet and slippery. Therefore, 30 always maintain a safe distance.

## Moisture on brakes affects braking

**Driving through deep water may reduce tire traction. Moisture on the brakes may also affect braking efficiency. Cautiously apply the brakes for a test. If you notice a lag in the braking action, the brakes may be wet. They will dry after you have applied the brakes a few times, but do it very cautiously.**

## Brake wear

VW automobiles have excellent brakes, but they are still subject to wear . . . depending on how the brakes are used. If you find that the brake pedal travel has increased, have the brakes adjusted; if necessary between the specified maintenance intervals.

## Brake booster

The brake booster assists braking only when the engine is running. When the car is moving while the engine is not running, more force on the brake pedal is required to bring the car to a stop.

## New brake pads or linings

Brake pads or linings may not have the highest possible braking efficiency when new. Therefore allow for longer braking distance during the initial 100 to 150 miles or 150 to 250 kilometers.



## Accelerator pedal

For good fuel economy we recommend smooth and even acceleration. Very fast, racy driving, alternating between full throttle and hard braking, raises the fuel consumption considerably. Also, tires and brake linings wear faster.



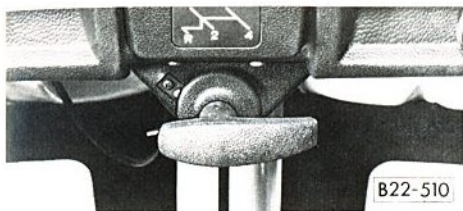

### Parking brake

To set the parking brake, pull out the handle. With the ignition on, the brake warning light will light up. To release the parking brake, first slightly pull the handle as you turn it to the right. Then push it all the way in. When the parking brake is fully released, the brake warning light will go out. Be sure the parking brake is fully released, because a partially engaged parking brake promotes wear of the brake linings.

**Do not remove the key from the steering lock while the car is rolling to a stop. The steering is locked as soon as you remove the key. Take out the key only after the car is parked.**

Always set the parking brake when parking your car. Move the selector lever to position P. (Automatic Transmission). On steep hills also turn the wheels toward the curb.

## Automatic Transmission

The selector lever has 6 positions:

Park  
Reverse  
Neutral  
Drive  
Low  
Low

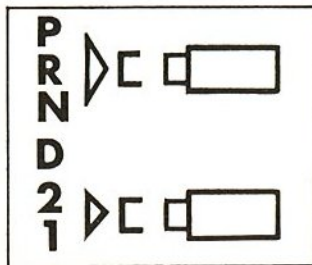

Start in Neutral or Park.

The selector lever has a push button in the handle. The push button must be depressed when selecting the following positions:

From P to R	} depress push button in handle
R to P	
N to R	
2 to 1	

The selector lever can be moved freely between the other positions.

The selector lever console is illuminated when the parking lights or headlights are switched on.

### Driving the Automatic Transmission

There are a few points you should know if you want to take full advantage of your Automatic Transmission.

Remember the following basic rules:

- Apply the parking brake or foot brake before selecting a driving range. When the selector lever is in a driving range, the car may creep even at idling speed. Therefore, do not release the parking brake or foot brake until you are ready to move.
- Do not accelerate while selecting a driving range. At this time the engine must run at idling speed so that no undue stress will be placed on the automatic clutches in the transmission.
- If the selector lever is accidentally moved into Neutral (N) while driving, take your foot off the accelerator pedal and wait until the engine speed has dropped to idling before selecting a driving range.

**Please observe all local and national speed limits!**

## The driving ranges

The Automatic Transmission has 3 forward driving ranges and one reverse. In the driving ranges D and 2, the Automatic Transmission changes gears automatically while driving.

### Range D

is the driving range to be normally used for day-to-day driving and highway driving. It ranges from zero to top speed, and all three gears engage automatically while driving.

### Ranges 2 and 1

are to be used for mountain driving or slow driving, and also when you want to make use of the engine's braking effect.

### Range 2

should only be used up to 55 mph or 88 km/h. In "2", only the first and second gears will engage automatically. Therefore, only shift down into driving range "2" when the car speed is below 50 mph or 80 km/h. It is not necessary to let up on the accelerator.

### Range 1

Range 1 is needed on rare occasions, such as steep mountain driving. The first gear engages immediately upon selecting "1". In "1", the transmission will stay in first gear and not shift into second or third. Therefore, **do not select "1" when driving more than 25 mph or 40 km/h.**

### The reverse driving range

The Reverse driving range should be selected only when the car has come to a full stop and the engine is running at idle speed.

### Starting the engine

is only possible when the selector lever is in Neutral or Park. As long as one of the driving ranges is engaged a safety switch prevents the engine from being started.

### Emergency starting

Your Volkswagen with Automatic Transmission cannot be started by pushing or towing. If engine does not start because of discharged battery, the car can be started with jumper cables. Refer to

"Emergency starting with jumper cables". Should the engine fail to start consult your nearest VW dealer.

### Selecting a driving range while driving

Simply release the accelerator pedal and move the selector lever from the range you are in into the range you want. Then step on the accelerator again.

### Moving off

With the parking brake or foot brake set, shift into the range you wish to use, usually position D. To move off, release the brake and accelerate.

Do not release the brake before you are prepared to move, because power is transmitted to the wheels as soon as a driving range is engaged.

### Stopping

When stopping temporarily, at traffic lights for example, it is not necessary to move the selector lever to Neutral. Simply apply one of the brakes. To start off again, release the brake and accelerate.

## Parking

When parking your car, apply the parking brake first; then move the selector lever to position P. To do this, depress the push button in the handle and push the lever forward to the Park position. The transmission is then mechanically locked.

**Shift out** of the Park position before releasing the parking brake.

When the car is parked on a steep hill, shifting out of Park may be a little harder. This is due to the weight the car exerts on the transmission.

The Park position may only be engaged when the car is stationary.

**Do not remove the key from the Ignition/ steering lock until you have parked the car, because removal of the key locks the steering.**

## Maneuvering

When alternating between forward and reverse drive – for instance, while maneuvering the car into a tight parking space – only shift into Reverse or Drive when

- the car has come to a full stop,
- and the engine is running at idling speed.

## Mountain driving

When driving on long, steep and winding mountain roads select range 2 or 1.

## Accelerator “Kickdown”

If you need quick acceleration to pass moving vehicles or to climb steep grades, make use of the accelerator “kickdown” in your VW with Automatic Transmission. It gives you the possibility to shift into a lower gear without moving the selector lever. The accelerator kickdown can only be applied with the selector lever in the driving ranges D and “2”.

When depressing the accelerator pedal you will find resistance at the full throttle position. By applying greater pressure the pedal can be pushed beyond this

point to the kickdown position. The transmission will now shift automatically into the next lower gear to give you maximum acceleration, and only shift up again after the engine has reached maximum speed in that particular gear.

Please observe the following when applying the accelerator kickdown:

- With the selector lever in D, you can apply the kickdown to make the transmission shift down into second gear when driving below 50 mph or 80 km/h and down to first gear when driving below 25 mph or 40 km/h.
- With the selector lever in “2”, you can apply the kickdown to make the transmission shift down into first gear when driving below 25 mph or 40 km/h.
- As soon as you release the pedal from the kickdown position the next higher gear is automatically engaged.

**Be careful when using the kickdown on icy roads. Rapid acceleration may cause skidding.**

# Controls for Manual Transmission

## Speed ranges

You can drive your Volkswagen at full speed from the first day. There is no break-in schedule.

There are, however, certain recommended speed ranges for the various gears:

1st gear 0–15 mph or 0–24 km/h

2nd gear 10–32 mph or 16–51 km/h

3rd gear 15–52 mph or 24–83 km/h

4th gear from 30 mph or 48 km/h up.

If you have a traffic situation where it is necessary to accelerate in 2nd and 3rd gear above the recommended speed ranges, you may do so for a brief period only. A governor is installed on the engine to prevent damage from excessive engine speed (revolutions per minute).

**Please observe all local and national speed limits!**

## Starting

**Gearshift lever must be in Neutral.**

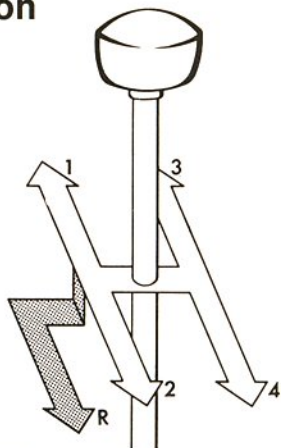

## Reverse

**Only shift into Reverse when the car is not moving.**

To engage Reverse, press lever down, move to left and pull back.

To engage **reverse** gear smoothly, especially after some driving, depress the clutch pedal fully and rest the shift lever in Neutral for a few seconds before shifting into reverse.

Back-up lights go on when you engage reverse gear (with ignition on).

## Gearshift lever

The Manual Transmission is fully synchronized. The four forward gears and

a reverse gear are arranged as illustrated.

**Resting your hand on the shift lever knob while driving will cause premature wear in the transmission.**

## Clutch pedal

Always depress the clutch pedal fully when changing gears. Do not hold the car on a steep hill with the clutch pedal partially depressed. This may cause premature wear or damage.

## Economical driving

If you drive smoothly and in a controlled style you will be rewarded by savings in fuel and general expenses. Very fast, sporty driving with full throttle acceleration and continuous alternating between full throttle and hard braking will raise fuel consumption considerably. Also tires and brake linings wear faster.

You can drive most economically between:

10 and 23 mph or 16 and 37 km/h in 2nd gear

15 and 35 mph or 24 and 56 km/h in 3rd gear

30 and 50 mph or 48 and 80 km/h in 4th gear.

# CLIMATE CONTROLS

## Heater/Defroster

A fresh air heater/defroster is standard equipment on your Volkswagen. The three control levers are located on the instrument panel.

### Heater temperature lever 1

This right red lever controls the temperature level:

- Lever up – heat off
- Lever down – heat on fully

By setting the lever at any intermediate position, you can select the degree of heat that is most comfortable for you.

After a reasonable warm-up time, which also depends on the speed of the car, warm air will enter the vehicle through the two warm air vents – 1a – at the lower edge of the windshield.

Lever 1 also activates an electric fan. The fan increases the flow of warm air when driving at low speeds and also supplies air when the car is standing still (with ignition on).

### Heat distribution lever 2

With the left red lever you can regulate

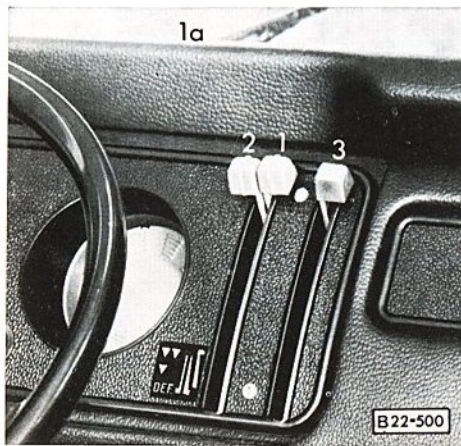

the flow of warm air to the windshield to the front leg area and to the rear passenger compartment.

Lever up ▼▼

front **and** rear footwells fully open

Lever in middle position ▼

only front footwells open

Lever down ▲ DEF

outlets below the windshield open, front and rear footwells closed

You can select any intermediate position to regulate the heat for the front and rear.

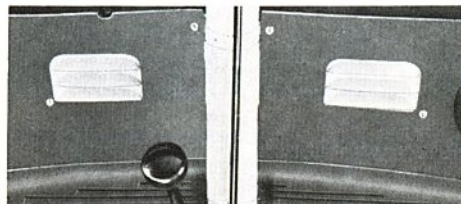

The warm air outlets for the front leg area are underneath the dashboard.

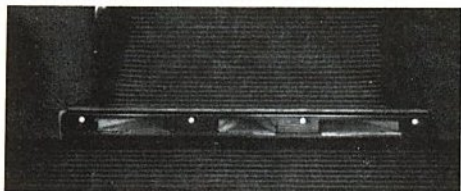

The heat outlets for the center seats in the rear passenger compartment are on the floor in front of the seats; and . . .

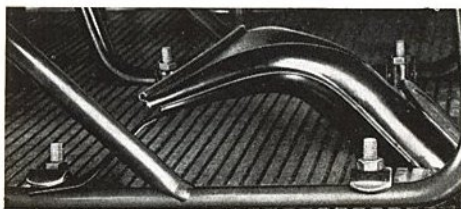

. . . those for the rear seats are underneath the center seats.

### Hints for defogging and defrosting

Defogging and defrosting of your windshield will be more effective if you direct the total air flow toward the front.

Here is what you do:

**Heater temperature lever – 1 – all the way down** – heat fully on.

**Heat distribution lever – 2 – all the way down** – no heat to car interior.

**Close round vents – 3b – on dashboard.**

**Move blue lever – 3 – up** – fresh air ventilation off.

As soon as the windshield is clear the footwell outlets should be opened so that the interior of the vehicle heats up as quickly and evenly as possible.

## Fresh air ventilation

The fresh air circulation system provides a continuous draft-free exchange of air while driving.

With the blue lever – 3 – on the dashboard you can regulate the flow of fresh air.

Lever up – ventilation off  
Lever down – ventilation on

### Fresh air fan – 3 c –

**A two speed electric fan** (not on all models) increases the flow of air when driving at low speeds and also supplies fresh air when the car is standing still (ignition on).

The switch positions are:

0 – off  
I – low speed  
II – high speed

To give you full battery power while starting the engine, the operating fresh air fan will stop automatically at this moment.

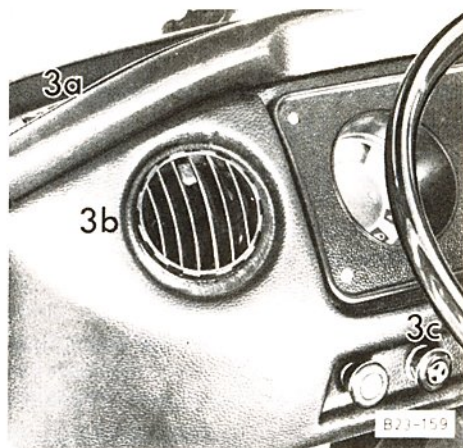

### Fresh air vents on dashboard

Fresh air enters through two vents – **3 a** – below the windshield and two round discharge vents – **3 b** – on the sides of the dashboard. You can regulate the flow of fresh air from the round discharge vents in any direction by turning them.

You can open and close these vents by adjusting the flap in the vents.

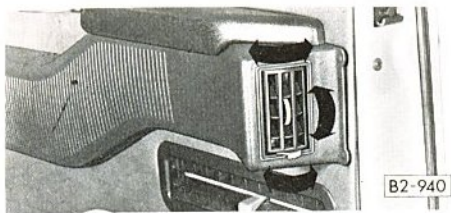

### Fresh air vents for passenger compartment in 7-seater Station Wagon models

Fresh air is supplied to the rear passenger compartment through vents under the front door armrests.

To close vent in left door

- move blue lever to right

To close vent in right door

- move blue lever to left

Fresh air flow can be directed up/down and sideways by adjusting vanes in the vents.

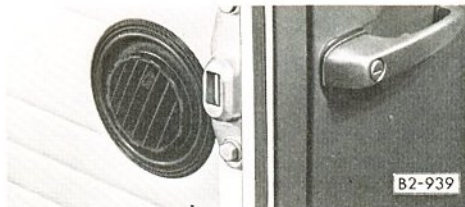

### Fresh air vents for passenger compartment in 9-seater Station Wagon models

Two fresh air vents are on the partition between the drivers cab and the rear passenger compartment. These vents are individually adjustable, and can also be closed.



### Flow – through ventilation

Air that enters the interior of the car via the fresh air circulation system is drawn out through openings in the front door frames.

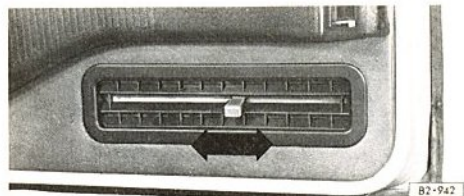

The air flow can be regulated by levers in the inside panel of the front doors (arrows).

- Lever to the front – fresh air circulation on
- Lever to the rear – fresh air circulation off



## Sliding roof (optional equipment)

To open the sliding roof, pull the handle out and turn it counterclockwise; to close the sliding roof, turn the handle clockwise. The sliding roof is locked in any open position.

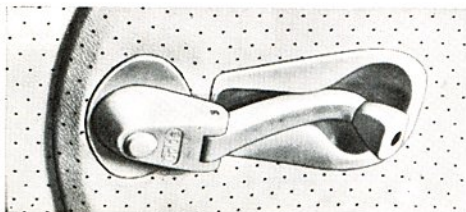

For safety reason, fold the handle back into its recess, as shown in the illustration.

## VW Auxiliary Heater

(optional equipment on U.S. models)

In the auxiliary heating system the engine heat exchangers are combined with a gasoline-operated heater booster, which draws its fuel from the vehicle's fuel tank.

The fresh air is preheated in the engine heat exchangers and then passed on to the heater booster. The thermostatically controlled booster increases the temperature of the preheated fresh air to the desired level.

The heat produced by the heater booster varies according to the temperature in the engine heat exchangers. The heater booster shuts itself off automatically when the engine supplies sufficient heat by itself. When the engine is not running, the heater booster alone heats the car.

Fuel consumption varies according to operating conditions and heat output (approx. 2 US pt or 1 liter per hour).

**The Auxiliary Heater must be turned off when filling the fuel tank.**

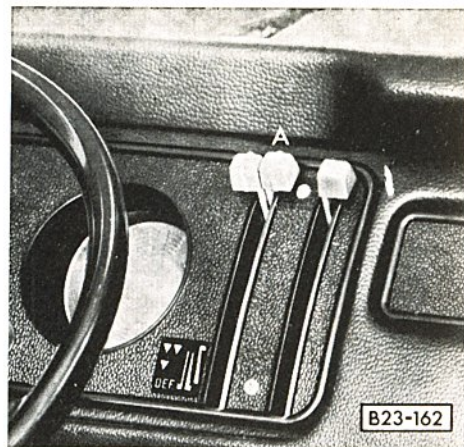

### With ignition on

**To turn heater on** – Move lever A down. Turn temperature switch B (TEMP) to the right to position 1.

The desired temperature can be selected by turning the switch further to the right from low (1) to high (2).

A light in the temperature switch will glow when the headlights are on for easy recognition in the dark.

**To turn heater off** – Turn TEMP switch B to position 0. Move lever A fully up.



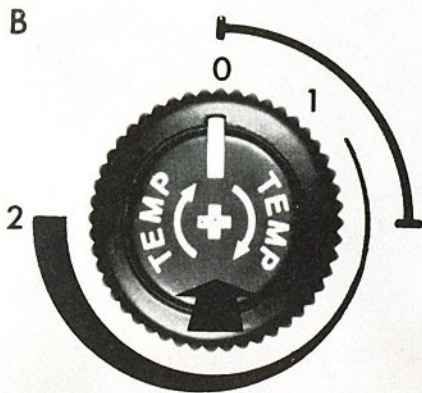

### With ignition off

A timer in the switch gives you the possibility to preheat the vehicle interior for approximately 10 minutes before starting the engine.

To prevent excessive battery drain, we recommend that the heater not be operated several times successively when the engine is not running. This applies particularly when the temperature is low and the full battery capacity is required to start the engine.

**To set the timer,** depress the TEMP switch B and turn right to the first stop.

Release switch. Then select the desired temperature by turning the switch further to the right (range 1–2).

As soon as the timing cycle is completed, the heater will shut itself off. **If you start the engine before the timing cycle is completed, turn the booster heater off before starting the engine.**

If the booster heater is turned off before the timing cycle is completed, the timer will tick until the timing cycle runs out.

**Never start the gasoline heater or let the engine or the heater run in an enclosed, unventilated area. Exhaust fumes from the engine or the gasoline heater contain carbon monoxide, which is colorless and odorless. Carbon monoxide is a very harmful gas and can be fatal if inhaled.**

### Maintenance

During the winter and when driving over very poor roads, mud or snow may tend to accumulate in the exhaust and combustion air intake pipes. Have these pipes checked for blockage from time to time so that the heater can continue to work efficiently.

# DO-IT-YOURSELF SERVICE

## Cleaning your VW

The paint on your VW is very durable, and so is the upholstery. But a car can get a lot of abuse from industrial fumes and corrosive road salt, half-eaten lollipops and muddy dog feet.

A well-cared-for VW can look like new 10 years later. It all depends on the owner and the amount of care he is willing to give to his car.

Here are a few hints on how to keep your VW looking young and beautiful. We have listed some of the car-care products that you may find at your VW dealer.

Whenever using VW-recommended products or other cleaning agents, **follow the directions on the containers. Be aware of warning or caution labels.**

Application	Volkswagen-Product*
Car wash and liquid wax Paint waxing Paint polishing and paint waxing to remove paint oxidation Preservation of chrome parts Paint touch-up Upholstery cleaning, Whitewall tire cleaning Windshield cleaning and washer anti-freeze	Car Wash and Wax Car Wax  Wax Polish combination Chrome Cleaner Touch-Up Paint (all colors) All Purpose Cleaner  Windshield Washer Anti-Freeze & Solvent

**When cleaning upholstery or carpet, never use gasoline, kerosene, naphtha, nail polish remover or any other volatile solvents. They may be toxic or flammable and therefore hazardous. Keep all cleaning agents out of reach of children.**

## Washing your VW

The longer the dirt is left on the paint, the greater the risk of damaging the glossy finish, either by scratching if the dirt is rubbed into the paint, or simply by the chemical effect dirt particles have on the paint surface.

Therefore dirt should be washed off as soon as possible.

**NEVER WASH IN DIRECT SUNLIGHT.** Use plenty of water, a car-wash and wax solution and a soft sponge or hose brush. Begin with spraying water over the dry car to remove all loose dirt before applying the car-wash and wax solution.

Use plenty of water to rinse the car off well. Wipe the car dry with a chamois to avoid water spots.

## Fuses and relays

A failure in the electrical system may be caused by a burned fuse or a defective relay.

The 12-point fuse box with plug-in arrangement for relays is located under the instrument panel on the right hand side of the steering column.

### Replacing a fuse

**Before replacing a fuse, the ground terminal of the battery should be disconnected. If this is not possible, turn off all electrical components and the ignition; remove the key. Replacing a fuse or relay with the engine running or the ignition on could cause electrical shock, burns to hands and fingers.**

- Take cover off.
- Turn all fuses between contact springs until metal fuse strips face upward. In a blown fuse the metal strip is separated.

To replace a fuse, simply depress a contact on either side of the fuse.

- Carefully install new fuse with metal strip facing upward. The fuse must fit tightly between the contact springs — do not bend the springs.

42 ● Reinstall cover.

When a fuse is blown, it is not sufficient to merely replace it. The cause of the short circuit or overload must be found.

On no account should fuses be patched up with tin foil or wire as this may cause serious damage elsewhere in the electrical circuit. It is advisable to always carry a few spare fuses in your car.

### Table of fuses

1— Tail light left, rear side marker light left	7— Accessories
2— Parking lights, rear side marker light right, license plate light, tail light right, front side marker lights	8— Emergency flasher, interior lights
3— Low beam left	9— Accessories
4— Low beam right	10— Windshield wipers, rear window defogger
5— High beam left, high beam indicator light	11— Horn, stop lights, brake warning light
6— High beam right	12— Turn signals, warning lamps for alternator, oil pressure, fuel gauge, back-up lights (Automatic transmission), Auxiliary heater (switch current)

8 amp fuses — white color  
16 amp fuses — red color

Fuses 9 and 10 = 16 amp.;  
all other fuses = 8 amp.

## Additional fuses



The 8 amp. fuse for the **back-up lights** of Manual Transmission is located in the engine compartment on a support on the metal lip in front of wheel housing.

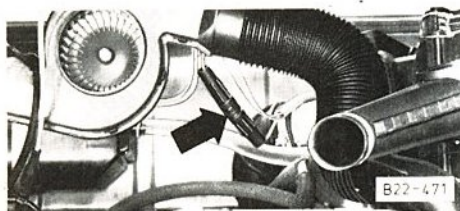

The 16 amp. fuse for the **warm air blower** is located in the engine compartment near the blower motor.

Two fuses for the **auxiliary heater** are located under the instrument panel:

16 amp fuse for main current circuit – near fuse box.

8 amp fuse for heater booster (overheating switch) – in the front leg area behind front trimming on the left side.

Plug connector for **electric fuel pump** is located in engine compartment on left side.

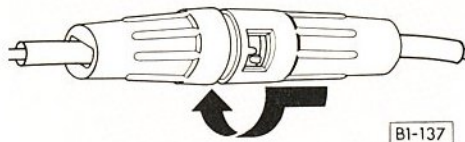

To replace a fuse in an inline fuse holder, pull the holder out of the clip, where necessary. To open the holder, grasp both ends of the holder, press lightly together and twist counterclockwise. Install fuse. To close the holder, put both ends together again, press lightly and twist clockwise.

## Plug-in relays

To preclude any possibility of damage, we recommend you have a defective relay checked and exchanged by your authorized dealer.

## Bulb chart

Always verify part number with your VW dealer

Bulb for	Trade No.	U.S. VW Part No.*	Canada VW Part No.*
Sealed beam headlights	6014	ZVP 118 114	N 17 614 2
Front turn signal/parking lights	1034	ZVP 118 034	N 17 738 2
Front and rear side marker lights	1816	ZAP 118 816	N 17 717 2
Rear turn signal	1073	ZVP 118 073	N 17 732 2
Stop/tail lights	1034	ZVP 118 034	N 17 738 2
Back-up lights	1073	ZVP 118 073	N 17 731 2
License plate light	89	ZVP 118 089	N 17 719 2
Warning and indicator lights for emergency flasher, brake operation, rear window defogger and Auxiliary heater	-	-	N 17 751 2
Selector lever console light (Automatic Transmission)	-	-	N 17 751 2
Interior lights	211	ZVP 118 211	N 17 723 2

# There's nothing but Genuine VW Parts in your new VW.

## That's one reason why it runs like a new VW.

No one knows your new VW in quite the same way as the people who built it. And when it comes to replacement parts, we build them to the same standards and specifications as original equipment. So you can be sure of proper VW fit and customary VW performance every time.

As your VW gets on in years, you may find that some genuine VW replacement parts are different from the original parts. That's because when we improve a part for new VWs, there are times when we make the same improvement available for older VWs.

And the only way you can be sure of getting these improvements is with Genuine VW Parts.

One more thing you get with Genuine VW Parts—even after your new car warranty has run out—is warranty protection on every replacement part. Under our Limited Parts Warranty we will repair or replace every defective Genuine VW Part for 6 months or 6,000 miles, whichever comes first.\*

And to be sure you're getting Genuine VW Parts, look for this symbol on the package. It stands for VW quality.

Shown on the opposite page are just a few of the genuine VW replacement parts available at our Parts Department. We'll be glad to help you select the right ones for your VW.

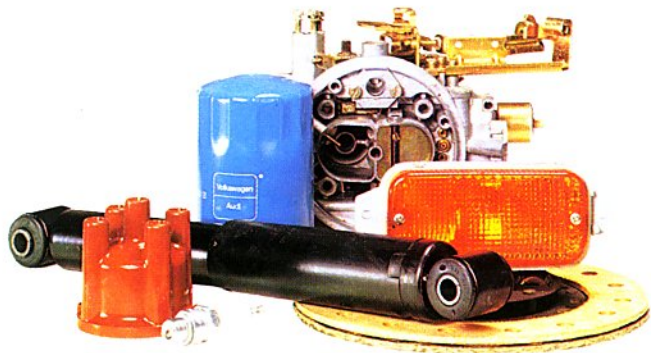

\*See Parts Department for details.

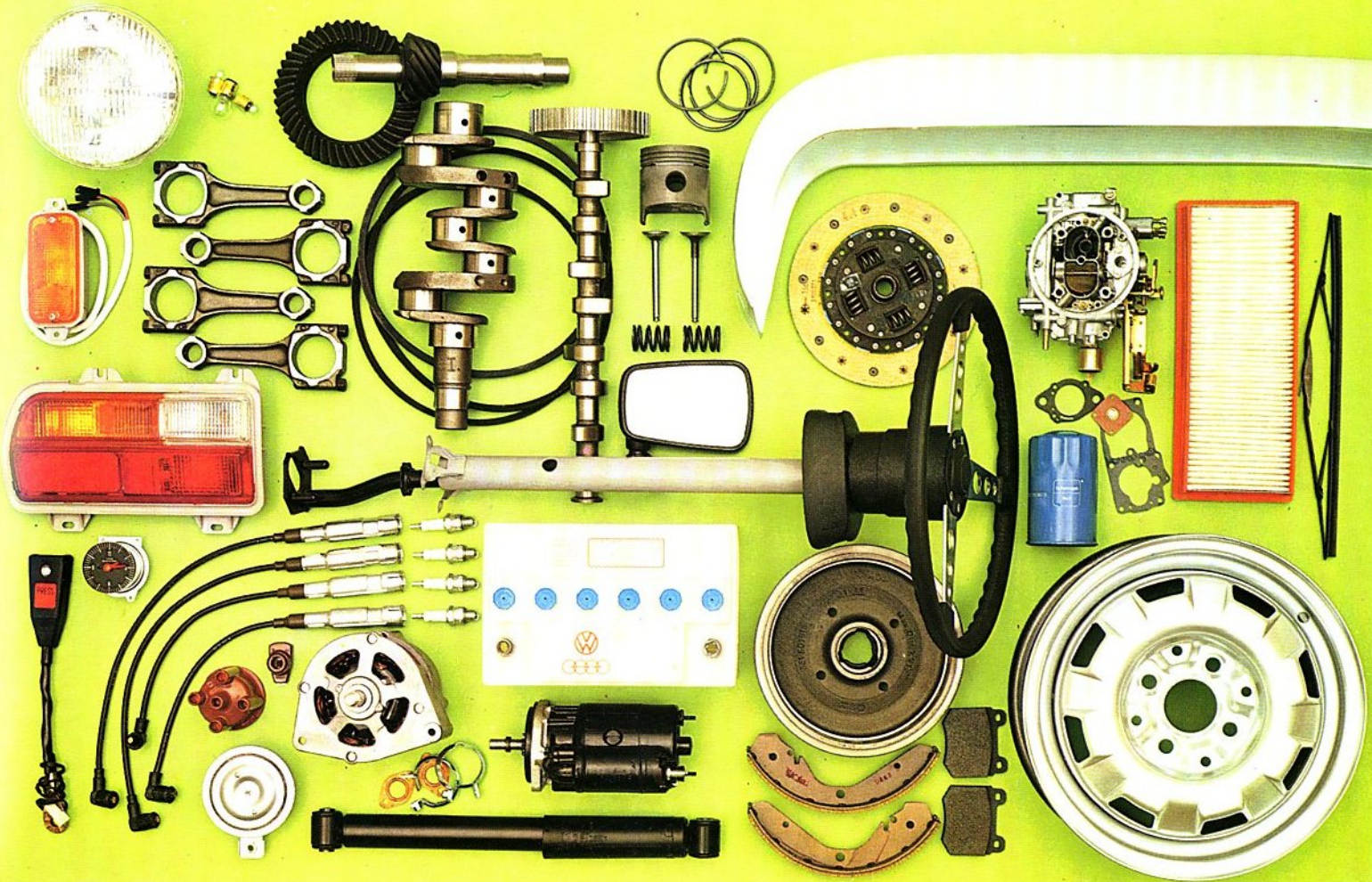

# Autobahn® Accessories.

## The luxurious extras that don't end up looking like add-on extras.

Autobahn Accessories look like they belong in your VW because they match your VW exactly. And fit exactly, too.

You can add versatility to your VW with our permanent luggage carrier that lets you take more gear along. Or our sturdy steel trailer hitch that lets you tow your boat, motorcycle or what have you.

And for your sound choice, there's a wide selection of entertainment components, ranging from basic AM to AM/FM stereo radio with tapeplayer.

For your driving pleasure and driving safety, there are fog lamps, bumperettes, shift knobs, splash guards, ventshades and much more.

Come into our Parts Department for complete information on the selection of Autobahn Accessories available for your VW. We'll be pleased to help you add the luxurious extras that don't look like add-on extras.

# Autobahn®

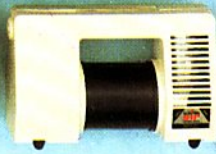



# Replacing bulbs

## Headlights

Your Volkswagen is equipped with double filament seven inch sealed beam units.

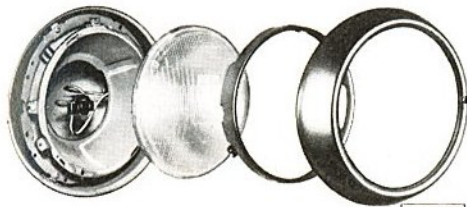

Should it become necessary to replace a sealed beam, loosen the screw of the trim ring. Firmly grasp the loose screw (non-removable) and pull the trim ring off.

- Remove the three short screws in the sealed beam retaining ring and take the ring off.
- Do not alter the position of the long headlight adjustment screws.
- Take the sealed beam unit out of the support ring and pull the cable connector off.

**When installing a new sealed beam unit, be sure the three lugs on the headlight engage properly in the support ring.**

Loosely insert the screw for the trim ring and turn for 2 or 3 turns. Position the upper edge of the trim ring over the lug. Press the ring over the lug and tighten the screw.

If no other headlight part as described here was removed or its position changed, it should not be necessary to aim the headlights. If in doubt have the adjustment checked by your dealer.

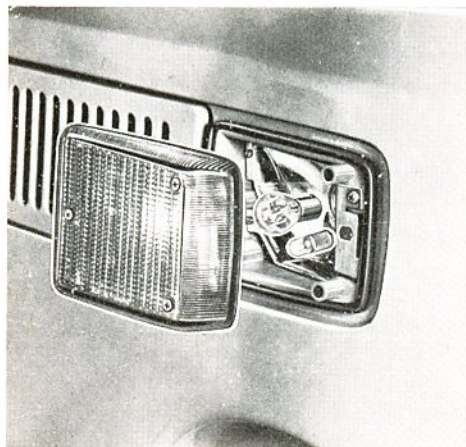

## Front turn signal / parking light bulb and front side marker light bulb

- Remove Phillips screws.
- Take off lens.
- Press bulb lightly into holder, turn it and take it out.
- Install new bulb.
- Be sure gasket is properly positioned.
- Tighten screw evenly. **Do not over-tighten as this may crack the lens.**

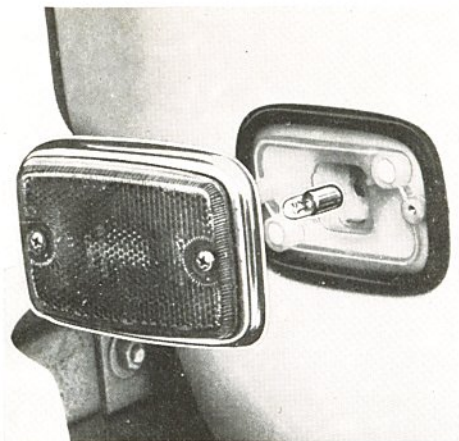

**Rear side marker light bulb**

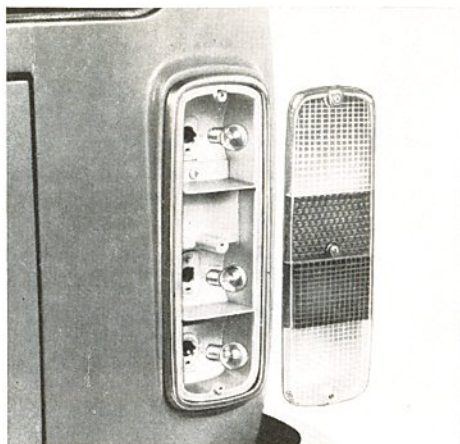

**Rear turn signal / stop / tail light bulb or back-up light bulb**

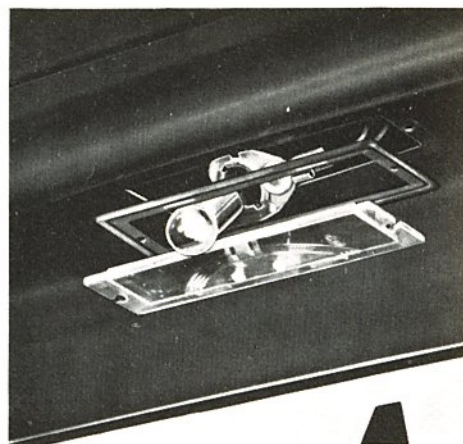

**License plate light bulb**

The following instructions apply to the replacement of the bulbs for the lights shown in the two pictures shown above

**Before replacing one of these bulbs, the ground terminal of the battery should be disconnected.**

- Remove Phillips screws.
- Take off lens.
- Press bulb lightly into holder, turn it and take it out.
- Install new bulb.

Be sure the gasket is properly positioned when reinstalling the lens.

46 Tighten screws evenly. **Do not overtighten as this may crack the lens.**

Open engine compartment lid.

Remove Phillips screws on each side of lens and take off lens with bulb holder. Press bulb in lightly, turn and take out.

- Install new bulb.  
During re-assembly be sure the rubber gasket is properly seated.
- Tighten screws evenly.  
**Do not overtighten as this may crack the lens.**

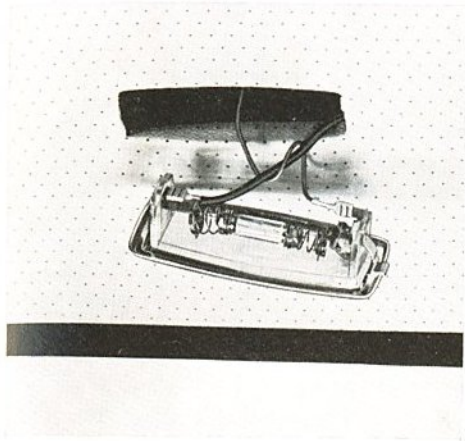

### **Interior light bulb**

- Carefully pry out light housing with a screwdriver.
- Take bulb out.
- Install new bulb.
- Insert housing at rear first, then press in it until retaining spring engages.

## Changing a wheel

If you have a flat tire, **move off the roadway**. Turn on the emergency flasher. In addition, mark the position of your car with flares or other warning devices to alert other motorists.

Before you change a wheel, **be sure the ground is level and firm**. If necessary, use a board.

Set the parking brake and block the wheels opposite the defective wheel on the other side of the car.

**Never jack the car up by the bumper or body.**

1+10

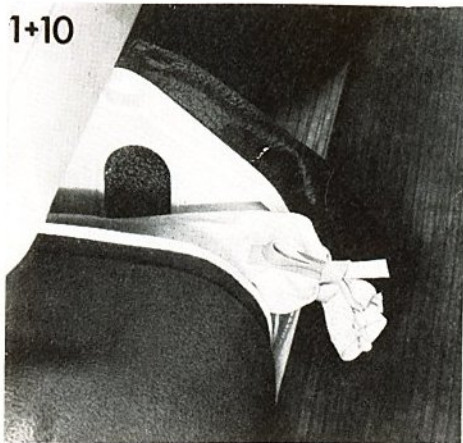

### Step 1

- Take out the bag with tool kit and jack from under the front passenger seat.

2

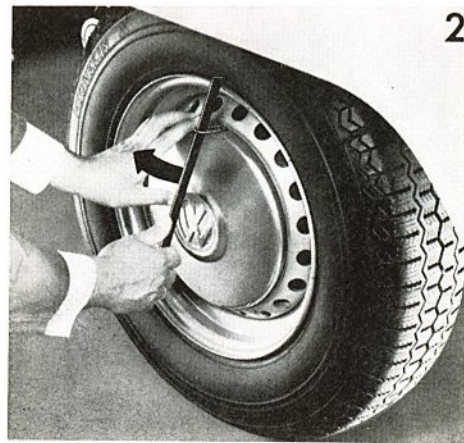

### Step 2

- With the wheels still firmly resting on the ground, remove the hub cap of the defective wheel.
- Insert the puller in the holes at the rim of the hub cap. Put the breaker bar through the puller, brace one end of the bar on the wheel rim and tug lightly on the other end. When you place the hub cap face down, you can use it as a tray for your wheel nuts.

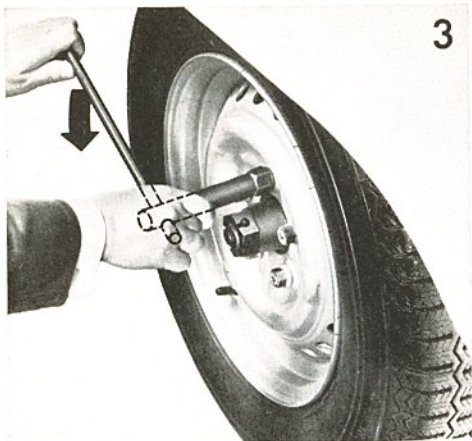

To loosen – turn counter clockwise

To tighten – turn clockwise

### Step 3

- Loosen all wheel nuts counterclockwise about one turn with the socket wrench. Insert the breaker bar to make full use of its leverage. **Do not yet remove the nuts.**



### Step 4

There are two jack ports on each side under the car body for front and rear wheel changing.

Provide a **firm base for the jack on the ground**. If necessary, use a board.

- Securely insert the jack into the jack port closest to the wheel to be changed.
- Before inserting jack, clear jack port.
- Place jack as straight as possible, as shown.

### Step 5

**Never jack the car up by the bumper or body.**

**Do not raise the car until you are sure the jack is securely engaged.**

Passengers should not remain in the car when the car is jacked up.

- **To raise the car**, turn the handle clockwise. Only raise the car as much as is needed to change a wheel.

### Step 6

- Fully unscrew the wheel nuts and place them into the hub cap. Take the nut at the top off last. Place the spare wheel against the wheel hub and slightly rotate the wheel until a bolt hole in the wheel is in line with a threaded stud in the wheel hub. Reinstall the nuts and tighten them crosswise by hand before jacking the car down.



a = to raise    b = to lower

### Step 7

- To lower the vehicle, turn the handle counterclockwise.

### Step 8

- Then go crosswise from one nut to another tightening them firmly with the socket wrench and breaker bar.
- **Correct tightness of the wheel nuts is important.**

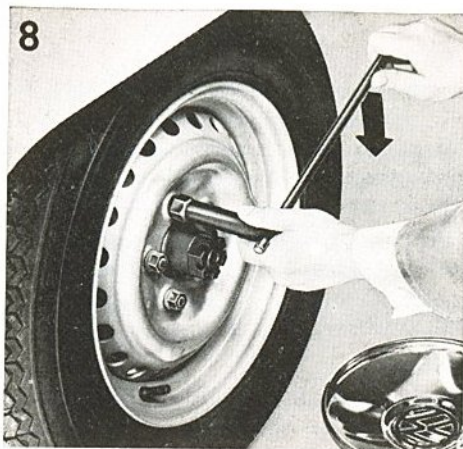

Correctly tightened nuts should have a torque of 94 ft lb / 13 mkg. This torque can be obtained with the socket wrench and breaker bar by any person of average strength. If in doubt about the correct tightness of the wheel nuts, have it checked with a torque wrench by your dealer or at service station.

### Step 9

- To install the hub cap, place it around the lower part of the wheel center. With a firm blow of your hand on the



upper part, the hub cap will snap into place. Make sure it is firmly seated.

### Step 10

- Adjust the air pressure of the tire you have just put on. For correct tire inflation pressures, see the sticker on the left doorjamb.
- Store the jack and tool kit under the front passenger seat.
- Have flat tire repaired at next service stop.

## Winter operation

### Engine oil

will tend to thicken at low outside temperatures which may cause starting difficulties.

**Refer to the viscosity chart under "Lubricants"** to be sure the viscosity of the engine oil in your car still corresponds to the outside temperature recommendation.

**Make it a habit to check the engine oil level with every second fuel filling. Lack of oil may lead to serious damage of the engine.**

Engine oil is necessary to lubricate all moving parts in the engine and also for engine cooling.

If you drive mostly short distances, in city traffic and also in the winter, have your engine oil changed more frequently.

### Door locks

can freeze in the winter if water gets into them. When washing your car in the winter, do not aim the water jet directly at the locks. It is a good idea to put tape 52 over the keyholes to prevent the water

from seeping in. Water in the locks must be removed with compressed air afterwards. Squirt lock de-icer, anti-freeze, or glycerine into the lock cylinders to prevent the locks from freezing.

To open a frozen lock, warm up the key before inserting it. It might also help to warm the lock. Do not use hot water as it will later freeze in the lock.

### Battery

During the winter month, the battery is subjected to greater use than in the summer months. More power is consumed when starting at very low temperatures. Lights and the rear window defogger are used more often. Besides, the battery tends to decrease in capacity as the temperature drops.

Therefore, it is very important to keep your battery in the best possible condition. See also "Battery" on page 64.

**Do not expose battery to open flame or electric spark as hydrogen gas generated by the battery is explosive. Do not let battery acid come in contact with skin, eyes, fabric or painted surface.**

If you mainly drive short distances or in city traffic, have the battery checked and, if necessary charged between regular inspections.

**See "Battery Charging".**

### Windshield wipers

Always loosen frozen wiper blades from windshield. They may tear otherwise.

### Windshield washer

Add anti-freeze to the washer fluid to prevent it from freezing. Follow the instructions on the can for the right amount to be used.

### Spark plugs

Make sure the spark plugs are not worn or have a gap larger than 0.028 in or 0.7 mm. For further details on spark plugs see page 57.

### Emergency equipment

It is good planning to carry emergency equipment in your car. Some of the things you should have are: window scraper, snow brush, container or bag of sand or salt, flares, small shovel, first-aid kit. etc.

# Tires

Your VW is equipped with tubeless radial tires of either designation:

185 R 14 C 6 PR\*  
or 185 SR 14 Reinforced

\* The "C" type tire also bears the label "Load range C."

From the imprint on the tire sidewall, you can determine which type tire is mounted on your vehicle.

The letter "C" stands for "**commercial**", the European rating similar to the domestic "LT", meaning a tire for light trucks. The words "Load Range C" stand for load range C in a **commercial** tire.

The word "Reinforced" refers to a **strengthened passenger car** tire in the European system of tire rating.

The original equipment tires on your vehicle conform to all applicable Federal Motor Vehicle Safety Standards.

## Tire pressures

VW-recommended cold tire inflation pressures are listed on a sticker on the steering column bracket.

### Cold tire inflation pressure means:

when a car has not been driven for at least 3 hours or less than 1 mile.

Always use tire pressure gauge when checking inflation pressures.

### The tire pressures are:

	<sup>3</sup> / <sub>4</sub> load	max. load
<b>185 R 14 C 6 PR</b>		
front	30 psi	30 psi
rear	40 psi	44 psi
<b>185 SR 14 Reinforced</b>		
front	30 psi	30 psi
rear	37 psi	40 psi

For good car handling and long service life, it is important to maintain recommended tire pressures. Tires which are inflated above or below specifications can cause increased tire wear, increased gas consumption and affect the road holding of the car.

In the interest of safety, check the tire pressure of all tires, including the spare tire, at least once a week, and always before going on a long trip.

## Spare tire pressure

The pressure in the spare tire should be:  
44 psi for "C" type tires  
40 psi for "Reinforced" type tires

For road use, adjust the pressure in the tires for their position on the vehicle, front or rear, and also according to vehicle load.



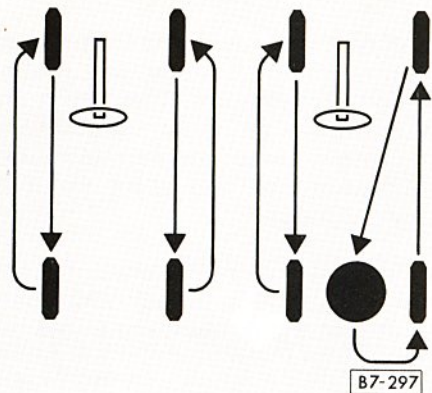

## Tire rotation

Inspect your tires at regular intervals of 2,000 miles or 3,000 kilometers. If you notice unusual or uneven wear, wheels might need alignment or tires should be balanced. Consult your authorized VW dealer.

Tire manufacturers recommend rotation every 7,000 miles or 12,000 kilometers to promote longer tire wear. Wheel rotating and balancing, although an expense to you, will help to increase tire life.

The sketch on the left illustrates how tires can be rotated, depending on whether or not you want to include your spare tire.

After rotation adjust tire pressure and torque wheel nuts diagonally to 94 ft lb / 13 mkg. (Please refer to "Changing a wheel" on pages 49–51).



## Tire wear

The original equipment tires on your VW have built-in tread wear indicators. They are molded into the bottom of the tread grooves and will appear as approximately  $\frac{1}{2}$  in (12.5 mm) bands when the tire

tread depth becomes  $\frac{1}{16}$  of an in (1.6 mm). When the indicators appear in two or more adjacent grooves, it is time to replace the tires. We recommend, however, that you do not let the tires wear down to this extent. Worn tires cannot grip the road surface properly, and are even less effective on wet roads.

**Do not drive with worn tires or tires showing cuts or bruises as they may lead to sudden deflation.**

If you notice that tires are wearing unevenly, consult your Authorized VW Dealer. Uneven wear may not always be due to improper wheel alignment. It can be the result of individual driving habits such as cornering at high speeds.

If the tire pressure is not checked and adjusted regularly, abnormal tire wear can also occur.

## Tire replacement

**Always buy tires of the same specifications.**

Tires of the "C" and "Reinforced" specification may be interchanged, but only in axle pairs, both front and both rear.

For best riding and car handling, replace all four tires at the same time. If this is not possible, replace tires in pairs, either front or rear. If in doubt, check with your VW dealer.

Whenever replacing a tubeless tire, always install a **new** valve stem.

**Do not mix fabric cord and steel cord tires on your vehicle.**

New tires do not possess maximum traction. They tend to be slippery. Break new tires in by driving at moderate speed for the first 100 miles or 160 km.

### Tire care

- Frequently check tires for uneven wear and damage.
- Remove imbedded material.
- Replace worn or damaged tires in time.
- Replace missing valve dust caps.
- Keep oil and gasoline from tires.
- Keep tires inflated correctly.

### Winter tires

Winter tires are not absolutely essential on cars with radial ply tires, because radial ply tires are very good on winter roads.

Better are, however, radial ply M+S tires. For a better grip on snow and ice, you may want to use winter tires with studs, but **check with your local Motor Vehicle Bureau for possible restrictions.**

Cold tire inflation pressures in winter tires should be increased by 3psi, front and rear.

Winter tires should have the same load capacity as original equipment tires and should always be mounted on all four wheels. **Winter tires with studs** should be run at moderate speeds when new in order to give the studs time to settle.

Tires with badly worn treads and studs are very dangerous. Make sure they are replaced in time. Winter tires do not fulfill their purpose if the tread depth is less than  $\frac{5}{32}$ " (4 mm).

For safety reasons, it is not advisable to drive a vehicle mounted with winter tires at top speed. You cannot expect winter tires to have the same degree of traction

on dry, wet or snowfree roads as a normal tire.

Furthermore, winter tires wear rapidly under these conditions, particularly at high speeds.

### Removing and storing winter tires

The driving direction should be clearly marked on all tires before removing them for storage. This is to make sure that they are mounted and run in the same direction as before.

Store tires in a cool and dry place.

### Snow chains

#### Use for front and rear wheels

Check with local authorities for possible restrictions. Only use chains with fine pitch links protruding no more than  $\frac{1}{2}$  in / 15 mm from tire tread and side walls, including tensioner. Wheels must rotate freely in all steering positions with chains mounted at front wheels to prevent damage to body, front axle or brake components. Remove chains when roads are free of snow.

## Exercise extreme caution when working under the engine hood

The engine compartment of any motor vehicle is a potentially hazardous area. If you are not fully familiar with correct repair procedures, do not attempt the adjustments described on the following pages. This caution applies to the entire vehicle.

- **Before working on any part in the engine compartment, turn the engine off and let it cool down sufficiently.**
- **If work has to be done with the engine running, exercise extreme caution to prevent neckties, jewelry or long hair from getting caught in the V-belt.**
- **Always support your car with safety stands if it is necessary to work underneath the car. The jack supplied with the car is not adequate for this purpose.**
- **When working under the car without safety stands but with the wheels on the ground, make sure the car is on level ground, that the**

**wheels are blocked with wedges and that the engine cannot be started. REMOVE THE IGNITION KEY.**

- **Be alert and cautious around engine at all times while the engine is running.**
- **Do not smoke or allow an open flame around gasoline or battery.**
- **Keep a fire extinguisher in close reach.**
- **Incomplete or improper servicing may cause problems in the operation of the car. If in doubt about any servicing, have it done by your VW dealer or any other professionally equipped and qualified workshop.**
- **Improper maintenance during the warranty period may affect your warranty coverage.**

## Engine compartment

You have access to the engine compartment through the rear outside engine compartment lid and through another lid located inside the luggage compartment.

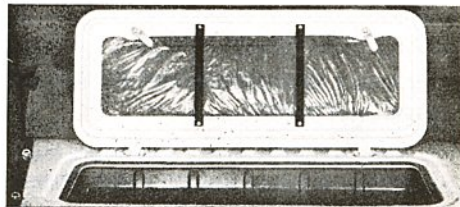

**To open** the lid inside the luggage compartment, roll the floor covering out of the way, then turn the lid handles to the **OPEN** position and lift up the lid.

**To close** the lid, perform the operation in reverse order.

## Cleaning or replacing spark plugs

Turn the engine off!

### Removing spark plugs

Grasp the spark plug connector and pull it off. Do not pull the ignition wires as they may separate from the connectors.

Unscrew the spark plugs with a suitable spark plug wrench.

### Cleaning spark plugs

Dirty spark plugs should be cleaned with a sand blaster, but if not available, the carbon can be removed with a wood or plastic pick. Do not use a wire brush. The plugs should also be clean and dry on the outside to avoid shorting and arcing. **The gap can be set by bending the outside electrode. The gap should be 0.028 in / 0.7 mm.**

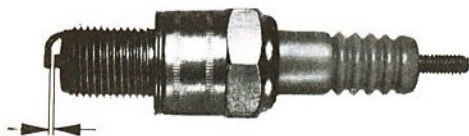

0.028 in / 0.7 mm

Since the spark plug gap tends to increase in time during normal operation, it is advisable to replace spark plugs periodically (see Maintenance Schedule).

### Installing spark plugs

Insert them by hand and screw them into the cylinder head as far as they will go. Only then use the spark plug wrench to tighten them firmly. Do not overtighten.

See **CAUTIONS** on page 56.

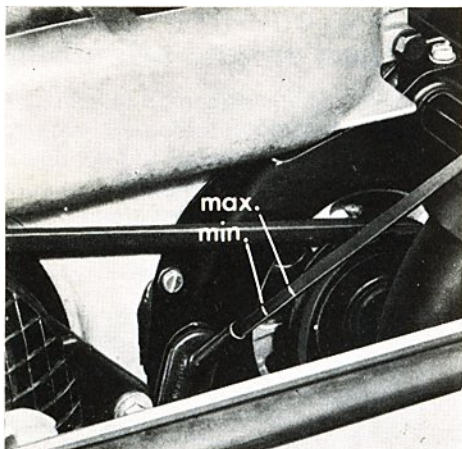

### Checking the engine oil level

- To get a true reading, the car should be on level ground. After turning off the engine, wait a few minutes for the oil to return to the crankcase.
- Pull out dipstick and wipe it clean with a rag.
- Reinsert dipstick; push it in all the way for an accurate reading.
- Pull dipstick out again. The oil level is correct if it is between the "max" and "min" marks on the dipstick.
- If oil level is below "min" mark, or not showing on dipstick, add oil immediately.

The difference between the "min" and "max" marks is about 0,5 U.S. quart or 0,5 liter.

The engine in your car depends on oil to lubricate and cool all of its moving parts. Therefore the engine oil should be checked regularly and kept at the required level. Make it a habit to have the engine oil level checked with every second fuel filling.

### Engine oil consumption

It is normal for your engine to consume oil. The rate of oil consumption depends on the quality and viscosity of oil, the speed at which the engine is operated, the climate, road conditions as well as the amount of dilution and oxidation of the lubricant.

Because of these variables, no standard rate of oil consumption can be established, but drivers should expect an increased oil consumption during the first 1,000 miles or kilometers when the engine is new, and generally at high engine speeds.

Oil consumption can be up to: 2.4 U.S. qt per 1,000 miles or 1,4 liters per 1,000 kilometers.

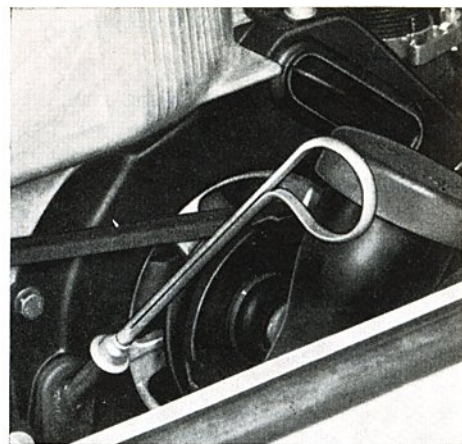

### Adding engine oil

- Unscrew cap from oil filler neck.
- Only add the amount of oil that is needed. Always select a quality oil. The correct oil grade and viscosity recommendation is given under "Lubricants."

**See CAUTIONS on page 56.**

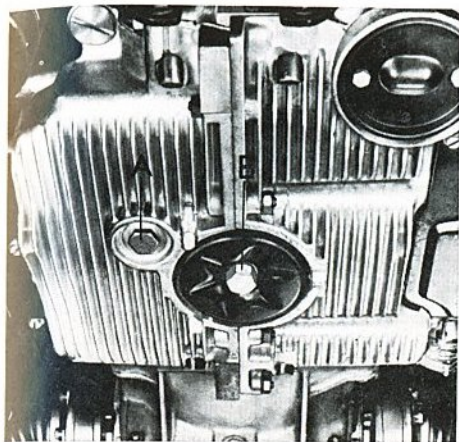

## Changing the engine oil

Change the engine oil at specified mileage intervals, but a least twice a year (see Maintenance Schedule). This is very important as the lubricating properties of oil diminish gradually during normal operation of the car.

We recommend more frequent oil changes if you drive your car only short distances during the winter months.

See **CAUTIONS** on page 56.

- Drain the oil when the engine is still warm. Remove the drain plug — A — first. After the oil is drained, take out the oil strainer by removing the center nut - B - and clean it. The cleaning of the strainer should be done at specified mileage intervals (see Maintenance Schedule). Use new gaskets and washers when reinstalling the strainer to be sure no oil leak will develop later.

### Important

The center nut B for the oil strainer should be tightened with a torque wrench. The correct torque is 7–9 ft lb (1.0–1.3 mkg).

- Fill the engine with oil labeled “For Service API/SE”. For the right oil viscosity, see “Lubricants”.

For engine oil capacity data, see “Capacities”.

**Be mindful of how you dispose of the engine oil. Do not dump it in streams or down sewage drains. Check your local ordinances.**

Because of detergent additives in the oil the fresh oil will look dark after the engine has been running for a short time. This is to be expected, and there is no reason to change the oil more often than recommended by the manufacturer.



## Changing the oil filter

The oil filter should be changed at the intervals listed in your **Maintenance Schedule**

### Schedule

- loosen oil filter element with appropriate wrench and remove
- lightly coat new filter seal with oil
- screw on new filter element until seal just contacts the crankcase
- only hand-tighten according to filter manufacturer's instructions on the carton or on the filter element
- run the engine and check for leaks.

## Manual Transmission oil

Both transmission and final drive are combined in one housing. The lubricant used is hypoid oil which does not have to be changed.

The transmission is checked for leaks during the maintenance service. Should the need arise to replenish the oil filling, it should only be done with the necessary workshop equipment.

## Automatic Transmission Fluid

The torque converter and the transmission are lubricated with Automatic Transmission Fluid (ATF). The final drive requires hypoid oil SAE 90 only.

**Do not tow the car or run the engine, when there is no ATF in the transmission.**

### Checking the ATF level

The ATF has to be checked at frequent intervals, for instance, when the engine oil is being checked, but at least at the specified intervals (see Maintenance

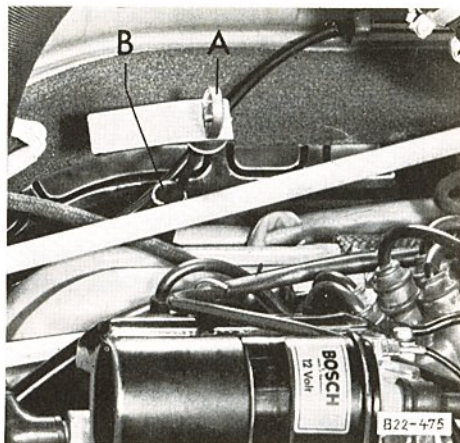

A = dipstick

B = filler neck

Schedule). A correct ATF level is very important for the proper functioning of the transmission.

The reading should be done when the ATF is warm; with the engine idling, the selector lever in Neutral and the parking brake applied.

**See CAUTIONS on page 56.**

The ATF filler neck is in the engine compartment on the left hand side. The dipstick is attached to the plug. Pull it out and wipe it clean first before inserting it to take a reading.

**The Automatic transmission may be damaged by even a tiny speck of dirt. Only use lint free rags to wipe the dipstick. Use a clean funnel or spout when adding ATF.**

You have enough ATF if the fluid level is between the two marks on the dipstick. It should never be above or below these marks.

If level is too high or too low do not just add or drain ATF. Have your dealer check and correct the cause as soon as possible.

For correct ATF specifications, see "Lubricants."

### Changing the ATF

The complete ATF filling has to be changed at recommended mileage intervals. The ATF filling should be changed more frequently under heavy duty conditions such as continued stop-and-go driving, extended mountain driving, and at extremely high outside temperatures (see Maintenance Schedule).

**The transmission oil in the final drive does not have to be changed.**

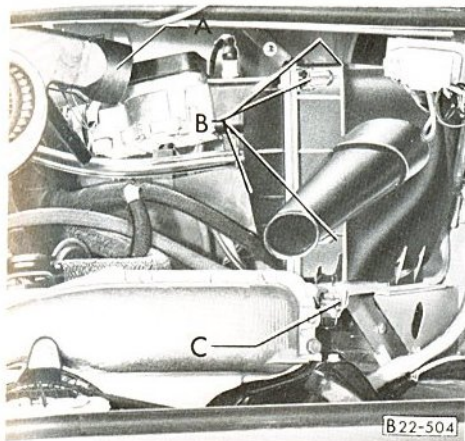

## Air cleaner

All dust present in the air drawn in by the engine is retained by the filter element in the air cleaner.

A dirty air cleaner not only reduces the engine output but can also cause premature engine wear. If local conditions are such that the vehicle is often driven on very dusty roads, the cleaner must be cleaned or replaced frequently.

Under normal conditions it is not necessary to replace the filter element more frequently than is mentioned in the Maintenance Schedule.

See **CAUTIONS** on page 56.

### Checking, cleaning or exchanging filter element

1. Disconnect upper part of hose **A** from heater air blower. Open clamp at lower part of hose **A** and remove hose.
2. Open clamps **B** on air cleaner housing (2 at front and 2 at rear). Open cover on left side to expose filter element.
3. Take filter element out; clean or replace it. Remove dirt by shaking filter element.

#### Note

**The paper filter element must never be cleaned or soaked with gasoline, cleaning fluids or oil.**

**If you want to clean the right section of the air cleaner housing or remove the battery, also disassemble the right section of the air cleaner housing.**

#### Proceed as follows:

4. Open clamp **C**.
5. Lift right section of air cleaner housing up and remove toward rear.

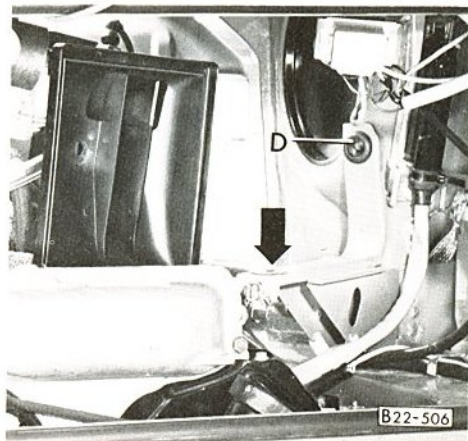

### Reinstalling air cleaner housing

When reinstalling the right section of the air cleaner housing, be sure the rubber grommet **D** is in place.

1. Insert upper projection on housing in **D** first. Then press housing toward rear as you insert lower projection on housing in cutout in bracket base.
2. Close clamp **C**.
3. Reinstall filter element and cover on left side.
4. Close clamps **B**.
5. Reconnect hose **A**.



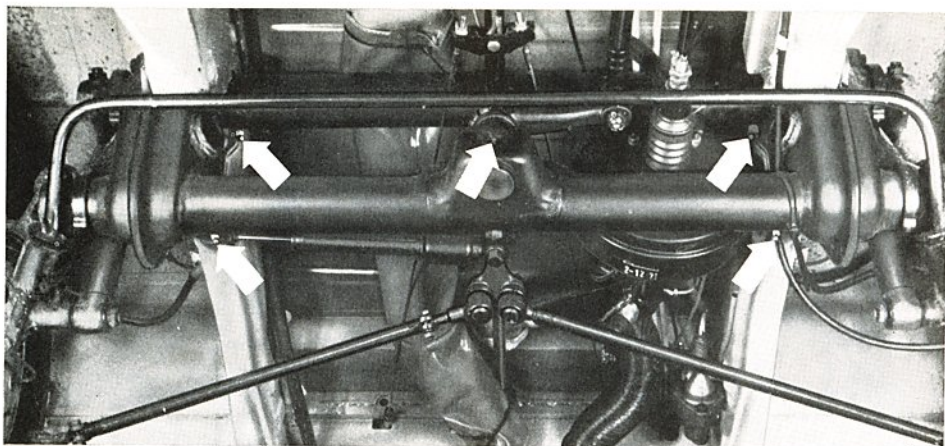

## Lubrication

### Front axle

Lubricate the front axle once a year or at specified mileage intervals (see Maintenance Schedule).

Lift the front end of the car to take the weight off the front wheels. This is necessary to free the bearings to accept the lubricant. There are 5 grease fittings for the front axle. For their location, see arrows in the illustration.

Before forcing grease into the fittings, be sure to wipe them clean with a piece of cloth. Force lithium-based multi-purpose grease into the fittings until fresh grease starts to emerge at the sealing rings.

Wipe off any grease or oil that may have come in contact with tires or brake hoses because grease and oil have an adverse effect on rubber.

See **CAUTIONS** on page 56.

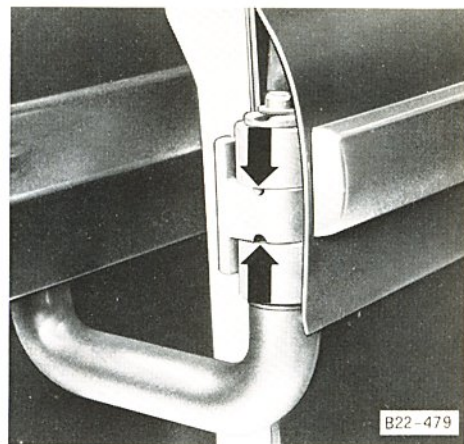

## Door hinges and locks

The hinges of the sliding door and the rear lid should be lubricated with a few drops of SAE 30 engine oil every 6 months. Lubricate where marked by arrows.

Wipe off excess oil with a cloth.

Lubricate the **door lock cylinders** with graphite. Dip the key into graphite and turn it in the lock a few times.



## Brake fluid reservoir

It is located under the driver's seat (lift rubber mat). You can check the brake fluid level through a cut-out in the kick panel.

The brake fluid should always be between the upper and lower edge of the reservoir. If it drops below the lower edge, the cause should be corrected by your Volkswagen Dealer.

Every 2 years, the brake fluid has to be replaced. See Maintenance Schedule.

Only new, unused DOT 3 or DOT 4 brake fluid that meets the SAE recommendation J 1703 and conforms to Motor Vehicle Safety Standard 116 must be used. Do not add or mix DOT 5 silicone type brake fluid with the brake fluid in your car as severe component corrosion may result. Such corrosion could lead to brake system failure.

Luggage may not be stowed under the driver's seat which could damage the brake fluid reservoir.



## Container for windshield washer fluid

It is located on the right under the dashboard.

As clear water is usually not adequate for cleaning the windshield, add a cleaning solution to the water. It is a concentrate, so follow the directions on the can for the correct amount to be used.

You can use windshield washer anti-freeze & solvent all year round. It helps to keep your windshield clean, and prevents freezing of the washer fluid in the winter.

After filling the windshield washer container, screw the cap on tightly.

The capacity of the container is listed under "Capacities".

Pressurize the container up to maximum of 42 psi (3.0 kg/cm<sup>2</sup>) by attaching the hose from the air pump to the container hose.

Place plastic cover over container cap.

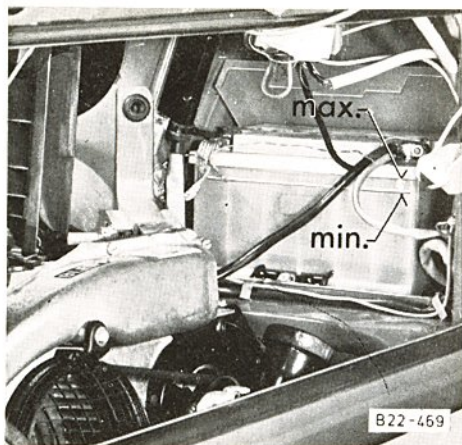

## Battery (12 Volt)

The battery is located in the engine compartment on the right hand side.

The electrical system and the ability of the engine to start readily depends to a great extent on the battery. Therefore, the battery should be checked regularly and kept in good working condition.

## Checking battery fluid level

You can **check** the fluid level through the transparent battery housing. The fluid level should always be between the upper and lower marks on the housing in **each** cell.

If it is below the lower mark, take off the plastic cover, unscrew the filler plug on top of the battery and top the cell up with distilled water. **Only fill up to the upper mark**, otherwise the electrolyte will overflow when the battery is being charged and cause damage.

How often water must be added to the battery depends mainly on operating conditions and on the time of year. As a general rule, the battery electrolyte level must be checked more often in the summer than in the winter, and more often when driving long distances.

**Do not let battery acid come in contact with skin, eyes, fabric, or painted surfaces.**

**If you get electrolyte, which is an acid, in your eyes or on your skin, immediately rinse with cold water for several minutes and call a doctor.**

## Cleaning terminals and connections

The terminals and connections should be kept clean and greased with silicone spray or petroleum jelly. Make sure the ground connection to the body is tight and free of corrosion.

**When working on the battery, be sure not to short circuit the terminals. This would cause the battery to heat up very quickly, which could lead to damage.**

**Never drive the car with a disconnected battery as this may damage the electrical system.**

**Do not expose the battery to an open flame or electric spark. Hydrogen gas generated by the battery is explosive.**

## Charging of Battery

### WARNINGS

- Charge battery in a well ventilated area. Keep away an open flame or electrical spark. Do not smoke. Hydrogen gas generated by the battery is explosive.
- Electrolyte fluid that has squirted out during charging should be washed off with a solution of warm water and baking soda to neutralize the acid.
- If you get electrolyte, which is an acid, in your eyes or on your skin, immediately rinse with cold water for several minutes and call a doctor.
- Never charge a frozen battery. It may explode. Allow a frozen battery to thaw out first.
- Never use a fast charger as a booster to start the engine. This may seriously damage the car's electrical system and the charger.
- Fast charging a battery is dangerous and should only be attempted by a competent mechanic with the proper equipment.

see also CAUTIONS on page 56.

## Slow battery charging

- It is not necessary to take out the battery from the engine compartment, and it is also not necessary to disconnect the cables. Vent caps may be left on, but loosen them to assure proper venting.
- Make sure the electrolyte level in each cell is between the "min" and "max" marks. If necessary top up with distilled water.  
Normally, a battery should be charged at no more than 10 percent of its rated capacity. For example, a charging current of 4.5 Amp. would be used on a battery having 45 Ah. Rated capacity of the battery in your car is listed on the battery housing.

**Heed all warnings and follow instructions that come with your battery charger.**

- 1-Charging rate not over 6 Amp.
- 2-Connect charger cables and switch on charger.  
**Do not connect or disconnect charger cables while charger is operating.**
- 3-After charging, turn off charger and disconnect charger cables.
- 4-Tighten vent caps.

# Emergency starting with jumper cables

## Warnings

- Improper use of a booster battery to start a car represents an explosion hazard.
- Lead acid batteries generate explosive gases. Keep sparks, flame and lighted cigarettes away from batteries.
- If battery is frozen, thaw it out first. Otherwise it may explode.
- Check whether fluid is up to "max" mark. If necessary, top up each cell with distilled water.
- Make sure the voltage of both batteries is the same. You can tell by seeing that each battery has the same number of vent caps. A 12-Volt battery has 6 vent caps.
- Make sure vehicles are not touching.
- Car with discharged battery: turn off lights and accessories. Ignition key should be removed. Move lever to Neutral or Park. Set parking brakes.

- Car with booster battery should be running.
- Remove vent caps from booster battery and discharged battery. Preferably lay a cloth over open vents. This reduces explosion hazard.

To avoid serious injury and damage to car, heed all warnings and instructions.

See CAUTIONS on page 56.

## How to use jumper cables

Improper hook up of booster cables can ruin the alternator. Always connect POSITIVE (+) to POSITIVE (+), and NEGATIVE (-) to NEGATIVE (-).

1. Using red jumper cable, connect one end with clamp to positive (+) terminal (1) of discharged battery.
2. Connect opposite end of cable to positive (+) terminal (2) of booster battery.
3. Using black cable, connect one end with clamp to negative (-) terminal (3) of booster battery.
4. Connect opposite end of cable to a bare metal part bolted directly to the engine block or to the engine block itself of the car with the discharged battery.

5. Start your car in the usual manner.
6. Remove jumper cables from both vehicles in exact reverse order: steps 4 to 1.

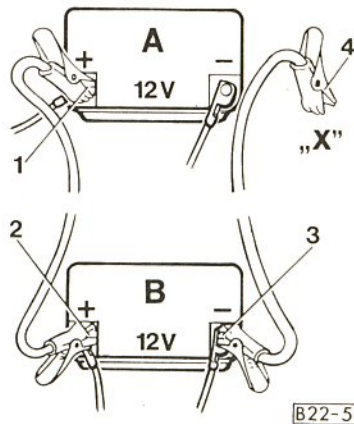

B22-518

A = DISCHARGED BATTERY

B = BOOSTER BATTERY

"X" = TO GROUND ON ENGINE BLOCK

**CAUTION – Cars with Catalytic Converter**

**Do not push or tow this car to start. Damage to the catalytic converter and/or other parts of the car may result.**

## Emergency towing with tow rope

Always observe local laws and municipal ordinances governing towing.

### Towing eyes

Your Volkswagen is equipped with towing eyes at the front and rear. They are for **emergency towing over short distances only.**

- Place gearshift in Neutral.
- Release parking brake.
- Brake booster assist will not be operative when the engine is not running. More brake pedal pressure will be required to bring the car to a stop.
- Turn ignition key slightly to right to unlock steering.
- If necessary, turn on ignition to be able to operate turn signals, parking and stop lights.

**CAUTION — DO NOT leave the ignition on for long periods of time with the engine not running, as damage to the ignition system may result.**

- The driver of the towing car must be very careful when driving off and shifting to avoid sudden and abrupt jerks.
- The driver of the towed car must always keep the tow rope taut.
- **If you are towing another car, it should not be heavier than your VW**

### Caution

**If your VW has an automatic transmission, do not start or tow the car without ATF in the transmission, as this will result in serious damage to transmission and torque converter. This is very important because the transmission will not be adequately lubricated due to the lack of oil pressure normally provided when the engine is running.**

**Your VW with automatic transmission cannot be started by pushing or towing.**

## Emergency towing by commercial tow truck

Your car can be towed by commercial tow trucks using conventional sling-type gear.

**Always tow with rear wheels off the ground**

**If excessive damage or other conditions prevent towing your car with rear wheels off the ground, use wheel dollies.**

**Never allow passengers to ride in a towed vehicle for any reason.**

## Trailer hauling

Your Volkswagen was primarily designed for **passenger transportation**. It is possible, however, to tow a trailer with your car. The manufacturer recommends trailer towing **after** the car's break-in period. **The maximum permissible trailer gross weights and trailer tongue loads are listed under "Permissible Trailer Weights"**.

When towing a trailer, **your safety and satisfaction** depend upon...

...an appropriate trailer hitch (available through VW dealers), or other suitable towing equipment specifically designed for your car.

...installation of adequate trailer brakes, if your trailer will exceed 1000 lbs or 450 kilograms loaded weight. Keep in mind that "loaded weight" includes the trailer's weight **plus** everything you add to it. **Never exceed the specified load capacity of the trailer nor the specified towing capacity of your car.**

...The necessary electrical hook-ups between car and trailer to operate turn signals, stop lights, parking lights and emergency flashers.

...installation of extended outside mirrors on either side to give you a view of vehicles behind the trailer and the actions of your trailer.

...correct and even load distribution. **All** objects inside the trailer should be held securely in place to guard against shifting, be it forward, backward or sideways. **Never carry a passenger in a moving trailer.**

...your own ability and experience to use special driving skills. We recommend you repeat the break-in period detailed on page 5 when you begin your "trailerling". Be constantly alert to the fact that you are operating two units "hitched" together. **You are responsible for the safe movement of both!**

...adequate maintenance of your "rig". Primarily designed for passenger transportation, your car is now performing a service it was not intended for. The additional load will affect durability and economy of performance. More frequent lubrication and maintenance services than normally required will be necessary to keep car and trailer in top notch conditions.

...your own good judgement and knowledge of "trailerage". Be informed about laws and regulations of the interstate Commerce Commission and of the individual states you plan on visiting. Consult your VW dealer and the trailer manufacturer **before you take to the highways.**



## Troubleshooting

Your Volkswagen should repay you with trouble free driving if it receives regular maintenance. Should you ever encounter difficulties in starting your engine or have trouble on the road, there are a few repairs which you can make to get your car going again.

- **Move disabled car well off the road. Turn on emergency flasher lights. If necessary mark vehicle with road flares or other warning devices.**
- **If you are not fully familiar with proper repair procedures, do not attempt the checks, adjustments or repairs described on these pages.**

- **Always support your car with suitable stands if it is necessary to work underneath the vehicle.**
- **The jack supplied with the car is not adequate for this purpose.**
- **Be extremely cautious when working on any part of the car to prevent accidental injury. Remove neckties or necklaces; tie long hair back behind your head. Disconnect the battery ground cable after turning off the engine before working on the electrical or fuel system to prevent sparking. Only connect battery if this is necessary for certain tests.**

**Note: The adjustment of idling and ignition timing requires special equipment and should only be carried out by an authorized dealer.**

Locate the condition and probable cause of your trouble in the list on the following pages and follow the directions on what to do. If the trouble is serious or if you are uncertain as to its origin, be sure to see an authorized dealer or qualified mechanic as soon as possible.

**See also CAUTIONS on page 56.**

If you are not fully familiar with proper repair procedures, do not attempt the checks or repairs described on this page. See also CAUTIONS on page 56.

PROBLEM	PROBABLE CAUSE	WHAT TO DO
Car will not start: engine will not turn over or turns over too slowly.	<ol style="list-style-type: none"> <li>1. Run down or dead battery.</li> <li>2. Loose connection               <ol style="list-style-type: none"> <li>A. At battery</li> <li>B. At starter</li> <li>C. At ignition switch or fuse box</li> </ol> </li> </ol>	<ol style="list-style-type: none"> <li>1. Charge or replace battery.</li> <li>2. Make sure that all connections are tight.               <ol style="list-style-type: none"> <li>A. Check both cable connections on battery and grounded end of ground strap.</li> <li>B. Check connections at solenoid, mounted on starter, under right rear of vehicle.</li> <li>C. Check push-on connections behind dashboard.</li> </ol> </li> </ol>
	<ol style="list-style-type: none"> <li>3. Starter failure</li> <li>4. On vehicles with Automatic Transmission: The selector lever is not in starting position</li> </ol>	<ol style="list-style-type: none"> <li>3. Ask for assistance.</li> <li>4. Shift into Neutral or Park.</li> </ol>
Car will not start: engine turns over.	<ol style="list-style-type: none"> <li>5. Improper starting procedure.</li> <li>6. No fuel in tank</li> </ol>	<ol style="list-style-type: none"> <li>5. Refer to "Starting hints".</li> <li>6. Fill up tank.</li> </ol>

**If you are not fully familiar with proper repair procedures, do not attempt the checks or repairs described on this page. See also CAUTIONS on page 56.**

PROBLEM	PROBABLE CAUSE	WHAT TO DO
	<ul style="list-style-type: none"><li>7. Dampness in engine compartment.</li><li>8. Dampness in distributor.</li><li>9. Spark plugs wet, sooty or dirty.</li><li>10. Other failures in ignition or fuel injection system.</li></ul>	<ul style="list-style-type: none"><li>7. Dry ignition coil, ignition wires and distributor components.</li><li>8. Remove distributor cap and rotor and dry them carefully, especially inside of cap , with lint-free cloth.</li><li>9. Install new plugs and check electrode gaps (0.028 in/0.7 mm)</li><li>10. Contact nearest VW dealer.</li></ul>
Engine stalls shortly after starting.	11. Poor fuel supply.	11. See paragraphs 13 and 14.

If you are not fully familiar with proper repair procedures, do not attempt the checks or repairs described on this page. See also CAUTIONS on page 56.

PROBLEM	PROBABLE CAUSE	WHAT TO DO
<p>Engine stalls while vehicle is driven.</p>	<p>12. Failure in ignition system.</p> <p>13. Fuel supply is exhausted.</p> <p>14. Fuel filter may be clogged, gasoline may be contaminated by water or dirt.</p>	<p>12. See paragraph 7 through 8.</p> <p>13. Check whether any gasoline is left in tank.</p> <p>14. See your VW dealer for cleaning of all components of the fuel system.</p>
<p>Red warning light for oil pressure comes on while you are driving. (Brake warning light also comes on due to design of electrical system. In case of brake failure, <b>only brake warning</b> light will come on).</p>	<p>15. If light goes on, the oil pressure is too low.</p>	<p>15. Stop at once and check oil level. Add oil as necessary. If the oil level is sufficient and light goes on during driving, contact the nearest VW dealer before driving on.</p>
<p>Red warning light for alternator comes on while you are driving.</p>	<p>16. A fuse in the fuse box (see page 42) may be blown.</p> <p>17. The V-belt may be torn or slipping or alternator does not charge.</p>	<p>16. Replace fuse. If it blows again, do not drive on, because the turn signals will not work. Ask for assistance.</p> <p>17. If belt drives alternator without slipping, switch off all unnecessary electrical equipment (radio, etc.). Drive to nearest VW dealer as otherwise the battery will soon run down.</p>

---

# EMISSION CONTROL SYSTEM

---

## In the Interest of Clean Air

Pollution of our environment has become a problem that is of increasing concern to all of us. We urge you to join us in our efforts for cleaner air in controlling the pollutants emitted from the automobile.

Volkswagen has long recognized its responsibilities not only toward its customers but also toward the public in general.

We have developed an emission control system that controls or reduces those parts of the emission that can be harmful to our environment your Volkswagen is equipped with such a system.

Volkswagen warrants your new vehicle under the terms and conditions set forth in the Warranty and Maintenance booklet. You, as the owner of the vehicle, have the responsibility to provide regular maintenance service for the vehicle, as specified in the Maintenance Schedule, and to keep a record of all maintenance work performed. Authorized Volkswagen dealers have VW trained mechanics and special tools to offer fast, efficient service.

## How Emission Control Works

When an automobile engine is running, it uses energy generated through the combustion of a mixture of air and fuel. Depending on whether a car is driven fast or slow or whether the engine is cold or hot, some of the fuel (hydrocarbons) may not be burned completely but be discharged into the engine

crankcase or exhaust system. Additional hydrocarbons may enter the atmosphere through evaporation of fuel from the fuel tank. These hydrocarbons released into the air contribute to undesirable pollution.

In addition, carbon monoxide (CO) and oxides of nitrogen (NOx) contribute to harmful engine emissions. They, too, are formed during combustion and discharged into the exhaust system.

To reduce these pollutants all Volkswagens are equipped with a special emission control system.

**Your Volkswagen may have all or part of the following major components:**

### Controlled Combustion System

The amount of pollutants emitted from an engine greatly depends on the combustion of the air/fuel mixture. Complete burning of the air/fuel mixture is, therefore, very important. An improved combustion process in your Volkswagen makes it possible to keep harmful emissions from the engine at the required low level.

Your Volkswagen is equipped with a precisely calibrated fuel injection system to assure a finely balanced air/fuel mixture under all operating conditions.

The fuel injection system also monitors the ignition distributor via a vacuum line to assure ignition exactly the right moment for complete combustion.

## Crankcase Ventilation

Through crankcase ventilation harmful emissions from the engine crankcase are not permitted to reach the outside atmosphere. These emissions are recirculated to the air cleaner. From here the emissions mix with the air/fuel mixture in the intake system and are later burned in the engine (see illustration).

## Exhaust Gas Recirculation (EGR) (U.S. and Canada models)

Some of the exhaust gas from the engine is diverted before it enters the muffler. This gas is routed back into the intake manifold. An exhaust gas recirculation valve controls the flow to the intake manifold. The exhaust gas recirculated into the combustion chambers of the engine helps lower the formation of oxides of nitrogen (NOx) during the combustion process (see illustration).

## Catalytic Converter (U.S. models)

The catalytic converter is an efficient "clean up" device built into the exhaust system of your car to further help reduce engine pollutants. Harmful carbon monoxide and hydrocarbons in the exhaust gas are chemically changed into harmless carbon dioxide and water vapors before they pass to the outside through the muffler (see illustration).

The use of **unleaded fuel**, however, is **critically important** for the life of the converter. Deposits from leaded gasolines and fuel additives containing sulfur, zinc, nickel or barium will ruin the catalyst and make it ineffective as an emission clean-up device. Therefore, **only unleaded gasoline without harmful additives must be used.**

## Emission Control System

(U. S. and Canada models; California models see next page)

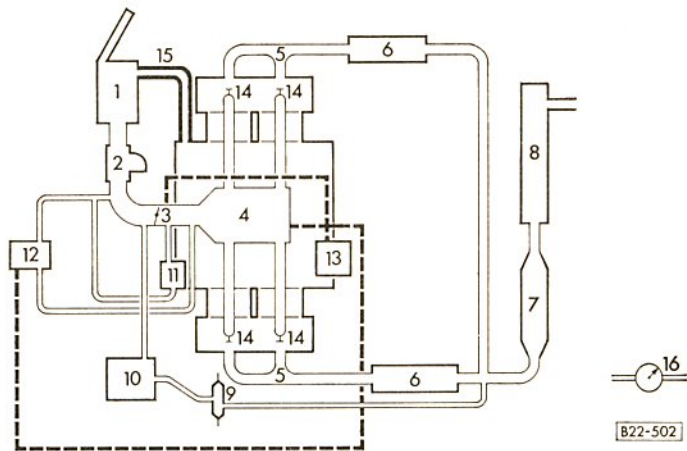

- |                            |                              |
|----------------------------|------------------------------|
| 1 – Air cleaner            | 10 – EGR-valve               |
| 2 – Air sensor             | 11 – Auxiliary air regulator |
| 3 – Throttle valve         | 12 – Decel. control valve    |
| 4 – Intake air distributor | 13 – Ignition distributor    |
| 5 – Exhaust manifold       | 14 – Fuel injector           |
| 6 – Heat exchanger         | 15 – Crankcase ventilation   |
| 7 – Catalytic converter    | 16 – Indicator light for EGR |
| 8 – Muffler                | (not connected in            |
| 9 – EGR-filter             | Canada models)               |

———— Exhaust and air lines  
- - - - - Control lines (vacuum)

## Fuel Evaporation Control

The sealed Volkswagen fuel evaporation system prevents gasoline vapors from escaping to the atmosphere through the following controls:

### Fuel tank venting

An expansion chamber for the fuel tank and vent lines are part of the fuel tank vent system. These components prevent fuel from escaping to the outside at extreme high outside temperatures and when the car is driven or parked at an incline or in any other non-level position.

### Activated charcoal filter

Vapors from the fuel tank are trapped in a container filled with activated charcoal. The filter is connected to the fuel tank vent system. This is how it works:

Fuel vapors pass through the filter and deposit hydrocarbons on the surface of the charcoal filter element. When the engine is running, fresh air entering the activated charcoal filter through an opening cleans the filter and routes these hydrocarbons via the air cleaner back to the engine where they are burned during normal combustion.

How fuel evaporation control works is shown in the illustration.

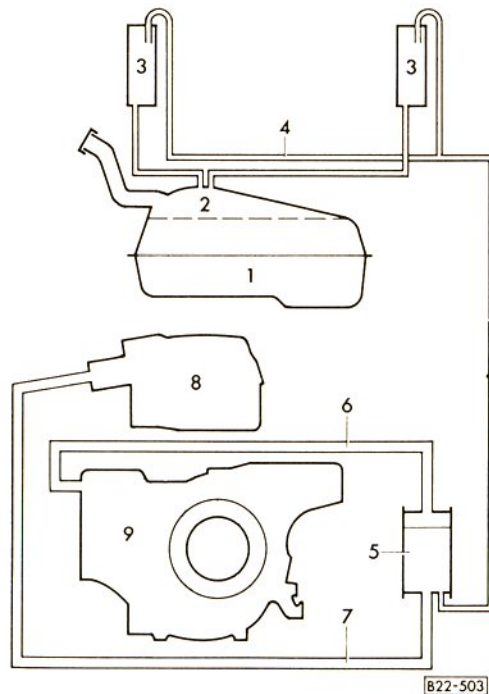

- |                       |                               |
|-----------------------|-------------------------------|
| 1 – Fuel tank         | 5 – Activated charcoal filter |
| 2 – Expansion chamber | 6 – Vent line                 |
| 3 – Separator         | 7 – Vent line                 |
| 4 – Vent line         | 8 – Air cleaner               |
|                       | 9 – Fan housing               |

# An important word of CAUTION on the Emission Control System in your car

Your car is equipped with an Emission Control System. The major components of this system are **Exhaust Gas Recirculation (EGR)** (not on California models) **Oxygen Sensor (OXS)** (California cars only) and **Catalytic Converter** (not on Canada models).

The **EGR system** is designed to recirculate a portion of the exhaust gases into the combustion chambers of the engine, and thus helps lower the formation of oxides of nitrogen (NOx).

The **catalytic converter**, an efficient "clean-up" device built into the exhaust of your car, changes carbon monoxide and hydrocarbons in the exhaust gas into carbon dioxide and water vapors and on California models also lowers the formation of oxides of nitrogen (NOx) before being released to the atmosphere.

To assure efficient operation of the Emission Control System:

- **Have your car maintained properly in accordance with the service recommendations listed in the Warranty & Maintenance booklet. Lack of proper maintenance, especially of the fuel and ignition systems, as well as improper use of the vehicle could lead to damage.**
- **Do not alter or remove any component of the Emission Control System unless approved by the manufacturer.**
- **Do not alter or remove any device, such as switches and valves, which are designed to protect your car and the environment.**
- **Do not continue to operate your vehicle if you detect engine misfire or other unusual operation conditions.**

## Starting

Do not leave car engine idling unattended after starting. If warning lights should come on to indicate improper operation, they would go unheeded. Extended idling also produces heat, which could result in overheating or other damage to the car.

## Parking

As with any vehicle, do not park or operate your car in areas where combustible materials, such as dry grass or leaves, can come into contact with a hot exhaust system.

## Undercoating

Do not apply additional undercoating or rustproofing on or near the exhaust manifold, exhaust pipes or catalytic converter. During driving, the substance used could overheat and cause a fire.



## **CARS WITH CATALYTIC CONVERTER**

(U.S. models)

**Do not turn the ignition off while the car is moving. Immediate damage to the catalytic converter will result if you turn the ignition off while your car is moving, or if you try to push-start the car... because under these conditions unburned fuel can reach the catalytic converter.**

**Do not drive if you detect engine misfire or other unusual operating conditions, as this could result in overheating of the catalytic converter or other damage to the vehicle.**

<b>Transmissions</b>	<p><b>Automatic Transmission</b> Automatic Transmission combined with final drive. The transmission consists of a hydrodynamic torque converter and planetary gearing with three forward gears and one reverse. Drive shafts with two constant velocity joints per shaft.</p> <p><b>Manual Transmission</b> Single plate dry clutch. Clutch pedal, free play: <math>\frac{3}{8}</math> -1 in (10-25 mm) Balk sychronized four-speed transmission and bevel gear differential in one housing. Drive shafts with two constant velocity joints per shaft.</p>
<b>Body/Chassis</b>	<p>Unitized body, frame plates reinforced with side and cross members, front axle bolted to frame side members, engine/transmission suspended in 4 bonded rubber mountings.</p>
<b>Steering:</b>	<p>Roller steering with maintenance-free tie rods and hydraulic steering damper.</p>
<b>Front wheel suspension:</b>	<p>Independent torsion arms with ball joints, stabilizer, telescopic shock absorbers.</p>
<b>Rear wheel suspension:</b>	<p>Independent double jointed axle with trailing arms and diagonal links. Torsion bar, telescopic shock absorbers.</p>
<b>Service (foot) brake system:</b>	<p>Hydraulic dual-circuit power-assisted brake system with pressure regulator for rear wheel circuit. Front wheels with disc brakes, rear wheels with drum brakes.</p>
<b>Parking brake system:</b>	<p>Mechanical, effective on rear wheels.</p>
<b>Tires:</b>	<p>Tubeless radial ply — 185 R 14 <b>C</b> 6 PR* or 185 SR 14 <b>Reinforced</b> * The "C" type tire also bears the label "Load range C." See page 53</p>
<b>Wheels, Tire and Rim size and Tire pressure:</b>	<p>see sticker on the steering column bracket.</p>

**Capacities**

	U.S.	Metric
Fuel tank .....	14.6 gal	ca. 55 liters
Reserve (of total capacity) .....	1 gal	4 liters
Engine oil with filter change .....	3.7 qt	3.5 liters
Engine oil without filter change .....	3.2 qt	3.0 liters
Manual Transmission and final drive* .....	3.7 qt	3.5 liters
Automatic Transmission:		
Torque converter and planetary gears		
at change .....	3.2 qt	3.0 liters
Final drive* .....	1.5 qt	1.4 liters
Windshield washer container .....	1.5 qt	1.4 liters

\* Does not have to be changed

**Performance**

Maximum and cruising speed ..... 75 mph or 120 km/h

## Electrical system

Voltage .....	12 Volt
Battery .....	54 Ah on U.S. models, 63 Ah on Canada models
Additional battery for Campmobile with refrigerator .....	45 Ah
Starter .....	1.1 hp
Alternator .....	max. 55 Amp. (770 Watt) on U. S. models, max. 70 Amp. (980 Watt) on Canada models
V-belt size .....	9.0 x 965
Ignition distributor .....	with combined vacuum and centrifugal spark control and speed limiter
Firing order .....	1—4—3—2
Ignition timing .....	for correct specification for your engine, see label in engine compartment
Contact breaker gap (where applicable).	0.016 in (0.4 mm)
Spark plugs .....	Bosch W 145 M2 Beru 145/14/3 L Champion N-288
Plug thread .....	14 mm
Electrode gap .....	0.028 in (0.7 mm)

Dimensions	Wheelbase . . . . . 94.5 in (2400 mm)				
	Turning circle diameter . . . . . approx. 40 ft (12.3 m)				
	Track at front (at gross vehicle weight) 54.8 in (1395 mm)				
	Track at rear (at gross vehicle weight) 57.2 in (1455 mm)				
Weights		Station Wagon	Kombi	Camp-mobile	Delivery Van
	Length in/mm . . . . .	177.4/4505	177.4/4505	177.4/4505	177.4/4505
	Width in/mm . . . . .	67.7/1720	67.7/1720	67.7/1720	67.7/1720
	Height, unladen in/mm . . . . .	77.0/1955	77.0/1955	80.0/2032	77.2/1960
	Ground clearance in/mm . . . . .	7.8/ 200	7.8/ 200	7.8/ 200	7.8/ 200
	Unladen weight lb/kg . . . . .	3042/1380	2921/1325	3296/1495	2744/1245
	Vehicle capacity weight (payload) lb/kg	1918/ 870	2149/ 975	1665/ 755	2326/1055
	Gross vehicle weight lb/kg . . . . .	4960/2250	5070/2300	4961/2250	5070/2300
	Gross axle weight front lb/kg . . . . .	2227/1010	2227/1010	2227/1010	2227/1010
	Gross axle weight rear lb/kg . . . . .	2800/1270	2866/1300	2800/1270	2866/1300
	<b>Perm. roof and trailer weights<sup>1)</sup>:</b>				
Roof weights lb/kg . . . . .	220/100*	220/100*	110/ 50*	220/100*	
Trailer without brakes (lb/kg) . . . . .	1322/ 600	1322/ 600	1322/ 600	1322/ 600	
Trailer with brakes (lb/kg):					
Manual Transm. on gradients   . . . . .	2645/1200	2645/1200	2645/1200	2645/1200	
Automatic Transm. up to 16%   . . . . .	1763/ 800	1763/ 800	1763/ 800	1763/ 800	
Perm. trailer tongue load lb/kg max . . . . .	110/50	110/50	110/50	110/50	

<sup>1)</sup> Trailer weights listed are in accordance with maximum vehicle engine and brake capacity. They apply to gradients specified up to 3000 ft/1000 m above sea level. For higher altitudes, vehicle and trailer loads should be reduced by 10% for each additional 3000 ft/1000 m. The listed weights also depend on the weight rating specified by the trailer hitch manufacturer.

\* Applies only to roof rack mounted to rain gutters or roof luggage rack (Campmobile with Pop-Up Roof). Distribute load evenly.

# Lubricants

## Engine oil

Always use quality oil labeled "For Service API/SE" for the engine of your Volkswagen.

Engine oils are graded according to their viscosity. The proper grade to be used in your engine depends on existing climatic or seasonal conditions.

The table on the right contains the grading for oils to be used in your VW engine.

As temperature ranges of the different oil grades overlap, **brief** variations in outside temperatures are no cause for alarm. It is also permissible to mix oil of different viscosities if you find it necessary to add oil.

## Transmission oil

Hypoid oil	Single-grade	Multi-grade	Specifications
Manual Transmission	SAE 80 W	Sae 80 W-90	MIL-L-2105 API/GL 4
Final drive of the Automatic Transmission	SAE 90	-	MIL-L-2105 B API/GL 5

Automatic Transmission and torque converter require ATF all year round. All ATF's labeled Dexron® can be used.

## Lubricant additives

If your Volkswagen is properly maintained, it is uneconomical to mix any type of additive with lubricating oils and transmissions fluids.

## Grease

**Multi-purpose grease with lithium base** should be used for the front axle.

**Dry stick lubricant** should be used for the hood locks and the sliding surfaces of the striker plates.

**Silicone spray or petroleum jelly** should be used for the battery terminals and posts.

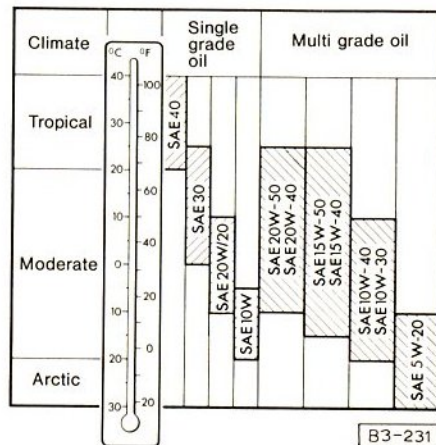

When using single grade SAE 10W or multi grade SAE 5W-20 engine oil avoid high speed long distance driving if outside temperature rises above the indicated limits.

# GAS STATION INFORMATION

## Starting

Manual Transmission – Start in Neutral.  
Autom. Transmission – Start in Neutral or Park.

It is not necessary to depress accelerator. Fuel injection system supplies required amount of fuel for starting.

## Driving ranges

See shift pattern on ashtray.

## Chassis number (Serial No., VIN)

Visible through driver's side of windshield.

## Driver's seat

To **adjust seat**, push or pull lever (1) on left.

To **adjust backrest**, push lever (2) down on inboard side of seat.

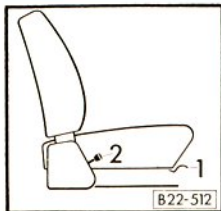

## Fuel cap

Above right rear wheel.

## Fuel recommendation

UNLEADED FUEL ONLY for cars so marked.

REGULAR, 91 RON, for cars not specially marked. See page 28.

## Engine oil dipstick

Check oil level 5 min. after engine has stopped. Level should be between upper and lower marks on dipstick.

The difference between the two marks is about 0.5 U.S. quarts (0.4 Imp. qt./0.5 liter).

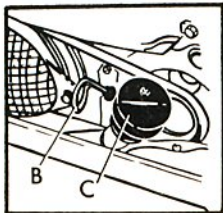

B = dipstick  
C = oil filler cap

## Engine oil grades

Use quality oil labeled "For Service API/SE". See oil viscosity chart on page 83.

## Transmission oil

Manual Transmission – hypoid oil\* SAE 80 W or SAE 80 W-90 (multi-grade), MIL-L-2105 API/GL 4.

**Automatic Transmission:** final drive – hypoid oil\* SAE 90, MIL-L-2105 B, API/GL 5.

\*Lifetime filling

## ATF (Automatic Transmission)

Check ATF level when ATF is warm, with engine idling, selector lever in Neutral and parking brake applied. ATF tank cap has dipstick attached.

Use ATF "Dexron®".

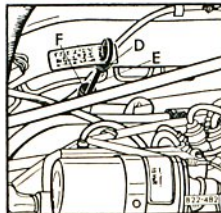

D = filler cap  
E = dipstick  
F = fluid tank

### Brake fluid reservoir

Under driver's seat. Brake fluid level should be between upper and lower edge of reservoir.

Only use new, unused DOT 3 or DOT 4 brake fluid SAE J 1703, conforming to Mot. Veh. Safety Std. 116.



Do not add or mix DOT 5 silicone type brake fluid with the brake fluid in your car as severe component corrosion may result. Such

corrosion could lead to brake system failure.

**Fuses and relays** – under dashboard, left side

**Additional fuses for:**

Back-up lights – in engine compartment on the left near wheel housing.

Warm air blower – in engine compartment near blower motor.

See pages 42 and 43.

**Plug connector for electric fuel pump** – in engine compartment on left side.

### Tire pressure

See sticker on left doorjamb.

**Battery** – in engine compartment  
Check fluid level through transparent battery housing. Top up with distilled water.

**Campmobile** with refrigerator has two batteries.

### Towing – Manual transmission

Place gearshift lever in Neutral.

Turn ignition on.

Release parking brake.

### Towing – Automatic Transmission

Place lever in Neutral.

Turn ignition on.

Release parking brake.

### When lifting at front:

**Max. towing speed** – 30 mph or 48 km/h.

**Max. towing distance** – 30 miles or 48 km.

Limitations do not apply if car is lifted at **rear** or if drive shafts are disconnected.

**Windshield washer container** – under dashboard right hand side.

Fill with water and cleaning solution.

Follow mixture instruction on can.

After filling, screw on cap tightly.

Pressurize container up to 42 psi (3.0 kg/cm<sup>2</sup>) through container hose.

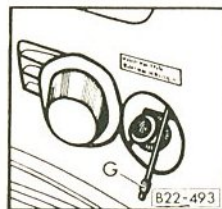

G = Pressurize via valve.

### Spare wheel

In rear luggage compartment or under front seat bench.

**Campmobile:** Spare tire is stored in sink cabinet.

**Jack and tool kit** – under front seat or bench.

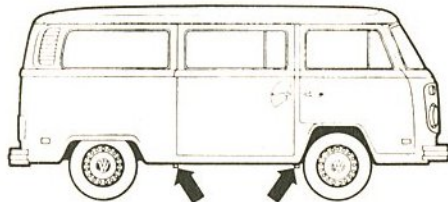

**Jack ports** – two on each side for front and rear wheel changing.

**Do not jack up car by the bumper or body.**



## At a glance ...

### ENGINE

Horsepower SAE net	67 at 4200 rpm
No. of cylinders	4
Displacement	1970 cm <sup>3</sup> (120.2 cu in)
Type	horizontally opposed, rear mount
Cooling	air cooling by fan on crankshaft
Fuel / air supply	AFC fuel injection
Fuel tank capacity	14.6 U.S. gal/12 Imp. gal/55 liters
Engine oil capacity:	
with filter change	3.7 U.S. qt/3.1 Imp. qt/3.5 liters
w/o filter change	3.2 U.S. qt/2.6 Imp. qt/3.0 liters

VEHICLE LENGTH	177.4 in/4505 mm
WIDTH	67.7 in/1720 mm
HEIGHT*	
– Station Wagon	77.0 in/1955 mm
– Campmobile	80.0 in/2032 mm

\* unladen

### BRAKES

dual circuit power-assisted  
discs front, drums rear

### SUSPENSION

4-wheel independent

### STEERING

roller steering

### DRIVE TRAIN

Type	rear wheel drive
Gears (Manual)	4 forward, 1 reverse
Speeds (Automatic)	3 forward, 1 reverse

### ELECTRICAL SYSTEM

Battery                      U.S.: 12 Volt/54 Ah  
                                    Canada: 12 Volt/63 Ah

### Alternator

                                    U.S.: 55 Amp. max.  
                                    Canada: 70 Amp. max.