

VOLKSWAGEN

Karmann-Ghia

1500





VOLKSWAGEN

Karmann-Ghia

1500

Instruction Manual

August 1964

V O L K S W A G E N W E R K A G · W O L F S B U R G

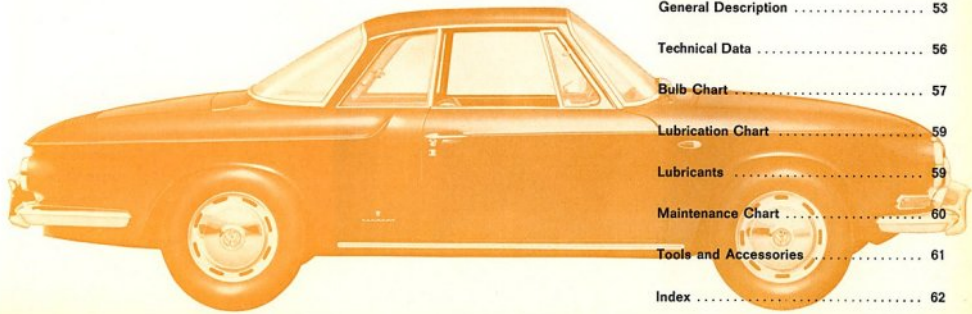

Identification Plate, Chassis and Engine Number	4
Controls and Instruments	5
Operating Instructions	6
Practical Driving	18
Cold Weather Hints	22
Care of the Tires	24
Care of the Car	26
Lubrication	29
Maintenance	34
General Description	53
Technical Data	56
Bulb Chart	57
Lubrication Chart	59
Lubricants	59
Maintenance Chart	60
Tools and Accessories	61
Index	62



Identification plate, Chassis and Engine Number. The model designation and the chassis and engine numbers are entered in the vehicle documents. The police or Traffic Department attach much importance to these details.

The **identification plate** is found near the filler neck of the fuel tank under the front hood.



The **chassis number** is found on the frame tunnel under the emergency seat.



The **engine number** is found between oil cooler and air cleaner near the crankcase joint.

- 1 - Vent wing handle
- 2 - Switch for windshield wipers and washer system
- 3 - Switch for lights and instrument lighting
- 4 - Warning light — Green — Fog lights
- 5 - Warning light — Blue — Headlight high beam
- 6 - Warning light — Red — Generator
- 7 - Fuel gauge
- 8 - Warning light — Green — Flashing indicators
- 9 - Warning light — Green — Oil pressure
- 10 - Speedometer
- 11 - Clock
- 12 - Cigarette lighter
- 13 - Fresh air ventilation lever — left
- 14 - Fresh air ventilation lever — right
- 15 - Loudspeaker grille
- 16 - Locking lever
- 17 - Inner door handle
- 18 - Window winder
- 19 - Front hood control knob
- 20 - Flashing indicator switch
- 21 - Horn lever
- 22 - Steering ignition lock
- 23 - Clutch pedal
- 24 - Brake pedal
- 25 - Accelerator pedal
- 26 - Ash tray
- 27 - Heating control lever
- 28 - Hand brake lever
- 29 - Gear lever
- 30 - Control lever for heating in rear foot well

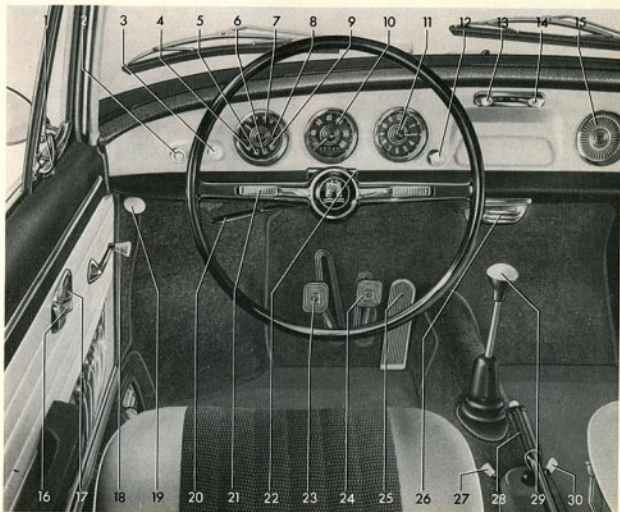

Operating Instructions

Before driving off acquaint yourself with your new car. You have been given a separate key for the door locks and the steering ignition lock. You should take note of the key numbers so that you can get a replacement from your VW workshop if you should you lose a key.

Both Doors can be unlocked from the outside. A quarter of a turn with the key and the door can be opened by means of the press button under the door handle.

Both doors can be locked from the outside. It is, however, more convenient to push in the lever above the inner door handle and to depress the button below the outer door handle. If the door closes unintentionally after the inner lever has been depressed it will not lock and thus the danger of getting locked out is reduced to a minimum.

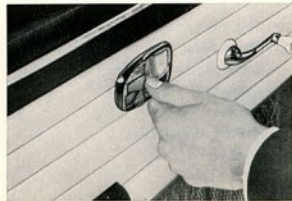



The **front seats** can be adjusted individually whilst driving by pulling up the lever at the front of the seat.

The rake of the backrest can be adjusted by turning the knob at the front of the seat. The backrest can also be reclined by turning the knob.



Pull up the knob at the backrest mounting to tilt the backrest forward.

Emergency Seat. The bench seat behind the front seats is for children or can serve as an emergency seat. The bench seat back is held in the normal position by a rubber strap.

When folded down the back adds to the luggage platform area.



The Rear View Mirrors are adjustable and should be set to give clear vision to the rear at all times without having to alter ones position.

The windshield wipers are controlled by the left pull switch on the instrument panel. The wipers park automatically when switched off and the speed can be regulated by turning the switch.

The windshield washer system is operated with the button fitted in the wiper switch. The windshield washer is pneumatically operated so that by just pressing the button once you can spray water on to the windshield until the wipers have cleaned the glass properly.

The Sun Vizors can be swivelled towards the door windows to offer protection against the sun from the side.

The water container is located near the spare wheel under the front hood and holds about 1 liter (1 quart). Do not forget to fill the

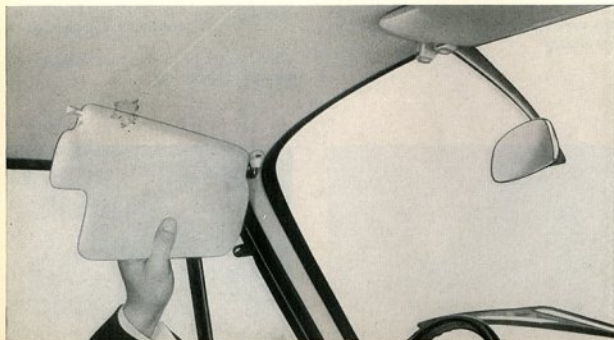

container from time to time. The partition between the spare wheel well and luggage compartment can be folded to the rear to do this.

As the air pressure in the container escapes when the cap is removed, it is advisable to refill the container at a filling station. The container can be filled until it overflows. The pipe in the container neck ensures that there is always sufficient air to operate the washer.

The correct air pressure is 2.5 kg./cm² (36 psi.). The addition of 25 % pure spirit to the water in winter will protect it from freezing down to a temperature of approximately -12° C (10° F). An odourless anti-freeze solution can be used instead of methylated

spirits. The correct mixing proportions are given by the manufacturers.

The wiper blades should be removed occasionally and thoroughly cleaned with a hard brush and methylated spirits or a strong detergent solution. Particularly during long dry periods they tend to become clogged with tar splashes, oil and insects. The blades should be renewed once a year.

The lights are switched on with the right-hand pull switch on the instrument panel.

To switch on the parking light, the rear lights and the license plate light, pull the switch out to the first stop — you can feel the stop engage in this position. To switch the head-

lights on, pull the switch out to the second stop. The dimmer switch is located in the lever of the turn indicator switch on the steering column.

The instrument lighting can be varied in brightness by turning the knob of the lighting switch. It can also be switched off completely by turning the switch to the left as far as it will go.

The fog lamps are switched on by a tumbler switch under the instrument panel on the left side. They operate in conjunction with the low beams only. When the fog lamps are switched on, a green warning lamp in the fuel gauge dial lights up.

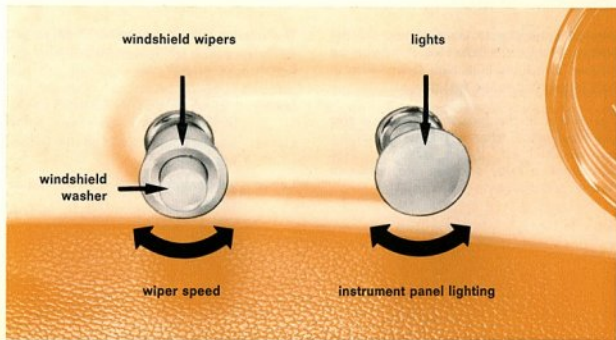



Flashing Indicator Lever. You can operate the flashing indicator lever with your finger without taking your hands off the steering wheel. Together with the button situated in it, the indicator lever has four functions:

With the ignition switched on the flashing indicators are operated:

- Lever upwards - right flashing indicator
- Lever downwards - left flashing indicator

Two warning lights in the fuel gauge flash whilst the indicators are in operation. The indicators are self-cancelling.

With the lever in the same positions and the ignition switched off, the left or right parking lamp is illuminated. The parking lamps are positioned on the sides of both front fenders.



When the headlights are switched on, the button in the indicator lever serves as dimmer switch. A blue high beam warning light is situated in the fuel gauge.

The button in the indicator lever operates the headlamp flasher when the headlights are switched off. If the button is kept depressed, a relay operates the headlamp flasher continuously.



The Interior light is situated above the left door. The switch which is incorporated in the light has three positions:

- Central Interior light comes on when a door is opened.
- Upper Interior light switched off when doors are open.
- Lower Interior light switched on with doors closed.



Fresh Air Ventilation

The fresh air ventilation for each side of the car can be regulated individually by the two levers in the center of the instrument panel. The fresh air enters through two vents at the lower edge of the windshield.

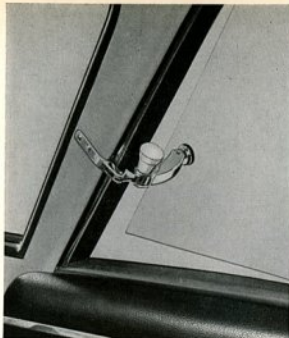

Further ventilation is provided by the vent wings in the door and the hinged quarter windows.

The warm and fresh air must be extracted to ensure correct vehicle ventilation. Even in cool weather a vent wing or hinged window should be opened slightly. The windows will then remain clear.



The Sliding Roof is electrically operated by the switch under the instrument panel to the left of the ash tray. To open the roof, pull the switch and push it forward to close it. The roof automatically remains in any position when you take your hand off the switch.



The Clock is electrically operated. The hands can be moved by turning the knob in the center of the dial.



The cigarette lighter is operated by pressing it in and releasing it. It will spring out a certain distance on attaining correct temperature.



The Ash Tray in the Instrument Panel can be removed by depressing the spring.



The Glove Compartment can be locked with the door key. The knob is fully depressed to open it.

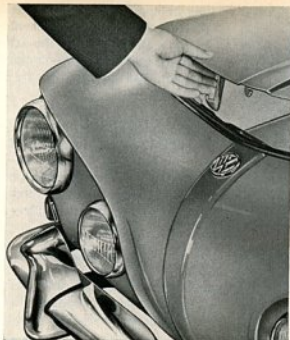

The front luggage compartment is theft-proof when the car is locked.

The knob for the front hood is situated under the instrument panel on the left. The hood is released when the knob is pulled and is opened by pressing back the catch beside the lock.



The rear luggage compartment is locked with the door key and opened by depressing the button above the licence plate.

However, to release the hood fully the catch pressure must be overcome. This is done by depressing the hood slightly.

The light in the rear luggage compartment operates only when the lights are on and goes out when the hood is closed.

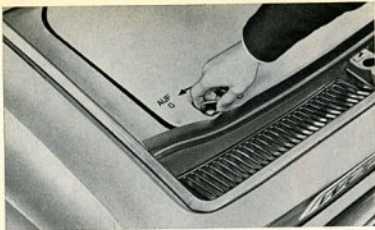

The **Engine Compartment** is accessible from the rear luggage compartment. Release the buttons and roll back the lining. Turn the handles on the engine compartment lid to the left. The lid can now be raised or removed.

When closing the lid make sure that it engages correctly in the hinges.

Turn the handles to the right to lock the engine compartment lid and secure them by pressing them down fully.

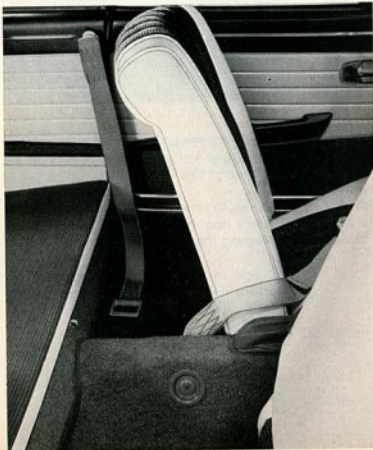

Safety Belts

can be obtained from every VW Dealer. The belts are attached to the lock pillar and the frame tunnel.

Practical Driving

Breaking-in instructions are not necessary for your car. The most modern production and inspection methods have made it possible to dispense with the initial speed restrictions which are normally required. You can drive the vehicle at full speed from the first day. It is advisable, however, to observe certain general driving rules.

Gear Shifting

Glance occasionally at the speedometer especially during the initial period.

Shift the gears within the permissible speed ranges only:

1st gear
0 to 30 kph (0—18 mph)



You can drive
very economically between:

2nd gear
10 to 60 kph (6—37 mph)



10 and 35 kph (6 and 21 mph)

3rd gear
25 to 90 kph (15—56 mph)



25 and 60 kph (15 and 37 mph)

Top gear
40 to 145 kph (25—90 mph)



40 and 110 kph (25 and 68 mph)

Do not race the engine in the individual gears. This practice can have a decisive effect on the life of the engine.

Engage the reverse gear only when the car is stationary. A locking device prevents unintentional shifting. Depress the gear lever slightly and then move it to the left and to the rear to engage reverse.

Before driving off

check the brakes, lighting, amount of fuel and at regular intervals the oil level and tires of your Karmann Ghia.

* Premium fuels with this octane rating are not available in every country. When in doubt, please consult your VW agent.

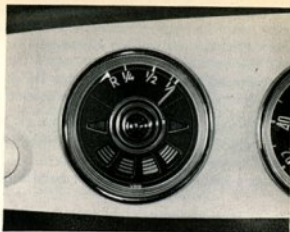

The fuel tank capacity of 40 liters (10.6 US gall.; 8.8 Imp. gall.) is sufficient for 450 km (280 miles). When the ignition is switched on the fuel gauge in the instrument panel will show you how much fuel you actually have. When the needle registers "R" (reserve) it is time to fill up at the next opportunity. The remaining 5 liters (1.3 US gall.; 1.1 Imp. gall.) in the tank will last for about 55 km (34 miles).

The twin-carburetor engine of your car must only be run on premium fuel with an octane rating of at least 95*. The choice of the brand of fuel is left to you. All good brands of fuel are distinguished by their consistent composition, adequate anti-knock properties and freedom from harmful ingredients. The fuel tank filler is under the front hood which is opened by means of the knob under the instrument panel.

The Brakes must be checked before starting out on a trip as the safety of your car depends mainly on them. When the car is in motion, depress the brake pedal a few times to make sure that the brakes are working efficiently.

The stop and flashing indicator lights are an essential part of the lighting system. The ignition has to be switched on if you wish to check them.

If a flashing indicator bulb is defective, the warning lights in the fuel gauge will come on and go out again. Moreover, the other indicator on the same side of the car will flash considerably quicker.

The stop lights only operate when the footbrake is applied.

The oil level can only be checked when the engine is not running. It must always be between the two marks on the dipstick and must never fall below the lower mark. Wipe the dipstick with a clean rag before checking the oil level.

If possible always use the same branded HD oil (for Service MS). It is not good practice to mix various brands of oil.

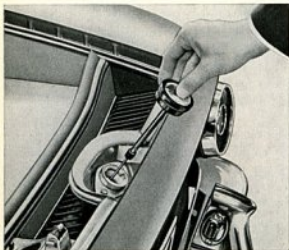

Tires

Correct tire pressures are essential for ensuring the excellent road-holding properties of your car. It is not expecting too much for you to check the tire pressures occasionally.

When the car is fully loaded, or when driving fast on long journeys the front tire pressure should be 1.2 kg./cm² (17 psi.) and 1.8 kg./cm² (26 psi.) at the rear. Otherwise 1.1 kg./cm² (16 psi.) pressure at the front and 1.7 kg./cm² (24 psi.) at the rear is sufficient.

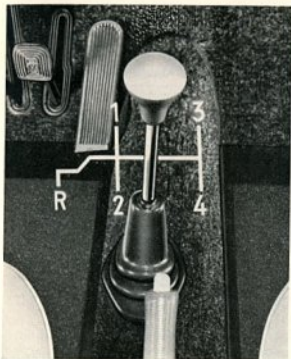

Shifting to lower gear

Shift down to a lower gear in good time when on inclines and also when accelerating from low speeds. The transmission of your car is fully synchronized so please do not hesitate to shift the gears.

Certain speed ranges have to be adhered to when shifting to a lower gear. Shifting down to a lower gear at excessive speeds puts an unnecessary strain on the transmission. On the other hand very low speeds in the individual gears are harmful to the engine. Shift down from 4th to 3rd gear approximately between 90 and 40 kph (56 and 20 mph) and from 3rd to 2nd gear between 60 and 25 kph (37 and 15 mph). The 1st gear is only used for moving off, driving at walking pace or on very steep inclines.

When shifting gears, it is absolutely essential to depress the clutch pedal fully. Incomplete declutching makes gear shifting difficult and leads to rapid wear of the synchronizer stop rings.

Brakes

The brake responds to even the slightest foot pressure. Apply the brakes carefully and avoid locking the wheels. Locked wheels will not shorten the braking distance but may cause you to lose control over the vehicle and will affect the tires.

When driving downhill, make use of the braking effect of the engine and shift to that gear which you would use in driving uphill. The ignition must never be switched off when going downhill.

Violent braking can only be justified in an emergency. Nevertheless, it is advisable to check the full braking effect at certain intervals so that you will be familiar with the behaviour of the car and the actual braking distance.

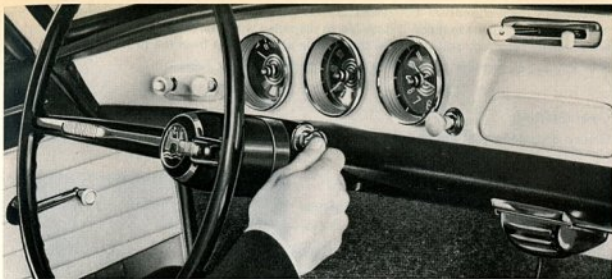

Starting the Engine

The ignition and starter are switched on, one after the other, by means of the steering ignition lock. As starter operation stresses the battery heavily, other big current users, such as the headlights, windshield wiper and radio, should not be switched on when starting. Make sure, also, that the gear shift lever is in neutral.

When switching on the ignition, turn the key half a turn from the "Halt" position or a quarter of a turn from the "Garage" position to the right. The red generator warning light and the green oil pressure warning light in the fuel gauge will come on. Operate the starting motor immediately by turning the key further to the right.

At temperatures above freezing point or when the engine is still warm, depress the accelerator pedal slightly while operating the starter. Depress the acceleration pedal fully only when the engine is very warm.

At temperatures below freezing point and when the engine is cold, depress the accelerator pedal fully and then release it slowly before switching on the ignition. This enables the automatic chokes to close the choke valves. As the engine and transmission oil tend to become thick when cold, you should also declutch when starting so that the starter motor only has to turn the engine.

As soon as the engine starts, release the ignition key so that the starter is switched off. You can move off at once. The automatic chokes regulate the mixture and idling speed to suit the operating temperature. Do not race the engine when it is still cold.

If the engine does not start within the first 10 seconds, pause for about the same length of time to rest the battery before repeating the starter operation. The ignition will have to be switched off first and then on again as a non-repeat lock in the switch prevents the starter from being operated repeatedly when the ignition is on and thus prevents it from being damaged by the engine when it is running. The starting procedure should not be interrupted if the engine is heard to fire a few times without starting.

The generator warning light goes out when the engine speed increases. If it comes on while you are driving, the generator is no longer charging. In this case you can proceed but if possible only as far as the next workshop as otherwise the battery will soon run down.

The warning light for the oil pressure goes out when the engine is started. If this warning light comes on whilst driving you must stop at once as the chances are that the oil circulation has been interrupted. Check the oil level at once. If the oil level is correct, get in contact with the nearest VW workshop.

If the light flashes occasionally when the engine is warm and running slowly it does not indicate trouble.

Caution. Be careful when starting the engine in the garage. Provide ample ventilation so that the exhaust fumes, which contain carbonmonoxide gas, can escape.

Economical operation is one of the outstanding features of your car. However, getting a few extra miles from each gallon depends on your driving habits:

Make use of the lower speed ranges of the individual gears. For instance on level roads at a speed of between 40 and 60 kph (25 and 37 mph) use the 4th gear in preference to the 3rd gear.

Accelerate gradually. Under normal driving conditions shift to 2nd gear at 10 kph (6 mph) to 3rd gear between 25 and 35 kph (15 and 22 mph) and to 4th gear between 40 and 60 kph (25 and 37 mph).

Only use the full acceleration and excellent braking effect of your car when it is absolutely necessary.

Do not pump the accelerator pedal unnecessarily. Even the small quantity of fuel additionally discharged each time the accelerator pedal is depressed results in a marked increase in the overall fuel consumption.

Do not continue to accelerate on inclines when your speed drops, shift in good time to a lower gear. There are, however, no hard and fast rules for this: If, for instance, the speed drops on an incline in 4th gear from 110 kph (68 mph) to 90 kph (56 mph) and lower, it is best to shift to the 3rd gear between 80 and 70 kph (50 and 43 mph). If you are driving at a speed of between 40 and 60 kph (25 and 37 mph) in 4th gear on a level road shift to 3rd right at the beginning of the incline.

Reduce your speed in good time before corners and when stopping. Do not coast downhill.

High speeds always result in increased fuel consumption. When accelerating, depress the accelerator pedal slowly and only to such an extent as is necessary to reach the desired speed. On long journeys in particular this method will prove very economical.

The most advantageous engine operating conditions result from brisk driving and correct gear shifting.

Parking

Parking in limited spaces can be made quite simple:

Stop your car level with the car in front of the space. Turn the steering wheel sharp to the right and reverse slowly into the gap:



When the front bumper of your car is level with the rear bumper of the car ahead of you, turn the steering wheel fully to the left and back up further towards the curb:

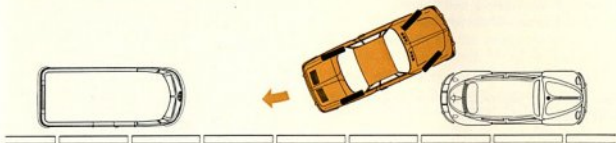

Now turn the steering wheel to the right again and pull up a little bit, until both ends of the car come as close to the curb as possible:



When parking on a steep slope, set the handbrake and also engage first or reverse gear. Remove the key at the "Halt" position only when the vehicle is stationary. This locks the steering and protects the vehicle against theft.

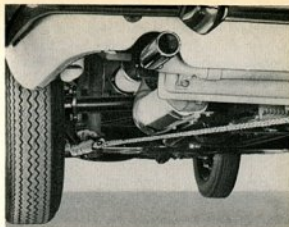

Towing

Just in case you wish to attach a towrope to your vehicle one day, please note that the bumpers are not suitable for this purpose. At the rear we advise you to attach the rope to a lower shock absorber bracket. This point is not very easy to reach but it at least ensures that your desire to help does not result in damage to your vehicle.

At the front, the rope should be attached to the lower axle tube.

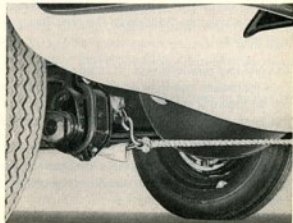

Cold Weather Hints

Your car has two features which you will most appreciate: Air cooling and heating. You can expose your car to bitter cold without fear. Its air-cooled engine will always be ready to start and supply warm air for the interior of the car.

The warm air heating can be fully regulated. The distribution of warm air can be varied to suit the wishes of the occupants by means of controllable outlets at foot level.

The left-hand lever between the front seats turns all the heating on and off and the right-hand lever controls the heating in the rear foot well. The outlets in the front foot well can be closed with slides.

At very low temperatures, it is advisable to always close the rear outlets when first moving off. This increases the flow of air to the windshield and the rear window and also helps to prevent the windows from steaming up when air humidity is high. As soon as the windshield is clear, the rear foot level outlets should be opened so that the interior of the body heats up as quickly and uniformly as possible.

If you open a vent wing or a quarter window when the heating is on, the heater output will increase noticeably because the engine fan can then force the warm air into the interior more easily.

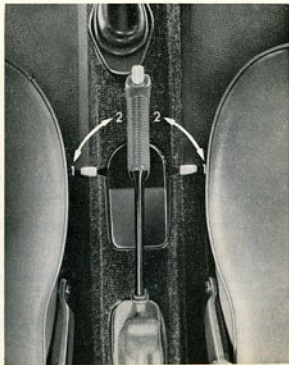

Never attempt to influence the cooling and heating of your car in winter by covering the air intake slots in the rear hood. These slots must always remain open to ensure the flow of fresh air to the carburetors and fan.

Engine oil SAE 30 oil will tend to thicken at temperatures below freezing point and result in difficult starting. Change over to a thinner engine oil SAE 10 W or a multigrade oil SAE 10 W-30 at oil changes when temperatures under freezing point are expected.

In territories where exceptionally low temperatures prevail (below -25°C -13°F), the use of SAE 5 W engine oil is recommended. The oil should be changed every 1250 km (750 miles).

The SAE 90 transmission oil can generally be used all the year round. It need only be replaced by the thinner SAE 80 grade in countries with arctic climates.

The chassis is naturally exposed to very severe conditions in the winter. The steadily increasing use of chemicals to de-ice the roads produces solutions which attack even the most durable paintwork after a time. The underside of your Volkswagen is sprayed with a wax-based compound to protect it from these influences. It is advisable to examine the protective film at the beginning of the winter and have it repaired by respraying so that the full protective effect is retained.

The Battery requires particular maintenance in winter because of the increased consumption of current when starting the engine and using the lights at night. Furthermore, its efficiency decreases at lower temperatures. If the car is mostly used over short distance or in city traffic, it is advisable to have the battery recharged occasionally. The connections between battery and starting motor must be kept perfectly clean.

The Spark Plugs should not have an excessively large gap especially in winter. The normal spark plug gap is 0.7 mm (.028"). In extremely cold weather the gap can be reduced to between 0.4 and 0.5 mm (.016" and .020") to facilitate starting.

The brakes are considerably exposed to splash water and condensation which in winter is apt to freeze in the brake drums. Therefore, when parking your car, do not set the handbrake, but shift to first or to reverse gear.

The door locks can freeze up in winter, especially if water gets into the lock cylinders when washing the car. Do not aim the water jet directly at the locks, but instead, cover up the key holes when washing. The frozen lock can be opened by warming the key before insertion and then squirting anti-freeze into the lock cylinder straight away.

Tires with badly worn treads are very dangerous particularly in the winter so ensure that they are replaced in good time.

M+S tires with special heavy treads give good road holding in snow and slush. They can be fitted to all four wheels. M+S tires should however, never be fitted on the front wheels only. Better still are the M+S ice tires (spiked) which increase the safety margin even on hard snow and ice. Even with these tires, which should always be fitted to all four wheels, you should not allow yourself to be misled into driving faster than you would under the same conditions with normal M+S tires.

In general, special winter tires only have real advantages when conditions on the roads are really wintry. For safety reasons, it is not advisable to drive a vehicle fitted with any type of winter tire at top speed. You cannot expect a winter tire to have the same degree of adhesion on dry snow free roads as a normal tire. Furthermore, under these conditions M+S tires wear rapidly, particularly at high speeds.

Clips must be fitted on the lower torsion arms when using M+S or spiked tires in order to prevent the tires from rubbing on the wheel housings on full lock.

Snow chains, in conjunction with normal and winter tires, can only be used on the rear wheels. Only thin chains which do not stand clear of the tire tread and walls more than 15 mm, including tensioner, are suitable. When driving over long stretches of road which are free of snow the chains should be removed. They serve no useful purpose here and merely damage the tires and wear out quickly.

Care of the Tires

Apart from the tire pressures, your driving habits also affect the tire wear considerably. Rapid acceleration, violent braking and cornering result in more excessive tire wear as compared to careful driving.

Avoid overloading the car and protect the tires from intense sunlight, fuel or oil.

The tires should be checked occasionally for foreign matter and damage. The tire tread should never be allowed to wear down to a thickness of less than 1 mm (.04") which is the absolute minimum required for safe usage. If the tires show signs of uneven wear after a considerable mileage consult your local VW dealer.

For smooth running at high speeds and long tire life, it is important to have the wheels balanced statically and dynamically. As the wheels can be out of balance owing to natural wear of the tires, they should be balanced every 10,000 km (6,000 miles).

When mounting the tires, the red mark should be positioned at the valve.

Changing Wheels

The spare wheel, jack and tools are found under the front hood which is opened by means of the knob under the instrument panel. The jack is secured in the spare wheel well by means of a clip. The partition between spare wheel well and luggage compartment can be pushed to the rear when removing the spare wheel and jack.

Set the hand brake.

Take off the wheel cap with the removal tool and loosen all five wheel bolts about one turn with the wrench and operating bar.

Insert the jack in the square tube below the sill panel and push down the jack base plate until it makes contact with the ground.

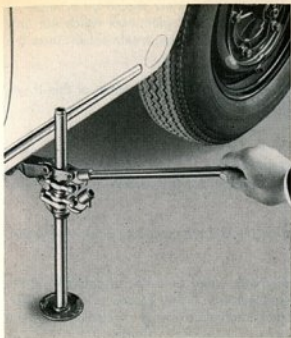

Insert operating bar in upper link of jack and lift vehicle until wheel is clear of ground.

Remove wheel bolts and take off the wheel.

Raise the car until the five holes in the wheel are roughly lined up with the holes in the brake drum.



Insert one wheel bolt and tighten it to such degree as to allow the wheel to be swung round this point by hand until the remaining holes in the wheel and brake drum coincide.

Insert other wheel bolts.

First tighten the screws until the wheel, centered by the spherical shape of the

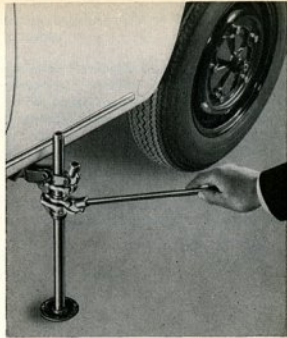

screw heads, contacts the brake drum evenly.

Insert operating bar in the lower link of the jack and lower the vehicle.

Tighten the wheel bolts evenly.

Place trim ring in wheel and install wheel cap with a smart blow with the hand.

Care of the Car

Clean and smart appearance. To keep the car looking smart and new should be a matter of pride to the driver or owner. It is our object to provide you with paintwork which not only looks good and has a sparkling lustre but is most durable. A chemical treatment protects the body against rust and anchors the synthetic resin enamel to the metal.

Even the best paint work requires regular care. You will realise the importance of this if you consider that the paint is exposed to sunshine, rain, dust and dirt.

Wash your new car frequently during the first weeks as this is good for the finish. When washing you require a soft sponge for the body, a soft brush for the wheels, a sturdy, long-handled brush for the chassis, and plenty of water.

The chassis and lower part of the body should first be flushed with water to soak off the dirt, and afterwards a brush should be used.

Spray the exterior finish of body and wheels evenly with water until dirt is soaked off. Do not allow a powerful jet of water to hit the painted surface. Using plenty of clean water, remove dirt with a sponge. Clean the sponge at short intervals to avoid scratching the paint work.

There are many proven auto soaps and detergents available which greatly facilitate this job. Do not buy just any product, let your VW dealer advise you. It is of utmost importance to rinse the body thoroughly with water to ensure that no traces of the detergent remain on the body. After washing dry off with a clean chamois to prevent water spots from forming.

Preservation (Waxing) should be carried out for the first time after approximately 8 to 10 weeks and afterwards, if possible, at regular intervals of between 6 and 8 weeks. Waxing means to restore to the finish certain substances it has lost by exposure to the weather. At the same time a protective water-repellent coat of wax applied to the body.

The "Genuine VW Preservative" (L 190) was specially produced for the Volkswagen and is obtainable from every VW dealer. After washing and rubbing down the car thoroughly, apply the preservative thinly with a soft cloth. Let it dry for approximately 20 minutes and then rub it down with polishing cotton or a soft polishing cloth until iridescent colours can no longer be seen when you are standing at an angle to the polished area.

Do not forget to wax the car after each detergent washing as the intensive cleansing properties of the chemical detergent will partially dissolve the protective film of wax.

Polishing. You should polish your car only if its appearance has been affected as a result of insufficient care, or if the application of the preservative no longer restores the original lustre. Avoid the use of abrasives or chemically harmful products.

A special polish for the synthetic-resin enamel finish is also available from your Volkswagen dealer under the designation "Genuine VW Polishing Fluid" (L 170). Prior to applying the polish, the car must be washed and dried carefully. The polish should be applied with a soft clean cloth or polishing cotton — use a straight horizontal or vertical motion rather than a circular motion. After rubbing for some time you will notice a slight resistance, which indicates that the ingredients of the polish have settled in the finish and that the solvent has evaporated. Now take clean polishing cotton and rub the body down until the high polish is restored.

To prevent the polishing fluid from drying off prematurely, do not apply it on too large an area of the body at a time. A subsequent application of the preservative and your efforts will be rewarded with a long-lasting shine.

Never wash, wax or polish the car in sunlight.

Tar spots. Tar splashes have a tendency to corrode the finish within a short time and should be removed as soon as possible with Genuine VW Preservative.

On the road you usually have nothing at your disposal but fuel. Kerosene or turpentine may also be used. After this, the treated spots should be washed with a mild, luke warm detergent solution, and rinsed, in order to remove traces of the cleansing agent.

Insects are caught especially in hot weather on the front of the car and on the windshield. Insects should not be allowed to remain on the paint finish for long and should be removed with water and a sponge. Once baked on they can only be removed with luke warm detergent solution.

Parking under Trees. Vehicles which are parked under trees for long periods in summer are often found to be covered with spots. These spots can be removed fairly easily with luke warm detergent solution if the treatment is not delayed too long. It is advisable to apply a coat of preservative afterwards.

Chrome Parts should be treated with "Genuine VW Chrome Cleaner Chromlin" when dry. Apply Chromlin thinly and allow to dry for 10 minutes before polishing with a dry cloth.

Cloth upholstery. If a vacuum cleaner is not available, the upholstery should be cleaned thoroughly with a brush or whisk broom. Stains can generally be removed with luke warm detergent solutions. Grease and oil stains are removed with cleaning paste or cleaning fluid. Do not pour the cleaning fluid directly on the upholstery as otherwise rings will form. Moisten a clean, uncoloured cloth with the fluid and rub with a circular motion, starting outside the spot and working inwards.

Leatherette can best be cleaned with a soft cloth or soft brush. If very dirty, a luke-warm soap solution or a dry foam cleaner can be used.

Grease and paint spots should be wiped off before they dry up. Soaked-in spots can be removed by rubbing carefully with a cloth moistened with benzine or methylated spirits. Spots caused by shoe polish can be removed with turpentine. Use these agents carefully and sparingly as otherwise they tend to dissolve the dust-repellent finish of the leatherette. Solvents such as trichlorethylene or paint thinner must not be used for cleaning. After cleaning, the leatherette should be dried thoroughly with a soft cloth. So-called preservatives are not suitable for leatherette because they do not soak into the material and merely collect dust and make clothing dirty.

The windows can be cleaned best with a clean sponge and warm water. A glass cleaning solution should only be added to the water in exceptional cases as these solutions tend to affect the paint preservative. Always use a special clean leather to dry the windows. This leather must not be used for the paintwork in any circumstances as most paint cleaners and polishes contain ingredients which will cause unpleasant streaks to appear on the windshield when it rains, even if only the smallest trace is present.

These streaks can only be removed with a good windshield cleaner and a lot of care. Do not forget the windshield wiper blades.

Door and window weatherstrips. It is important to keep the rubber parts undamaged and supple to ensure perfect sealing. To retain the original flexibility of the rubber, these parts should be coated occasionally with talcum powder.

Airing the interior. If the car is left in your garage for a long period, it must be aired regularly. Permit air to circulate freely by opening the doors or lowering the windows thus preventing the formation of mould and damp stains.

Lubrication Service

To lubricate correctly means to lubricate carefully and at the prescribed intervals. Therefore, do not omit to have lubrication service carried out at regular intervals. A lubrication chart can be found on page 59 indicating the correct mileages at which to lubricate.

The Service Booklet makes it possible for you to have your car lubricated at our authorized workshops by skilled personnel, at lowest cost and in a minimum of time. You really cannot afford to miss this opportunity.

Engine

Regular oil changes are necessary even if the very best branded oils are used. Dirty oil in your engine simply means increased wear and a shorter service life.

The oil is drained, when warm, by removing the plug in the oil strainer bottom plate. Flushing of the engine is unnecessary. However, the oil strainer must be removed and cleaned at every oil change. The two gaskets and the washers under the cap nuts must be renewed each time. The engine is refilled with 2.5 liters of HD oil (5.3 US pints/4.4 Imp. pints).

Draining the engine oil.

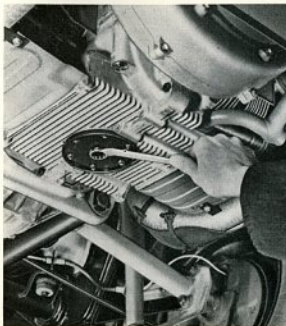

Cleaning the oil strainer.



It is superfluous and uneconomical under normal operating conditions to change the oil at shorter intervals than every 5000 km (3000 miles). We recommend oil changes at more regular periods, i. e. at intervals of 2500 km (1500 miles) only if you do not drive much in winter and in doing so mostly cover short distances in city traffic.

Types of lubricant

HD oils are prescribed for the engine lubrication. HD oil is an oil having proven oxidation stability, bearing corrosion preventive properties and detergent-dispersant characteristics which tend to hold in suspension foreign contaminants which would normally deposit on engine parts. These foreign contaminants will drain out with the oil at the periodical oil changes. The detergent properties of HD oil will make the fresh oil darker after a short time of operation. This is quite natural and there is no reason whatsoever to change the oil earlier than called for in the Lubrication Chart.

Some more Information on Oils

The quality of branded oils is such that the choice is left to your discretion. In cases of doubt, your authorized VW dealer will be glad to assist you. We recommend that you select "your" oil after the first 500 km (300 miles) and stick to it at all future oil changes.

Viscosity of the lubricant is an indication of its resistance to flow at a given temperature. The SAE numbers for instance SAE 30, SAE 10 W etc. classify lubricants in terms of viscosity. The outer temperature is decisive when selecting the viscosity.

SAE 30 is satisfactory for all temperatures above 0° C (32° F).

SAE 10 W should always be used in the cold season if the temperature is expected to fall below 0° C (32° F) by the next oil change.

SAE 5 W is for use in arctic climates below —25° C (—13° F) only.

30 **SAE 10 W-30** is a multigrade oil and can be used in summer and winter.

Temporary deviations in the temperatures for the various viscosity grades are of no importance. It is permissible to mix oils of different viscosity grades when it is necessary to add oil between the oil changes, and the outer temperature no longer corresponds to the viscosity grade of the oil in the engine. It is, however, essential that the same brand of oil be used.

In some countries the API classification is applied (API = American Petroleum Institute). According to this classification, the HD oils suitable for the VW engine are referred to as "For Service MS".

No additives of any kind should be mixed with HD oils.

Transmission

The transmission and differential gears are combined in the transmission case and both lubricated with hypoid oil. The oil should be up to the edge of the filler hole. At oil changes — at 500 km (300 miles), 5,000 km (3,000 miles) and then again at 50,000 km (30,000 miles) — the old oil is drained by removing both the magnetic drain plugs while the oil is at operating temperature. The magnetic oil drain plugs should be cleaned thoroughly and the transmission then filled with 2.5 litres (5.3 US pints/4.4 Imp. pints) of branded hypoid oil.

Additives should not be used with hypoid oil.

Draining the transmission oil.

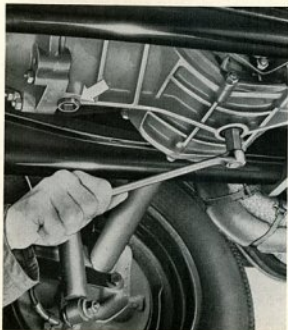

Filling with transmission oil.

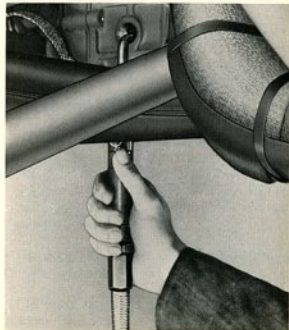

Chassis

Proper lubrication of the front axle bearing points can best be ensured by raising the front axle so that the weight is taken off the wheels.

The front axle has four grease fittings which must be lubricated every 10 000 km (6000 miles).

Prior to lubrication, the grease fittings should be cleaned thoroughly with a cloth to prevent dirt from being forced into the bearings.

The dust seals of the maintenance-free ball joints must be checked for damage and security at every lubrication service.

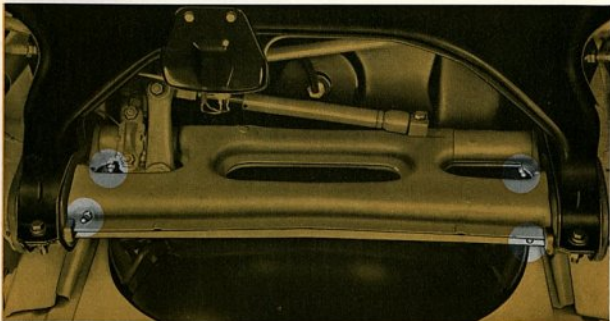

Damaged seals should be replaced immediately if possible.

Oil and grease should be kept off the tires and brake hoses. Even small quantities should be wiped off immediately.

If you drive less than 10,000 km (6000 miles) in the year, we suggest that the front axle is lubricated once a year.

Annually at the beginning of the cold season the cables for the accelerator, clutch and heating as well as the clutch cable adjusting nut should be checked and, if necessary, cleaned and lubricated.

The Front Wheel Bearings

are packed with grease on assembly. The caps on the front wheels hubs must be free from grease.

Every 50,000 km (30,000 miles) the bearings should be carefully cleaned and packed with the grease prescribed under "Lubricants".

The brake drums must be removed for this purpose. Finally the front wheel bearings must be adjusted. In order to avoid damage to the bearings, this operation should, if possible, be carried out in a VW workshop only.

Doors and Hoods

The door hinges require no maintenance.

The door lock cylinders are lubricated with graphite. It is sufficient to dip the key into the graphite and to move it back and forth several times in the lock.

The door lock striker plates should be very lightly greased.

The hood hinges are oiled, the hood locks lightly greased.

Maintenance Service

The Volkswagen Service Organisation has made available for you an extensive network of authorised VW workshops staffed with well trained and experienced personnel, and equipped with all the special tools required for servicing your car. If ever you should need service when touring and away from home, look for the well-known VW Service Sign. Here you will receive prompt and expert advice.

In case you can't get to an authorised VW workshop in time, we are giving you some information which, if needed, will help you to carry out normal maintenance work. However, it is important that repair jobs which are beyond your capacity should be performed by the nearest VW workshop. Your car is then in capable hands. This will save you time, inconvenience, and money.

Checking the V-belt

The belt should be checked at regular intervals for tension and wear. When pressed with the thumb it should yield approximately 1.5 cm (.6") and should not show signs of excessive wear.

The intake housing cover is removed when adjusting or replacing the belt. Now loosen the nut on the generator pulley with a 21 and 27 mm wrench and remove the rear half of the generator pulley. The belt tension is adjusting by removing or inserting spacer washers between the two pulley halves. Removing spacer washers increases the tension and inserting washers reduces it. The belt should not be too slack, nor should it be too tight.

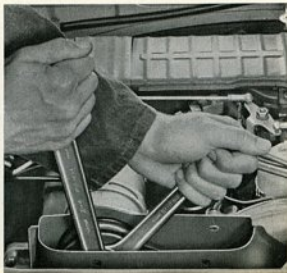

Checking Air Cleaner

The oil bath air cleaner should be checked every 5000 km (3000 miles).

All the dust present in the air drawn in by the engine is retained by the filter in the upper part of the air cleaner and washed out when the vehicle is in motion by the oil in the lower part of the cleaner. In time, this causes a layer of sludge to form at the bottom of the lower part. If the cleaner check reveals that there is only 4—5 mm (.16"—.2") of oil above the sludge layer, the lower part should be carefully cleaned and filled with fresh oil. The top part does not need cleaning. However, if the filter insert has become so dirty due to delayed cleaning of the lower part or oil shortage that the air inlet holes on the underside are partly, the encrusted dirt should be removed, preferably with a chip of wood.

A dirty filter insert not only reduces the engine output, it can also cause premature wear in the engine. If the local conditions are such that the vehicle is frequently driven over very dusty roads it is advisable to clean the air cleaner more often.

The warm air control flap should be checked each time for freedom of movement. This flap regulates the flow of pre-heated air to the carburetor in conjunction with the speed of the engine.

Servicing Air Cleaner

Take off connecting rod between three-arm lever and right-hand carburetor.

Disconnect automatic choke cable from right-hand carburetor and from ignition coil.

Take ignition cable off coil.

Pull crankcase breather hose off cleaner intake.

Loosen securing clip on air cleaner intake and pull bellows off intake tube.

Remove center wing nuts securing the cleaner.

Loosen right and left wing nuts until the cleaner can be taken out.

Take cleaner out and take upper part off after loosening the five clips. Never lay the upper part down with the filter element upwards.

Clean lower part of cleaner thoroughly. The water drain hole must always be clear.

Fill lower part up to the mark with fresh SAE 20 engine oil.

Align the marks on the upper and lower parts when assembling the cleaner. On installation, ensure that the rubber seals between cleaner and carburetors are located properly and that the bellows on the cleaner intake seals correctly. Furthermore it is essential to tighten the two outer wing nuts securing the filter first and then the center one.

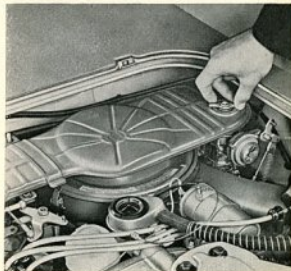

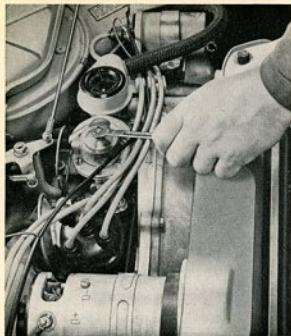

Cleaning the fuel pump filter

The fuel pump filter prevents foreign matter and water from entering the carburetor. It should be removed and cleaned at the prescribed intervals. Install clip on fuel hose in engine compartment.

Remove lock ring for the fuel pump protection cap.

Remove left half of the protection cap.

Remove retaining screw and take off cover. Take out filter and wash out in benzine.

When installing the filter do not omit the gasket for the cover.

Ignition timing

Particular attention must be paid to correct ignition timing. In many cases poor performance, high fuel consumption and even damage to the engine can be the result of incorrect ignition setting. The ignition must not be advanced arbitrarily.

Before setting the ignition timing the breaker contact point gap must be checked. With the breaker arm fully lifted the clearance should be 0.4 mm (0.16"). The initial spark advance must be set to 10° before top dead centre.

The ignition timing must only be set with the engine cold or when it is slightly warm.

Cleaning Contact Points

The contacts points must be smooth and make even contact with each other. Dirty contacts should be cleaned, and if pitted, smoothed with a contact file. Whilst doing this, the contact points should be pressed lightly together. Afterwards the ignition distributor should be blown out carefully with compressed air. If the points are badly burnt they must be replaced.

Lubricating Ignition Distributor

The breaker arm fiber block in the ignition distributor should always be greased lightly with lithium grease. Every 5000 km (3000 miles) check whether this location must be cleaned and provided with new grease. Only a very small amount of grease should be used and none of it must come in contact with the breaker points as otherwise the ignition will be affected.

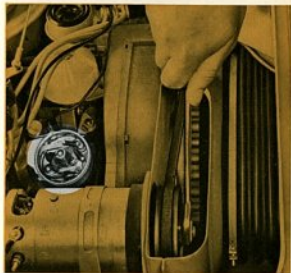

Adjusting Contact Points

Remove distributor cap and rotor.

Remove air intake housing cover and turn the engine by means of the generator until the contact arm rests on the highest point of the cam lobe.

Loosen the breaker point locking screw.

Insert a screwdriver between the two lugs on the contact plate and the slot in the point carrier and adjust the gap to 0.4 mm (.16").

Tighten locking screw and install rotor.

After the contact points have been adjusted, the ignition timing must be reset.

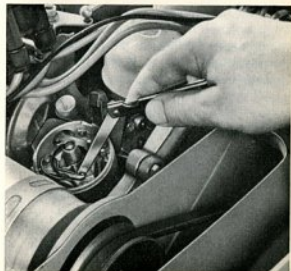

Setting the ignition timing



Turn the engine clockwise until the center mark on the crankshaft pulley lines up with the adjusting surface on the fan housing and the distributor rotor arm is in line with the number 1 cylinder mark on rim of distributor.

Loosen clamp screw on distributor retainer.

Connect a 6 Volt test lamp to terminal 1 of the ignition coil and to ground.

Switch on ignition.

Rotate the distributor clockwise until the contacts points are closed and then slowly

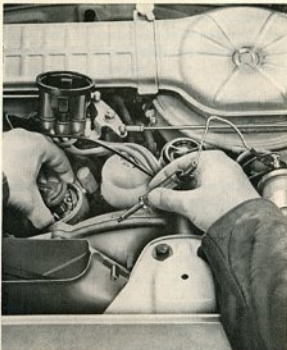

anti-clockwise until the contact points just start to open and the test lamp comes on.

Tighten the clamping screw of distributor retainer.

Install distributor cap.

The ignition is correctly set if on turning the engine over slowly clockwise, the test lamp comes on when the center mark on the crankshaft pulley is in line with the adjusting surface on the fan housing. Beforehand, the engine should be turned back anti-clockwise approximately a quarter of a revolution to take up the play in the distributor drive.

Checking the Spark Plugs

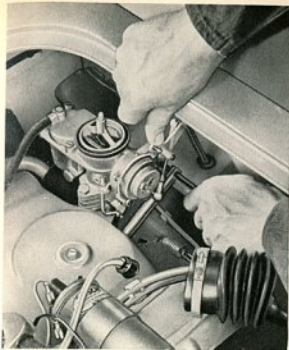

The appearance of the electrodes and insulation gives valuable information on the adjustment and condition of the engine:

- | | |
|-------------|--|
| medium grey | — correct carburetor adjustment and proper performance of spark plug |
| black | — mixture too rich |
| light grey | — mixture too lean |
| oiled up | — failure of spark plug or piston ring blow-by |

The spark plugs have an average service life of approximately 15,000 km (9000 miles) and should, therefore, be replaced in time. To

prevent any breakdowns in the ignition system, the spark plugs should be checked every 5000 km (3000 miles). The air cleaner must be taken off to remove the spark plugs. It is also advisable to unhook the return springs from the carburetor pull rods.

Deposits can easily be removed with a brush and a chip of wood. Moreover, the insulator should be clean and dry on the outside in order to avoid short circuit and tracking. If necessary, adjust the spark plug gap to 0.7 mm (.028").

Do not omit the gasket when screwing in the spark plug. Do not overtighten the spark plugs.

Checking the compression

The compression is checked by inserting a suitable gauge into the spark plug hole when the engine is warm. All the spark plugs should be removed and the air cleaner taken off. The accelerator pedal is then depressed fully and the engine turned over with the starter until the gauge reading shows no further change.

The pressure should be at least 8 kg/cm² (114 psi.). It is important that only a good accurate instrument is used and a good seal obtained between instrument and spark plug seat.

Adjusting the Valves

The valves must only be adjusted when the engine is cold or slightly warm. The valve clearance for the intake valves is 0.20 mm (.008") and for the exhaust valves it is 0.30 mm (.012").

When adjusting, both valves must be closed, i. e. the piston of the corresponding cylinder must be at T.D.C. of the compression stroke. The arrangement of the cylinders can be seen by the numbers 1 to 4 on the engine cover plates. Valve adjustment is carried out in the following sequence: cylinders 1, 2, 3, 4.

Remove intake housing cover.

Remove distributor cap.

Turn the engine until the rotor arm points to the No. 1 cylinder mark on the rim of the distributor.

Remove cylinder head cover.

Loosen the adjusting screw lock nuts for the valves of No. 1 cylinder.

Adjust valve clearance with a feeler gauge.

Hold the adjusting screws and tighten the lock nuts.

To adjust the valves for cylinders No. 2, 3 and 4, the engine is turned **anti-clockwise** until the rotor arm is 90° offset each time.

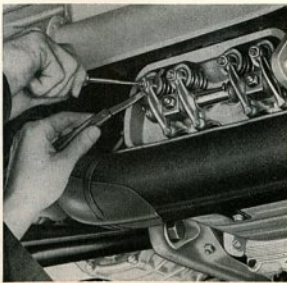
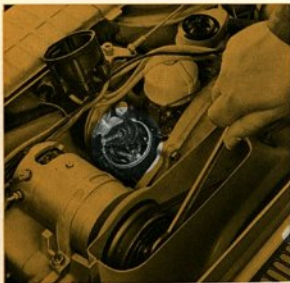

Carburetor Adjustment

The carburetors are checked at the factory and set exactly on the engine. The alteration of the setting by fitting jets or choke tubes of other than the specified sizes is detrimental and should not be done. Checking and adjusting the carburetor requires special test equipment in addition to knowledge and experience. For this reason, it is advisable to leave work of this nature to a VW Service Station.

Special test appliances are also required for the idling adjustment. However, if you are compelled to correct the setting yourself anytime, proceed as detailed below. The adjustment should then always be checked accurately in a VW Service Station at the first opportunity.

Run engine till warm.

Take off right-hand connecting rod between three-arm lever and carburetor.

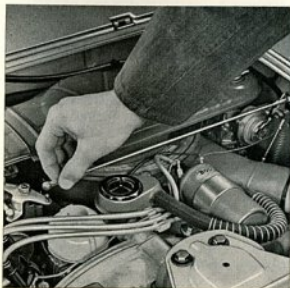

Turn idling adjusting screws (1) on both carburetors back so far that throttle valves are fully closed, then turn screws in again until they just touch the throttle valve levers and finally give them both one half turn inwards.

Turn the volume control screw (2) of one carburetor clockwise until the engine speed begins to drop. Then give screw one quarter of a turn in an anti-clockwise direction.

Adjust the volume control screw of the other carburetor in the same manner.

Regulate the idling speed to about 750 rpm by adjusting the idling adjustment screws uniformly on both carburetors.

Install the connecting rod between carburetor and a three-arm lever free of tension. If necessary, the length of the rod must be rectified after loosening the two locknuts.

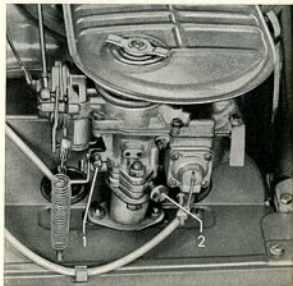

Checking Clutch Pedal Free-Play

Easy gear shifting and complete transmission of engine performance to gears and wheels can only be guaranteed if the clutch is adjusted as specified.

Measured at the clutch pedal, this free-play should be between 10 and 20 mm / .4 and .8 in. (a). The clearance is adjusted by an adjusting nut on the cable end.

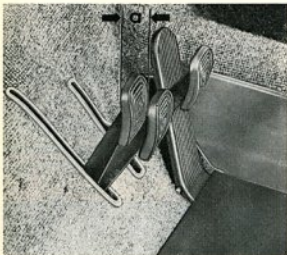

Release lock nut on the threaded cable end. Adjust free-play by turning the nut.

Depress clutch pedal several times and re-check pedal free-play.

Hold adjusting nut and tighten lock nut.

Lubricate bearing point between operating lever and adjusting nut with universal grease.

Adjusting Front Wheel Bearings

Raise front of car.

Bend up lock plates and loosen nuts. The nuts of the left front wheel have left-hand threads.

Remove outer nut and insert a new lock plate.

Rotate wheel and tighten inner nut until the thrust washer between bearing and nut can

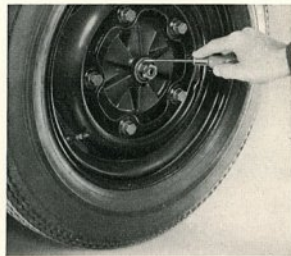

be moved easily with a screwdriver without turning or levering movements when the lock nut is fully tightened.

It should be just possible to rock the wheel when the bearings are adjusted properly.

Bend up the lock plate alternately.

Adjustment operations on the front wheel bearings should, if possible, be carried out in a VW workshop only. Incorrect adjustment of the bearings can cause severe damage in a short time.

Checking Play of Upper Torsion Arms

The upper torsion arms of the front axle are connected by the stabilizer and normally have hardly any noticeable axial play in their bearings. In the course of time, this play will increase and must, therefore, be checked at the prescribed intervals, that is, every 5000 km (3000 miles).

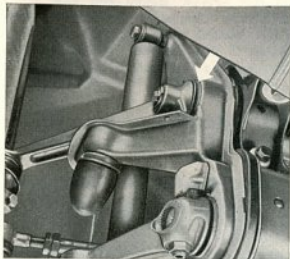

To check the play, rock one wheel and observe the torsion arms. If play is noticed at the upper torsion arms, they must be re-adjusted. This operation should be left to a VW workshop, as the camber and the toe-in of the front wheels have to be corrected afterwards. These operations require special experience and measuring devices which will be found in every workshop.

The Camber and Toe-in of the Front Wheels

can only be reliably checked in a workshop. When the car is unladen, the camber should be $1^{\circ} 20' \pm 10'$, the toe-in 4 to 6 mm (.16" to .24"). Inadmissible deviations from these values will have a detrimental effect on roadholding and tire wear.

The Steering

The steering must be free of excessive play in the straight ahead position. Moreover, the wheels must self-center after cornering.

To check the steering move the steering wheel to and fro until resistance is felt. The adjustment is correct if the to and fro movement does not exceed 25 mm/1", measured at the steering wheel rim.

Adjustments to the steering require special experience as well as special tools, and these operations should only be carried out in a VW workshop.

Checking and Adjusting Brakes

As a result of natural wear, the clearance between brake shoes and drum will increase during the course of time. If the foot brake pedal travel becomes excessive, the brakes must be relined or re-adjusted.

The brake lining wear must be checked every 5000 km (3000 miles). The brake lining thickness must not be less than 2.5 mm (.1"). Moreover, check the brake system for damage, leaks and corrosion. Damaged brake lines must be replaced immediately.

Spongy brake pedal travel indicates the presence of air in the system. Before bleeding the brakes, check the brake fluid level in the reservoir beside the spare wheel. To do this, the spare wheel compartment panel

can be folded back. The reservoir should be at least three quarters full. Only use Genuine VW Brake Fluid or Lockheed Brake Fluid when topping up.

Handle the brake fluid carefully. It will damage the paint work severely.

Adjusting the Foot Brake

The brake shoes are adjusted individually on all four wheels. Before and after brake adjustment completely depress the brake pedal several times to allow the brake shoes to centralize in the drums. When adjusting the rear brakes, the hand brake must be released.

Remove wheel cap.

Jack up a wheel and turn it until the hole in the brake drum is in line with one of the two adjusting nuts.

Turn the adjusting nut with a screwdriver in the direction indicated by the arrow until a slight drag is noted when wheel is turned by hand.

Repeat procedure on the other adjusting nut. Note that the two nuts turn in opposite direction.

Back off the adjusting nuts 3 to 4 teeth until the wheel rotates freely.

Install wheel cap and make sure that it is correctly seated.

Repeat the above operations on the other wheels.

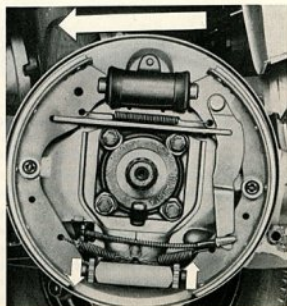
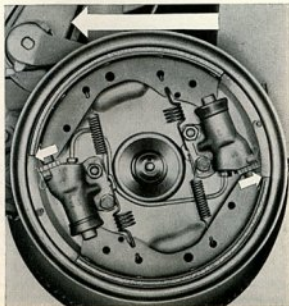

Bleeding the Brakes

When bleeding the brakes, always begin with the wheel which is farthest away from the master brake cylinder. The sequence for cars with left-hand drive is as follows: Right and left rear wheels, then the right front and finally the left front wheel.

Remove rubber cap of the bleeder valve and attach bleeder hose.

Submerge the free end of the hose in a glass container partially filled with brake fluid. The end of the drain hose should, if possible, be above the level of the bleeder valve.

Slacken the bleeder valve between $\frac{1}{2}$ and 1 turn using a 7 mm wrench (rear) and 11 mm (front).

Pump the brake pedal several times until the air bubbles cease to appear.

Keep the brake pedal in the fully depressed position, until the bleeder valve is closed.

Remove the bleeder hose and replace rubber cap.

Repeat the above operations on the other wheels. Make sure that the brake fluid level in the reservoir is sufficient to ensure that air is not drawn in. After bleeding the complete system, check the brake fluid level and top up if necessary.



Adjusting Hand Brake

The hand brake is adjusted at the hand brake lever:

Raise both rear wheels.

Slide back rubber ring and fold back hand brake lever rubber boot.

Back off lock nuts and tighten the adjusting nuts until the rear wheels are just free to turn when the hand brake is released.

Pull up the hand brake lever by two notches and make sure both the rear wheels have the same braking effect. At the fourth notch it should be impossible to turn the wheels by hand.

Lock the adjusting nuts and slide the rubber ring over the hand brake lever boot.

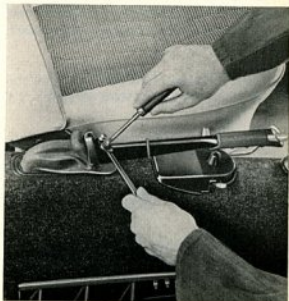

Checking the Battery

Ready starting of the engine depends upon the condition of the battery. It should, therefore, be checked and maintained regularly. The battery cover can be removed by raising the rear seat and releasing the battery strap.

The acid level must always be slightly above the plates. The acid level has to be adjusted in accordance with the acid level mark. Depending on the type of battery, either the lower edge of the insert or the bar above the plates must just be covered. Losses by evaporation can be replenished by adding distilled water. Do not add acid unless some of the electrolyte has been spilled. The acid can boil over and cause damage. For this reason exercise care when topping up.

The battery should be checked with a cell tester. This is a voltmeter in parallel with a heavy resistance. The voltage of each cell should not fall below 1.6 Volts while the reading is being taken (10—15 seconds). Otherwise the cell is discharged or defective. The normal voltage is 2 Volts.

The battery poles should be cleaned with a clean cloth, or in the event of heavy corrosion, with a stiff brush. The battery poles and cable terminals should be provided with grease. Make sure that the battery is correctly grounded.

The state of charge of the battery can be checked with a hydrometer. The specific gravity of the acid will increase with the charging of the battery. The specific gravity can be read from a scale.

Battery fully charged	1.285 s. g. or 32° Bé
Battery semi-charged	1.230 s. g. or 27° Bé
Battery discharged	1.142 s. g. or 18° Bé

When laying your vehicle up for a prolonged period, it is advisable to take the battery to a workshop for storage. A battery which is not in constant use will discharge itself in time and this can result in permanent damage to the plates if the battery is not checked about every



- a — the height of the headlight center from the floor
- b — 50 mm (2") — adjusting line for the headlights
- c — 1258 mm (49.5") — distance between headlights
- d — the height of the fog lamp center from the floor
- e — 270 mm (10.6") — adjusting line for the fog lamps



Aiming the Headlights and Fog Lamps

If a headlight aiming device is not available, proceed as follows:

Position the vehicle on level ground 5 m (16 ft. 5 in.) in front of a dark wall which will serve as a screen. The tire pressures must be correct. The rear seat must be loaded with one person or a weight of 70 kg (154 lbs.).

Draw crosses on the wall as shown in the sketch. The longitudinal center line of the vehicle must be aligned exactly between the two crosses on the screen.

Remove securing screw in the center below the headlight and take off trim ring.

Aim the headlights individually by turning the two slotted screws with the beams dimmed. Cover up the second headlight.

A — Horizontal

B — Vertical

The headlights are correctly aimed when the light-dark border line is horizontal on the adjusting line to the left of the cross and the angle on light-dark border line is exactly on the center of the cross.

Aim the fog lamps by means of the adjusting screws from inside the spare wheel well so that the center of the light beam is exactly on the adjusting line.

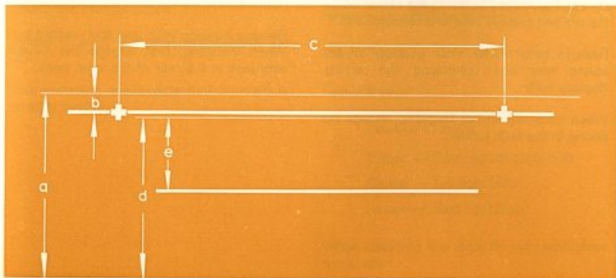



Headlight Bulb Replacement

Remove Phillips screw in the center below the headlight and take off trim ring.

Remove securing screw for lens and reflector unit and take off lens and reflector unit. Turn the cap to the left and take the holder out of the reflector.

Pull the connector off the bulb base and replace the bulb.

Never touch the bulb with the bare hand, but only with a clean cloth or a paper serviette etc. The lug in the lamp holder must engage in the notch provided in the reflector.

Insert the cap so that the contact strip is located on the base of the parking light bulb.

Check headlight adjustment.



Fog Lamp Bulb Replacement

Loosen the Phillips screw in the center below the rim and remove lens and reflector unit.

Remove bulb holder after pushing off the spring clip and unhooking the spring. Replace bulb.

When installing do not forget to engage the spring in the bulb holder.

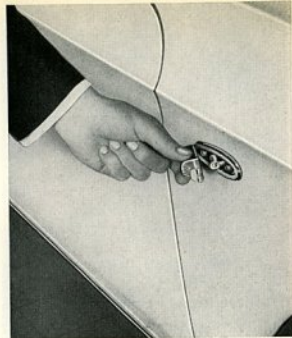

Parking Lamp Bulb Replacement

Remove Phillips screw.

Remove housing with lens and replace bulb. When installing, first engage the housing with lens in the rear of the lamp base.

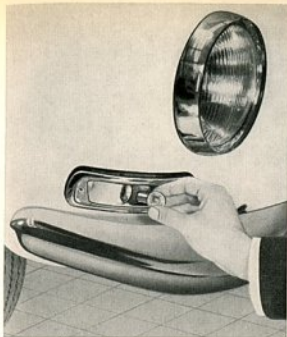

Front Flashing Indicator Bulb Replacement

Remove the Phillips screw.

Remove housing with lens and replace the bulb.

When installing, make sure that the seal is correctly seated.



Stop/Flashing Indicator or Tail Light Bulb Replacement

Remove two Phillips screws.

Take off lens.

Replace bulb.

Position of bulbs:

Upper — Flashing indicator bulb

Center — Tail light bulb

Lower — Stop light bulb

When installing the lens, do not overtighten the screws.



Licence Plate Light Bulb Replacement

Remove the two Phillips screws and take off chrome frame with lens.

Take the bulb holder out of the overrider and replace bulb.

When installing make sure that the rubber seal is correctly seated.

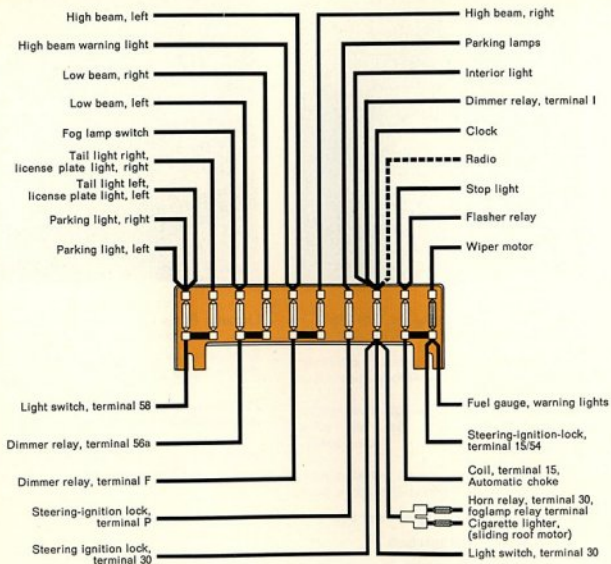

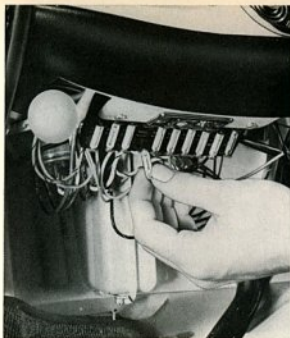

Replacing Fuses

The fuse box is located to the left under the instrument panel. Two additional fuses for the cigarette lighter, horns and fog lamps are provided in the cables behind the instrument panel. When a fuse has blown, it is not sufficient merely to replace it by a new one. Inspect the electrical system for evidence of short circuits or other faults.

Under no circumstances use fuses which have been patched with tin foil or wire as they would be liable to cause severe damage elsewhere in the electrical system. We suggest that you always carry a few fuses: 16 Amp. fuses for the horns, fog lamps, windshield wiper motor and cigarette lighter and 8 Amp. fuses for all the other electrical fittings.



Adjusting Doors

There should be no noticeable play between the lock and the striker plate. It must be possible to open the doors easily without any signs of their jamming. To adjust the door, loosen the three striker plate screws at the lock pillar and move the striker plate. Adjust the striker plate so that door and pillars are a flush fit. The striker plate is correctly adjusted if the housing on the door has the same clearance at top and bottom when sliding into the striker plate.

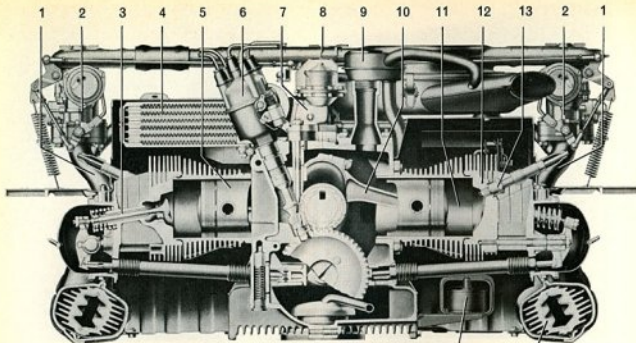

- 1 - Intake manifold
- 2 - Carburetor
- 3 - Valve
- 4 - Oil cooler
- 5 - Piston
- 6 - Ignition distributor
- 7 - Fuel pump
- 8 - Oil bath air cleaner
- 9 - Crankcase breather
- 10 - Connecting rod
- 11 - Cylinder
- 12 - Cylinder head
- 13 - Spark plug
- 14 - Flywheel
- 15 - Camshaft
- 16 - Oil strainer
- 17 - Crankshaft
- 18 - Camshaft drive gears
- 19 - Oil pump
- 20 - Fan
- 21 - Fan housing
- 22 - Crankshaft pulley
- 23 - Muffler
- 24 - Cooling air intake housing
- 25 - Ignition coil
- 26 - Heat exchanger
- 27 - Thermostat

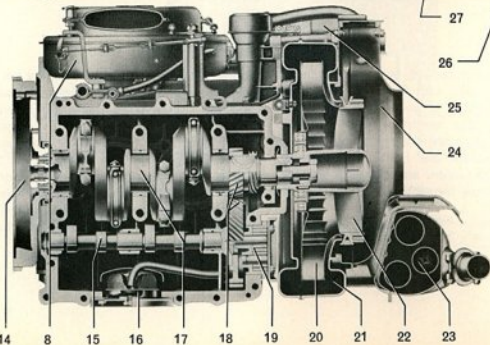

General Description

Engine

The engine, located in the rear of the car, is attached by four bolts to the recessed flange of the rubber mounted transmission case. The crankcase is made of a light alloy. Two pairs of cylinders are horizontally opposed. Each pair has a common cylinder head made of light alloy. The overhead valves are located in the cylinder heads and are operated by the camshaft via cam followers, push rods and rocker arms. The short crankshaft rests in four bearings and is induction hardened at its bearing surfaces. The camshaft is driven from it by means of helical gears. The connecting rods are provided with lead-bronze-bearings. The pistons are of light alloy with steel inserts.

Two down-draft carburetors with automatic chokes and accelerator pumps supply the fuel-air mixture.

The oil pump of the pressure lubrication system is driven by the camshaft. The oil is drawn from the crankcase via a strainer and forced via an oil cooler to the lubrication points. When the oil is thick, an oil pressure relief valve enables the oil to flow direct to the lubrication points by by-passing the oil cooler.

The engine is cooled by a fan mounted on the crankshaft. The fan sucks in air through an opening in the cooling air intake housing and forces it through the fins of the cylinders. The flow of cooling air is regulated by a thermostat and this ensures a constant operating temperature.

The engine is equipped with battery ignition. The spark advance is controlled automatically by a vacuum mechanism. The generator is driven by a V belt. The generator pulley can be adjusted to alter the V belt tension.

Chassis

The frame with its central tunnel is of pressed steel. It is forked at the front and supports the rubber mounted front axle. The engine-transmission unit is rubber mounted at three locations in a special sub-frame. The sub-frame with the engine and transmission unit is also rubber mounted at five locations to frame and body. A further rubber mounting supports the engine at the rear on the body. The following parts pass through the center of the frame:

Gear shift rod and fuel line, and, in guide tubes, the cables for hand brake, clutch, accelerator pedal and fresh air heating.

The front axle beam is of pressed steel and is provided with bearing tubes for the four torsion arms. The front wheels are individually suspended by two adjustable crossed torsion bars in the lower axle tube. A torsion bar extending between the two upper torsion arms serves as a stabilizer.

The roller type steering gear acts on the front wheels via divided tie rods. A steering damper ensures steering steadiness.

The rear axle is of the swinging half axle design. The rear wheels are independently sprung and have adjustable torsion bars.

Double-acting hydraulic shock absorbers in front and rear prevent excessive rebound.

Transmission and Rear Axle

Power from the engine is transmitted to the gears via a dry single-plate clutch. The transmission case houses the transmission with four forward speeds, one reverse, and the differential.

All the forward gears are synchronized. The gears are helically cut to provide silent operation.

The drive pinion and the ring gear are cut spirally. The two swinging rear axle shafts are pivoted in the differential.

Brakes

The hydraulic foot brake on the front wheels is provided with two brake cylinders per wheel and at the rear with one brake cylinder per wheel. The hand brake operates on the rear wheels via cables.

Body

The two-door body is made of pressed steel and electrically welded. It is bolted to the frame. Both door windows can be lowered. Hinged quarter windows and vent wings in the doors ensure draft-free ventilation. Both front seats can easily be adjusted while driving. The luggage compartments are situated under the front and rear hoods and behind the emergency seat. The front luggage compartment lock is cable-operated and the rear compartment is opened by means of a button above the licence plate. The fuel tank and spare wheel are located in the front luggage compartment. The engine compartment is accessible through the rear luggage compartment.

Heating System

The fresh air drawn in by the fan is heated in heat exchangers. It is emitted through three defroster vents on the windshield, two controllable outlets each in front foot well and under emergency seat and a defroster vent at the rear window. The heating is regulated by two levers situated beside the driver's seat on the frame tunnel.

Fresh Air Ventilation

The fresh air ventilation is regulated by means of two levers on the instrument panel. The air is drawn in through two openings in front of the windshield and enters through two vents on the windshield.

- 1 - Transmission shift lever
- 2 - Bonded rubber mounting
- 3 - Gearshift housing
- 4 - 4th gear train
- 5 - Gear carrier
- 6 - Oil drain plugs
- 7 - 3rd gear train
- 8 - 2nd gear train
- 9 - Main drive shaft, front
- 10 - 1st gear train
- 11 - Drive pinion
- 12 - Reverse gear
- 13 - Differential pinion
- 14 - Differential side gear
- 15 - Clutch release bearing
- 16 - Clutch operating shaft
- 17 - Main drive shaft, rear
- 18 - Reverse sliding gear
- 19 - Reserve shaft
- 20 - Oil filler plug
- 21 - Reverse drive gear
- 22 - Ring gear
- 23 - Fulcrum plates
- 24 - Rear axle shaft
- 25 - Differential housing

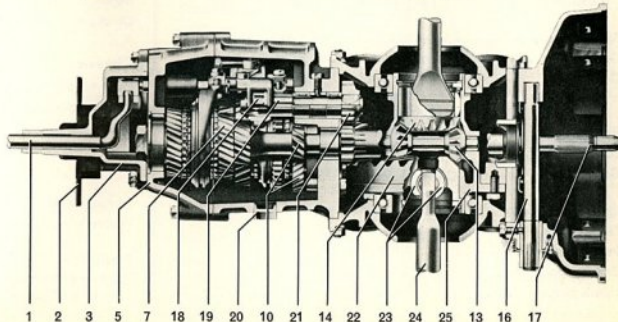
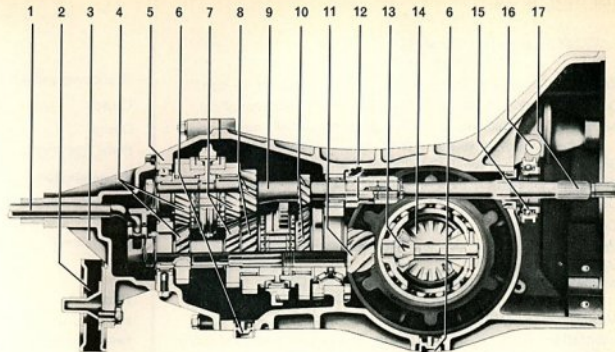

Technical Data

Engine

Design	4 cylinder, 4 stroke in rear of car
Arrangement of cylinders	Two pairs, horizontally opposed (flat four)
Bore	83 mm (3.27")
Stroke	69 mm (2.72")
Capacity	1493 c. c. (91.09 cu. ins.)
Compression ratio	8.5 : 1
Valves	Overhead
Valve clearance with engine cold	Intake 0.20 mm (.008") Exhaust 0.30 mm (.012")
Maximum output (SAE)	66 bhp. at 4800 rpm.
Lubrication	Force feed by gear pump. Oil cooler
Oil capacity	2.5 liters (5.3 U.S. pints; 4.4 Imp. pints)
Fuel delivery	Mechanical fuel pump
Carburetors	Two down-draft Solex 32 PDSIT
Cooling	Air cooling by fan mounted on crankshaft, controlled automatically by thermostat
Battery	6 Volt, 77 Amp.
Starting motor	6 Volt, 0.6 bhp.
Generator	6 Volt, 200 Watt at 2600 rpm., with regulator
Ignition distributor	Vacuum advance
Firing order	1 — 4 — 3 — 2
Initial spark advance	10° before TDC.
Breaker point gap	0.4 mm (.016")
Spark plugs	14 mm thread Bosch W 175 T 1

Beru 175/14

Champion L 85

or plugs with similar values from other manufacturers

Spark plug gap 0.7 mm (.028")

Clutch

Design Single plate, dry
Pedal free-play 10—20 mm (.4"—.8")

Transmission

4 forward speeds, 1 reverse

All forward gears synchronized and silent.

Gear ratios	First 3.80 : 1	Third 1.32 : 1
	Second 2.06 : 1	Fourth 0.89 : 1
		Reverse 3.88 : 1

Rear Axle

Power is transmitted through spiral drive pinion and ring gear, via two swinging half shafts to the rear wheels.

Ratio 4.125 : 1
Oil capacity of transmission 3.0 liters (6.3 U.S. pints; 5.3 Imp. pints)

Chassis

Front suspension 2 torsion bars, stabilizer
Rear suspension 2 torsion bars
Shock absorbers Double-acting telescopic shock absorbers at front and rear
Steering Roller type with divided tie rod, hydraulic steering damper
Turning circle Approximately 11.1 m (36 ft.)
Wheels Disc wheels with drop center rims
4½ J X 15
Tires 6.00 S — 15 L, tubeless
Inflation pressure
1 to 2 occupants Front 1.1 kg/cm² (16 psi.)
Rear 1.7 kg/cm² (24 psi.)

3 to 5 occupants	Front 1.2 kg./cm ² (17 psi.) Rear 1.8 kg./cm ² (26 psi.)
Wheelbase	2400 mm (94.5")
Track (Tread)	Front 1310 mm (51.6") Rear 1346 mm (53.0")
Toe-in (unladen)	4 to 6 mm (0.16"—0.24")
Camber (unladen)	1° 20' ± 10'
Foot brake	Hydraulic, acting on all wheels
Hand brake	Mechanical, acting on rear wheels

Dimensions and Weights

Length	4280 mm (168.5")
Width	1620 mm (63.8")
Height	1335 mm (52.6")
Ground clearance	138 mm (5.4")
Unladen weight (kerb weight)	910 kg (2006 lbs.)
Max. load	400 kg (882 lbs.)
Max. total weight	1310 kg (2888 lbs.)
Max. load on rear axle	790 kg (1741 lbs.)
Max. load on front axle	550 kg (1212 lbs.)

Fuel

Fuel consumption according to DIN 70 030 is approximately 8.0 liters premium fuel per 100 km i.e. 29 mpg. U.S., 35 mpg. Imp. (Measured consumption plus 10 % at half load and at a steady ¾ of top speed 109 kph/68 mph).

Fuel rating	Premium 95 octane (Res. F 1)
Oil consumption	0.5—1.0 liters per 1000 km 1.7—3.4 U.S. pints per 1000 miles 1.4—2.8 Imp. pints per 1000 miles

Refill Requirements

Fuel tank	40 liters (10.6 U.S. galls.; 8.8 Imp. galls.)
Engine	2.5 liters of engine oil (5.3 U.S. pints; 4.4 Imp. pints)

Rear axle and transmission . . .	2.5 liters of hypoid oil (5.3 U.S. pints; 4.4 Imp. pints)
Brakes	0.25 liters of brake fluid (0.53 U.S. pint; 0.44 Imp. pint)
Oil bath air cleaner	Approx. 0.38 liters of engine oil (.8 U.S. pints, .67 Imp. pints)
Container for windshield washer	Approximately 1 liter of water (1 quart) Air pressure: 2.5 kg./cm ² (36 psi.)

Performance

Maximum and cruising speed . .	145 kph (90 mph)
Climbing ability	First gear 45.5% Second gear 23.5% Third gear 14.0% Fourth gear 8.0%

Bulb Chart

V = Volt, W = Watt

Bulb for	Description according to German Standard DIN 72 601	Part Number
Headlights	A 6 V 45/40 W	N 17 705 1
Fog lamps	D 6 V 35 W	N 17 709 1
Parking lights and parking lamps	HL 6 V 4 W	N 17 717 1
Flashing indicator front and rear, stop light	R 6 V 18 W	N 17 731 1
Tail lights, licence plate light.	G 6 V 5 W	N 17 718 1
Warning lights for speedometer, clock and fuel gauge.	J 6 V 1.2 W	N 17 722 1
Interior and luggage compartment lights	K 6 V 10 W	N 17 723 1

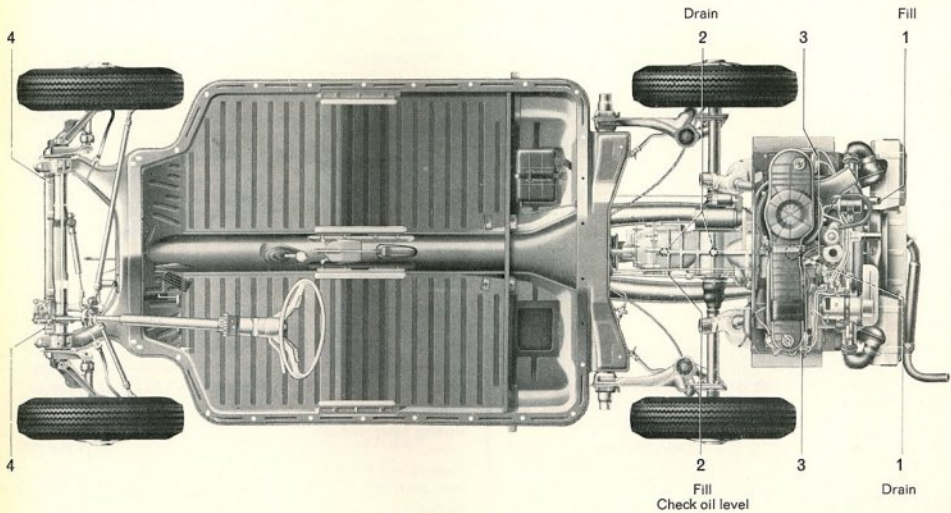

Lubrication Chart

500 km 300 miles	2,500 km 1,500 miles	5,000 km 3,000 miles	No.	Lubrication Points	Every
			1	Engine: Change oil, clean oil strainer	3 000 miles 5 000 km
			2	Transmission: Check oil level	
				Lubricate door and hood locks	
			3	Lubricate carburetor linkage	
			4	Lubricate front axle	6 000 miles 10 000 km
			2	Transmission: Change oil, clean magnetic oil drain plugs	30 000 miles 50 000 km

Lubricants

Lubricant	Lubrication Points	Specifications			
		Temperature °C °F		Viscosity Grade	
Engine oil (Branded HD oil for spark-ignition engines)	Engine Carburetor linkage Oil bath air cleaner	above	0	32	SAE 30
		below	0	32	SAE 10 W
		below	-25	-13	SAE 5 W
Hypoid oil	Transmission	SAE 90 all the year*			
Universal grease	Door and hood locks	cold-resistant water-repellent high pressure grease			
Lithium grease	Front axle Front wheel bearings Breaker arm fiber block in distributor	Multi-purpose grease			

* SAE 80 all the year in countries with arctic climates

Maintenance Chart

500 km 300 miles	5,000 km 3,000 miles	Operation	Every	500 km 300 miles	5,000 km 3,000 miles	Operation	Every
		Check for tightness: Nuts and bolts on chassis, body, engine, rear axle, front axle and steering				Check cooling air bellows	3000 miles 5000 km
		Check engine and rear axle for leaks				Check clutch pedal free-play	
		Check tire pressures and wheel mounting bolts for tightness				Check dust seals of ball joints and tie rod ends, security of tie rods and steering damper	
		Check V-belt	3000 miles 5000 km			Check axial play of upper torsion arms, camber and toe-in of front wheels	
		Check air cleaner, clean lower part if necessary				Check steering gear adjustment	
		Clean fuel pump filter				Check tires for wear and damage, check tire pressures	
		Check breaker points, lubricate distributor, check contact breaker gap and timing				Check brake system for damage and leaks, Check brake fluid level and hand and foot brake adjustment	
		Check valve clearance				Check thickness of brake linings	
		Check spark plugs and compression				Check battery, check electrical system and headlight adjustment	
		Check exhaust system for damage, Check rubber valve in crankcase ventilation system.				Road test: Check foot and hand brake operation, Check heating, idling adjustment and ventilation	
						Clean, grease and adjust front wheel bearings	30000 miles 50000 km

Tools and Accessories

- 1 Tool roll
- 1 Spare wheel, complete
- 1 Jack
- 1 Wheel cap removal tool
- 1 Combination pliers
- 1 Screwdriver with reversible blade for Phillips and slotted screws
- 1 Open end wrench 8 × 13 mm
- 1 Spark plug socket wrench with bar
- 1 Wrench for wheel mounting bolts with bar (the bar is also used to operate the jack)

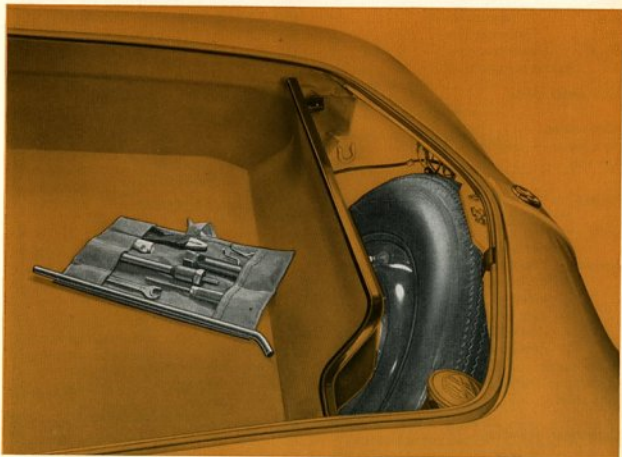

- Accelerator pedal 5
 - accelerating 20
- Accessories 61
- Air cleaner — cleaning 35
- Ash tray 12
- Battery — maintenance 46
 - care in winter 23
- Body — airing 28
 - description 54
- Brakes — adjusting 44/45
 - application 21
 - bleeding 45
 - care in winter 23
 - checking 15/44
 - description 54
- Brake pedal 5
- Breaking-in (running-in) 19
- Bulb chart 57
- Carburetor adjusting 41
 - type 56
- Camber 57
 - setting 43
- Care of the car 26
- Chassis — care in winter 23
 - description 53
 - lubrication 32
 - number 4
- Chromium-plated parts — care 28
- Cigarette lighter 12
- Climbing ability 57
- Clock 12
- Clutch — design 56
 - pedal 5
 - pedal free-play 42/56
- Cold weather hints 22
- Compression 39
 - ratio of engine 56
- Contact breaker points — setting 37
 - cleaning 36
- Controls and instruments 5
- Cooling of engine 53
- Description — general 53
- Dimensions — overall 57
- Dimming — headlights 9
- Dipstick 16
- Doors 6
 - care of weather strips 28
 - adjusting 51
 - inside handle 6
 - lubrication points 33
 - locks frozen 23
- Driving down-hill 19
- Economy 20
- Engine — compartment 14
 - description 53
 - design 56
 - lubrication (oil change) 56
 - number 4
 - oil change in winter 23
- Engine — oil change and refill requirements 29
 - oil strainer 29
 - speed 57
 - sectional view 52
 - technical data 56
 - type of oil 30
- Firing order 56
- Flashing indicator bulb — replacement 49
- Flashing indicator switch 10
- Fog lamps 9
 - adjusting 47
 - replacing bulb 48
- Foot brake — adjusting 44
 - bleeding 45
 - description 54
- Fresh air ventilation — operation 11
 - description 54
- Front axle — description 53
 - lubrication 32
 - technical data 43/56
- Front seats — adjustment 7
- Front wheel bearings — adjusting 42
 - lubrication 42
- Fuel consumption 57
- Fuel delivery 56
- Fuel filter-cleaning 36
- Fuel tank — capacity 15/57
 - reserve 15
- Fuse box 51
- Fuses — replacing 51
- Gear lever 5
- Gear shifting 19
 - on gradients 20
- Generator 56
- Ground clearance 57
- Hand brake — adjusting 45
 - description 54

Headlights	9	Paintwork — preservation	26	Tail light — replacing bulb	49
— aiming	47	— polishing	27	Technical data	56
— changing bulb	48	Parking your car	21	Tires — inflation pressure	16/56
— flasher	10	Parking lamps	10	— maintenance	24
Heating — description	54	— bulb replacement	48	— M + S tires	23
— operation	22	Parking lights	9	— size	56
Horn lever	5	Practical driving	18	— wear	24
Identification plate	4	Ratios — rear axle	56	Toe-in	57
Idling — checking and adjusting	41	— transmission	56	— adjusting	43
Ignition — setting	36	Rear axle — description	54	Tools and accessories	61
— distributor	56	— technical data	56	Torsion arms — checking play	43
— firing order	56	— transmission of power	56	Towing	21
— lubrication of distributor	37	Rear view mirror	8	Track (tread)	57
Instrument light	9	Reserve gear	18	Transmission — description	54/56
Interior light	10	Safety belts	14	— oil change	
Jack — application	24/25	Seat adjustment	7	and capacity	31
Keys	6	Sectional view with explanations	60	— sectional view	55
Leatherette — care of	28	Shifting gears	19	— oil change in winter	23
License plate light — replacing bulb	49	Shock absorbers — design	53	Turning circle	56
Lighting	9	Snow chains	23	Type of fuel	15
Lubricants	59	Spare wheel	24	Upholstery — care of cloth	28
Lubricant — additives	31	Spark plugs — checking and cleaning	39	Valves — adjusting	40
Lubrication service	29	— gap	23/39	— arrangement	56
Lubrication chart	59	— removal	39	— clearance	40/56
Luggage compartments	13	Speedometer	5	V-belt — checking and adjusting	34
Maintenance service	34	Speed ranges	19	Vent wing	5
Maintenance chart	60	Spots — removal	28	Warning lights	18
Maximum output	56	Starting	17	Washing your car	26
Maximum speed	57	Starting motor	56	Weights	57
Oil consumption	57	Steering ignition lock	17	Wheel base	57
Oil level — engine	16	Steering — adjusting	43	Wheels — balancing	24
— dipstick	16	— type	56	— changing	24
— specifications	30	Stop light — bulb replacement	49	— rim size	56
— steering gear	32	— checking	16	Windows — cleaning	28
— transmission	31	Sun visors	8	Window regulator handle	5
Operating instructions	6	Suspension — front	53	Window weather strips — care	28
		— rear	53	Windshield wiper switch	8
				Windshield washer	8

© 1964 Volkswagenwerk Aktiengesellschaft
All rights reserved.

May not be reproduced or translated in
whole or in part without the written consent
of Volkswagenwerk AG.

Specifications subject to alteration
without notice.

158.851.20 · Printed in Germany · 8.64

Druck: Albert Limbach, Braunschweig



