

# *VW 1500*

Instruction Manual





# VW 1500

## Instruction Manual

August 1965

V O L K S W A G E N W E R K A G · W O L F S B U R G



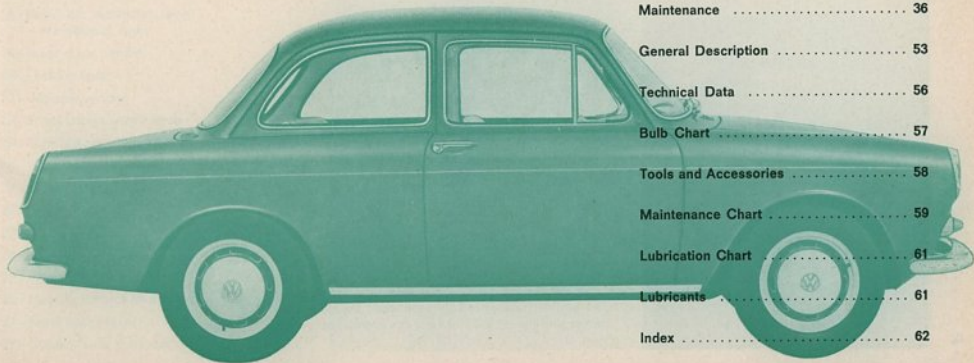

Identification Plate, Chassis and Engine Number . . . . .	4
Controls and Instruments . . . . .	5
Operating Instructions . . . . .	6
Practical Driving . . . . .	20
Cold Weather Hints . . . . .	24
Care of the Tires . . . . .	26
Care of the Car . . . . .	28
Lubrication . . . . .	31
Maintenance . . . . .	36
General Description . . . . .	53
Technical Data . . . . .	56
Bulb Chart . . . . .	57
Tools and Accessories . . . . .	58
Maintenance Chart . . . . .	59
Lubrication Chart . . . . .	61
Lubricants . . . . .	61
Index . . . . .	62



#### **The service booklet**

There is a pocket for the service booklet in the sun visor on the driver's side. Please ensure that the booklet is always in the pocket. The mileage visible at the ends of the coupons will remind you when the next lubrication and maintenance service is due.



In the vehicle documents you will find the model designation and the chassis and engine numbers. The police or Traffic Department attach much importance to these details.

**The identification plate** is found under the front hood beside the hood lock.



**The chassis number** is found on the frame tunnel under the rear seat.



**The engine number** is found between the oil cooler and the carburetor near the crankcase joint.

- 1 - Vent wing handle
- 2 - Switch for windshield wipers and washer
- 3 - Switch for lighting and instrument panel lighting
- 4 - Warning light – Green – Parking lights
- 5 - Warning light – Green – Turn indicators
- 6 - Warning light – Blue – Headlight high beam
- 7 - Warning light – Red – Generator
- 8 - Warning light – Green – Oil pressure
- 9 - Fuel gauge
- 10 - Speedometer
- 11 - Ash tray
- 12 - Fresh air ventilation lever – Windshield, left
- 13 - Fresh air ventilation – Foot level
- 14 - Fresh air ventilation lever – Windshield, right
- 15 - Inner door handle
- 16 - Locking lever
- 17 - Window winder
- 18 - Front hood control knob
- 19 - Turn indicator lever with dimmer switch
- 20 - Horn ring
- 21 - Steering ignition lock
- 22 - Clutch pedal
- 23 - Brake pedal
- 24 - Accelerator pedal
- 25 - Gear lever
- 26 - Heating control lever
- 27 - Hand brake lever
- 28 - Control lever for heating in rear foot well

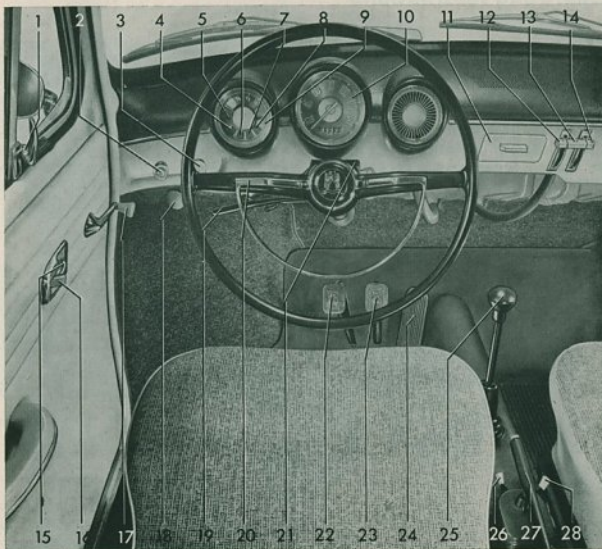



## Operating Instructions

**Before driving off** acquaint yourself with your new car. You have been given a separate key for the door lock and the steering ignition lock. You should take note of the key numbers so that you can get a replacement if you should lose a key.

**The doors** are opened with the press button under the door handle. To enter a locked vehicle, unlock the door on the driver's side by turning the key one quarter of a turn in the lock. The door on the passengers side unlocks automatically when opened from inside.

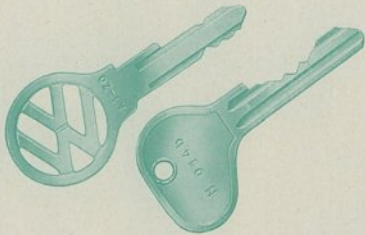

Naturally both doors can also be locked from outside. It is, however, more convenient to press in the lever above the inner handle when getting out and then depress the knob under the outside handle as you close the door. If the door closes unintentionally after the inner lever has been depressed it will not lock and thus the danger of getting locked out is reduced to a minimum.







**The front seats.** The seats can be adjusted individually whilst driving, by merely pulling up the lever under each seat.

The rake of the front seat backs can be adjusted to eight different positions by turning a knob.

To remove the front seats, a leaf spring on the inner runner must be pressed down. This spring prevents the seat from sliding out forwards unintentionally.



**The rear view mirrors** are adjustable and should be set to give clear vision to the rear at all times without having to alter ones position.

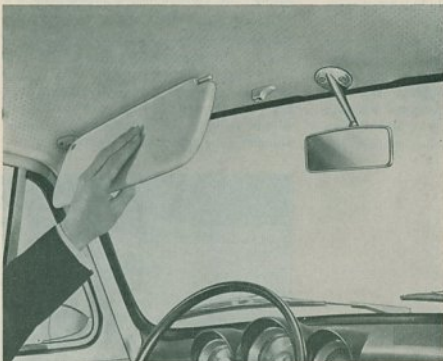

**The sun visor** can be swivelled towards the door window to give protection against the sun from the side.

The **windshield wipers** are switched on with the left push-pull switch on the instrument panel. When switched off, the wipers return to the park position automatically.

The **windshield washer** is operated with the knob in the center of the windshield wiper switch. The washer is worked by compressed air so that by just holding the knob down you can spray water on to the windshield until the field of vision is quite clear.

Do not forget to check the windshield washer container from time to time. It is located under the front hood in front of the spare wheel and holds about 1 quart of water. As the air pressure in the container escapes when the cap is removed, it is advisable to refill the container at a filling station. The

container can be filled until it overflows. The pipe in the container neck ensures that there is always sufficient air to operate the washer.

The correct air pressure is 2.5 kg./cm<sup>2</sup>. (36 psi.). The addition of 25% pure spirit to the water in winter will protect it from freezing down to a temperature of approximately -12 °C (10 °F). An odourless anti-freeze solution can be used instead of methylated spirits. The correct mixing proportions are given by the manufacturers.

The wiper blades should be removed occasionally and thoroughly cleaned with a hard brush and methylated spirits or a strong detergent solution. Particularly during long dry periods they tend to become clogged with tar splashes, oil and insects. The blades should be replaced once a year.

The **lights** are switched on with the right-hand push-pull switch on the instrument panel. When the parking lights are switched on - first stop - a green warning lamp in the fuel gauge lights up. To switch on the headlights, pull the switch out to the second stop. The dimmer switch is installed in the flashing indicator switch on the steering-column tube.

The **instrument panel lighting** can be regulated by turning the light switch and can be switched off by turning the switch to the left.

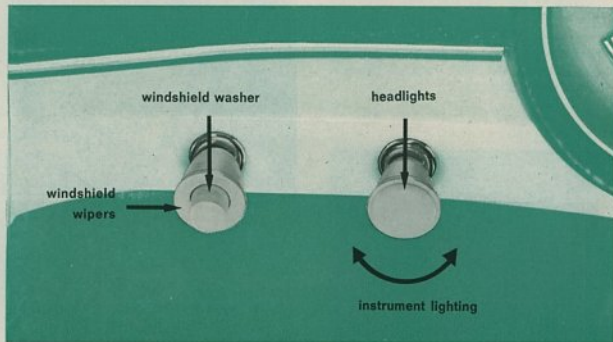

**The interior light** is situated above the left door. The switch is operated by pushing in the light by hand as follows:

Light in central position

Interior light comes on when a door is opened

Light pressed in on right

Interior light switched on, with doors closed

Light pressed in on left

Interior light switched off, with doors open

**Turn indicator lever.** You can operate the flashing indicator lever with your fingers without taking your hands off the steering wheel.

Lever upwards – right indicator

Lever downwards – left indicator

Two warning lights in the fuel gauge flash whilst the indicators are in operation. The indicators are self-cancelling.

The button in the indicator lever serves as dimmer switch. A blue high beam warning light is situated in the fuel gauge.

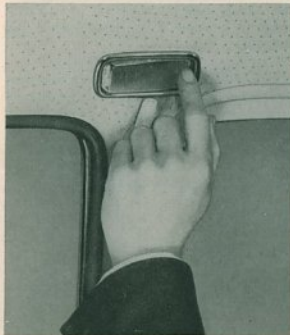

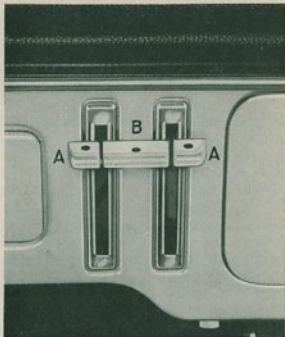

The fresh air ventilation can be regulated by the three levers on the instrument panel. The two outer levers - A - operate the ventilation for each side of the car individually through two vents on the lower edge of the windshield. The center lever - B - regulates the ventilation at foot level. The amount of fresh air entering will increase the further the levers are pushed down. When all three levers are in the upper position, the air inlets are closed.

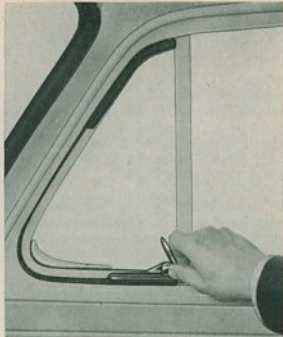

The warm and fresh air must be cleared to ensure correct vehicle ventilation. Even in cool weather a vent wing should be slightly opened. The windows will then remain clear.



The sliding roof is operated by a crank which is situated in a recess beside the sun visor.

After pulling down the handle, the roof can be opened or closed as required. It will remain fixed in any position.

To close, the sliding roof is cranked fully forward to the stop. Now turn the handle back a little and fold it into the recess.

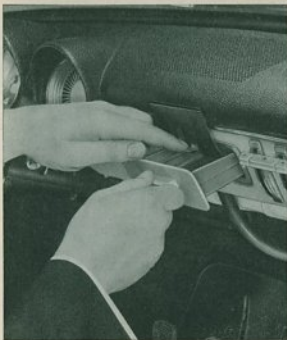

The ash tray in the instrument panel can be removed by depressing the spring.

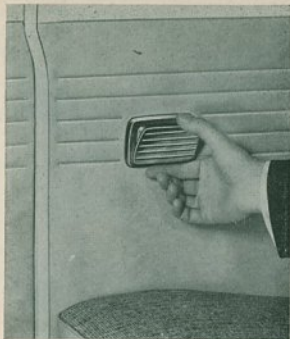

The rear ash tray must be pressed down slightly to remove it. After cleaning, it must be pressed back into the housing evenly at top and bottom.





The luggage compartments are theft-proof when the car is locked. The knob for the front hood is situated under the instrument panel on the left. The hood is released when the knob is pulled and is opened by pressing up the catch beside the lock.

When closing the hood, always ensure that the catch engages properly. Never attempt to close the hood by pressing it at the side, always exert the pressure near the lock.



The rear hood is opened by pulling the lever in the left-hand lock pillar.



The **engine compartment** is accessible from the rear luggage compartment. Release the buttons and roll back the lining. Turn the handles on the engine compartment lid to the left, raise the lid and secure it by pressing it against the spring on the upper edge of the luggage compartment or take it out.

Turn the handles to the right to lock the engine compartment lid and secure them by pressing them down fully.

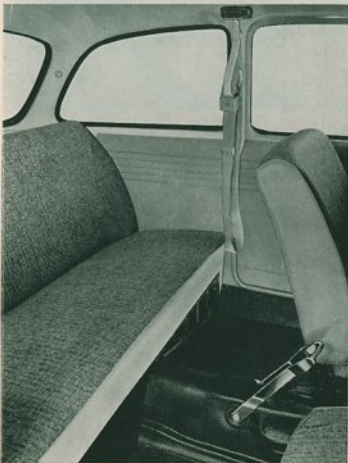

#### **Safety belts**

can be obtained from every VW Dealer. The belts for the driver and front passenger are attached to the lock pillar and the frame tunnel. You will find the mountings for the rear seat passenger belts to the left and right of the rear seat back rest and under the back rest above the frame tunnel.



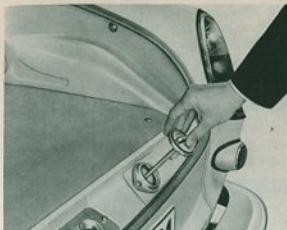

The oil level should only be checked when the engine is not running. It should always be between the two marks on the dipstick and must never fall below the lower mark. Wipe the dipstick with a clean rag before checking the oil level.

If possible always use the same branded HD oil (for Service MS).

**Tires.** Correct tire pressures are essential for ensuring the excellent road-holding properties of your car. It is not too much to be expected for you to check the tire pressure occasionally.

When the car is fully loaded the tires pressures should be 1.2 kg/cm<sup>2</sup> (17 psi.) at the front and 1.8 kg/cm<sup>2</sup> (26 psi.) at the rear. Otherwise 1.1 kg/cm<sup>2</sup> (16 psi.) pressure at the front and 1.7 kg/cm<sup>2</sup> (24 psi.) at the rear is sufficient.

Variant – 375 kg (826 lbs.) –:

with half payload

front 1.2 kg/cm<sup>2</sup> (17 psi.)

rear 1.8 kg/cm<sup>2</sup> (26 psi.)

with full payload

front 1.2 kg/cm<sup>2</sup> (17 psi.)

rear 2.6 kg/cm<sup>2</sup> (37 psi.)

Variant – 465 kg (1025 lbs.) –:

with half payload

front 1.2 kg/cm<sup>2</sup> (17 psi.)

rear 1.8 kg/cm<sup>2</sup> (26 psi.)

with full payload

front 1.2 kg/cm<sup>2</sup> (17 psi.)

rear 3.0 kg/cm<sup>2</sup> (43 psi.)



For long, high speed motorway trips, the tire pressures should be increased by 0.2 kg/cm<sup>2</sup> (3 psi.) at front and rear.



### **Variant**

Apart from the front luggage compartment there is also a large load compartment which is accessible through the rear door.

**The rear door** is opened by the knob under the licence plate. Lift the door by the recess under the knob. It is held in the fully open position by spring tension.

When closing it you merely have to slam it gently until it engages in the lock. It is locked by the same key which you use for the door.



**The loading surface** can be increased by more than half its size by tipping the rear seat forward. To do this, raise the seat cushion and tip the backrest forward with the handle.

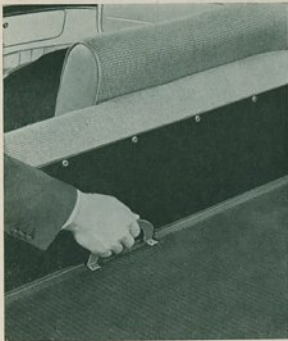

When the seat has been tipped forward, the seat cushion and backrest are held by two retaining pins. In the normal position a retaining device automatically prevents the backrest from tilting forward.

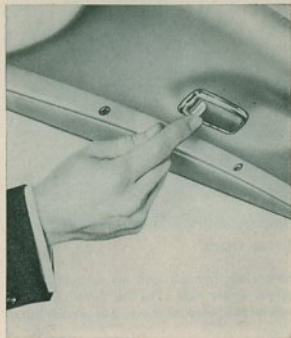

**The load compartment lighting.** An additional interior light for the load compartment is situated on the roof member above the rear door.

## Starting the engine

The ignition and starter are switched on, one after the other, by means of the steering ignition lock. As starter operation stresses the battery heavily, other big current users, such as the headlights, windshield wiper and radio, should not be switched on when starting. Make sure, also, that the gear shift lever is in neutral.

When switching on the ignition, turn the key half a turn from the "Halt" position or a quarter of a turn from the "Garage" position to the right. The red generator warning light and the green oil pressure warning light in the fuel gauge will come on. Operate the starting motor immediately by turning the key further to the right.

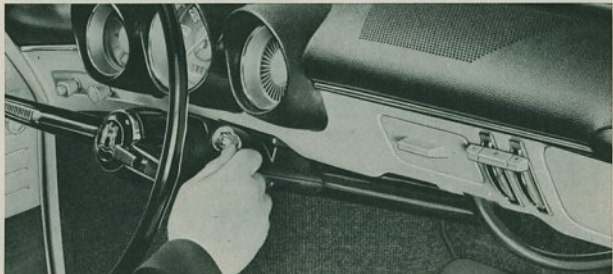

**At temperatures above freezing point** or when the engine is still warm, depress the accelerator pedal slowly while operating the starter. Only when the engine does not start straight away and when the engine is very warm must the accelerator be fully depressed and held in this position.

**At temperatures below freezing point** and when the engine is cold, depress the accelerator pedal fully and then release it before switching on the ignition. This enables the automatic choke to close the choke valve. As the engine and transmission oil tends to become thick when cold, you should also declutch when starting so that the starter motor only has to turn the engine.

As soon as the engine starts, release the ignition key so that the starter is switched off. You can move off at once. The automatic choke regulates the mixture and idling speed to suit the operating temperature. Do not race the engine when it is still cold.

### Please check

the brakes, lighting, and the amount of fuel before every trip. The oil level and tire pressures should be checked at regular intervals.

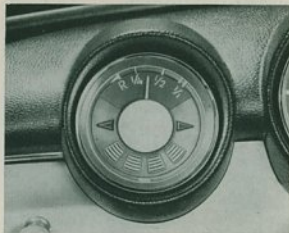

The fuel tank capacity of 40 liters (10.6 US gall.; 8.8 Imp. gall.) is sufficient for 450 km (280 miles). When the ignition is switched on the fuel gauge in the instrument panel will show you how much fuel you actually have. When the needle registers "R" (reserve) it is time to fill up at the next opportunity. The remaining 5 liters (1.3 US gall.; 1.1 Imp. gall.) in the tank will last for about 55 km (34 miles).

The choice of fuels is left to you. The VW engine is so designed that it will run satisfactorily on all normal reputable fuels which fulfil the octane requirements of the engine (90 O. N.). If regular fuels with adequate anti-knock properties are not available, premium fuels should be used or mixed with the regular fuel. All good brands, including premium and regular mixtures, are distinguished by their consistent composition and freedom from harmful ingredients. The fuel tank filler is under the front hood which is opened by the knob under the instrument panel.

The brakes must be checked before starting out on a trip as the safety of your car depends mainly on them. When the car is in motion, depress the brake pedal a few times to make sure that the brakes are working efficiently.

The stop and turn indicator lights are an essential part of the lighting system. The ignition has to be switched on if you wish to check them.

If a turn indicator bulb is defective the other indicator bulb and the warning lights in the fuel gauge will flash considerably quicker.

The stop lights only operate when the foot brake is applied.



If the engine does not start within the first 10 seconds, pause for about the same length of time to rest the battery before repeating the starter operation. The ignition will have to be switched off first and then on again as a non-repeat lock in the switch prevents the starter from being operated repeatedly when the ignition is on and thus being damaged by the engine when it is running. The starting procedure should not be interrupted if the engine is heard to fire a few times.

The **generator warning light** goes out when the speed is increased. If it comes on while you are driving, the generator is no longer charging. In this case you can proceed but, if possible, only as far as the next workshop as otherwise the battery will soon run down.

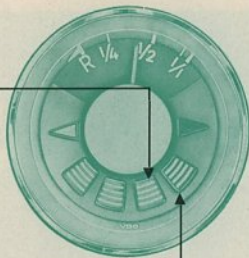

The **warning light for the oil pressure** goes out when the engine is started. If this warning light comes on whilst driving you must stop at once as the chances are that the oil circulation has been interrupted. Check the oil level at once. If the oil level is correct, get in contact with the nearest VW workshop.

#### Caution

Be careful when starting the engine in the garage. Provide ample ventilation so that the exhaust fumes, which contain carbonmonoxide gas, can escape.

## Practical Driving

**Breaking-in instructions** are not necessary. The most modern production and inspection methods have made it possible to dispense with the initial speed restrictions which are normally required. You can drive the vehicle at full speed from the first day.

It is advisable, however, to observe certain general driving rules.

### Gear shifting

Glance occasionally at the speedometer especially during the initial period.

Shift the gears within the permissible speed ranges only:

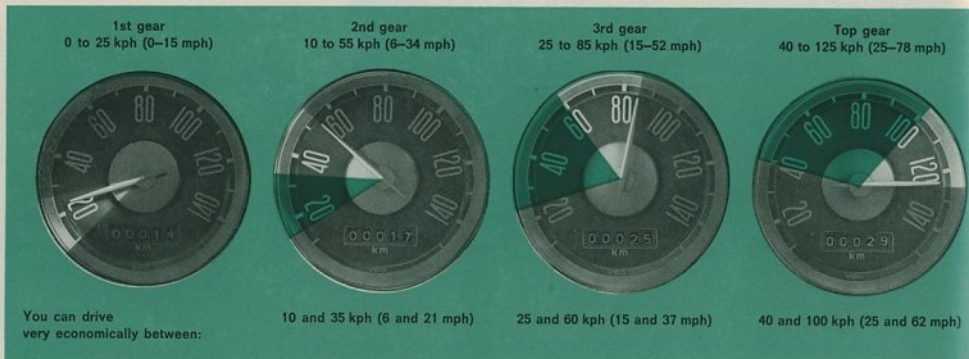

Do not race or labor the engine in the individual gears. This practice can have a decisive effect on the life of the engine.

Engage the reserve gear only when the car is stationary. A locking device prevents unintentional shifting. Depress the gear lever slightly and then move it to the left and to the rear to engage reverse.



### Shifting to a lower gear

Shift down to a lower gear in good time when on inclines and also when accelerating from low speeds. The transmission of your car is fully synchronized so please do not hesitate to shift the gears.

Certain speed ranges have to be adhered to when shifting to a lower gear. Shifting down to a lower gear at excessive speeds puts an unnecessary strain on the transmission. On the other hand very low speeds in the individual gears are harmful to the engine. Shift down from 4th to 3rd gear approximately between 85 and 40 kph (52 and 25 mph) and from 3rd to 2nd gear between 55 and 25 kph (34 and 15 mph). The 1st gear is only used for moving off, driving at walking pace or on very steep inclines.

When shifting gears, it is absolutely essential to depress the clutch pedal fully. Incomplete declutching makes gear shifting difficult and leads to rapid wear of the synchronizer stop rings.

### Brakes

The brake responds to even the slightest foot pressure. Apply the brakes carefully and avoid locking the wheels. Locked wheels will not shorten the braking distance but may cause you to lose control over the vehicle and will affect the tires.

When driving downhill, make use of the braking effect of the engine and shift to that gear which you would use in driving uphill. The ignition must never be switched off when going downhill.

Violent braking can only be justified in an emergency. Nevertheless, it is advisable to check the full braking effect at certain intervals so that you will be familiar with the behaviour of the car and the actual braking distance.

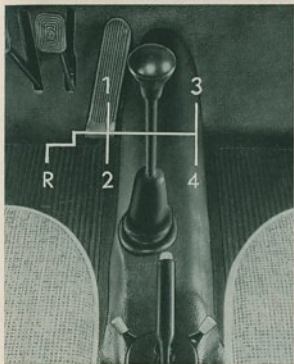

**Economical operation** is one of the outstanding features of your car. However, getting a few extra miles from each gallon depends on your driving habits:

Make use of the lower speed ranges of the individual gears. For instance on level roads at a speed of between 40 and 60 kph (25 and 37 mph) use the 4th gear in preference to the 3rd gear.

Accelerate gradually. Under normal driving conditions shift to 2nd gear at 10 kph (6 mph), to 3rd gear between 25 and 35 kph (15 and 21 mph) and to 4th gear between 40 and 60 kph (25 and 37 mph).

Only use the full acceleration and excellent braking effect of your car when it is absolutely necessary.

Do not pump the accelerator pedal unnecessarily. Even the small quantity of fuel additionally discharged each time the accelerator pedal is depressed results in a marked increase in the overall fuel consumption.

Do not continue to accelerate on inclines when your speed drops, shift in good time to a lower gear. There are, however, no hard and fast rules for this: If, for instance, the speed drops on an incline in 4th gear from 110 kph (68 mph) to 90 kph (55 mph) and lower, it is best to shift to the 3rd gear between 80 and 70 kph (50 and 43 mph). If you are driving at a speed of between 40 and 60 kph (25 and 37 mph) in 4th gear on a level road shift to 3rd gear right at the beginning of the incline.

Reduce your speed in good time before corners and when stopping. Do not coast downhill.

High speeds always result in increased fuel consumption. However, you can drive quickly and economically if you accelerate to the desired speed and then ease the pedal back slowly to the point where the vehicle just remains at this speed. This method can prove very economical, particularly on long motorway trips.

The most advantageous engine operating conditions result from brisk driving and correct gear shifting.

## Parking

Parking in limited spaces can be made quite simple:

Stop your car level with the car in front of the space. Turn the steering wheel sharp to the right and reverse slowly into the gap:



When the front bumper of your car is level with the rear bumper of the car ahead of you, turn the steering wheel fully to the left and back up further towards the curb:



Now turn the steering wheel to the right again and pull up a little bit, until both ends of the car are as close to the curb as possible:



When parking on a steep slope, set the handbrake and also engage first or reverse gear. **Remove the key at the "Halt" position only when the vehicle is stationary.** This locks the steering and protects the vehicle against theft.

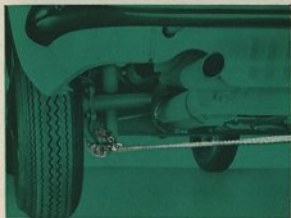

## Towing

Just in case you wish to attach a towrope to your vehicle one day, please note that the bumpers are not suitable for this purpose. At the rear we recommend that the rope is attached to a lower shock absorber bracket. This point is not very easy to reach but it will at least ensure that your desire to help does not result in damage to your vehicle.

At the front, the rope should be attached to the lower axle tube.

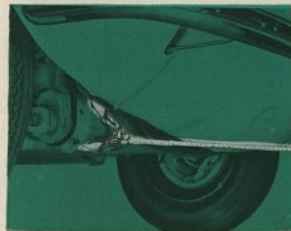

## Cold Weather Hints

Your car has two features which you will appreciate in the winter: Air cooling and heating. You can leave your car out in bitter without fear. Its air-cooled engine will always be ready to start and supply warm air for the interior of the car.

**The warm air heating** can be fully regulated. The distribution of the warm air can be varied to suit the wishes of the occupants by means of controllable outlets at foot level.

The left-hand lever between the two front seats controls all the heating. The right-hand lever controls the heating in the rear foot well. The outlets in the front foot well can be closed with slides on the Sedan and with a knob under the instrument panel on each side on the Variant.

At very low temperatures, it is advisable to always close the rear outlets when first moving off. This increases the flow of air to the windshield and also helps to prevent steaming up when air humidity is high. As soon as the windshield is clear, the rear foot level outlets should be opened so that the interior of the body heats up as quickly and uniformly as possible.

If you open a vent wing slightly when the heating is on, the heat output will increase noticeably because the fan can then force the warm air into the body more easily.

Never attempt to influence the cooling and heating of your car in winter by covering the air intake slots below the rear window. These slots must always remain open to ensure the flow of fresh air to the carburetor and fan.

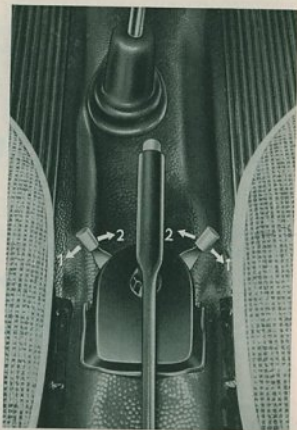



The **SAE 30 engine oil** will thicken at temperatures below freezing point and result in difficult starting. Change over to the thinner **SAE 10 W engine oil** at oil changes when temperatures under freezing point are expected.

If you drive mainly short distances and in city traffic in the winter we recommend that you have the oil changed every 2,500 km (1,500 miles). If you only cover a few hundred miles a month under these conditions it is advisable to have the oil changed every 6 to 8 weeks. In the warmer seasons, additional oil changes are unnecessary and uneconomical.

In territories where exceptionally low temperatures prevail (below  $-25^{\circ}\text{C}$  /  $-13^{\circ}\text{F}$ ), **SAE 5 W** oil should be used instead of **SAE 10 W**. The oil should be changed every 1250 km (750 miles).

The **SAE 90 transmission oil** can generally be used all the year round. Only in countries with arctic climates is it necessary to replace it with the thinner **SAE 80**.

The **chassis** is naturally exposed to very severe conditions in the winter. The steadily increasing use of chemicals to de-ice the roads produces solutions which attack even the most durable paintwork after a time. The underside of your Volkswagen is sprayed with a wax-based compound to protect it from these influences. It is advisable to examine the protective film at the beginning of the winter and have it repaired by respraying so that the full protective effect is retained. Oil-based anti-corrosion compounds should not be applied to the wax-coated underside of the vehicle.

The **battery** requires special care in winter because of the increased consumption of current when starting the engine and using the lights at night. Furthermore, its efficiency decreases at lower temperatures. If the car is mostly used over short distances or in city traffic, it is advisable to have the battery recharged occasionally. The connections between battery and starting motor must be kept perfectly clean.

The **spark plugs** should not have an excessively large gap especially in winter. The normal spark plug gap is 0.7 mm (.028"). In extremely cold weather the gap can be reduced to between 0.4 and 0.5 mm (.016" and .020") to facilitate starting.

The **brakes** are exposed to splash water and condensation which in winter is apt to freeze in the brake drums. Therefore, when parking your car, do not set the handbrake, but shift to first or to reverse gear.

The **door lock** can freeze up in winter, especially if water gets into the lock cylinder when washing the car. Do not aim the water jet directly at the lock, but instead, cover up the key hole when washing. A frozen lock can be opened by warming the key before insertion and then squirting anti-freeze into the lock cylinder straight away.

**Tires** with badly worn treads are very dangerous particularly in the winter so ensure that they are replaced in good time.

M+S tires with special heavy treads give good road holding in snow and slush. They can be fitted to all four wheels. M+S tires should however, never be fitted to the front wheels only. Better still are M+S ice tires (spiked) which increase the safety margin even on hard snow and ice. Even with these tires, which should always be fitted to all four wheels, you should not allow yourself to be misled into driving faster than you would under the same conditions with normal M+S tires.

In general, special winter tires only have real advantages when conditions on the roads are really wintry. For safety reasons, it is not advisable to drive a vehicle fitted with any type of winter tire at top speed. You cannot expect a winter tire to have the same degree of adhesion on dry snow free roads as a normal tire. Furthermore, under these conditions M+S tires wear rapidly, particularly at high speeds.

Clips must be fitted to the lower torsion arms when M+S or spiked tires are used in order to prevent the tires from rubbing on the wheel housing on full lock.

**Snow chains**, in conjunction with normal winter tires, can only be used on the rear wheels. Only thin chains which do not stand clear of the tire tread and walls more than 15 mm, including tensioner, are suitable. When driving over long stretches of road which are free of snow the chains should be removed. They serve no useful purpose here and merely damage the tires and wear out quickly.

## Care of the Tires

Apart from the tire pressures, your driving habits also affect the tire wear considerably. Rapid acceleration, violent braking and cornering result in more excessive tire wear as compared to careful driving.

Avoid overloading the car and protect the tires from intense sunlight, fuel or oil.

The tires should be checked occasionally for foreign matter and damage. The tire tread should never be allowed to wear down to a thickness of less than 1 mm (.04") which is the absolute minimum required for safe usage. If the tires show signs of uneven wear after a considerable mileage consult your local VW dealer.

For smooth running at high speeds and long tire life, it is important to have the wheels balanced statically and dynamically. The wheels of your car are balanced. As the wheels can get out of balance owing to natural tire wear, they should be balanced every 10,000 km (6,000 miles).

When mounting the tires, the red mark should be positioned at the valve.

### Changing Wheels

The spare wheel, jack and tools are found under the front hood which is opened by means of the knob under the instrument panel. The jack is secured by a clip near the spare wheel.

Set the hand brake.

Take off the wheel cap with the removal tool and loosen all four wheel bolts about one turn with the wrench and operating bar.

Insert the jack in the square tube on the frame.

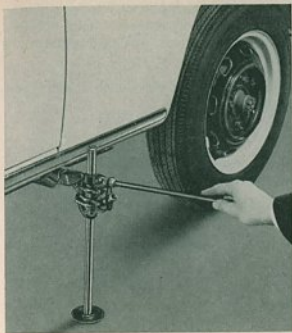

Push down the jack base plate until it makes contact with the ground. Place bar in upper link on jack and raise vehicle until wheel is clear of ground.

Remove wheel bolts and take off the wheel.

Raise the car until the four holes in the wheel are roughly lined up with the threaded holes for the wheel bolts.

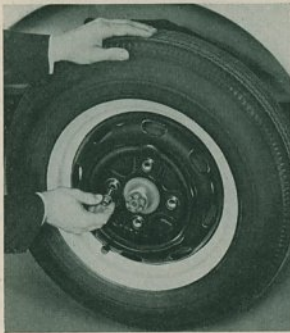

Insert one wheel bolt and tighten it so far that the wheel can be swung round this point by hand until the remaining holes are in line with the threaded holes.

Insert the other wheel bolts.

Tighten the bolts until the wheel, centered by the spherical shape of the bolt heads, contacts the wheel hub all round.

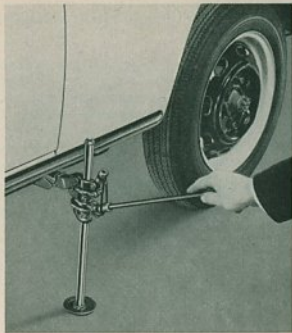

Place bar in lower link on jack and lower the vehicle.

Tighten the bolts evenly.

Install the wheel cap with a sharp blow with the hand.



## Care of the Car

**Clean and smart appearance.** To keep your car looking smart and new should be a matter of pride to the driver or owner. It is our object to provide you with paintwork which not only looks good and has a sparkling lustre but is most durable. A chemical treatment protects the body against rust and anchors the synthetic resin enamel to the metal.

Even the best paint work requires regular care. You will realise the importance of this if you consider that the paint is exposed to sunshine, rain, dust and dirt.

**Wash** your new car frequently during the first weeks as this is good for the finish. When washing you require a soft sponge for the body, a soft brush for the wheels, a sturdy, long-handled brush for the chassis, and plenty of water.

The chassis and underneath part of the body should first be flushed with water to soak off the dirt, and afterwards a brush should be used.

Spray the exterior finish of body and wheels evenly with water until dirt is soaked off. Do not allow a powerful jet of water to hit the painted surface. Using plenty of clear water, remove dirt with a sponge. Clean the sponge at short intervals to avoid scratching the paint work.

There are many proved auto soaps and detergents available which greatly facilitate this job. Do not buy just any product, let your VW dealer advise you. It is of utmost importance to rinse the body thoroughly with water to ensure that no traces of the detergent remain on the body. After washing, dry off with a clean chamois to prevent water spots from forming.

**Preservation (Waxing)** should be carried out for the first time after approximately 8 to 10 weeks and afterwards, if possible, at regular intervals of between 6 and 8 weeks. Waxing means to restore to the finish certain substances it has lost by exposure to the weather. At the same time a protective water-repellent coat of wax is applied to the body.

The "Genuine VW Preservative" (L 190) was specially produced for the Volkswagen and is obtainable from every VW dealer. After washing and drying the car thoroughly, apply the preservative thinly with a soft cloth. Let it dry for approximately 20 minutes and then rub it down with polishing cotton or a soft polishing cloth until iridescent colours can no longer be seen when you are standing at an angle to the polished area.

Do not forget to wax the car after each detergent washing as the intensive cleansing properties of the chemical detergent will partially dissolve the protective film of wax.

**Polishing.** You should polish your car only if its appearance has been affected as a result of insufficient care, or if the application of the preservative no longer restores the original lustre. Avoid the use of abrasives or chemically harmful products.

A special polish for the synthetic-resin enamel finish is also available from your Volkswagen dealer under the designation "Genuine VW Polishing Fluid" (L 170). Prior to applying the polish, the car must be washed and dried carefully. The polish should be applied with a soft clean cloth or polishing cotton – use a straight horizontal or vertical motion rather than a circular motion. After rubbing for some time you will notice a slight resistance, which indicates that the ingredients of the polish have settled in the finish and that the solvent has evaporated. Now take clean polishing cotton and rub the body down until the high polish is restored.

To prevent the polishing fluid from drying off prematurely, do not apply it on too large an area of the body at a time. A subsequent application of the preservative and your efforts will be rewarded with a long-lasting shine.

---

**Never wash, wax or polish the car in sunlight.**

---

**Tar spots.** Tar splashes have a tendency to corrode the finish within a short time and should be removed as soon as possible with Genuine VW Preservative.

On the road you usually have nothing at your disposal but fuel. Kerosene or turpentine may also be used. After this, the treated spots should be washed with a mild, luke warm detergent solution, and rinsed, in order to remove traces of the cleansing agent.

**Insects** are caught, especially in hot weather, on the front of the car and on the windshield. Insects should not be allowed to remain on the paint finish for long and should be removed with water and a sponge. Once baked on they can only be removed with luke warm detergent solution.

**Parking under trees.** Vehicles which are parked under trees for long periods in summer are often found to be covered with spots. These spots can be removed fairly easily with luke warm detergent solution if the treatment is not delayed too long. It is advisable to apply a coat of preservative afterwards.

**Chrome parts** should be treated with "Genuine VW Chrome Cleaner Chromlin" when dry. Apply Chromlin thinly and allow to dry for 10 minutes before polishing with a dry cloth.

**Cloth upholstery.** If a vacuum cleaner is not available, the upholstery should be cleaned thoroughly with a brush. Stains can generally be removed with luke warm soap suds. Grease and oil stains are removed with cleaning paste or cleaning fluid. Do not pour the cleaning fluid directly on the upholstery as otherwise rings will form. Moisten a clean, uncoloured cloth with the fluid and rub with a circular motion, starting outside the spot and working inwards.

**Leatherette** can best be cleaned with a soft cloth or soft brush. If very dirty, use suds of any luke warm detergent solution or a dry foam cleaner.

If the seating surfaces and front sides of the backrests are also made of leatherette, the surfaces may only be cleaned with a dry foam cleaner. They are made of an air-permeable leatherette and liquid cleaners would immediately penetrate into the textile backing.

Grease and paint spots should be wiped off before they dry on. Soaked-in spots can be removed by wiping carefully with a rag moistened with fuel or alcohol. Spots caused by shoe polish can be removed with turpentine. Use these agents carefully and sparingly as otherwise they tend to dissolve the dust-repellent finish of the leatherette. Solvents such as trichlorethylene or paint thinner must not be used for cleaning.

After cleaning, the leatherette should be dried thoroughly with a soft cloth. So-called preservatives are not suitable for leatherette because they do not soak into the material and will merely collect dust and make clothing dirty.

**The windows** can be cleaned best with a clean sponge and warm water. A glass cleaning solution should only be added to the water in exceptional cases as these solutions tend to affect the paint preservative. Always use a special clean leather to dry the windows. This leather must not be used for the paintwork in any circumstances as most paint cleaners and polishes contain ingredients which will cause unpleasant streaks to appear on the windshield when it rains, even if only the smallest trace is present.

These streaks can only be removed with a good windshield cleaner and a lot of care. Do not forget the windshield wiper blades.

**Door and window weatherstrips.** It is important to keep the rubber parts undamaged and supple to ensure perfect sealing. To retain the original flexibility of the rubber, these parts should be coated occasionally with talcum powder.

**Airing the interior.** If the car is left in your garage for a long period, it must be aired regularly. Permit air to circulate freely by opening the doors and lowering the windows to prevent the formation of mould and damp stains.

## Lubrication Service

To lubricate correctly means to lubricate carefully and at the prescribed intervals. Therefore, do not omit to have the lubrication service carried out at regular intervals. A lubrication chart can be found on page 61 indicating the correct mileages at which to lubricate.

The Service Booklet makes it possible for you to have your car lubricated at our authorized workshops by skilled personnel, at the lowest cost and in a minimum of time. You really cannot afford to miss this opportunity.

### Engine

Regular oil changes are necessary even if the very best branded oils are used. Dirty oil in your engine simply means increased wear and a shorter service life.

The oil is drained, when warm, by removing the plug in the oil strainer cover plate. Flushing of the engine is unnecessary. However, the oil strainer must be removed and cleaned at every oil change. The two gaskets and the washers for the cap nuts must be renewed each time. The engine is refilled with 2.5 liters of HD oil (5.3 US pints/4.4 Imp. pints).

Draining the engine oil.

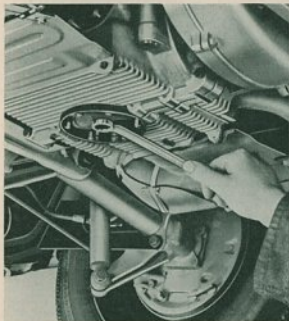

Cleaning the oil strainer.

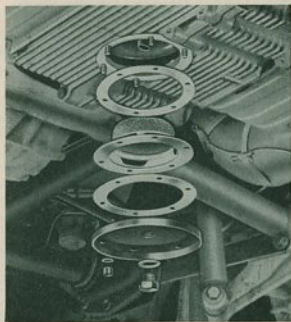



It is superfluous and uneconomical under normal operating conditions to change the oil at shorter intervals than every 5,000 km (3,000 miles). We recommend oil changes at more frequent periods, only in winter if you drive mainly short distances or in city traffic and only cover a few hundred miles a month under these conditions.

### **Types of lubricant**

HD oils are prescribed for the engine lubrication. HD oil is an oil with proved oxidation stability, bearing corrosion preventive properties and detergent-dispersant characteristics which tend to hold in suspension foreign contaminants which would normally deposit on engine parts. These foreign contaminants will drain out with the oil at the periodical oil changes. The detergent properties of HD oil will make the fresh oil darker after a short time of operation. This is quite natural and there is no reason whatsoever to change the oil earlier than called for in the Lubrication Chart.

### **Some more information on oils**

The quality of branded oils is such that the choice is left to your discretion. In cases of doubt, your authorized VW dealer will be glad to assist you. We recommend that you select "your" oil after the first 500 km (300 miles) and stick to it at all future oil changes.

The viscosity grades of the different oils are shown by the designations SAE 30, SAE 10 W and so on. The viscosity of a lubricant is an indication of its resistance to flow at given temperature. The chart on page 61 shows you which oil to select to suit the existing temperature.

Temporary deviations in the temperatures for the various viscosity grades are of no importance. It is permissible to mix oils of different viscosity grades when it is necessary to add oil between the oil changes, and the outside temperature no longer corresponds to the viscosity grade of the oil in the engine. It is, however, essential that the same brand of oil be used.

In some countries the API classification is applied (API = American Petroleum Institute). According to this classification, the HD oils suitable for the VW engine are referred to as "For Service MS".

### Transmission

The transmission and differential gears are combined in the transmission case and both lubricated with hypoid oil. The oil should be up to the edge of the filler hole.

At oil changes — at 500 km (300 miles) and then again at 50,000 km (30,000 miles) — the old oil is drained by removing both the magnetic drain plugs while the oil is at operating temperature. The magnetic drain plugs should be thoroughly cleaned. The transmission is filled with 2.5 litres (5.3 US pints/4.4 Imp. pints) of branded hypoid oil.

Additives should not be used with hypoid oils.

Draining the transmission oil.

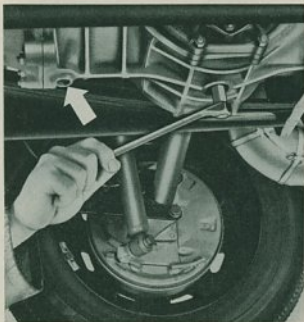

Filling with transmission oil.

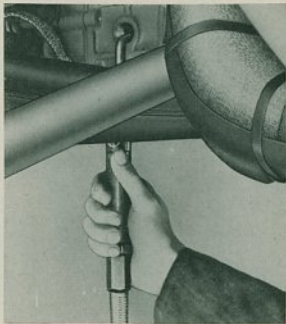

### Chassis

The front axle bearing points can only be lubricated properly when the axle is free of load, that is, with the vehicle lifted.

The front axle has four grease fittings which must be lubricated every 10,000 km (6,000 miles).

Prior to lubrication, the grease fittings should be cleaned thoroughly with a cloth to prevent dirt from being forced into the bearings.

Please check the dust seals on the maintenance-free ball joints and tie rod ends for damage and security at every lubrication

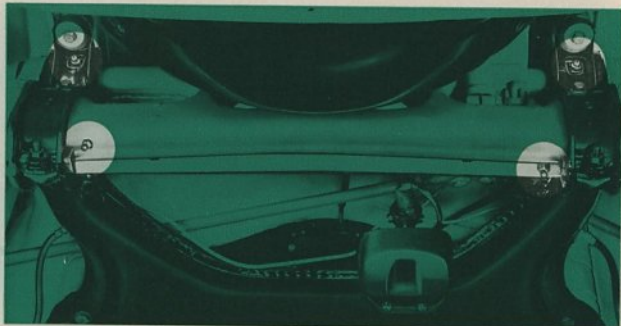



service. Damaged dust seals should be replaced immediately if possible.

Oil and grease must be kept off the tires and brake hoses. Even small quantities should be wiped off immediately.

If you drive less than 10,000 km (6,000 miles) in the year, the front axle should be lubricated once a year.

Annually at the beginning of the cold season the cables for the accelerator, clutch and heating as well as the clutch cable adjusting nut should be checked and, if necessary, cleaned and lubricated.

### **The front wheel bearings**

are packed with grease at the factory. The caps on the front wheels hubs must be free from grease.

Every 50,000 km (30,000 miles) the bearings should be carefully cleaned and packed with the grease prescribed under "Lubricants".

The brake discs must be removed for this purpose. Finally the front wheel bearings must be adjusted. In order to avoid damage, to the bearings, this operation should, if possible, be carried out in a VW workshop only.

### **Doors and hoods**

The door hinges should be oiled at every lubrication service or, better still, once a month.

The door lock cylinder is lubricated with graphite. It is sufficient to dip the key into the graphite and to move it back and forth several times in the lock.

The door lock striker plates should be very lightly greased.

The hood hinges are oiled, the hood locks lightly greased.

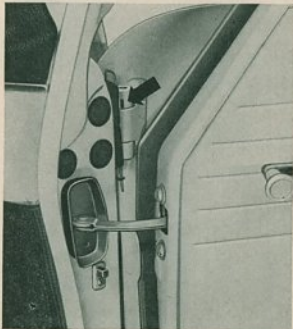

## Maintenance Service

The Volkswagen Service Organization has made available for you an extensive network of authorized VW workshops staffed with well trained and experienced personnel, and equipped with all the special tools required to service your car. If ever you should need service when touring and away from home, look for the well-known VW Service Sign. Here you will receive prompt and expert assistance.

In case you cannot get to an authorized VW workshop quickly and have to carry out small repairs yourself we have listed here the most important tasks which are normally dealt with during the maintenance checks. However, it is important that repair jobs which are beyond your capacity should be performed by the nearest VW workshop. Your car is then in capable hands. This will save you time, inconvenience, and money.

### Checking the V-belt

The belt should be checked at regular intervals for tension and wear. When pressed with the thumb it should yield approximately 1.5 cm (.6") and should not show signs of excessive wear.

The intake housing cover is removed when adjusting or replacing the belt. Now loosen the nut on the generator pulley with a 21 and 27 mm wrench and remove the rear half of the generator pulley. The belt is adjusted by removing or inserting spacer washers between the two pulley halves. Removing spacer washers increases the tension and inserting washers reduces it. The belt should not be too slack, nor should it be too tight.

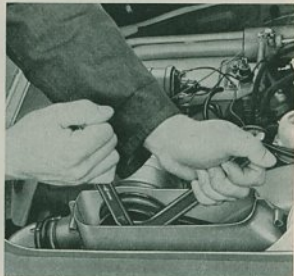

## Checking air cleaner

The oil bath air cleaner should be checked every 10,000 km (6,000 miles).

All the dust present in the air drawn in by the engine is retained by the filter insert in the upper part of the air cleaner and washed out when the vehicle is in motion by the oil in the lower part of the cleaner. In time, this causes a layer of sludge to form at the bottom of the lower part. If the cleaner check reveals that there is only 4–5 mm (.16"–.2") of oil above the sludge layer, the lower part should be carefully cleaned and filled with fresh oil. The top part does not need cleaning. However, if the filter insert has become so dirty due to overdue cleaning or oil shortage that the air inlet holes on the underside are partly blocked, the encrusted dirt should be removed, preferably with a small piece of wood.

A dirty filter insert not only reduces the engine output, it can also cause premature wear in the engine. If the local conditions are such that the vehicle is frequently driven over very dusty roads it is advisable to clean the air cleaner more often.

The warm air control flap should be checked each time for freedom of movement. This flap regulates the flow of warm air to the carburetor in conjunction with the speed of the engine.

## Servicing air cleaner

Loosen clip on air cleaner intake elbow and pull bellows off elbow.

Pull crankcase breather hose off air cleaner. Remove clip at carburetor elbow.

Remove air cleaner securing screw completely.

Take air cleaner off and disassemble. Never lay the upper part down with the filter element upwards.

Clean the lower part thoroughly and fill to the mark with fresh SAE 20 engine oil.

When installing the air cleaner, ensure that the carburetor elbow fits properly and that the bellows fits tightly on the air cleaner intake elbow.



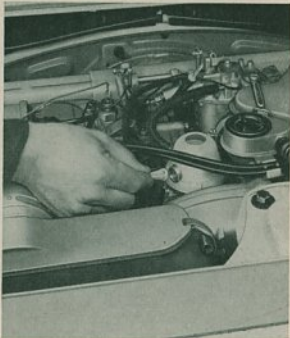

### **Cleaning the fuel pump filter**

The fuel pump filter prevents foreign matter and water from entering the carburetor. It should be removed and cleaned at the prescribed intervals.

Pull suction hose off fuel pump and seal it.

Remove hexagon plug and take filter out.

Wash filter thoroughly in benzine. When installing the filter, do not forget the gasket for the plug.

### **Ignition timing**

Particular attention must be paid to correct ignition timing. In many cases poor performance, high fuel consumption and even damage to the engine can be the result of incorrect ignition setting. The ignition must not be advanced arbitrarily.

Before setting the ignition timing, the breaker contact point gap must be checked. With the breaker arm fully lifted the clearance should be 0.4 mm (0.16"). The initial spark advance must be set to 10° before top dead centre.

The ignition timing must only be set with the engine cold or when it is slightly warm.

### **Cleaning contact points**

A certain amount of material movement takes place between the contact breaker points in the course of time. This creates a small build-up and a crater on the contact surfaces of the points but does not normally affect the ignition system. It is important, however, to ensure that the points are always clean and free of oil and grease. The best way to clean the points is to pull a piece of cardboard between them while pressing them lightly together. Badly burned points should be replaced.



### Lubricating ignition distributor

The breaker arm fiber block in the ignition distributor should always be lightly greased with lithium grease. Every 10,000 km (6,000 miles) check whether this location must be cleaned and provided with new grease. Only a very small amount of grease should be used and none of it must come in contact with the breaker points as otherwise the ignition will be affected.



### Adjusting contact points

Remove distributor cap and rotor.

Remove air intake housing cover and crank the engine by means of the generator until the contact arm rests on the highest point of the cam lobe.

Loosen the breaker point locking screw.

Insert a screwdriver between the two lugs on the contact plate and the slot in the point carrier and adjust the gap to "a" = 0.4 mm (.016").

Tighten locking screw and install rotor.

After the contact points have been adjusted, the ignition timing must be reset.

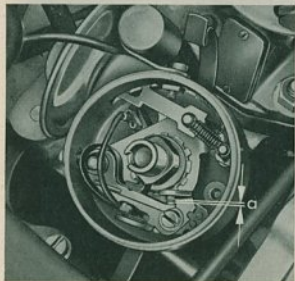



## Setting the ignition timing



Turn the engine clockwise until the center mark on the crankshaft pulley lines up with the adjusting surface on the fan housing and the distributor rotor arm is in line with the number 1 cylinder mark on rim of distributor.

Loosen clamp screw on distributor retainer.

Connect a 6 Volt test lamp to terminal 1 of the ignition coil and to ground.

Switch on ignition.

Rotate the distributor clockwise until the contact points are closed and then slowly

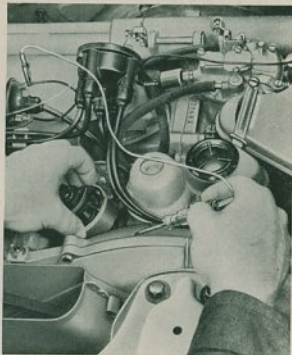

anti-clockwise until the contact points just start to open and the test lamp comes on.

Tighten the clamping screw of distributor retainer.

Install distributor cap.

The ignition is correctly set if on cranking the engine slowly clockwise, the test lamp comes on when the center mark on the crankshaft pulley is in line with the adjusting surface on the fan housing. Beforehand, the engine should be turned back anti-clockwise approximately a quarter of a revolution to take up the play in the distributor drive.

## Checking the spark plugs

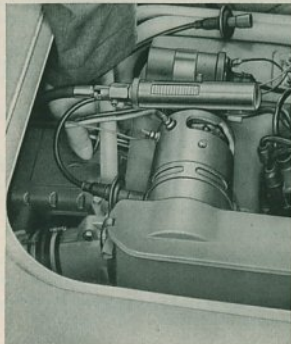
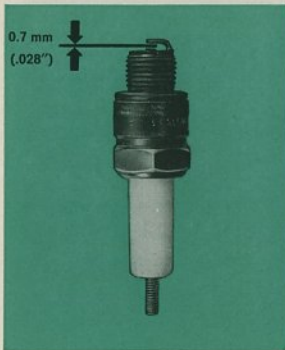
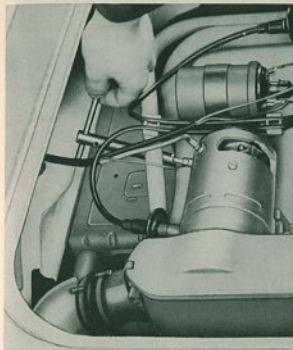

The appearance of the electrodes and insulation gives valuable information on the adjustment and condition of the engine:

- medium grey — correct carburetor adjustment and proper performance of spark plug
- black — mixture too rich
- light grey — mixture too lean
- oiled up — failure of spark plug or piston ring blow-by

The spark plugs have an average service life of approximately 15,000 km (10,000 miles) and should, therefore, be replaced in time. To prevent any breakdowns in the ignition

system, the spark plugs should be removed every 10,000 km (6,000 miles) and checked. Deposits can easily be removed with a brush and a chip of wood. Moreover, the insulator should be clean and dry on the outside in order to avoid short circuit and tracking. If necessary, adjust the spark plug gap which should be 0.7 mm (.028").

Do not omit the gasket when screwing in the spark plug. Do not overtighten the spark plugs.

## Checking compression

The compression is checked by inserting a suitable gauge into the spark plug holes, when the engine is warm. All the plugs must be removed and the air cleaner taken off. The accelerator pedal is then fully depressed and the engine turned over with the starter until the gauge reading shows no further change. The pressure should be at least 7 kg/cm<sup>2</sup> (100 psi). It is important that only a good accurate instrument is used and a good seal obtained between instrument and spark plug seats.

## Adjusting the valves

The valves must only be adjusted when the engine is cold or slightly warm. The valve clearance for the intake and the exhaust valves is 0.10 mm (.004").

When adjusting, both valves must be closed, i. e. the piston of the cylinder concerned must be at T.D.C. on the compression stroke. The arrangement of the cylinders can be seen by the numbers 1 to 4 on the engine cover plates. Valve adjustment is carried out in the following sequence: cylinders 1, 2, 3, 4.

Remove intake housing cover.

Remove distributor cap.

Crank the engine until the rotor arm points to the No. 1 cylinder mark on the rim of the distributor.

Remove cylinder head cover.

Loosen the adjusting screw lock nuts for the valves of No. 1 cylinder.

Adjust valve clearance with a feeler gauge.

Hold the adjusting screws and tighten the lock nuts.

To adjust the valves for cylinders No. 2, 3 and 4, the engine is turned further anti-clockwise until the rotor arm is 90° offset each time.

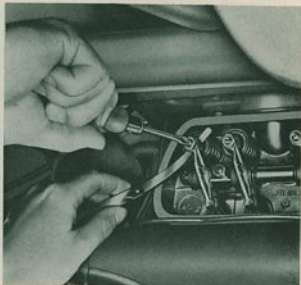

### Adjusting the carburetor

Each carburetor is checked at the factory and adjusted to the engine. Special knowledge and experience is required for checking and adjusting the carburetor with automatic choke and for carrying out repairs on the accelerator pump. For this reason, these operations should only be carried out by a VW workshop. Do not alter the adjustment by replacing the jets by other than the prescribed sizes. This would be detrimental under normal operating conditions and is not permissible.

Only the idling speed may require occasional readjustment. The adjustment must be carried out when the engine is at operating temperature:

Turn the idling adjusting screw until an idling speed of about 550 rpm has been attained (1).

Turn the volume control screw clockwise until the engine speed begins to drop. Then give it a  $\frac{1}{4}$  to  $\frac{1}{2}$  of a turn in an anti-clockwise direction (2).

Re-adjust the idling adjusting screw (1).

The adjustment is correct if the engine does not stall when the throttle is either suddenly opened or shut.

Poor idling may also be the result of damaged gaskets, loose intake manifold flanges, faulty ignition or leaky valves.

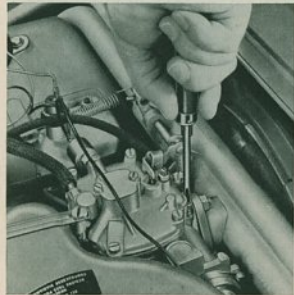
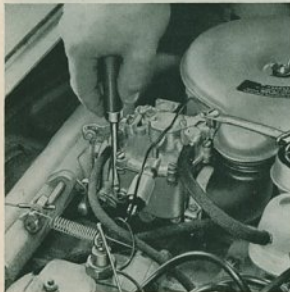



### Checking clutch pedal free-play

Easy gear shifting and complete transmission of engine performance to gears and wheels can only be guaranteed if the clutch is adjusted as specified.

Measured at the clutch pedal, this free-play should be between 10 and 20 mm / .4 and .8 in. (a). The clearance is adjusted with a wing nut on the cable end.

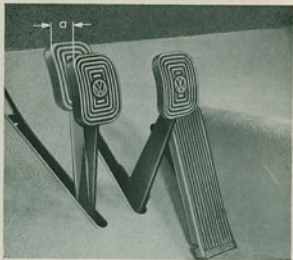

Ensure that the two lugs on the wing nut engage in the recesses in the clutch operating lever.

After adjusting, depress clutch pedal several times and recheck pedal free-play.

Lubricate bearing point between operating lever and wing nut with universal grease.

### Checking play of upper torsion arms

The upper torsion arms of the front axle are connected by the stabilizer and normally have hardly any noticeable axial play in their bearings. As result of wear in the course of time, this play will increase and must, therefore, be checked every 10,000 km (6,000 miles).

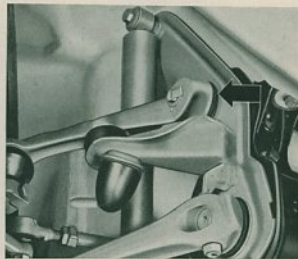

To check the play, rock one wheel and observe the torsion arms. If play is noticed at the upper torsion arms, they must be re-adjusted. This operation should be left to a VW workshop, as the camber and the toe-in of the front wheels have to be corrected afterwards. These operations require special experience and measuring devices which will be found in every workshop.



## Checking and adjusting brakes

The front axle is fitted with disc brakes and the rear axle with drum brakes. Every 10,000 km, the thickness of the brake linings should be checked. The thickness must not be less than 2 mm (.08") for the disc brakes and 2.5 mm (.1") for the drum brakes. The linings on the rear brakes can be checked through holes in the back plates. All the brake lines and connections should be checked for leakage, external damage and corrosion. Damaged brake lines must be replaced immediately.

The drum brakes must be adjusted as the linings wear and the pedal travel becomes excessive before the brakes take effect. The disc brake lining wear is taken up automatically every time the brake pedal is depressed.

If air gets into the hydraulic brake system the pedal will go down a long way and feel spongy. Before bleeding the brakes, check the level of the brake fluid in the reservoir near the spare wheel.

The reservoir should be at least three quarters full. Only use Genuine VW brake fluid or Lockheed fluid when topping up. Be careful not to spill the brake fluid as it will mark the paintwork.

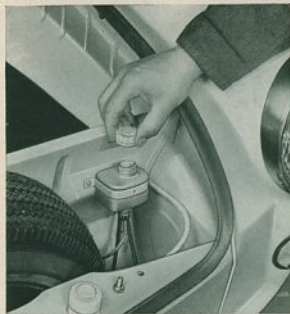

## The front wheel camber and toe-in

can only be checked properly in the workshop. When the vehicle is unladen, the camber should be  $1^{\circ}20' \pm 10'$  and the toe-in 4 to 6 mm (.16 to .24"). Excessive deviations from these values have a detrimental influence on the riding characteristics of the vehicle and on the service life of the tires.

## Checking the steering

The steering should not have an excessive amount of play in the straight ahead position. Moreover, the wheels must self-center after cornering.

To check the steering move the steering wheel lightly to and fro until resistance is felt in both directions. The steering gear is correctly adjusted if there is not more than 25 mm (1") play when measured at the steering wheel circumference.

Adjustments to the steering require special experience as well as special tools, and these operations should be carried out in a VW workshop only.

## Adjusting the drum brakes

The brake shoes are adjusted separately through holes in the back plates. The hand brake must be released fully when adjusting the shoes.

Before and after adjusting the brakes, depress the brake pedal hand once to centralize the shoes in the drums.

Lift vehicle.

Turn the adjusting nut in direction of arrow by levering it with a screwdriver until the brake lining contacts the drum lightly.

Repeat the process on the other adjusting nut. Note that the two adjusting nuts turn in opposite directions.

Back the nuts off 3 to 4 teeth until the wheel turn freely and seal the holes in the back plate carefully.

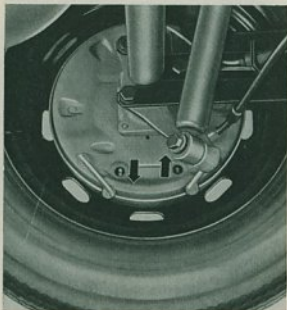

Adjust the brakes on the other wheel in the same way.

## Bleeding the brakes

When bleeding the brakes, always begin with the wheel which is farthest away from the master brake cylinder. The sequence for cars with left-hand drive is as follows: Right and left rear wheels, then the right front and finally the left front wheel.

Remove rubber cap of the bleeder valve and attach bleeder hose.

Submerge the free end of the hose in a glass container partially filled with brake fluid.

Repeat the above operations on the other wheels. Make sure that the brake fluid level in the reservoir is sufficient to ensure that air is not drawn in. After bleeding the complete system, check the brake fluid level and top up if necessary.

Depress and release the brake pedal quickly and repeatedly until a certain resistance indicates that pressure has been built up in the system.

Hold the pedal in lowest position.

Open bleeder valve  $\frac{1}{2}$  to 1 turn until brake fluid ceases to flow from bleeder hose and then close valve again with the pedal still right down.

Repeat this procedure on the same wheel until bubbles cease to appear at the end of the bleeder hose when the valve is opened. Tighten bleeder valve, take bleeder hose off and install dust cap.



## Adjusting hand brake

The hand brake is adjusted at the hand brake lever. The adjusting nuts are accessible through slots in the sides of the rubber boot.

Lift both rear wheels.

Unlock both nuts and tighten them uniformly until the rear wheels will just turn with the hand brake off.

Apply hand brake. At not later than the fourth notch it should be impossible to turn the wheels by hand. The compensating lever under the adjusting nuts should be horizontal when the hand brake is on. Lock the adjusting nuts again carefully.



## Checking the battery

Ready starting of the engine depends upon the condition of the battery. It should, therefore, be checked and maintained regularly. The battery cover can be removed by raising the rear seat and opening the battery snap fastener.

The acid level must always be slightly above the plates. The acid level has to be adjusted in accordance with the acid level mark. Depending on the type of battery, either the lower edge of the insert or the bar above the plates must just be covered. Losses by evaporation can be replenished by adding distilled water. Do not add acid unless some of the electrolyte has been spilled. If the acid level is too high it can boil over and cause damage. For this reason exercise care when topping up.

The battery should be checked with a cell tester. This is a voltmeter in parallel with a heavy resistance. The voltage of each cell should not fall below 1.6 Volts while the reading is being taken (10–15 seconds). Otherwise the cell is discharged or defective. The normal voltage is 2 Volts.

The battery poles should be cleaned with a clean cloth, or in the event of heavy corrosion, with a stiff brush. The battery poles and cable terminals should be coated with grease. Make sure that the battery is correctly grounded.

The state of charge of the battery can be checked with a hydrometer. The specific gravity of the acid will increase with the

charging of the battery. The gravity can be read from a scale.

Battery full charged	1.285 = 32 °Bé
Battery semi-charged	1.230 = 27 °Bé
Battery discharged	1.142 = 18 °Bé

When laying your vehicle up for a prolonged period, it is advisable to take the battery to a workshop for storage. A battery which is not in constant use will discharge itself in time and this can result in permanent damage to the plates if the battery is not checked about every 4 weeks and charged as necessary.

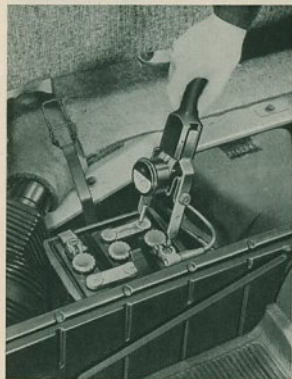

## Headlight adjustment

When adjusting the headlights, ensure that the tires are inflated to the correct pressures. If a headlight aiming device is not available proceed as follows:

### Sketch 1

a – 1260 mm (49.6")

b – Height of headlamp center from floor

c – Sedan 50 mm (2")  
Variant 375 kg 150 mm (6")  
Variant 465 kg 100 mm (4")

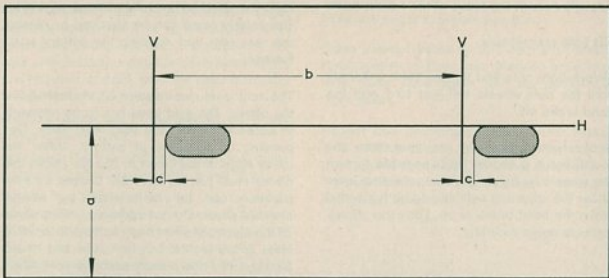

### Sketch 2

a – Height of headlamp center from floor

b – Distance between headlamps (49.6")

c – 2"

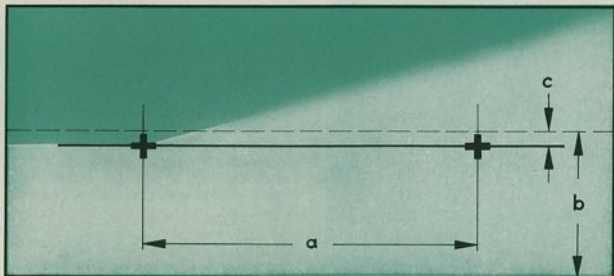



## 1 – Headlights with separate reflector and bulb

Position the vehicle on a level surface 5 m (16 ft. 5 ins.) away from a vertical wall. The rear seat must be loaded with one person or a weight of 70 kg (154 lbs.).

Draw two crosses with setting lines on the wall to the measurements in sketch 1. The longitudinal center line of the vehicle must be aligned exactly with the centre between the two crosses and at right angles to the wall.

Aim the headlights individually by turning the two slotted screws in the head lamp rim with the beams dimmed. Cover up the second headlight.

The headlights are correctly aimed when the light-dark border line is horizontal on the adjusting line to the left of the cross and the angle on the light-dark border line is exactly on the cross.

## 2 – Sealed-Beam Headlights

Position the vehicle on a level surface 7.6 m (25 ft.) away from a vertical wall. The drivers seat must be loaded with one person or a weight of 70 kg (154 lbs.).

Draw three setting lines on the wall to the measurements in sketch 2. The longitudinal center line of the vehicle must be aligned with the center between the two vertical lines and at right angles to the wall.

Loosen the screw in the center below the headlight and take the rim ring off.

Aim the headlights individually by turning the two aiming screws with low beams switched on. Cover up the second headlight.

The headlights are correctly aimed when the top edge of the high intensity zone is on the horizontal line H and the left edge is 2" to the right of the vertical line V.

## Headlight bulb replacement

Loosen the Philips screw at the bottom of the headlight rim and take out the lens and reflector unit.

Turn the cap to the left and take the holder out of the reflector.

Pull the connector off the bulb base and replace the bulb.

Hold the new bulb with a clean cloth or a paper serviette and not with the bare hand. The lug in the lamp holder must engage in the notch provided in the reflector.

Insert the cap so that the contact strip is located on the base of the parking slight bulb.

Check headlight settings.

A – Lateral aim





B - Vertical aim



### Replacement of Sealed-Beam units

Loosen screw in the center below the headlight and take the trim ring off.

Remove three screws in Sealed-Beam retaining ring and take ring off.

Take Sealed-Beam unit out of support ring and pull cable connector off.

When installing new Sealed-Beam units, ensure that the three glass lugs engage properly in the support ring.

Check headlight settings.

### Front turn indicator bulb replacement

Remove the slotted screws.

Remove housing with lens and seal and replace the bulb.

When installing, make sure that the seal is correctly seated.

### Stop/turn indicator or tail light bulb replacement

Remove two Phillips screws.

Take off lens.

Replace bulb.

Position of bulbs:

Upper - Turn indicator bulb

Center - Tail light bulb

Lower - Stop light bulb

When installing the lens, make sure that the seal is correctly seated. Do not overtighten the screws.

### Licence plate light bulb replacement

Open rear luggage compartment lid.

Remove both Phillips screws and take off lens with bulb holder.

Pull off bulb holder from lens.

Replace bulb.

When installing, make sure that the cable grommet is correctly seated.

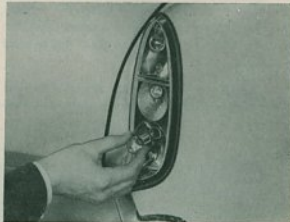

## Replacing fuses

The fuse box is located to the left under the instrument panel. When a fuse has blown, it is not sufficient merely to replace it by a new one. Inspect the electrical system for evidence of short circuits or other faults.

Under no circumstances use fuses which have been patched with tin foil or wire as they would be liable to cause severe damage elsewhere in the electrical system. We suggest that you always carry a few fuses, i. e. 16 Amp. fuses for the wiper motor and 8 Amp. fuses for all the other electrical fittings.

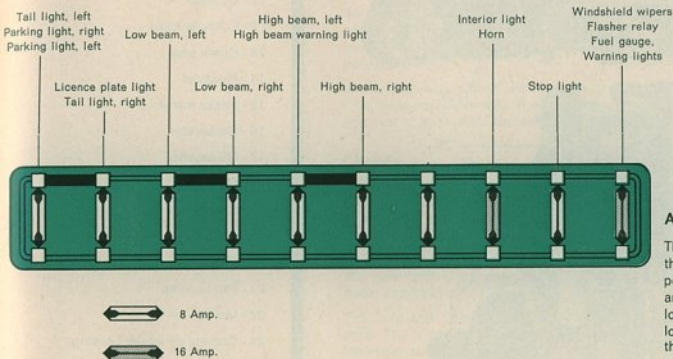
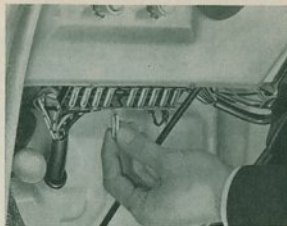

## Adjusting doors

There should be no noticeable play between the lock and the striker plate. It must be possible to open the doors easily without any signs of jamming. To adjust the door, loosen the three striker plate screws at the lock pillar and move the striker plate. Adjust the striker plate so that door and pillars are a flush fit. The striker plate is correctly adjusted if the housing on the door has the same clearance at top and bottom when sliding into the striker plate.

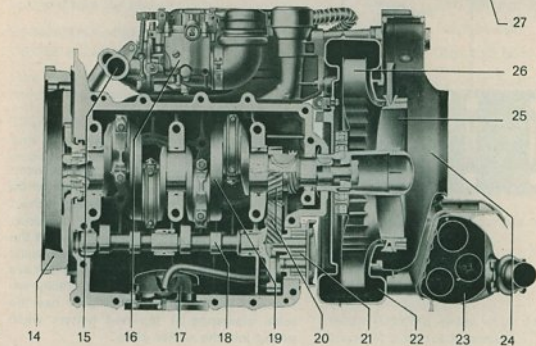
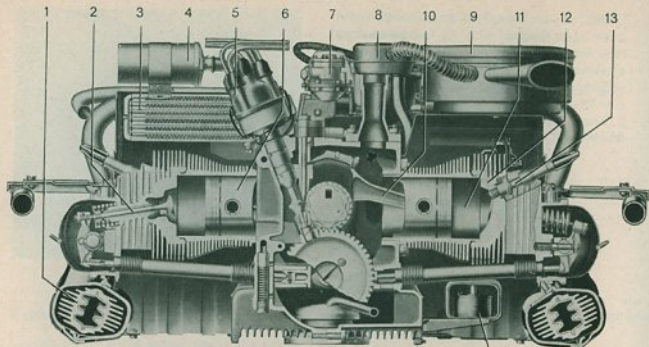

- 1 - Heat exchanger
- 2 - Valve
- 3 - Oil cooler
- 4 - Ignition coil
- 5 - Ignition distributor
- 6 - Piston
- 7 - Fuel pump
- 8 - Crankcase breather
- 9 - Connecting rod
- 10 - Oil bath air cleaner
- 11 - Cylinder
- 12 - Cylinder head
- 13 - Spark plug
- 14 - Flywheel
- 15 - Intake manifold
- 16 - Carburetor
- 17 - Oil strainer
- 18 - Camshaft
- 19 - Crankshaft
- 20 - Camshaft drive gears
- 21 - Oil pump
- 22 - Fan housing
- 23 - Muffler
- 24 - Cooling air intake housing
- 25 - Crankshaft pulley
- 26 - Fan
- 27 - Thermostat

## General Description

### Engine

The engine, located in the rear of the car, is attached by four bolts to the recessed flange of the rubber mounted transmission case. The crankcase is made of a light alloy. Two pairs of cylinders are horizontally opposed. Each pair has a common cylinder head made of light alloy. The overhead valves are located in the cylinder heads and are operated by the camshaft via cam followers, push rods and rocker arms. The short crankshaft runs in four bearings and has induction hardened journals. The camshaft is driven from it by means of helical gears. The connecting rods are provided with lead-bronze bearings. The pistons are of light alloy with steel inserts.

A side-draft carburetor with automatic choke and accelerator pump supplies the fuel-air mixture to the cylinders.

The oil pump of the pressure lubrication system is driven by the camshaft. The oil is drawn from the crankcase via a strainer and forced via an oil cooler to the lubrication points. When the oil is thick, an oil pressure relief valve enables the oil to flow direct to the lubrication points by by-passing the oil cooler.

The engine is cooled by a fan mounted on the crankshaft. The fan sucks in air through an opening in the cooling air intake housing and forces it through the fins of the cylinders. The flows of cooling air is regulated by a thermostat and this ensures a constant operating temperature.

The engine is equipped with battery ignition. The spark advance is controlled automatically by a vacuum mechanism. The generator is driven by a V belt. The generator pulley can be adjusted to alter the V belt tension.

### Chassis

The frame with its central tunnel is of pressed steel. It is forked at the front and supports the rubber mounted front axle. The engine-transmission unit is rubber mounted at three locations in a special sub-frame. The sub-frame with the engine and transmission unit is also rubber mounted at five locations to frame and body. A further rubber mounting supports the engine at the rear on the body.

The gear shift rod and fuel line and the guide tubes for the hand brake, clutch, accelerator pedal and fresh air heating cables pass through the tunnel.

The front axle beam is of pressed steel and is provided with bearing tubes for the torsion arms. The front wheels are individually suspended by two adjustable crossed torsion bars in the lower axle tube. A torsion bar extending between the two upper torsion arms serves as a stabilizer.

The roller type steering gear acts on the front wheels via divided tie rods. A steering damper ensures steering steadiness.



The rear axle is of the swinging half axle design. The rear wheels are independently sprung and have adjustable torsion bars. The Variant - 465 kg (1025 lbs.) - is provided with an additional torsion bar which is located diagonally above the rear axle.

Double-acting hydraulic shock absorbers in front and rear prevent excessive rebound.

### **Transmission and rear axle**

Power from the engine is transmitted to the gears via a dry single-plate clutch. The transmission case houses the transmission with four forward speeds, one reverse, and the differential.

All the forward gears are synchronized. The gears are helically cut to provide silent operation. The drive pinion and the ring gear are cut spirally. The two swinging rear axle shafts are flexibly supported in the differential.

### **Brakes**

The hydraulic foot brake system is fitted with disc brakes at the front and drums at the rear. The hand brake operates on the rear wheels via cables.

### **Body**

The two-door body is made of pressed steel and electrically welded. It is bolted to the frame. Both window doors can be lowered. Vent wings in the doors ensure draft-free ventilation. Both front seats can easily be adjusted while driving. The luggage compartments under the front and rear hoods are secured against theft when the car is locked. Both these locks are operated by cables. The fuel tank and spare wheel are located in the front luggage compartment. The engine compartment is accessible through the rear luggage compartment.

The Variant has four quarter windows. The load compartment is accessible through the rear door which is held open by torsion bars. By tipping the rear seat forward the load surface can be increased by more than half its size.

### **Heating system**

The fresh air drawn in by the fan is heated in heat exchangers. It is emitted through three defroster vents on the windshield, and two controllable outlets each in front and rear foot wells. The heating is regulated by two levers situated beside the driver's seat on the frame tunnel.

### **Ventilation**

The air for the ventilation is drawn in through openings in front of the windshield. Depending on the position of the three regulating levers on the instrument panel, the fresh air enters either through vents on the windshield or through outlets above foot level.



- 1 - Transmission shift lever
- 2 - Bonded rubber mounting
- 3 - Gearshift housing
- 4 - 4th gear train
- 5 - Gear carrier
- 6 - 3rd gear train
- 7 - 2nd gear train
- 8 - Main drive shaft, front
- 9 - 1st gear train
- 10 - Oil drain plugs
- 11 - Drive pinion
- 12 - Reverse gear
- 13 - Differential pinion
- 14 - Differential side gear
- 15 - Main drive shaft, rear
- 16 - Clutch release bearing
- 17 - Clutch operating shaft
- 18 - Reverse sliding gear
- 19 - Reverse shaft
- 20 - Oil filler plug
- 21 - Reverse drive gear
- 22 - Ring gear
- 23 - Rear axle shaft
- 24 - Fulcrum plates
- 25 - Differential housing

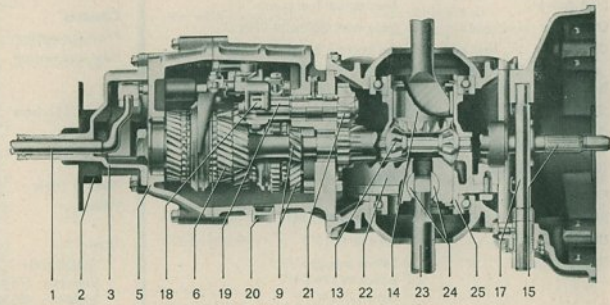
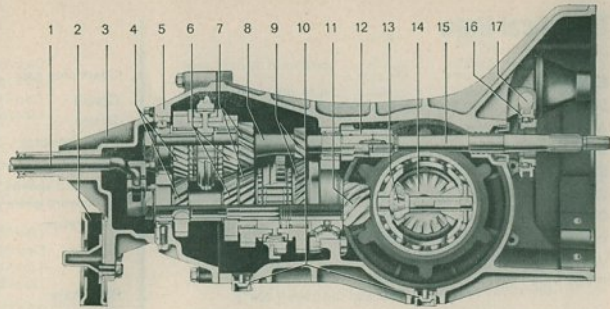

## Technical Data

### Engine

Design	4 cylinder, 4 stroke in rear of car
Arrangement of cylinders	Two pairs, horizontally opposed
Bore	83 mm (3.27")
Stroke	69 mm (2.72")
Capacity	1493 c. c. (91.09 cu. ins.)
Compression ratio	7.5 : 1
Valves	Overhead
Valve clearance with engine cold	Intake 0.10 mm (.004") Exhaust 0.10 mm (.004")
Maximum output (SAE)	54 bhp. at 4200 rpm.
Lubrication	Force feed by gear pump. Oil cooler
Oil capacity	2.5 liters (5.3 U.S. pints; 4.4 Imp. pints)
Fuel delivery	Mechanical fuel pump
Carburetor	Side draft Solex 32 PHN
Cooling	Air cooling by fan mounted on crankshaft, regulated by thermostat
Battery	6 Volt, 77 Amp.
Starting motor	6 Volt, 0.6 bhp.
Generator	6 Volt, 200 Watt at 2600 rpm., with regulator
Ignition distributor	Vacuum spark advance
Firing order	1-4-3-2
Initial spark advance	10° before T.D.C.
Breaker point gap	0.4 mm (.016")
Spark plugs	14 mm thread Bosch W 175 T 1 Beru 175/14

Champion L 85 y  
or plugs with similar values from  
other manufacturers

Spark plug gap . . . . . 0.7 mm (.028")

### Clutch

Design	Single plate, dry
Pedal free-play	10-20 mm (.4"-.8")

### Transmission

4 forward speeds, 1 reverse

All forward gears synchronized and silent.

Gear ratios	First	3.80 : 1	
	Second	2.06 : 1	Third 1.32 : 1
			Fourth 0.89 : 1
			Reverse 3.88 : 1

### Rear Axle

Power is transmitted through spiral drive pinion and ring gear, via two swinging half shafts to the rear wheels.

Ratio . . . . . 4.125 : 1

Oil capacity of transmission . . . 3.0 liters  
(6.3 U.S. pints; 5.3 Imp. pints)

### Chassis

Front suspension . . . . . 2 torsion bars, stabilizer

Rear suspension . . . . . 2 torsion bars  
Variant - 465 kg (1025 lbs. -  
additional torsion bar

Shock absorbers . . . . . Double-acting telescopic shock absorbers at front and rear

Steering . . . . . Roller type with divided tie rod, hydraulic steering damper

Turning circle . . . . . Approximately 11.1 m (36.5 ft.)

Wheels . . . . . Disc wheels with drop center rims  
4½ J x 15

### Tires:

Sedan and

Variant - 375 kg . . . . . 6.00-15 L, tubeless

Variant - 465 kg . . . . . 6.00-15 L 6 PR, tubeless

**Inflation pressure****Sedan:**

1 to 2 occupants	Front	1.1 kg/cm <sup>2</sup> (16 psi.)
	Rear	1.7 kg/cm <sup>2</sup> (24 psi.)
3 to 5 occupants	Front	1.2 kg/cm <sup>2</sup> (17 psi.)
	Rear	1.8 kg/cm <sup>2</sup> (26 psi.)

**Variant - 375 kg**

with half payload	Front	1.2 kg/cm <sup>2</sup> (17 psi.)
	Rear	1.8 kg/cm <sup>2</sup> (26 psi.)
with full payload	Front	1.2 kg/cm <sup>2</sup> (17 psi.)
	Rear	2.6 kg/cm <sup>2</sup> (37 psi.)

**Variant - 465 kg**

with half payload	Front	1.2 kg/cm <sup>2</sup> (17 psi.)
	Rear	1.8 kg/cm <sup>2</sup> (26 psi.)
with full payload	Front	1.2 kg/cm <sup>2</sup> (17 psi.)
	Rear	3.0 kg/cm <sup>2</sup> (43 psi.)

For long high speed motorway trips, the tire pressures should be increased by 0.2 kg/cm<sup>2</sup> (3 psi) at front and rear.

Wheelbase	2400 mm (94.5")
Track	Front 1310 mm (51.6")
	Rear 1346 mm (53.0")
Toe-in (unladen)	4 to 6 mm (0.16"-0.24")
Camber (unladen)	1°20' ± 10'
Foot brake	Hydraulic, disc front, drum rear
Hand brake	Mechanical, acting on rear wheels

**Dimensions and Weights**

	Sedan 375 kg	Variant 375 kg	Variant 465 kg
Length	4225 mm (168.3")	4225 mm (166.3")	4225 mm (166.3")
Width	1605 mm (63.2")	1605 mm (63.2")	1605 mm (63.2")
Height	1475 mm (58.1")	1465 mm (57.7")	1465 mm (57.7")
Ground clearance	149 mm (5.9")	144 mm (5.8")	144 mm (5.8")
Unladen weight	920 kg (2028 lbs.) <sup>1</sup>	1025 kg (2259 lbs.) <sup>2</sup>	1025 kg (2259 lbs.) <sup>2</sup>
Max. load	400 kg (881 lbs.)	375 kg (826 lbs.)	465 kg (1025 lbs.)
Max. total weight	1320 kg (2910 lbs.)	1400 kg (3086 lbs.)	1490 kg (3284 lbs.)

	Sedan 375 kg	Variant 375 kg	Variant 465 kg
Max. load on front axle	550 kg (1212 lbs.)	550 kg (1212 lbs.)	550 kg (1212 lbs.)
Max. load on rear axle	790 kg (1741 lbs.)	940 kg (2072 lbs.)	1020 kg (2248 lbs.)

<sup>1</sup> without driver

including driver

**Fuel**

Fuel consumption according to DIN 70,030 is approximately 8.4 liters per 100 km i.e. 28 mpg. US., 33.5 mpg. Imp. (Measured consumption plus 10% with half load and at a steady 3/4 of top speed 94 kph/58 mph).

Fuel rating	90 octane (Res. F 1)
Oil consumption	0.5-1.0 liters per 1000 km
	1.7-3.4 U.S. pints per 1000 miles
	1.4-2.8 Imp. pints per 1000 miles

**Refill Requirements**

Fuel tank	40 liters (10.6 U.S. galls.; 8.8 Imp. galls.)
Engine	2.5 liters of engine oil (5.3 U.S. pints; 4.4 Imp. pints)
Rear axle transmission	2.5 liters of hypoid oil (5.3 U.S. pints; 4.4 Imp. pints)
Brakes	0.25 liters of brake fluid (0.53 U.S. pint; 0.44 Imp. pint)
Oil bath air cleaner	Approx. 0.25 liters engine oil (0.53 U.S. pint; 0.44 Imp. pint)
Container for windshield washer	Approximately 1 liter of water (1 quart) Air pressure: 2.5 kg/cm <sup>2</sup> (36 psi.)

**Performance**

Maximum and cruising speed 125 kph (78 mph).

Climbing ability	Sedan <sup>3</sup>		Variant <sup>4</sup>	
	First gear	Second gear	375 kg 40.0%	465 kg 38.0%
<sup>3</sup> with 2 persons	Second gear	23.5%	20.0%	19.0%
	Third gear	14.0%	12.0%	11.5%
<sup>4</sup> half payload	Fourth gear	7.5%	6.5%	6.0%

**Bulb Chart**

V = Volt, W = Watt

Bulb for	Description according to German Standard DIN 72601	Part Number
Headlights	A 6 V 45/40 W	N 17 705 1
Parking lights	HL 6 V 4 W	N 17 717 1
Turn indicator front and rear, stop light	R 6 V 18 W	N 17 731 1

Bulb for	Description according to German Standard DIN 72601	Part Number
Tail lights	G 6 V 5 W	N 17 718 1
Licence plate light	G 6 V 10 W	N 17 719 1
Speedometer, fuel gauge, warning lights	J 6 V 1.2 W	N 17 722 1
Interior light	K 6 V 10 W	N 17 723 1

**Tools and Accessories**

- 1 Tool roll
- 1 Wheel cap removal tool
- 1 Combination pliers
- 1 Screwdriver with reversible blade for Phillips and slotted screws
- 1 Open end wrench 8×13 mm
- 1 Wrench for wheel mounting bolts, with bar (the bar is also used for the jack)
- 1 Spark plug socket with bar
- 1 Spare wheel
- 1 Jack



# Maintenance Chart

500 km 300 miles	10,000 km 6,000 miles	Operation	Every
		Check rear axle shaft nuts for tightness	
		Check tire pressures and tightness of wheel mounting bolts	
		Check V belt	10,000 km 6,000 miles
		Clean fuel pump filter	
		Check breaker points and replace if necessary, grease distributor, check breaker gap and ignition timing	
		Adjust valve clearance and fit new cylinder head cover gaskets	
		Clean spark plugs and check compression pressures	
		Check rubber valve for crankcase ventilation and preheating pipe valve, check exhaust system for damage	
		Check water drain flaps and air intake housing bellows	
		Check clutch pedal free-play	

500 km 300 miles	10,000 km 6,000 miles	Operation	Every
		Check dust seals on ball joints and tie rod ends and security of tie rods	10,000 km 6,000 miles
		Check and adjust axial play of upper torsion arms, camber and toe-in	
		Steering gear: Check and adjust play between roller and worm	
		Check tire wear, damage and inflation pressures	
		Check hydraulic brake system for leaks and damage Check brake fluid level and adjustment of hand and foot brakes	
		Check thickness of brake linings	
		Check operation of complete electrical system and headlight alignment	
		Road test vehicle, check foot and hand brake efficiency Check and adjust, idling and heating	
		Clean, grease, and adjust front wheel bearings	50,000 km 30,000 miles



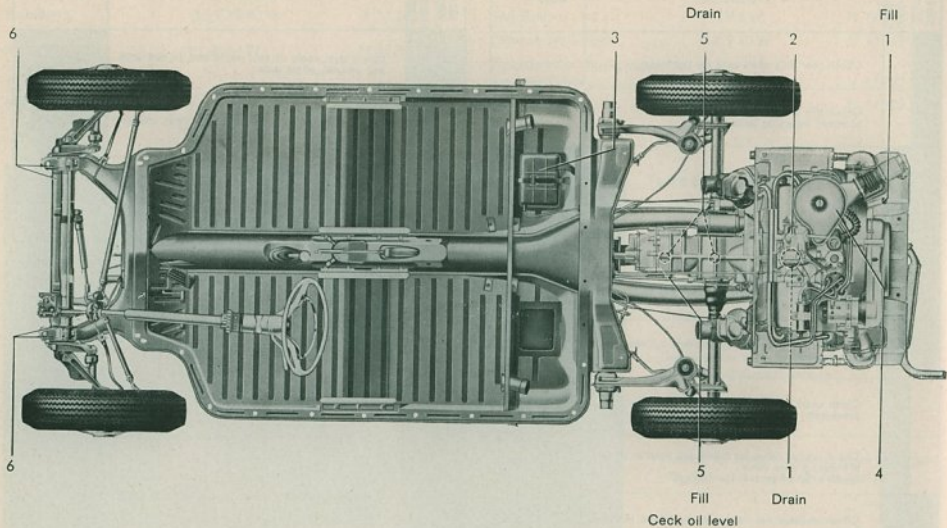

## Lubrication Chart

500 km 300 miles	5,000 km 3,000 miles	No.	Lubrication Points	Every
		1	Engine: Change oil, clean oil strainer Check visually for leaks	5,000 km 3,000 miles
		2	Lubricate carburetor linkage	
		3	Check battery, clean and grease terminals	
			Lubricate door hook locks and door hinges *	
		4	Check air cleaner, clean lower part if necessary	10,000 km 6,000 miles
		5	Rear axle: Check oil level Check visually for leaks	
		6	Front axle: Lubricate	
		5	Rear axle: Change oil, clean magnetic oil drain plugs Check visually for leaks	50,000 km 30,000 miles

\* at least every 3 months

## Lubricants

Lubricant	Lubrication Points	Specifications	
Engine oil (Branded HD oil for spark- ignition engines)	Engine Carburetor linkage Oil bath air cleaner Door hinges	Temperature °C °F	
		above 0 32	SAE 30
		below 0 32	SAE 10 W
		below -25 -13	SAE 5 W
Hypoid oil	Transmission	SAE 90 all the year *	
Universal grease	Door and hood locks	cold-resistant water-repellent high pressure grease	
Lithium grease	Front axle Front wheel bearings breaker arm fiber block in distributor	Multi-purpose grease	

\* SAE 80 all the year in countries with arctic climates

# Index

- Accelerator pedal ..... 5  
    - accelerating ..... 18
- Accessories ..... 61
- Air cleaner - cleaning ..... 37
- Ash tray ..... 11
- Battery - maintenance ..... 48  
    - care in winter ..... 25
- Body - airing ..... 30  
    - description ..... 54
- Brakes - adjusting ..... 46/47  
    - application ..... 23  
    - bleeding ..... 47  
    - care in winter ..... 25  
    - checking ..... 17/46  
    - description ..... 54
- Brake pedal ..... 5
- Breaking-in ..... 20
- Bulb chart ..... 56
- Carburetor adjusting ..... 43  
    - type ..... 56
- Camber ..... 57  
    - setting ..... 45
- Care of the car ..... 28
- Chassis - care in winter ..... 25  
    - description ..... 53  
    - lubrication ..... 34
- Chassis number ..... 4
- Chromium-plated parts - care ..... 30
- 62 Climbing ability ..... 57
- Clutch - design ..... 56  
    - pedal ..... 5  
    - pedal free-play ..... 44/56
- Cold weather hints ..... 24
- Compression ..... 41  
    - ratio of engine ..... 56
- Contact breaker points - setting ..... 39  
    - cleaning ..... 38
- Controls and instruments ..... 5
- Cooling of engine ..... 56
- Description - general ..... 53
- Dimensions - overall ..... 57
- Dimming - headlights ..... 8
- Dipstick ..... 17
- Doors ..... 6  
    - care of weather strips ..... 30  
    - adjusting ..... 51  
    - inside handle ..... 6  
    - lubrication points ..... 35  
    - locks frozen ..... 25
- Driving down-hill ..... 23
- Economy ..... 22
- Engine - compartment ..... 13  
    - description ..... 53  
    - design ..... 56  
    - lubrication (oil change) ..... 56  
    - number ..... 4  
    - oil change in winter ..... 24  
    - oil change  
        and refill requirements ..... 31  
    - oil strainer ..... 31  
    - speed ..... 57  
    - sectional view ..... 52  
    - technical data ..... 56  
    - type of oil ..... 32
- Firing order ..... 56
- Footbrake - adjusting ..... 46  
    - bleeding ..... 47  
    - description ..... 54
- Fresh air ventilation - operation ..... 10  
    - description ..... 54
- Front axle - description ..... 53  
    - lubrication ..... 34  
    - technical data ..... 56/57
- Front seats - adjustment ..... 7
- Front wheel bearings - lubrication ..... 35
- Fuel consumption ..... 57
- Fuel delivery ..... 56
- Fuel filter-cleaning ..... 38
- Fuel tank - capacity ..... 15/57  
    - reserve ..... 16
- Fuse box ..... 51
- Fuses - replacing ..... 51
- Gear lever ..... 5
- Gear shifting ..... 20  
    - on gradients ..... 21
- Generator ..... 56
- Ground clearance ..... 57
- Handbrake - adjusting ..... 47  
    - description ..... 54
- Headlights ..... 8  
    - aiming ..... 49  
    - changing bulb ..... 50
- Heating - description ..... 54  
    - operation ..... 24
- Horn ring ..... 5

Identification plate . . . . .	4	Ratios — rear axle . . . . .	56	Tires — M + S tires . . . . .	25
Idling — checking and adjusting . . . . .	43	— transmission . . . . .	56	— size . . . . .	56
Ignition — setting . . . . .	38	Rear axle — description . . . . .	54	— wear . . . . .	26
— distributor . . . . .	56	— technical data . . . . .	56	Toe-in . . . . .	57
— firing order . . . . .	56	— transmission of power . . . . .	56	— adjusting . . . . .	45
— lubrication of distributor . . . . .	39	Rear door — Variant . . . . .	14	Tools and accessories . . . . .	61
Instrument light . . . . .	9	Rear view mirror . . . . .	7	Torsion arms — checking play . . . . .	45
Interior light . . . . .	9	Reverse gear . . . . .	20	Towing . . . . .	23
Jack — application . . . . .	26/27			Track . . . . .	57
Keys . . . . .	6			Transmission — description . . . . .	54/56
Leatherette — care of . . . . .	30	Safety belts . . . . .	13	— oil change	
License plate light — replacing bulb . . . . .	50	Seat adjustment . . . . .	7	and capacity . . . . .	33/34
Lighting . . . . .	9	Shifting gears . . . . .	20	— sectional view . . . . .	55
Loading surface — Variant . . . . .	15	Shock absorbers — design . . . . .	56	— oil change in winter . . . . .	25
Load compartment light . . . . .	15	Snow chains . . . . .	25	Turn indicator bulb — replacement . . . . .	50
Lubricants . . . . .	59	Spare wheel . . . . .	26	Turn indicator switch . . . . .	9
Lubricant — additives . . . . .	34	Spark plugs — checking and cleaning . . . . .	41	Turning circle . . . . .	56
Lubrication service . . . . .	31	— gap . . . . .	25/41	Type of fuel . . . . .	16
Lubrication chart . . . . .	59	— removal . . . . .	41	Upholstery — care of cloth . . . . .	30
Luggage compartments . . . . .	12	Speedometer . . . . .	5	Valves — adjusting . . . . .	42
Maintenance service . . . . .	36	Speed ranges . . . . .	20	— arrangement . . . . .	56
Maintenance chart . . . . .	60	Spots — removal . . . . .	30	— clearance . . . . .	42/56
Maximum output . . . . .	56	Starting the engine . . . . .	18	Variant . . . . .	14
Maximum speed . . . . .	57	Starting motor . . . . .	56	V-belt — checking and adjusting . . . . .	36
Oil consumption . . . . .	57	Steering ignition lock . . . . .	18	Vent wing . . . . .	5
Oil level — engine . . . . .	16	Steering — adjusting . . . . .	45	Warning lights . . . . .	19
— dipstick . . . . .	17	— type . . . . .	56	Washing your car . . . . .	28
— specifications . . . . .	32	Stop light — bulb replacement . . . . .	50	Weights . . . . .	57
— transmission . . . . .	33	— checking . . . . .	17	Wheel base . . . . .	57
Operating instructions . . . . .	6	Sun vizor . . . . .	7	Wheels — balancing . . . . .	26
Paintwork — preservation . . . . .	28	Suspension — front . . . . .	56	— changing . . . . .	26
— polishing . . . . .	29	— rear . . . . .	56	— rim size . . . . .	56
Parking your car . . . . .	23	Tail light — replacing bulb . . . . .	50	Windows — cleaning . . . . .	30
Parking lights . . . . .	8	Technical data . . . . .	56	Window regulator handle . . . . .	5
Practical driving . . . . .	20	Tires — inflation pressure . . . . .	17/57	Window weather strips — care . . . . .	30
		— maintenance . . . . .	26	Windshield wiper switch . . . . .	8
				Windshield washer . . . . .	8



© 1965 Volkswagenwerk Aktiengesellschaft  
All rights reserved.

May not be reproduced or translated in  
whole or in part without the written consent  
of Volkswagenwerk AG.

Specifications subject to alteration  
without notice.





