

double

DER BERATER



Are you in the know?

INFORMATION FOR THE VW PARTS SERVICE · NO. 1. MARCH 1953

Genuine VW Spare Parts are the life blood of the VW Service

They are the alpha and omega of a good repair. That is why the experienced VW operator is constantly probing the demand for spares, what customers want and what they prefer.

For the information of those who have but recently joined the continuously growing VW Organisation, we wish to point out once more the advantages of exclusively using Genuine VW Spare Parts for repairs on Volkswagens.

It is worth thinking of the significant bearing VW Genuine Spares have on a good service, which in turn is the key factor in stepping up your sales. This makes it easy to realize the importance of an efficient Parts Service, while leading to the conclusion that Genuine VW Spare Parts contribute to a great extent to:

1. maintaining customer satisfaction,
2. maintaining the profitability of the business,
3. promoting the efficiency of the mechanics.

These statements are based on the fact that perfect repairs can be carried out only by means of Genuine VW Spare Parts. It is the qualities of these parts that make possible to meet the requirements of a perfect job, which the customer has the right to get at your service shop. The long service life of Genuine VW Parts saves the customer time, inconvenience, and money. Once a repair has been carried out, the VW owner can count upon another long period of trouble-free operation.

Good work depends on flawless parts and materials, and that is why the proven Genuine VW Spare Parts add up to the efficiency and skill of your mechanics, while increasing the profit margin.

What are Genuine VW Spare Parts?

This is easy to explain. They are factory engineered and inspected parts, delivered by the Parts Division of the Volkswagenwerk and described in the VW Spare Parts Lists and in all the other informative VW parts literature. The Volkswagenwerk guarantees these parts to be free from defects in material and workmanship. The sign "Genuine VW Spare Parts" indicates that the dealer is authorised to sell such parts and is an assurance for the VW owner that the parts offered and used in repairs are genuine VW products. This condition is to be met by our dealerships.

What are the special features and outstanding characteristics of Genuine VW Spare Parts and what makes them serve their purpose so well?

The

- material and
- workmanship

of Genuine VW Spare Parts are up to the rigid specifications which we require of our products. They are factory engineered and inspected.

This means:

1. Genuine VW Spare Parts are progressively improved on the basis of experience and practice.
2. Alert to the latest scientific discoveries, the Volkswagenwerk applies precision production methods that contribute to the quality of the parts.
3. Genuine VW Spare Parts meet the requirements under hard and trying conditions. They are subject to rigid inspection throughout the production process.
4. VW laboratories are continually testing the quality of raw materials, semi-finished and finished products.

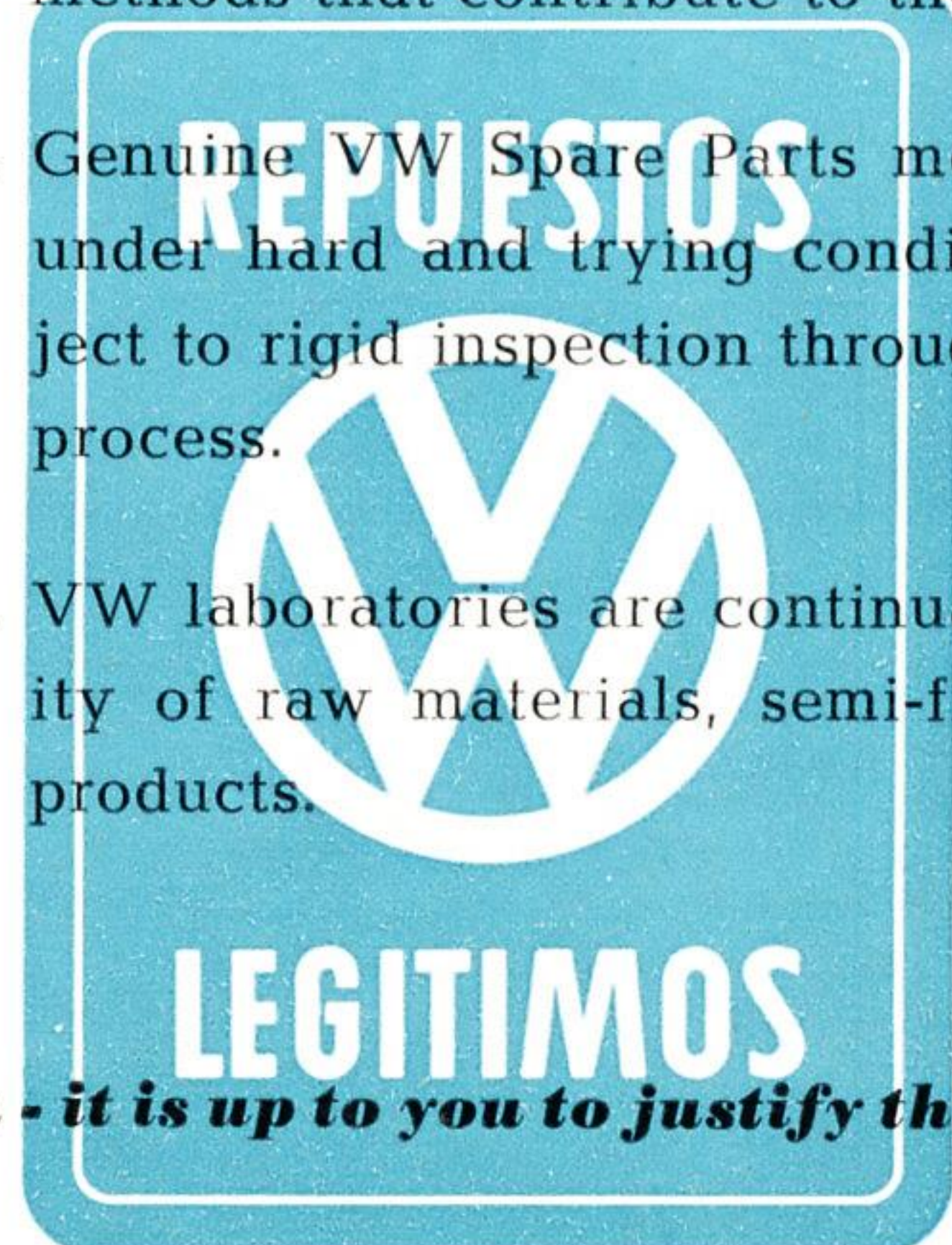
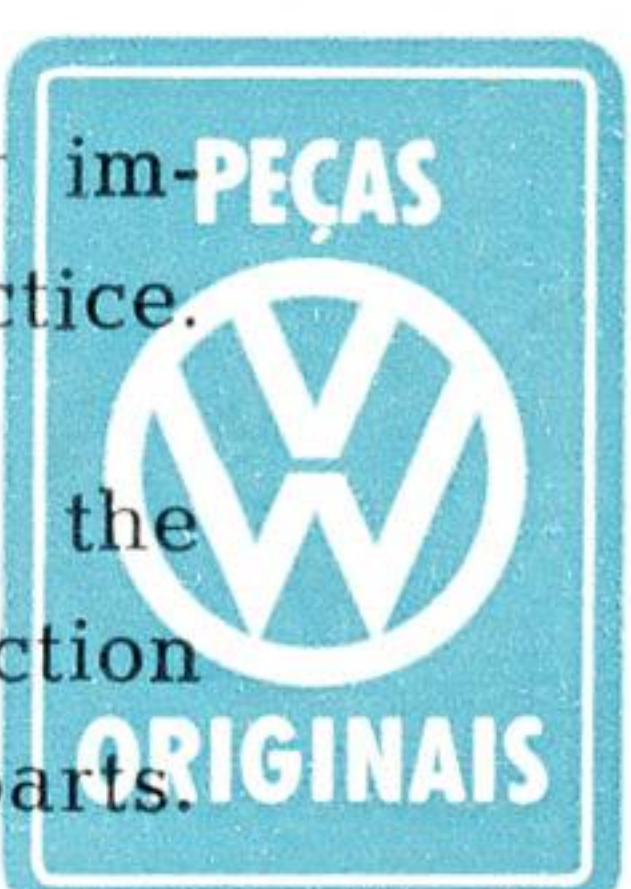

All over the world, VW owners have confidence in this sign - it is up to you to justify this confidence all year round.

5. The application of modern test methods, based on costly precision equipment that pays off in mass production only, allows the parts to be machined to very close tolerance limits.
6. Thanks to the large-scale mass production, Genuine VW Spare Parts are priceworthy, although the best material and a high standard process are applied.
7. Genuine VW Spare Parts guarantee safety and increase the life of the Volkswagen.
8. The use of Genuine VW Spare Parts will keep up the warranty under the given terms.

As will be gathered from the aforementioned points, the high quality of Genuine VW Spare Parts greatly adds up to the economy of Volkswagens. The business man who is accustomed to calculating profitability will find the utilitarian value of the Volkswagen to pay handsome dividends. To experts in the field of engineering, this is fully known, but also the greater part of the VW owners have no doubt about the necessity of using Genuine VW Spare Parts to obtain that result. They expect to get no inferior imitation parts from authorised VW dealers.

Therefore, it should be the foremost consideration of all dealers' parts departments to promptly supply customers with the desired VW Spare Parts at all times. This will keep up customer satisfaction and confidence in the VW Organisation and in the Volkswagen itself.

What are the tasks of the VW parts service staff?
Here they are in brief:

1. Constantly probing what customers want and what they prefer.
2. Ordering the right parts at the right time.
3. Being polite advisors to the customer.

The first requirement of selling parts is to know everything about them. The contact men in the parts department and in the sales and service departments should study the needs and interests of the customers to keep up a personal touch. This will point the way to success.

The Volkswagenwerk has made every effort to supply the necessary information through Parts Lists, Amendments, training courses, meetings, and personal advice passed on to the individual dealerships. Particular emphasis has been placed on the advantages of using Genuine VW Spare Parts only.

Due consideration is given by our design department to the possibility of subsequently installing improved parts. To give correct advice, the contact personnel should be fully informed about the modifications carried out. That is why henceforward special features of Genuine VW Spare Parts will be published in the form of illustrations and descriptive writing. The differences in the two versions of a modified part can thus easily be seen. If you consider such a comparison to be of help to you, we should be glad to receive any suggestions for future publications.

The motto of our success will be:

"Only use VW GENUINE SPARE PARTS".

VW Brake Back Plate

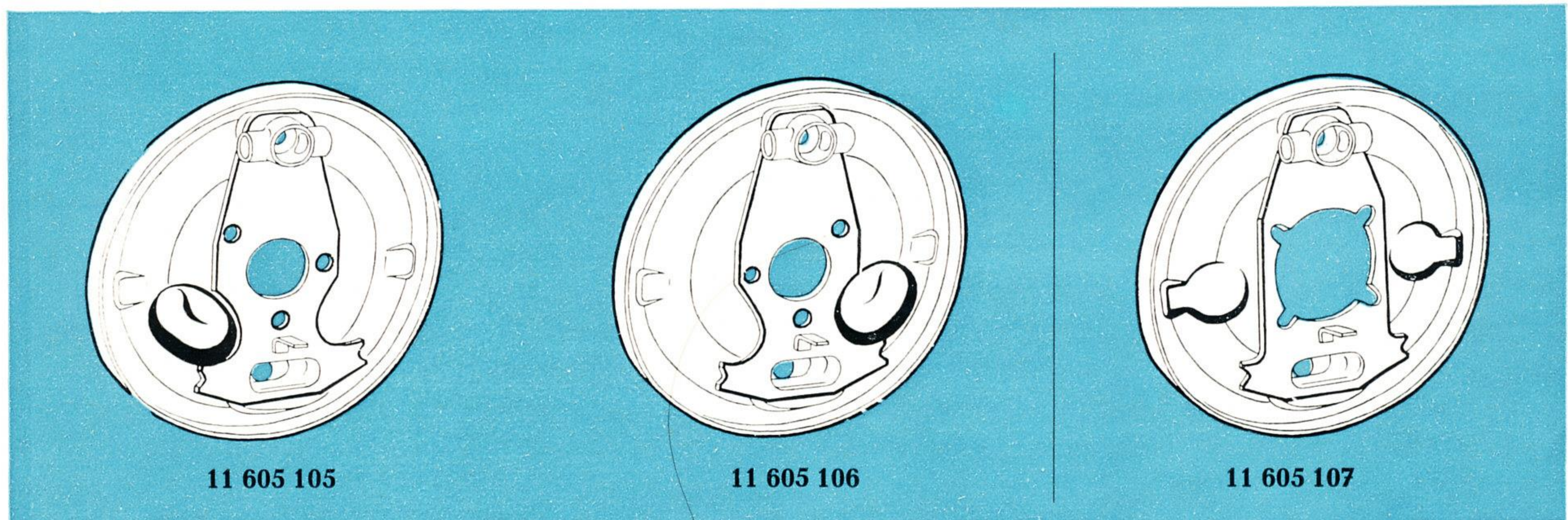

For a better comparison, all back plates are shown with the anchor block at the top. The rear back plates are shown in the position in which they are installed on the vehicle.

Mechanical Brake — Passenger Car (Type 1)

Part No. 11 605 105, front, left
 11 605 106, front, right
 11 605 107, rear left and right

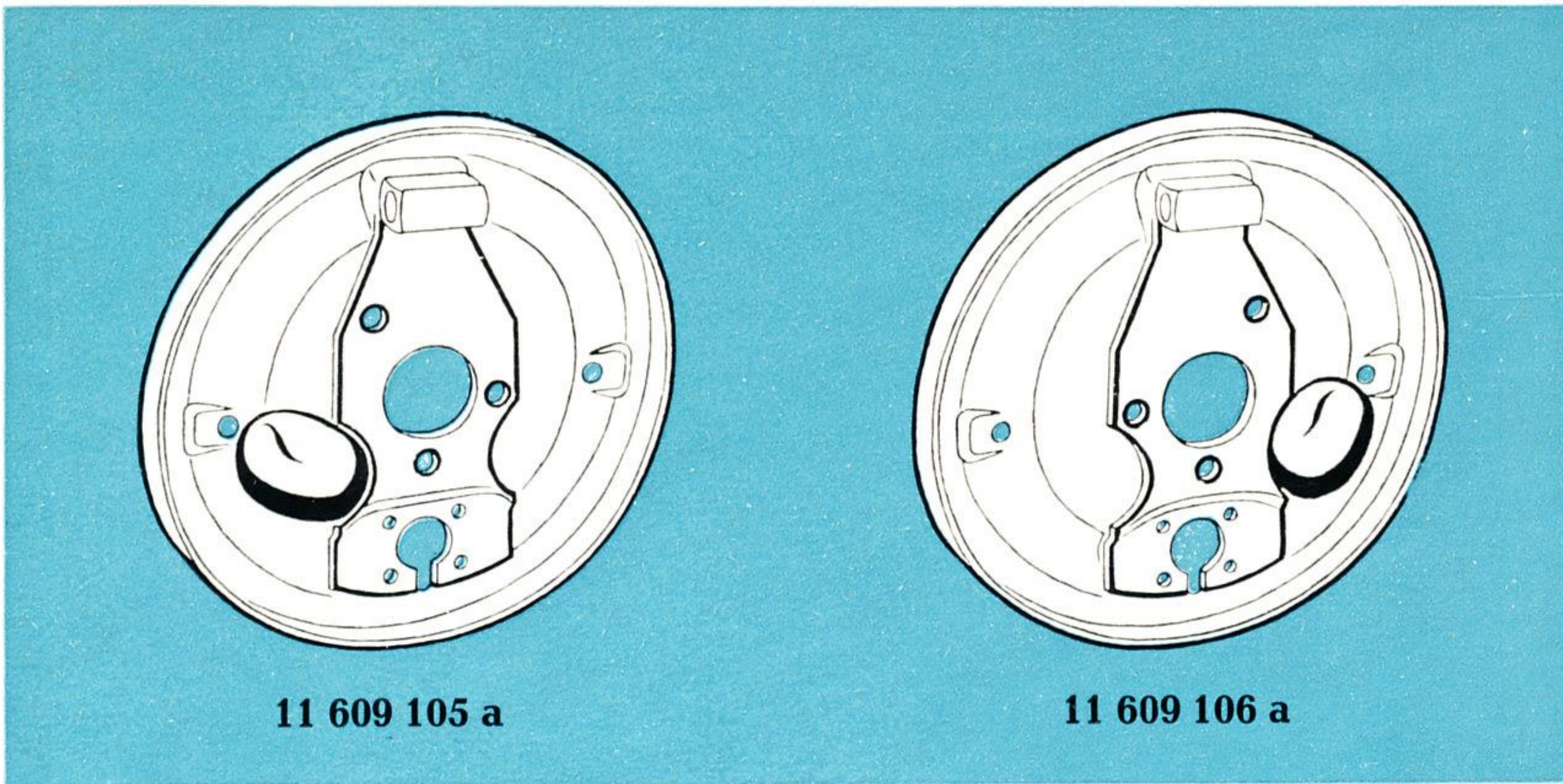

11 609 105 a

11 609 106 a

**Hydraulic Brake
Passenger Car (Type 1)**

Part Nos. 11 609 105 a
11 609 106 a
11 609 107 a
11 609 108 a

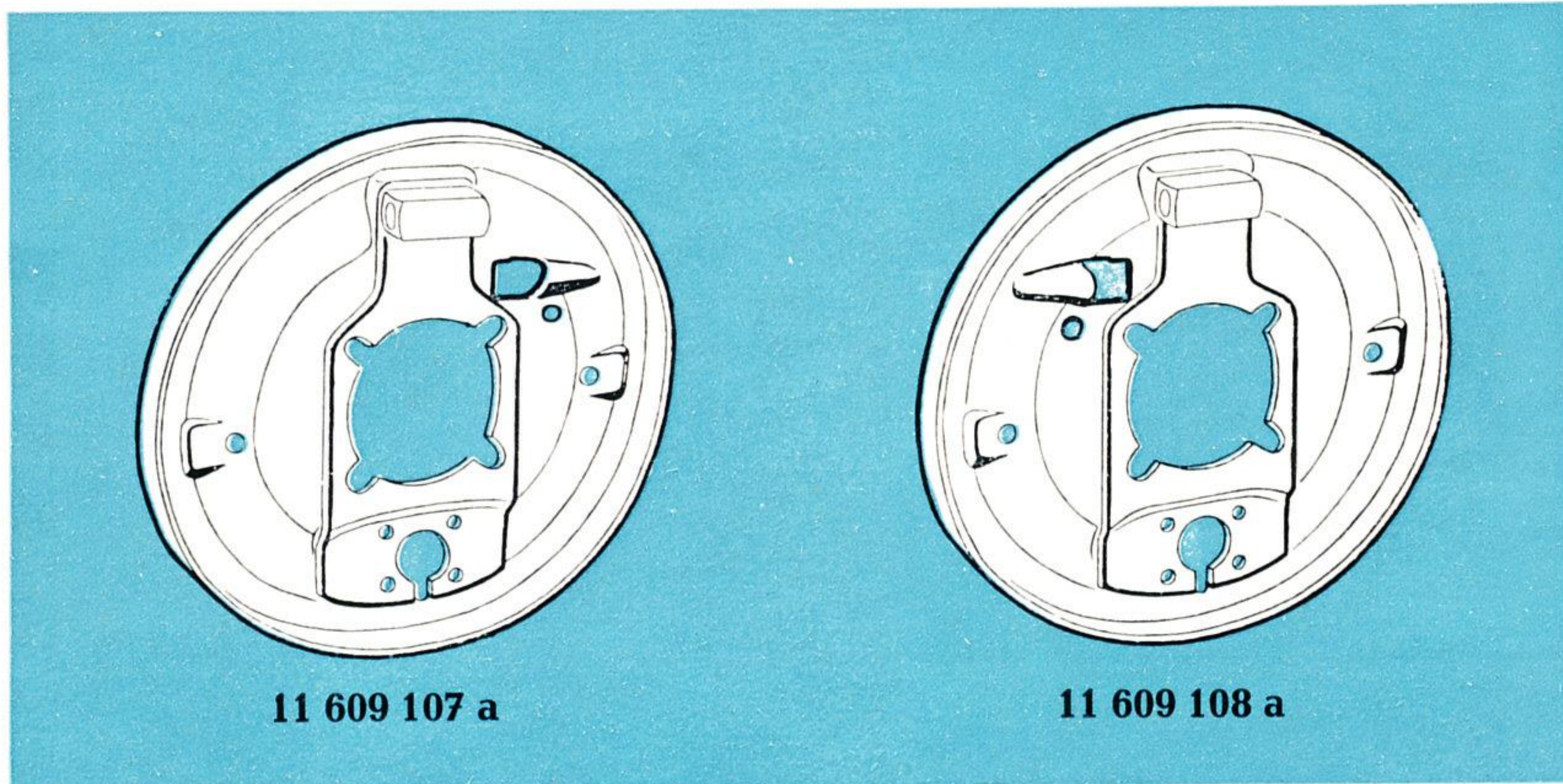

11 609 107 a

11 609 108 a

It should be noted in this connection that with the introduction of telescopic shock absorbers (from Chassis No. 0 244 003) the rear back plates had been interchanged (from one side of the axle to the other).

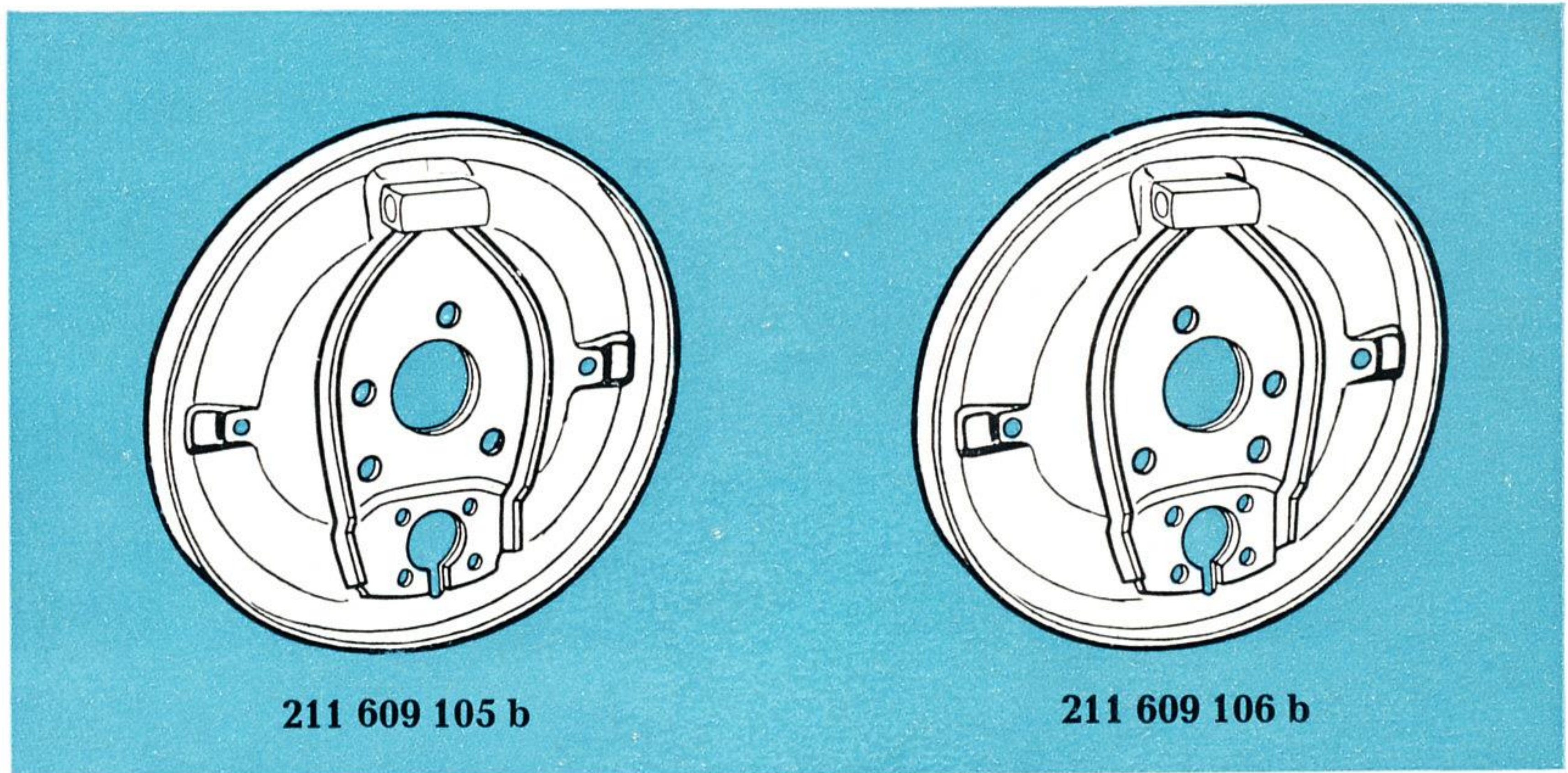

211 609 105 b

211 609 106 b

**Hydraulic Brake
Transporter (Type 2)**

Part Nos. 211 609 105 b
211 609 106 b
211 609 107 a
211 609 108 a

The four back plates shown and those of the Part Nos. 211 609 105 b/106 b/107 a/108 a have a longer anchor block (49.5 mm) than the back plates manufactured theretofore (43 mm) and are no longer provided with spring retaining brackets. The earlier type back plates will still be available until they have run out of stock. (Also see Workshop Bulletins B/4, B/5, B/6, and B/7).

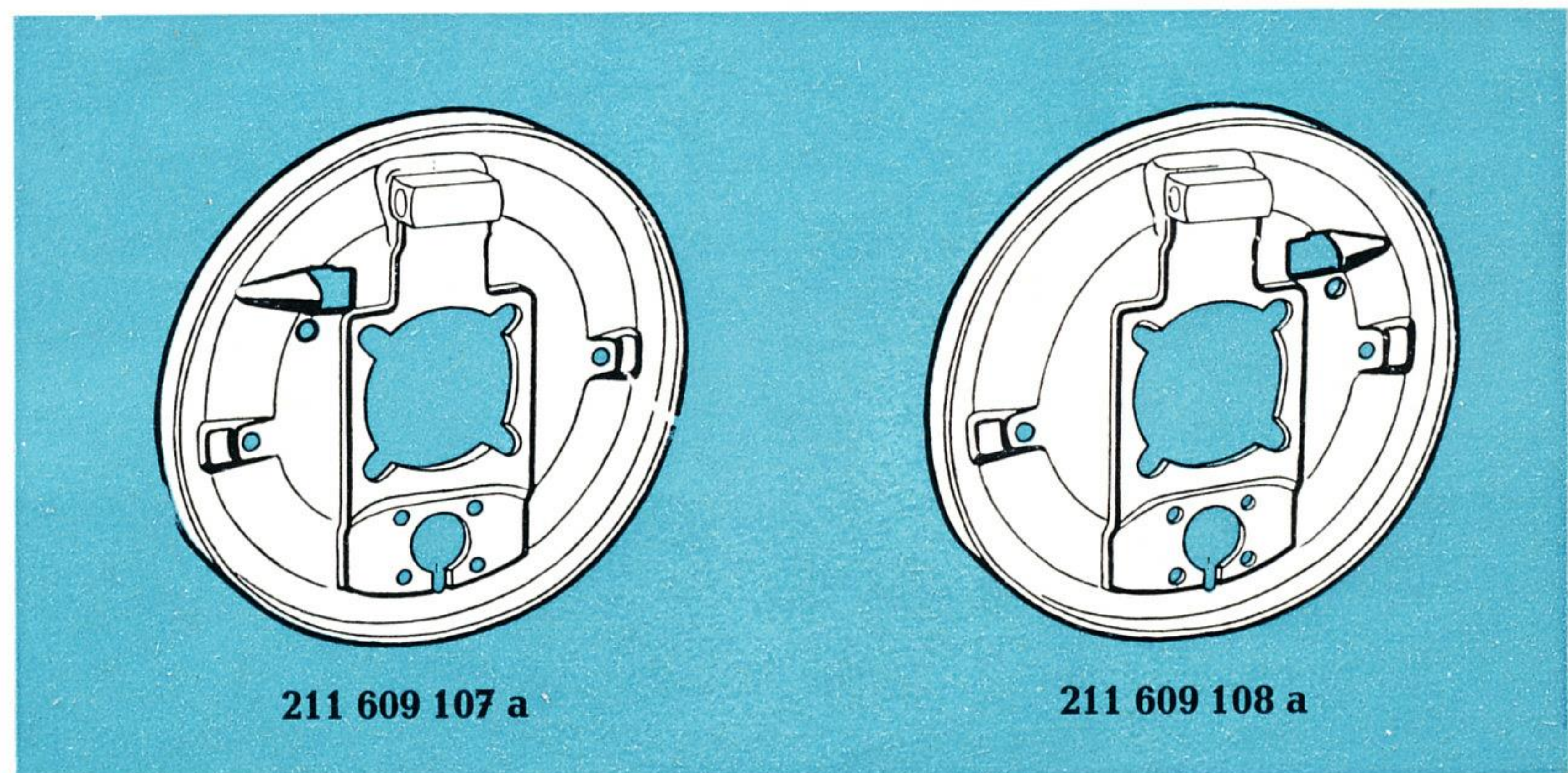

211 609 107 a

211 609 108 a

VW Gearshift Housing

301 205 a
 Gearshift housing
 types 11, 14, 15
 up to Chassis No. 1—397 022
 typ 2 up to Chassis No. 20—041 711
 Distinguishing marks:
 1 — Without bushes
 2 — Ball bearing recess 3.2 mm deep

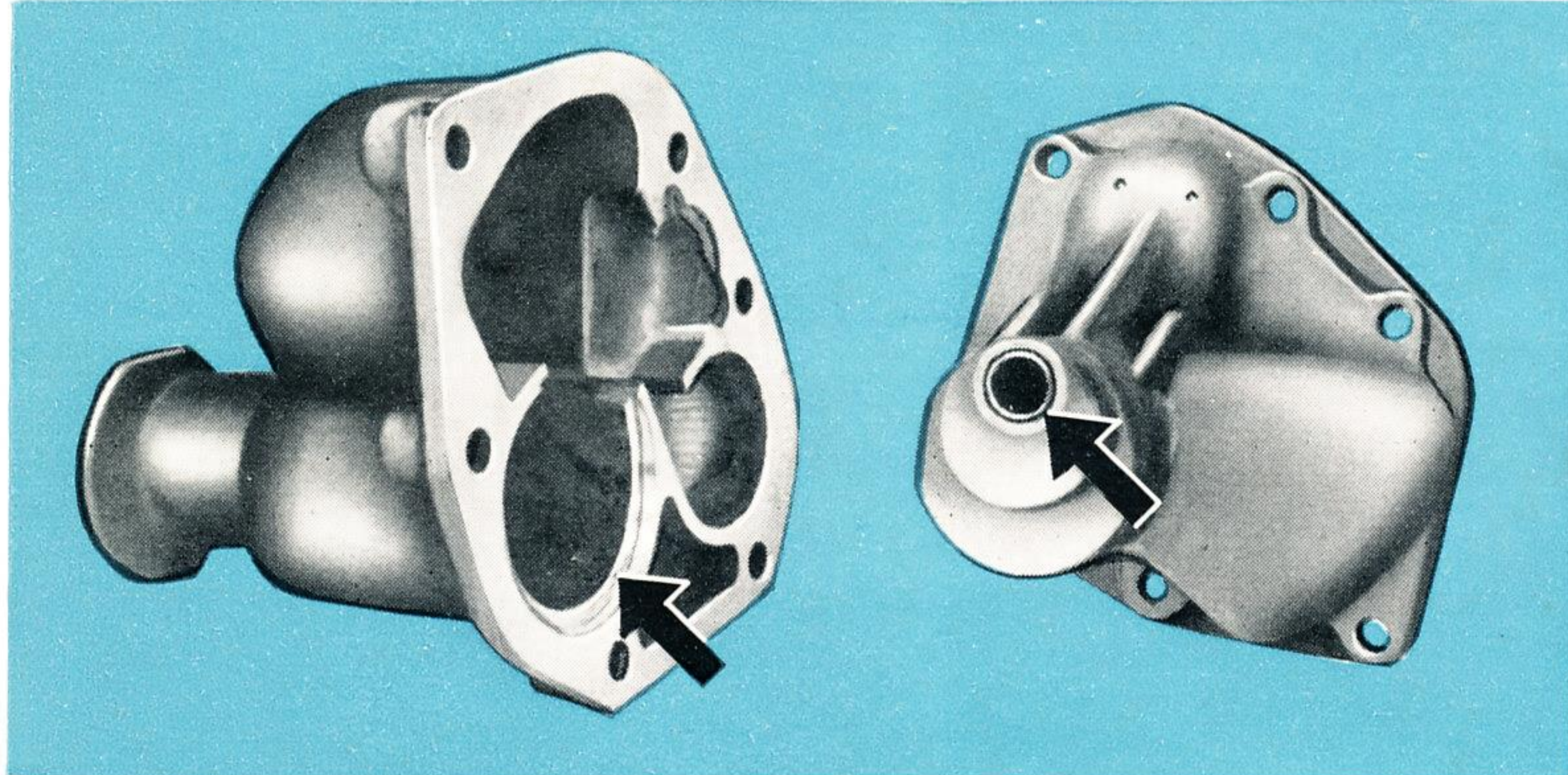
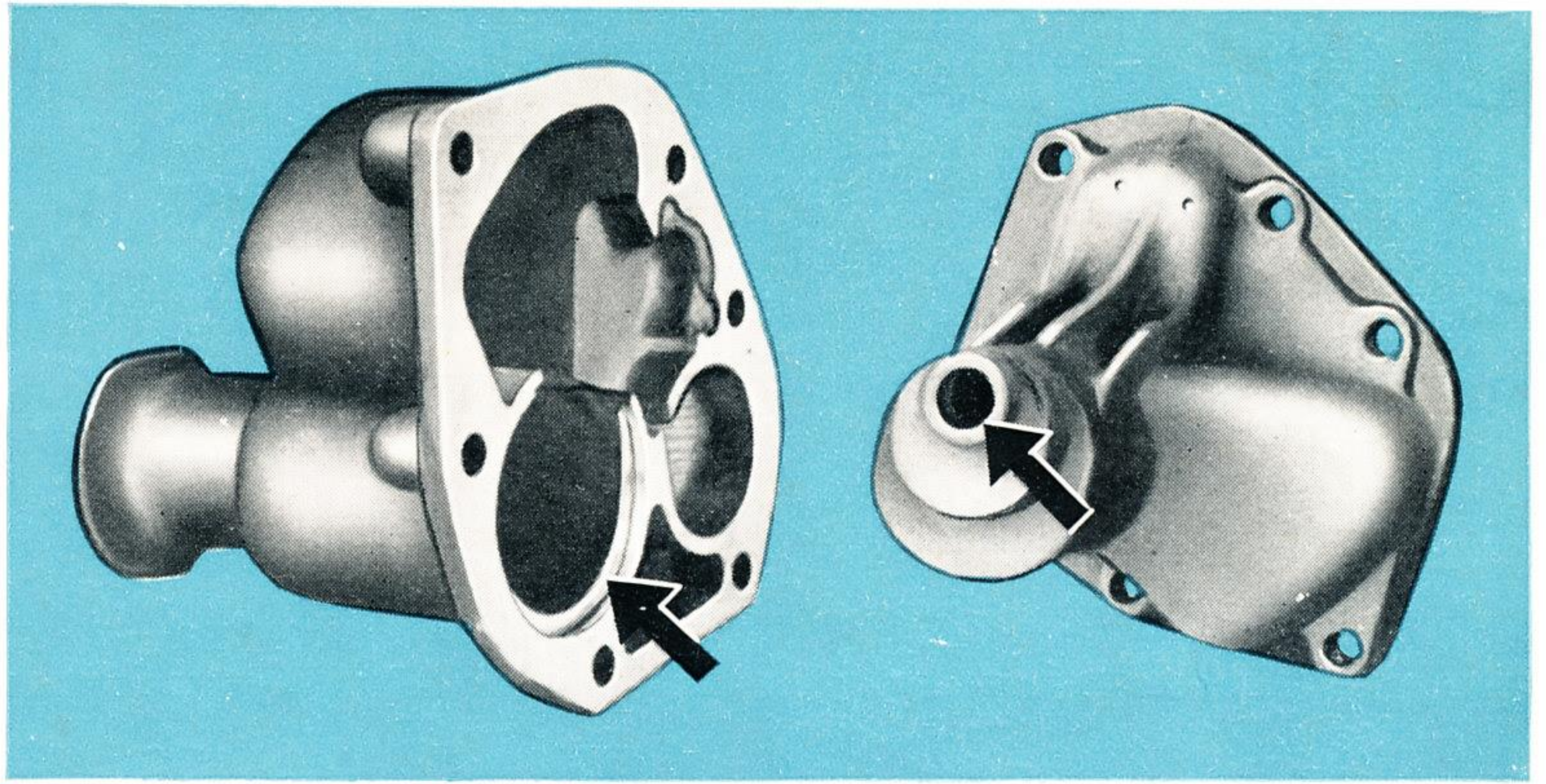

301 205 b
 Gearshift housing
 types 11, 14, 15
 up to Chassis No. 1—397 022
 typ 2 up to Chassis No. 20—041 711
 1 — With bushes
 2 — Ball bearing recess 3.2 mm deep

11 301 205
 Gearshift housing
 types 11, 14, 15
 up to Chassis No. 1—397 023
 Standard Model
 Distinguishing marks:
 1 — Ball bearing recess 3.2 mm deep
 2 — Flange for new types mounting

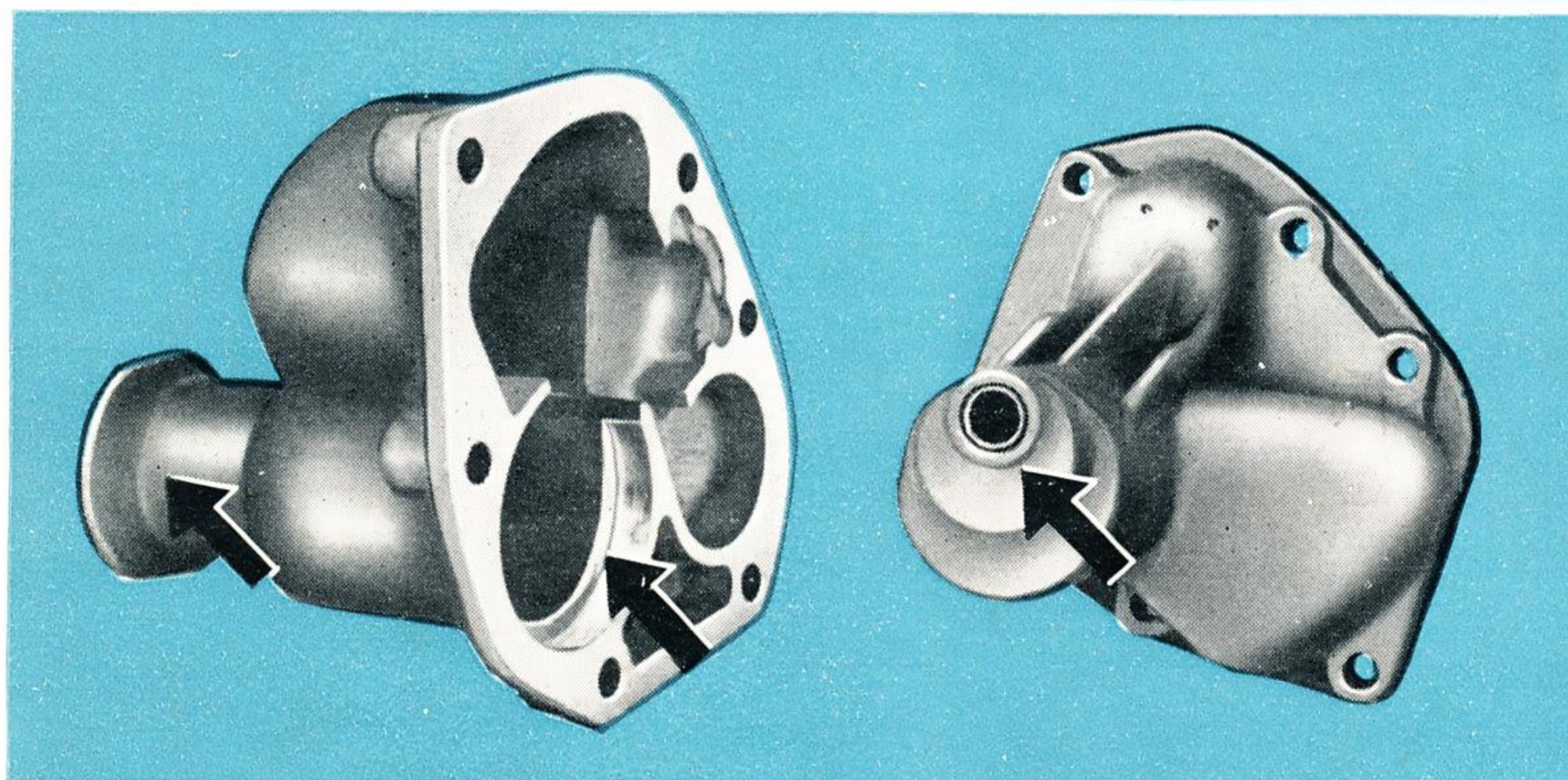
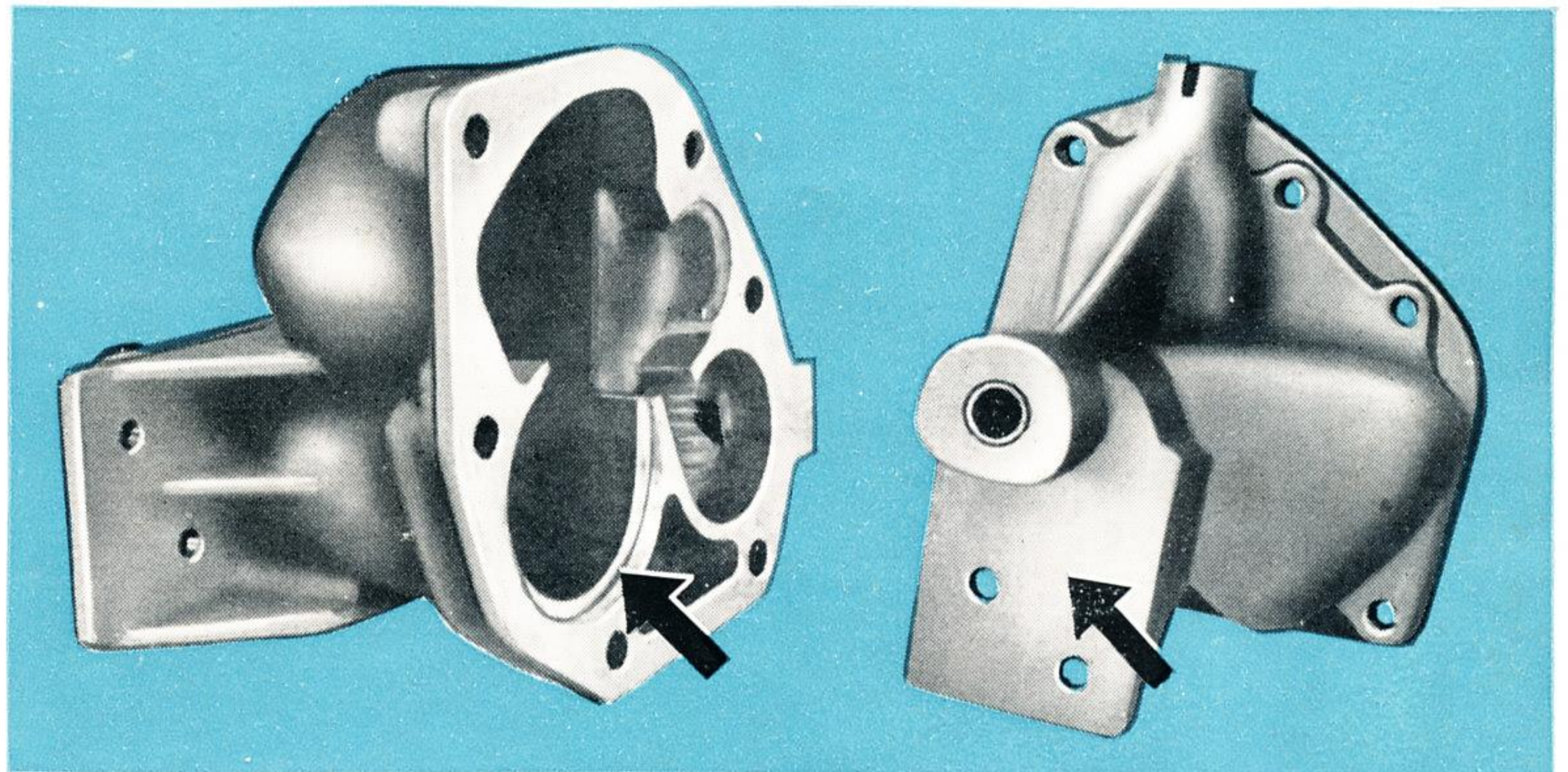

305 205
 Gearshift housing
 for subsequent installation of synchro-
 mesh transmission in car typ 1
 up to Chassis No. 1—397 022
 for typ 2
 up to Chassis No. 20—041 712
 Distinguishing marks:
 1 — Ball bearing recess 10.2 mm deep
 2 — Old type mounting

11 305 205
 Gearshift housing
 types 11, 15
 from Chassis No. 1—397 023
 De Luxe Model
 Distinguishing marks:
 1 — Ball bearing recess 10.2 mm deep
 2 — Flange for new type mounting

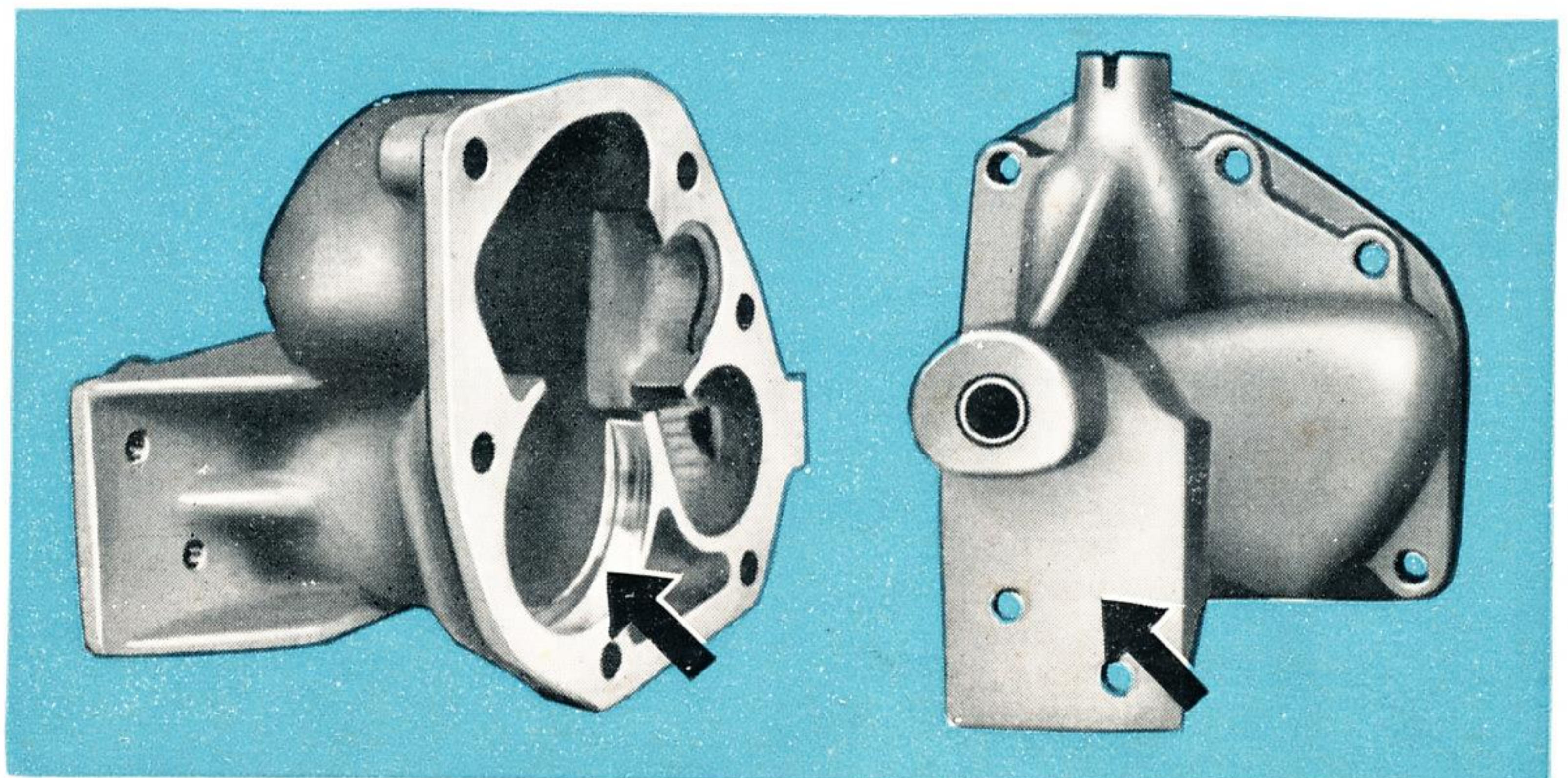

VOLKSWAGENWERK GMBH WOLFSBURG