

Typ 2 9.54 englisch

Instruction Manual



Transporter

S E P T E M B E R 1 9 5 4

INSTRUCTION MANUAL

VW-TRANSPORTER

VOLKSWAGENWERK GMBH WOLFSBURG
Germany

CONTENTS

	Page No.
Preface	5
Driver's Controls	6
Operating Instructions	9
Practical Driving	16
Winter Service	22
Lubrication	24
Wheels and Tires	30
Care of the Car	32
Maintenance	35
General Description	49
Technical Data	53
Maintenance Chart	57
Lubrication Chart	59



It is our sincere desire that the excellent performance and economical operation of your VW Transporter will justify the confidence you have placed in our firm when purchasing this new car. Diligent effort has been made to turn out an efficient and reliable car. Now, it also depends on you to assure prolonged satisfaction in the running of the vehicle. All information contained in this indispensable handbook has passed the test of experience and practice of many years and every attempt has been made to set out in full the requirements of operating the VW Transporter. In addition, this book contains interesting specification details to familiarize you with the construction and operation of the VW Transporter.

In order to promote maximum efficiency, we particularly stress the importance of following the recommendations set forth in the ensuing pages. The intimate knowledge obtained in studying this manual will prove of great value in ensuring that the utmost service and satisfaction are being obtained from your VW Transporter.

Regular attention to proper lubrication and maintenance of your car is essential. An extensive network of VW Service Stations is available, and you will readily recognize such stations by the familiar blue VW SERVICE sign. These repair shops are in closest contact with the Volkswagenwerk through our field-engineers, thus providing skillfull and expert performance of any job to be done.

Each experienced motorist knows the value of preventive maintenance. The efforts in regard to care and maintenance will be amply rewarded in the long run.

And now go ahead and enjoy your ride!

VOLKSWAGENWERK GMBH

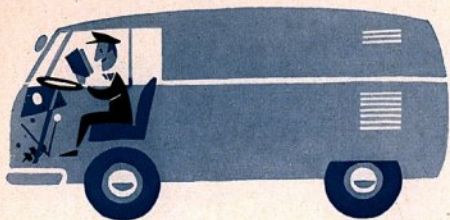

DRIVER'S CONTROLS

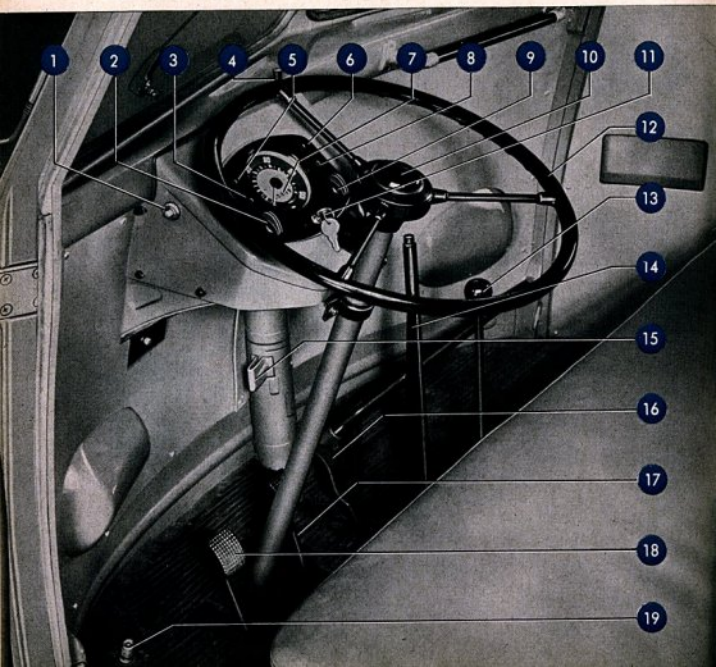

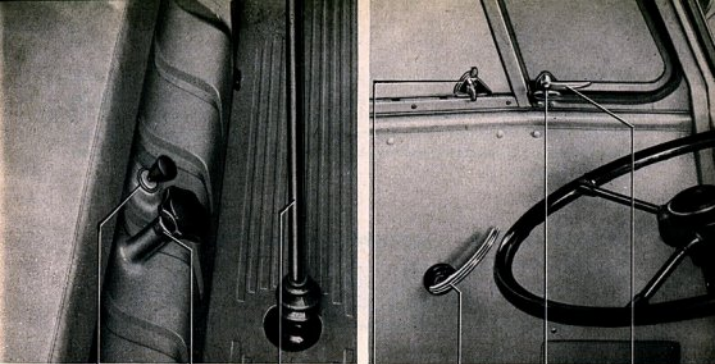

20

21

13

22

23

24

25

INSTRUMENTS:

Speedometer	7
Warning Light — Red — Generator and Cooling System	6
Warning Light — Green — Oil Pressure	8
Warning Light — Blue — Headlight Long Beam	3
Warning Light — Red — Direction Indicator	5

HAND CONTROLS:

Steering Wheel	12	Warm Air Distributor	15
Gearshift Lever	13	Switch for Windshield Wiper and Dome Lamp	2
Hand Brake Lever	14	Heater Control	21
Ignition Switch	11	Choke Control	20
Starter Button	1	Door Inner Handle	23
Direction Indicator (Trafficator) Switch	4	Vent Wing Handle	25
Headlight Switch	9	Vent Wing Release Button	24
Horn Button	10	Door Glass Retainer	22

FOOT CONTROLS:

Clutch Pedal	18	Accelerator Pedal	16
Brake Pedal	17	Headlight Dimmer Switch	19

In the documents which come with your car you will find, among other data, details regarding the model, year of construction, and chassis and engine numbers of the vehicle. The Police or Traffic Department will see to it that the information on the papers corresponds exactly with that on your car. Delay and confusion can often be avoided, if the correct information on these numbers is furnished on parts orders and correspondence.

THE CHASSIS NUMBER

is found in the right hand bottom corner of the engine compartment just above the engine front cover plate.

THE MODEL DETAIL PLATE

is found in the engine compartment on the partition panel.

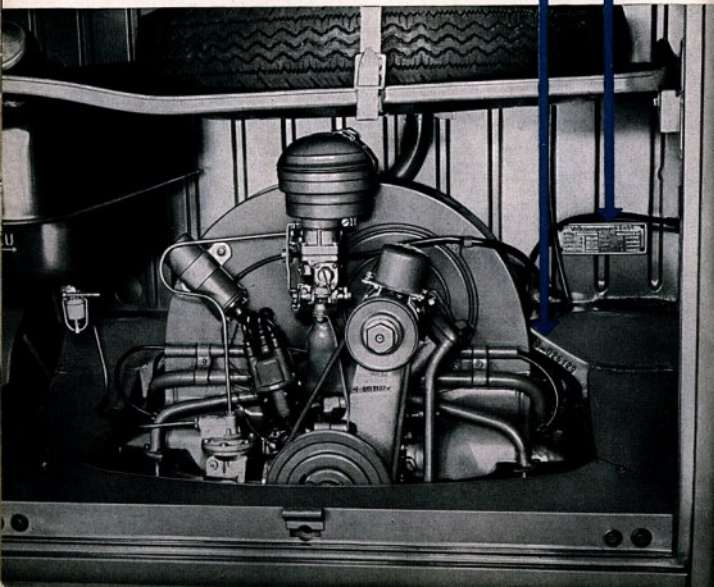



OPERATING INSTRUCTIONS

BEFORE YOU DRIVE AWAY

please check

- engine oil level
 - fan belt tension
 - quantity of fuel in the tank
 - tire pressures
 - efficiency of brakes
- and, if driving at night
- the headlights

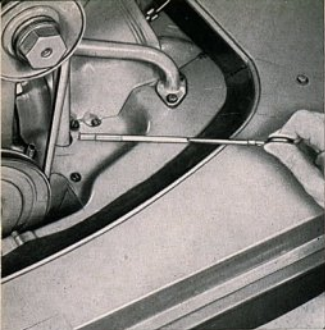

ENGINE OIL LEVEL

The oil level should be checked while the engine is not running. The oil level should be kept up to the upper mark and should never be permitted to fall below the lower mark on the dipstick.

If it should become necessary to top up the fluid level, it is recommended that a trade-mark oil be selected and constantly used. Oils of different origin behave differently when used as engine lubricants and should therefore, not be mixed.

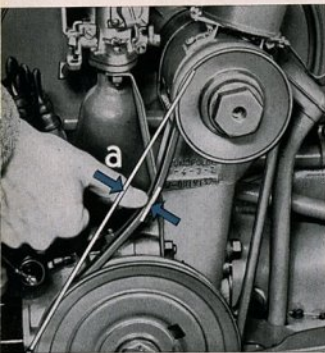

FAN BELT

The fan belt drives the cooling system of the engine. Perfect condition and correct tension of the belt insure its long life and adequate cooling of the engine. Checking is very simple: The belt, when slightly pressed with the thumb, must yield approximately 2 cm. (approx. 1 in.). No traces of excess use, such as frayed edges, should be perceptible.

$a = 2 \text{ cm. (approx. 1")}$

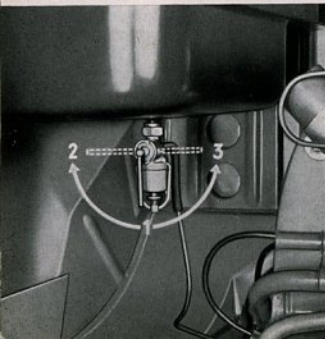

FUEL TANK

The tank has a capacity of 40 liters (10.6 U. S. gals., 8.8 Imp. gals.), sufficient for a drive of approx. 420 kilometers (260 miles). On Delivery Van, Station Wagon, and Micro Bus, the tank filler and the fuel tap are accessible from the engine compartment, whereas on the Pick-Up, the tank filler is situated on the right-hand side and protected by a cover; the square socket wrench provided is to operate the fuel tap beneath the cover.

Under normal conditions, the fuel tap should point downward, while the car is in operation. If the engine begins to "stutter", as a result of lack of fuel, just switch the tap to the left. A fuel reserve of 5 liters (1.3 U. S. gals., 1.1 Imp. gals.) will then last for a further drive of about 50 kilometers (30 miles).

It is important to re-set the tap downward when refilling the tank, otherwise there will be danger of running out of fuel on the road.

Positions of fuel tap:
1 - Open 2 - Reserve 3 - Closed



The design of the VW Engine allows an operation on all proven trade-mark fuels. The good characteristics of trade-mark fuels, including gasoline-benzol blends, are evidenced by constant physical properties, sufficient anti-knock qualities and freedom from objectionable constituents.

The selection of a type of fuel is therefore left entirely to your discretion.

THE TIRES

deserve and require your special attention. The smooth driving and the road-holding of your VW TRANSPORTER will greatly depend on their condition. Maintaining correct tire pressure and observing proper operation of the car are the most important factors in obtaining maximum tire life. Check regularly and keep tires inflated to the following pressures:

Delivery Van, Station Wagon,	
Micro Bus,	Front
Pick-Up	2.5 atm. (36 lbs. sq. in.)
	Rear
	2.75 atm. (39 lbs. sq. in.)
	Front
Ambulance	2.0 atm. (28 lbs. sq. in.)
	Rear
	2.0 atm. (28 lbs. sq. in.)

Do not forget to replace the valve dust covers after this inspection.

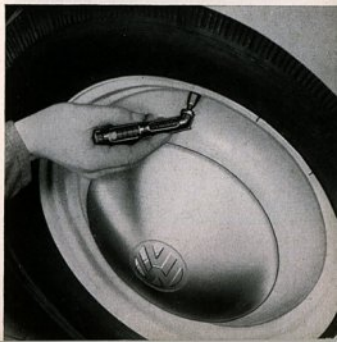

THE BRAKES

should be checked before the car starts on a trip by gradually pressing down on the brake pedal while the car is in motion to ascertain proper functioning.

GOOD HEADLIGHTS

are the first requirement of safe car operation at night. The three positions of the lighting switch are the following:

- 1 - Center position — Off.
- 2 - Switched to the left — Parking light, tail and licence plate lights.
- 3 - Switched to the right — Headlight upper or lower beam (depending on position of foot selector switch), tail and licence plate lights.

When inspecting the lighting system, do not forget the stop light, which should light up when depressing the brake pedal.

STARTING THE ENGINE

is easy, because you are now familiar with the various controls and instruments. However, make sure that the gearshift lever is in neutral position before pressing the starter button.

Insert ignition key in the switch and turn it to the right. The red generator light and the green light for the oil pressure will light up.



In cold weather, the transmission oil is apt to become thick. It is, therefore, good practice to declutch until the engine fires. Thus you will save the battery and facilitate the operation of the starting motor. You will never encounter any difficulties when starting your engine in severe frost, if you observe the rule of using adequately thin engine oil.

To start the engine **when cold**, pull out the choke control knob and press the starter button until the engine fires. Do not depress the gas pedal. As soon as the engine starts, slowly push in choke control knob (about half its travel) until the engine runs smoothly and evenly at fast idle speed without a tendency to stall.



PRACTICAL DRIVING

BREAKING-IN (RUNNING-IN) PERIOD

does not imply inconvenience as restrictions are not imposed on the speeds in the various gears.

Progressive refinements have raised the VW engine to its present predominant position and it is these refinements which allow an omission of breaking-in instructions. Your car may be operated right from the beginning at the full speeds recommended for the gears.

1 st gear	0 — 16 km. p. h. (10 m. p. h.)
2 nd gear	10 [6] — 32 km. p. h. (20 m. p. h.)
3 rd gear	20 [12] — 52 km. p. h. (32 m. p. h.)
Top gear	30 [19] — 80 km. p. h. (50 m. p. h.)

This position of the choke control knob permits a quick moving off without any detriment to the engine. Neither will harm be done to the engine when you drive for a longer period in dense city traffic with the choke pulled out half its travel. As the engine attains operating temperature, you will notice an increase in the idling speed. At the same time gradually push the choke control knob fully home.

If the engine does not start within ten seconds, just repeat the procedure a few times, allowing a short interval between each successive attempt, as the battery is being strained heavily by continuously pressing the starter button.

To start the engine **when hot**, do not pull the choke control knob. **Slowly** depress gas pedal while pressing the starter button. Do not pump the gas pedal. **It is important to know that a repeated depressing of the gas pedal makes a starting of the warm engine difficult and increases the fuel consumption.**

CAUTION!

Be careful when starting the engine inside your garage. See to it that the door and windows are open so that the exhaust fumes can escape. They contain the colorless, tasteless and odorless, yet extremely poisonous carbon monoxide gas.

DRIVING AWAY

is extremely easy, if you observe the following:

- 1 - Press down the clutch pedal as far as possible. Keep it in that position.
- 2 - Shift to the first gear. Release the hand brake.
- 3 - Engage the clutch by gently removing your foot from the pedal, while simultaneously pressing down the gas pedal. The car rolls!
- 4 - Gradually increase the pressure on the gas pedal and remove your foot completely from the clutch pedal, as the clutch is now fully engaged.

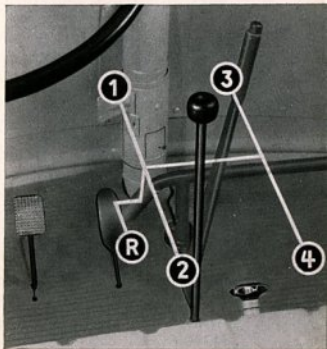

Shifting to second gear is equally simple:

- 1 - Take your foot off the gas pedal, while simultaneously pressing down the clutch pedal.**
- 2 - Shift gear lever into second position.**
- 3 - Engage the clutch by taking your foot off the pedal gently and gradually and again step on the gas.**

You now know how to "shift gears", and may at will shift to third and fourth positions. You will have noticed by now that on each shifting operation the gas and clutch pedals are operated simultaneously, but in opposite directions. It is the coordination of these simultaneous operations that brings skill in shifting gears. To engage the reverse gear, first press down the gear lever vertically, move it to the left and pull it towards the rear.

SHIFTING TO LOWER GEAR

This is what you should do in close city traffic, or with sharp turns ahead of you, or when driving up-hill.

- 1 - Release gas pedal and depress clutch pedal.**
- 2 - Shift to 3rd or 2nd gear respectively.**
- 3 - Release clutch pedal and step on gas pedal simultaneously.**

Of course, this goes much more quickly in actual operation than by describing it here. We do not want to bore you with a technical discourse, but it may be of interest to you to know that, when changing down, the synchromesh device assures meshing of the gears without clash, as the clutch of the lower speed is brought into synchronism so that both gears are turning at the same speed.

When shifting gears, it is absolutely necessary to fully depress the clutch pedal. Incomplete declutching makes gear shifting difficult and leads to rapid wear of the synchronizer stop rings.

The first gear does not require a synchronizing device, as the main drive shaft normally is not turning when the car is shifted into first. Should it become necessary to shift from second to first, the two cogwheels of the lower gear should be brought to the same ratio of speed by momentarily depressing the gas pedal with the shift lever in neutral position to insure an easy and silent engaging of the gears.

After a short period of practice, you will take pleasure in the correct handling and shifting of the gears and obtain the utmost satisfaction from the efficient performance of your new VW TRANSPORTER. Under no circumstances should you be afraid to shift to lower gear, or even try to avoid shifting occasionally by merely letting the clutch "slip" in a partly disengaged position.

Moreover, the clutch pedal should never be used as a foot-rest while driving your car!

THE LIFE OF YOUR CAR, ITS PERFORMANCE, AND ITS OPERATION WILL DEPEND ON YOUR DRIVING HABIT.

Maximum satisfaction in the running of your car will be assured by following the fundamental rules for driving an automobile:

— Do not race the engine in the gears, no matter whether the car is stationary or moving.

The new engine is not governed. Therefore, it is good practice to glance at the speedometer hand from time to time. The maximum permissible speeds in the gears are marked red on the speedometer dial.

— Do not allow the engine to labor by driving at too low speeds.

Don't believe that your engine will be saved and preserved most when it is operated at low speeds only. You won't reduce the fuel consumption either. The engine requires air for cooling, which is only attained at an adequate number of revolutions. It is overloading and overheating that are harmful to the engine, and not the number of revolutions.

— When driving up-hill

always change gear as soon as the speed drops and the speedometer hand approaches the maximum speed limit of the next lower gear. Never allow the engine to labor in 4th gear, which is nearly an overdrive, and expect it to pick up speed on feeding more gas.

ECONOMICAL DRIVING

is one of the outstanding features of your car. However, whether or not a few extra miles will be yielded from each gallon will depend on the manner in which you handle the car and shift gears.

— When accelerating,

step on the gas pedal slowly and only to such an extent as is necessary for the intended speed. Depressing the gas pedal rapidly does not improve acceleration, but results in an increased fuel consumption.

— Do not "pump" the gas pedal

unless circumstances require it. Even the small quantity of fuel additionally discharged by the accelerator pump each time the gas pedal is depressed results in a marked increase in the total fuel consumption.

BRAKES

The brakes should be applied sparingly. The inexperienced driver can be recognized by the too frequent lighting-up of the stop light. By removing your foot from the gas pedal, the engine compression will serve as a brake, thus saving fuel and preventing premature wearing of tires and brakes. Don't drive too fast and then skid to a stop, but drive at a moderate speed, commensurate with the traffic, and your car will perform most economically. To press down the brakes suddenly can only be justified when danger is ahead.

Operate your brakes especially gently when the road is wet or covered with ice. Sudden braking of the wheels will result in skidding of the car.

Here is one of the fundamental rules:

USE YOUR BRAKES BEFORE, NOT WHILE MAKING A TURN!

When driving down-hill, make use of the braking capacity of the engine compression by shifting to that gear which you would use in driving up-hill. You will save and preserve the brakes if you use them only to control the speed occasionally, and at the same time you will attain a higher degree of safety. The ignition must not be switched off.

STOPPING THE CAR

Take your foot off the gas pedal and operate the brakes gently. Shortly before the car comes to a full stop, release the clutch and place the gearshift lever in neutral position. The engine continues to idle.

If you wish to turn off the engine, merely switch the ignition key to the left.

— Operate your car smoothly and flexibly

both at city driving and on normal trips. Adapt the speed of the car to prevailing road and traffic conditions. A good driver accelerates the car moderately, slows down in time, and utilizes the braking power of the engine. Make use of the full acceleration capacity and the excellent brakes of your car only when circumstances require it.

HOW TO DRIVE AT HIGH SPEED WITHOUT SACRIFICING FUEL ECONOMY

When you have accelerated the car to the intended speed, slowly let the gas pedal return to the position which just maintains this speed. This practice is especially economical when driving on highways. If you attach particular importance not only to the economy of your car, but also to a fair average speed, it would prove of value to ascertain the most suitable range of speed. The most economical speed is between 45 and 65 km. p. h. (28 and 40 m. p. h.). The fuel consumption does not go up equally with the speed; it increases more rapidly at higher speeds. Perhaps you are aware of the fact that air resistance is an obstacle for all high-speed vehicles. Due to the simple and sweeping lines of your VW TRANSPORTER, the air resistance is relatively low, but it should be remembered that high road speed always involves a greater fuel consumption.

WATCH THE ROAD

closely while driving. As to the various manipulations of levers, switches and controls, you by now are able to operate them automatically. Furthermore, your TRANSPORTER on its own accord will "tell" you when it needs attention.

GENERATOR AND COOLING

Red Light

are controlled simultaneously by a red light. The light will go on when the ignition is switched on and when the engine is idling shortly. The light will go out when you step on the gas.

CAUTION! If the lamp lights up while you are driving the car, the fan belt may be broken. Bring your car to a stop and find out what is wrong, for when the belt is broken, the cooling is disrupted and the generator no longer charges.

OIL PRESSURE

Green Light

The oil pressure of your car is as important as the oil level, which you have already checked. When the ignition is switched on, the Green Oil Pressure Lamp will light up. The light will go out when the engine is started and the oil pressure increases.

CAUTION! If the lamp lights up during the ride, the chances are that the oil circulation has been interrupted, which means that the lubrication of the engine has ceased. Stop at once and check the level of the oil before you consult a Service Station. An occasional lighting up of the lamp with the engine warm and at low speed does not indicate trouble, if it goes out again as the speed increases.

DIRECTION INDICATORS

Red Light

The direction indicators lie outside the driver's view. However, the red indicator lamp will serve as a reminder in case you have forgotten to turn the signals off.

HEADLIGHTS

Blue Light

The country (upper) beam of your headlights throws glare into the eyes of oncoming drivers. You know yourself how unpleasant and dangerous this is. For this reason, be considerate! The blue light will tell you when the upper beam is switched on. The traffic (lower) beam is obtained by pressing the foot switch.

SPEED

The speed of your VW TRANSPORTER is liable to be underrated due to its perfect driving comfort. Special attention should be paid, therefore, to the speedometer during the initial driving period.

SAFETY FIRST

Safety for yourself, and safety for others, this is what counts most! Your VW TRANSPORTER is a car that "hugs" the road in an excellent way, and does not sway when taking a turn. Your car has an extraordinary capacity for acceleration.

Yet, the feeling of security and safety which you will acquire after a few miles should not tempt you to become careless. Therefore, adjust the speed of your car to the conditions of road, traffic and weather, and always be ready to bring your car to a stop when it is necessary. Be particularly careful when driving on wet or icy roads, for even a VW TRANSPORTER is apt to skid when not driven carefully under such conditions.

PASSING OTHER CARS

Pass other vehicles with consideration. Always be sure that the road is clear ahead of you, and look out for cars approaching you from the opposite direction. A brief look in your rear view mirror will tell you whether another car is about to pass you from behind. And here is another warning: Never try to pass a car when approaching a curve, where vision is not clear, and never pass a vehicle at the crest of a hill, or at crossroads! You never can tell what lies ahead of you! Be fair and do not step on the gas when another car tries to pass you. You will endanger your life and others!

STOPPING YOUR CAR TEMPORARILY

When stopping your car in front of a traffic light or railroad crossing, do not wait for free passage with the clutch pedal pressed down and the gearshift lever in position. Shift to first gear shortly before moving on again, it will preserve the clutch!

PARKING YOUR CAR

in a space between two other cars that are parked at the curb will be fun for you if you heed the following advice:

Stop your car even with the car in front of the space. Turn the steering wheel sharply to the right and back your car slowly into the gap.



When the front bumper of your car is even with the rear bumper of the car ahead of you, turn the steering wheel fully to the left, and back up further toward the curb.



Now turn the steering wheel again to the right and pull up a little bit, until both ends of the car come as close to the curb as possible.



When parking on a steep grade, set the handbrake so as to keep the car from rolling. As a precautionary measure, it is advisable to engage first or reverse gear in addition to the handbrake. And do not forget to take the key out of the ignition lock before you leave your car!

Prior to locking the left-hand door secure the right door by raising the inside door handle.

Do not forget to shut the fuel tap and to lock the door windows when leaving the car stationary for a longer period.



WINTER SERVICE

IN WINTER

There are two advantageous features of your VW TRANSPORTER that you will appreciate most:

AIR COOLING AND HEATING.

You may expose your car to bitter cold without fear: — its air-cooled engine will always be ready to start! You will drive in warm comfort, well protected from drafts and from sleet and snow, while a current of warm air will keep your windshield free from condensation and frost, permitting you a clear view.

The increased stress that your car has to stand in winter because of frost and dampness can be easily dealt with if you observe the following:

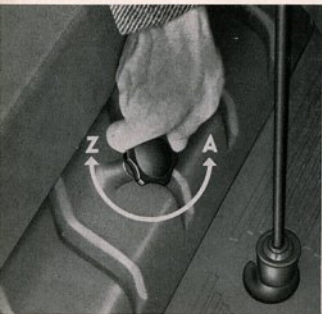

THE WARM AIR HEATING

can be regulated by a rotary knob situated under the seat:

Anti-clockwise — On (A)
Clockwise — Off (Z)

The warm air distributor in front of the hand brake lever provides an additional control.

ENGINE OIL

of the specification SAE 20 will remain thin in cold weather and will permit easy starting of the engine. At lasting frost under 15° C (5° F) the use of engine oil SAE 10 W is recommended. In cold weather, allow the engine to idle for half a minute before driving to insure correct circulation. Don't race the engine in winter to obtain a quick start.

Should you use your car mainly in city traffic and over short distances, it is advisable to have the oil changed at shorter intervals, say after every 1000 km. (600 miles).

TRANSMISSION OIL

serves its purpose in any season and requires, for this reason, no particular attention or change.

THE CHASSIS

is particularly exposed to the cold and wet weather in winter. For this reason it will be necessary, and only logical, to adhere strictly to our instructions for lubrication. If, in addition, you will spray the bottom of the car with a special chassis oil, as a protection against rusting, you will have prolonged the life of your car.

THE BRAKES

of all automobiles are exposed more or less to splashing water that in winter is apt to freeze in the brake drums. Therefore, when parking your car, do not set the hand brake, but shift to the first or to the reverse gear instead — for safety's sake!

At the beginning of the cold season, the conduit lubes of the brake cables should be thoroughly lubricated with anti-freeze lubrication grease. Do not use just any car-lubricant, but get the right one at any VW Service Station.

THE BATTERY

has to meet higher requirements in winter than in warmer seasons due to the increased consumption of current when starting the engine and using the lights at night. Besides this it is a characteristic feature of any battery that its efficiency decreases at lower temperature.

Therefore, have your battery checked regularly, and you will never press the starter button in vain!

NON-SKID CHAINS

You will need non-skid chains only when the roads are covered with snow. Without such chains, the rear wheels of your car are apt to spin, and applying the brakes may result in the car skidding. Have the non-skid chains adjusted to the wheels, if you wish to avoid loss of time and inconveniences later on! When driving on long stretches that are free from snow, the chains should be removed to prevent excessive wear of both chains and tires.

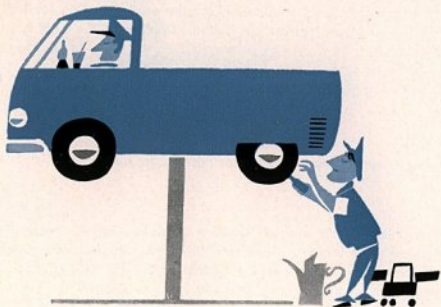

LUBRICATION

PROPER LUBRICATION IS OF VITAL IMPORTANCE TO YOUR VW TRANSPORTER

The extra time spent in following these recommendations will be amply rewarded in the long run by your car's efficient performance. It is up to you to maintain the standard of safety offered by your VW TRANSPORTER, and to insure the long life and good service which you have the right to expect from this highly economical car!

TO LUBRICATE CORRECTLY MEANS TO LUBRICATE AMPLY AND AT PRESCRIBED INTERVALS!

Therefore, do not shy at the work connected with the regular lubrication service. A Lubrication Chart can be found on page 59, indicating the respective mileages at which to lubricate.

Oil Strainer
with cover

Oil Drain Plug
for crankcase

Oil Drain Plugs
for rear axle and
transmission

Oil Drain Plug
for reduction gears
at rear wheels

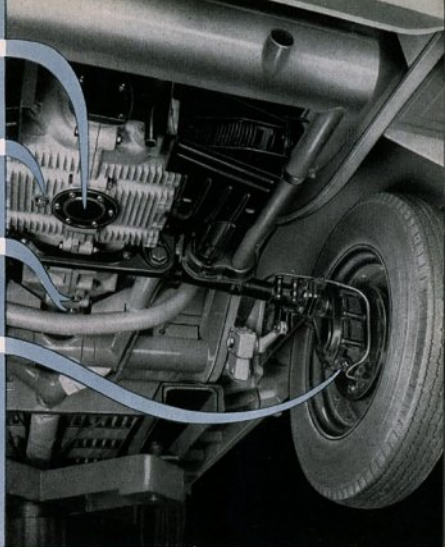

ENGINE

The change of oil at prescribed intervals is necessary even if the very best trademark oils are used. Diluted and dirty oil in your engine simply means a greater strain and a shorter period of life for your engine.

The old oil should be drained after the drain plug at the bottom of the crankcase has been removed. Draining should take place while the oil is warm. For a better cleaning of the complete lubrication system, the engine should be allowed to idle while being flushed thoroughly with 1 Liter (1 quart) of oil of the same specification as being used for filling the engine.

Under no circumstances a so-called flushing oil, or even kerosene, should be used for flushing the engine.

The residue of the flushing agent which would remain in the crankcase would decrease the lubricating efficiency of the fresh oil.

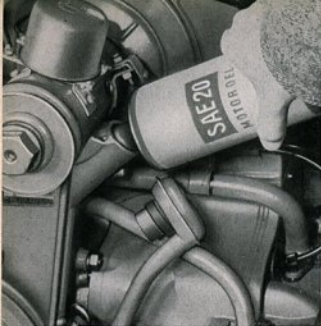

After the engine has been flushed and emptied, it should be refilled with

2½ liters (5.3 U. S. pints, 4.4 Imp. pints) of engine oil.

The oil strainer retains foreign matter and should be taken out and cleaned according to the Lubrication Chart. When the strainer is inserted again, the lower part should lie beneath the oil inlet pipe. The two gaskets should be renewed.

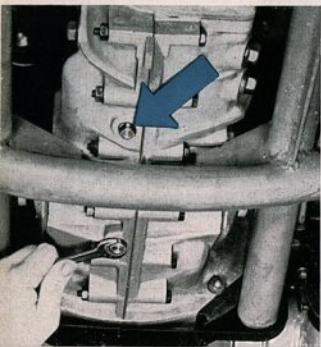

TRANSMISSION

The transmission gears and the rear wheel drive of your VW TRANSPORTER are combined in the transmission case and are lubricated jointly with gear oil. This kind of oil can be readily distinguished from regular motor oil by its heavier viscosity and darker coloring. An early change of oil, while the car is being broken in, will contribute to a smoother operation of the gears. The used oil should be drained by simultaneously removing the two drain plugs, and such draining too should be done while the oil is still warm.

Then refill with

2 liters transmission oil (4.2 U. S. pints, 3.5 Imp. pints)

The oil level should be checked in accordance with the Lubrication Chart. Keep the lubricant level somewhat below the edge of the filler hole.

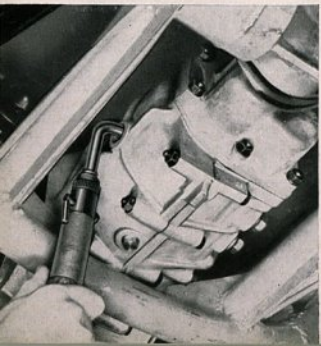

REAR WHEEL REDUCTION GEAR

Each rear wheel reduction gear case should be refilled with

**0.25 liter transmission oil
(0.5 U. S. pints, 0.4 Imp. pints)**

at the same intervals as the transmission case. Check oil level and change oil as called for in the lubrication chart.

In order to retain the special properties of the transmission oil, it is essential not to mix transmission oils of different brands.

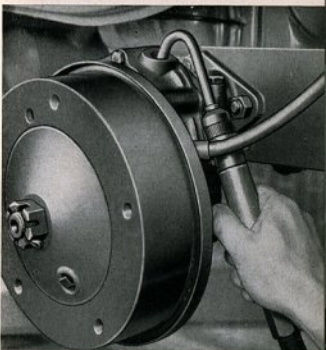

STEERING GEAR

The steering assembly should be lubricated with transmission oil exclusively, and under no circumstances with grease or hypoid oil. It is accessible through a hand-opening situated at the steering column in the bottom plate. The level of the oil in the steering case should be kept somewhat below the filler plug hole.



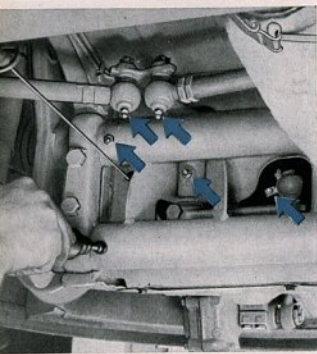
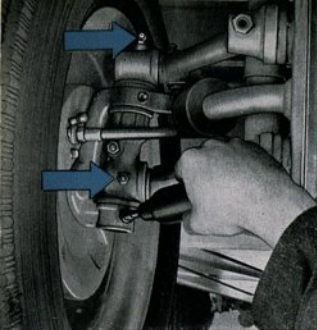

CHASSIS

A thorough lubrication of the front axle bearing points is only ensured with the front axle raised off its wheels.

Prior to lubrication, the grease nipples should be cleaned thoroughly with a clean piece of cloth, so as to avoid any dirt or foreign matter entering the nipples. The tip of the grease gun should be pressed onto the nipple, whereupon grease should be injected until the excess grease begins to emerge at the edges of the lubrication point.

Important. — The king pins and the outer tie rod ends should be lubricated **every 1000 km. (600 miles)**. The ten lubrication points are easily accessible so that you can perform this job yourself.

THE FRONT WHEEL BEARINGS

are sufficiently provided with grease already at the factory. The caps on the front wheel hubs must be free from grease.

According to the Lubrication Chart, the front wheel bearings are to be cleaned once a year at the beginning of the cold season and refilled with 125 gr. of grease for one wheel. First fill the ball bearings and accommodate the remaining grease in the brake drum hub. Finally, the front wheel bearings must be adjusted. This operation should, if possible, be carried out at a VW Service Shop.

DOORS AND LOCKS

The door latches and striker plates should be slightly greased. Apply a few drops of oil to the door and lid hinges, after dust and soil have been removed.



Door cylinder locks should be treated with graphite. Blow a small quantity of powdered graphite through the key hole. Dip the key into the graphite, insert key and move it back and forth several times.

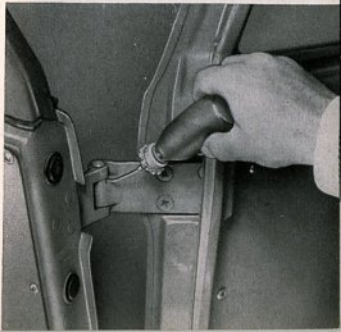



WHEELS AND TIRES

Under-inflation or over-inflation are the most common causes for tire failures. It is recommended, therefore, that the air pressure be checked frequently, preferably when the tires are normally cold (see page 11).

There are some other causes for premature tire wear which are purely the result of operating conditions and can be controlled by the driver. High speed driving and cornering, skidding to a stop and striking curbs or objects in the road may wear tires more than many miles of careful operation.

The life is affected too by incorrect front wheel alignment or lack of balance of the tire and wheel assemblies.

Avoid overloading the car and protect the tires from intense sunlight, fuel, or oil. Normal wear may be kept at a minimum by interchanging wheels and tires inclusive spare wheel at approximately 4000 km. (2500 miles) intervals. Rotate wheels as indicated below:

On the Pick-Up and the Ambulance, the spare wheel is accommodated behind the back of the driver's seat.

As a precautionary measure, you should employ the better tires on the front axle, if already unevenly worn. To obtain a smooth high speed operation and a long tire life, it is important to have the wheels balanced statically and dynamically when tubes and tires have been repaired.

When the tires are being mounted, the red mark on the sidewall should be aligned with the valve to insure better balancing of tube and tire.

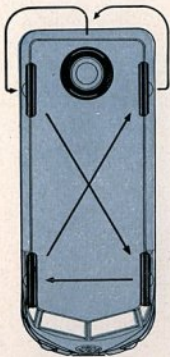

CHANGING WHEELS

To change a wheel on the road and in the rain certainly is not a pleasant task. However, it will no longer be so difficult for you after you have read these few lines which will teach you how to go about it properly. Underneath the front hood, you will find the jack and tool kit required for changing tires.

- 1 - Set the handbrake securely and block the wheel opposite to the one being removed to prevent the car shifting off the jack.
- 2 - Insert jack into the square tube below the body.
- 3 - Remove hub cap.
- 4 - Loosen wheel bolts by means of the socket wrench before wheel is fully jacked up.
- 5 - Raise jack until tire clears ground.
- 6 - Remove wheel bolts and remove wheel.
- 7 - When reinstalling the wheel, operate the jack until the five holes in the wheel are nearly lined up with the holes in the brake drum.
- 8 - First, insert one wheel bolt only. Tighten it to such a degree as to allow the wheel to be swung around this point by hand, until the remaining holes in the wheel and brake drum coincide.
- 9 - Insert the remaining bolts until the countersunk heads rest centrally in the corresponding recesses of the disc-wheel.
- 10 - Tighten all bolts diametrically opposite in turn.
- 11 - Lower the car sufficiently to contact the tire with the ground and make sure that all bolts are tight.
- 12 - Install hub cap and make sure that it is tightly seating.





CARE OF THE CAR

CLEAN AND NEAT APPEARANCE

To keep the VW TRANSPORTER looking smart and new should be a matter of pride to the driver or owner of the car. You will realize the importance of the paint finish if you consider that it is exposed to the elements; it has to resist dazzling sunshine, rain, dust, and dirt. That is why a periodic care of the body is necessary to retard any disintegrating process.

WASHING YOUR CAR

Wash your new car frequently during the first weeks. This practice will be of great advantage to the finish. For washing your car you require a soft sponge for the body, a soft brush for the wheels, a sturdy, long-handled brush for the chassis, and plenty of clear water! For drying the car you need a chamois.

The chassis and lower part of the body should first be flushed with water, to soak off the dirt, and afterward a brush should be used.

Apply an even spray of water on the exterior finish of body and wheels until dirt is soaked off. Do not allow a hard shot of water to hit the varnished surface. Using plenty of clear water, dirt should be removed with a sponge. Care should be taken to clean the sponge at short intervals so as to avoid scratches on polished parts. There are some approved shampoos which greatly facilitate this job. Avoid the use of any product which has not been recommended by your service station. It is of utmost importance to wash the body thoroughly with water after the shampoo has been applied to insure that no traces of it remain on the body.

After washing, rub down with a clean chamois to prevent water spots. Some cleaners even render the rubbing down unnecessary and it is sufficient to remove traces of water.

PRESERVATION

means to restore certain greasy substances which have been removed from the finish after a longer time by weather influences. As the greasy substances are vitally important to the elasticity of the finish, it is necessary to apply a protective water-repellent coat of wax on the body. The intensive cleaning effect of the shampoo removes this protective coating so that it should be renewed accordingly. A preservative specially produced for the finish of your VW TRANSPORTER can be obtained under the designation "L 190" from your service station. The body should be subjected to a wax application after the first eight or ten weeks and then regularly at intervals of from six to eight weeks — in any case after each shampoo washing, as already mentioned. Applying the preservative is quite easy; spray it on the body or use a soft cloth, then rub it down when dry, using polishing cotton, or a soft polishing cloth, until prismatic colors can no longer be seen when standing at an angle to the car. Of course, the car must be washed and dried carefully prior to applying the preservative.

POLISHING

You should polish your car only if its appearance has been strongly affected by road dust, sunlight and rain in consequence of an insufficient care and if the application of the preservative no longer restores the original lustre. Avoid the use of abrasives or chemically harmful products, even if their first application seems to give satisfactory results. A special polish for treating our synthetic-resin finish is also obtainable from our service stations under the designation "L 170".

Never wash or polish the car in sunlight or when the metal is warm.

HOW TO REMOVE SPOTS

By a mere washing you cannot always remove splashes of tar, oil traces, "baked on" insects, etc. As a matter of principle, such foreign matter should be removed as soon as possible, for if you neglect this rule, permanent damage to the finish may be the result.

TAR SPOTS. An unpleasant sight, to be noticed particularly on light-colored cars, are tiny tar spots which show up on hot days when driving on newly tarred roads. Tar splashes have a tendency to corrode the finish within a short time and should be removed immediately when discovered. On the way, you usually have nothing at your disposal but fuel, which may be applied with a soft cloth. Kerosene or turpentine oil may also be used. After this, the treated spots should be washed with a mild, lukewarm soap-solution, and rinsed, in order to remove traces of the cleansing agent. It is, however, better to use our preservative already mentioned, which renders the treatment with soap solution unnecessary.

INSECTS are caught especially during the night, in hot weather, by the front panel, headlights, and windshield. Once baked on they can hardly be removed with water and sponge, but should be treated with lukewarm soap solution.

BLOOMING TREES but more especially lime-trees in many instances drop tiny quantities of liquid. Cars that have been parked underneath such trees become "freckled" all over. These stains, too, can be readily taken off with soap solution. A treatment of the cleaned spots with the preservative is strongly recommended.

CLEANING SUNSHINE ROOF. Careful attention should be given to the sliding roofs to retain their neat appearance and to keep them waterproof. The fabric top may be cleaned with a brush or whisk broom and thereupon washed with a mild, lukewarm soap solution or shampoo. Finally rinse with clear water. Spots in the fabric should not be removed with fuel, but with an approved cleaning fluid. A wet top must only dry in the closed position to avoid dampstains. Especially in a closed garage it is advisable to open the door windows to produce better airing conditions.

CHROMIUM-PLATED PARTS should be lightly coated with chromium wax. It is not recommended to use grease or vaseline, as these will bind dust and dirt.

CARE OF THE UPHOLSTERY. Leather substitute upholstery should be cleaned by rubbing with a cloth slightly dampened with lukewarm soapy water.

CLEANING GLASS. The windows can be cleaned by washing with warm water and wiping dry with a clean, soft linen cloth or chamois. In order to facilitate this task on the windshield, the arms of the windshield wipers may be bent forward. To clean unusually dirty glasses, use alcohol or household ammonia and lukewarm water.



MAINTENANCE

The VW Service Organisation has made available for you an extensive network of Authorised VW Service Stations, staffed with well trained and experienced men, and equipped with all the required special tools and appliances to service your car. In event the need for service arises when touring, or far away from home, look for the well known VW Service Sign. The workshop displaying this sign is your assurance of the same expert, prompt, and courteous service you are accustomed to receive at home.

In the case you can't get to an Authorised VW Service Station in time, we are giving you some information which, if needed, will help you to carry out normal maintenance work. However, repair jobs which are beyond your capacity can only be performed by your next VW Service Station. There your car will be given expert treatment by those familiar with its construction.

This will save you time, inconvenience, and money.

SERVICING THE AIR CLEANER

All air used for combustion must pass through the air cleaner. Thus the air is freed from dust and grit which might otherwise reach the engine cylinders. Regular attention should be given to the maintenance. A dirty air cleaner reduces the performance of the engine.

The **Oil Bath Air Cleaner** should be cleaned every 4000 km. (2500 miles). Detach cleaner from carburetor, unfasten the strap and disassemble the cleaner. Remove dirty oil from oil reservoir and refill with engine oil SAE 20 up to the mark



1 - Filter element 2 - Gasket 3 - Oil reservoir

(approx. 0.25 Liter / 0.5 pint). The filter element should be rinsed in fuel, kerosene, or any other degreasing solution and then dried. The oil level should be checked and topped up approx. every 2500 km. (1500 miles) in conjunction with the engine oil changes. The oil level should not be above the mark. If the car is mainly operating under desert or other extreme conditions of dust-laden atmosphere, it is up to you to prevent premature wear by more frequently servicing the air cleaner than prescribed above. The air cleaner must, however, always be cleaned, if there is no thin oil above the sludge at the bottom of the oil reservoir.

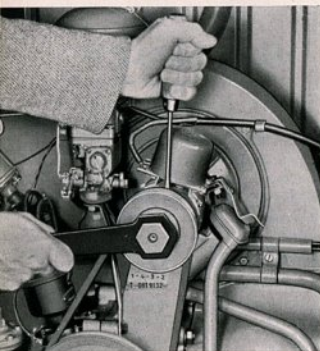

ADJUSTING THE FAN BELT

To adjust the fan belt, remove nut and outer half of generator shaft pulley. When loosening or tightening nut, insert a screw-driver in the slot cut into the inner half of the pulley, and support it against upper generator housing bolt. The adjustment of the fan belt tension is effected by means of spacer washers situated between the two pulley halves. Belt slackness is taken up by removing one or more washers. If the belt is in too much tension, one or more washers should be added.

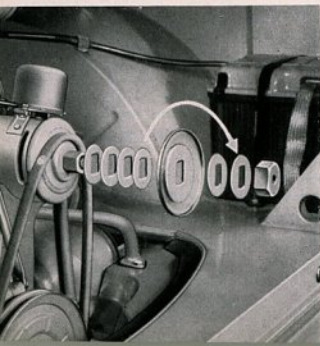

The fan belt should not be too loose, nor should it be too tight. Newly installed belts will stretch to some extent and should, therefore, be checked and adjusted after 50—100 kilometers (30—60 miles) of running.

CLEANING THE CARBURETOR

To clean the carburetor, remove the bowl cover.

BOWL COVER REMOVAL:

- 1 - Remove air cleaner.
- 2 - Disconnect the fuel line at the carburetor.
- 3 - Remove the three screws that attach the cover to the carburetor bowl.
- 4 - Lift the carburetor bowl cover.
- 5 - If it is intended to completely remove the bowl cover, disconnect the choke control cable and the throttle connector rod.

To re-assemble the unit, proceed in reverse order. Install a new gasket and be sure of its proper position between bowl and bowl cover.

CLEANING

- 1 - Remove float and lever assembly.
- 2 - Remove the main jet plug and clean main jet, and float chamber.
- 3 - Clean pilot jet air bleed.
- 4 - Clean pilot jet.
- 5 - Clean air correction jet and emulsion tube.
- 6 - Clean the float needle valve.
- 7 - Clean accelerator pump discharge passage.
- 8 - Clean passage connecting float bowl to accelerator pump.

Blow out the jets with compressed air!
Never use a pin or a piece of wire, as this will damage the jets.

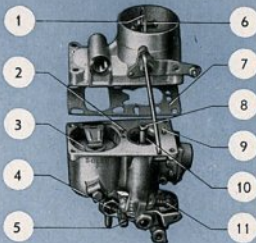
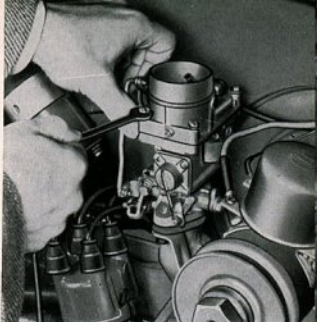

- 1 - Choke, 2 - Pilot jet air bleed, 3 - Float, 4 - Main jet, 5 - Volume control screw, 6 - Poppet valve, 7 - Gasket, 8 - Air correction jet, 9 - Filling tube, 10 - Emulsion tube, 11 - Idle adjusting screw, 12 - Accelerator pump, 13 - Throttle, 14 - Float needle valve, 15 - Pilot jet

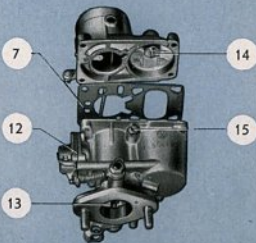

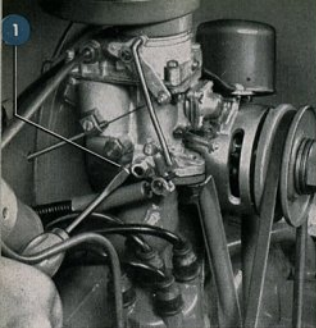

ADJUSTMENT

The carburetor is tested at the factory and properly adjusted to the engine. Do not alter this adjustment by exchanging the jets, or by changing the venturi for other than the prescribed sizes. This would be detrimental under normal operating conditions, and may result in hard starting, excessive fuel consumption or unsatisfactory engine performance.

Only an idling adjustment will be necessary from time to time, according to climatic conditions. Before attempting to adjust the carburetor, make sure the engine is at normal operating temperature.

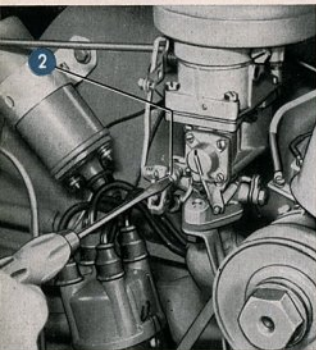

- 1 - Turn the volume control screw in until it seats lightly, then back it off approximately $\frac{3}{4}$ turn.
- 2 - Turn the idling adjusting screw in or out until the approximate idling speed is attained.
- 3 - Gradually turn in the volume control screw until the position is found where the engine just tends to stall, then back it off by $\frac{1}{4}$ turn.
- 4 - Finally re-adjust the idling adjusting screw until the engine runs at normal idling speed.

The adjustment is perfect if the engine does not stall after the throttle either is suddenly opened or suddenly shut. Poor idling may also be the result of damaged gaskets, intake manifold flanges not sufficiently tightened, faulty ignition or leaky valves.

Skilled hands and experience are required to check and adjust the carburetor. For this reason you should leave this job to an Authorised VW Station.

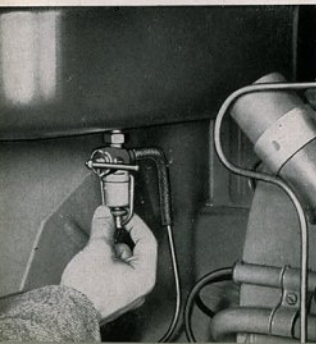

CLEANING THE FUEL FILTER

To remove the strainer, loosen the thumb nut or wing nut on the bowl base and remove the bowl. Loosen and clean the strainer. Remove dirt and water from the bowl. On reassembling the filter, make sure the gasket is in perfect condition.

VALVE ADJUSTMENT

The following procedure should be carried out only in such emergencies when it is impossible for you to reach an VW Service Station.

Valve clearance should be 0.10 mm. (.004") with the engine cold. The valve clearance increases when the engine warms up. For this reason, **only adjust valve clearance, when the engine is cold** (at room temperature).

Valve adjustment may be made in the following sequence: 1st — 2nd — 3rd — 4th cylinder. Adjust the valves when the piston of the corresponding cylinder is in top dead center position of the compression stroke.

Starting with the 1st cylinder, crank the engine over slowly to the left by the fan pulley, until both valves are in fully closed position and the timing mark on the pulley is in line with the vertical jointing faces of the crankcase.

Check the valve clearance with a feeler gauge, inserting the gauge between the adjusting screw of the rocker arm and end of the valve. If the clearance requires adjustment, loosen the lock nut of the adjusting screw and turn the adjusting screw as required to obtain the proper clearance. Tighten the lock nut and recheck the clearance. Readjust if necessary.

Check and adjust the other valves to the proper clearance in this manner by turning the crankshaft anti-clockwise another 180° for each cylinder.

CHECKING THE SPARK PLUGS

The spark plugs must be thoroughly maintained for easy starting and economical operation. Inspect their exterior before installation in the engine.

Electrodes and insulator

medium grey — good adjustment of carburetor and correct performance of spark plug.

black — mixture too rich.

lightgrey — mixture too lean.

oiled up — failure of spark plug or worn out cylinder.

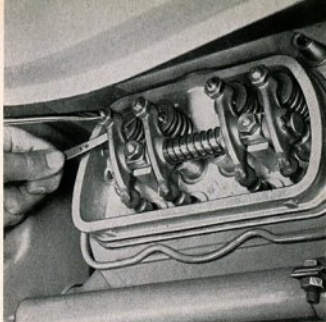

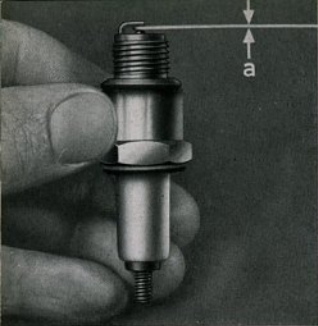

Clean the spark plugs with a brush and a chip of wood and blow them out. Inspect the spark plugs for cracked insulators and burned or pitted electrodes. The insulator should be clean and dry on the outside as well to avoid short circuits. Check the electrode gap (0.6—0.7 mm = .024—.027") and reset if necessary by bending the outer electrode. Look for a proper gasket before installing the plug. Generally speaking you may count on a service life of the spark plugs up to 15,000 km. (9300 miles).

$$a = 0.6-0.7 \text{ mm. / } .024''- .027''$$

IGNITION AND TIMING

Sufficient attention is not attached to the importance of correct ignition timing. The engine operation will be seriously affected if the ignition breaker points are not properly timed and correctly spaced. In many cases poor performance, high fuel consumption and even severe damage to the engine are the result of unskilled setting of the ignition. Normally, the adjustment should be carried out by an Authorised VW Service Station when the car is brought in for regular inspection. A few practical hints are given herewith, however, because in our experience damage is apt to result if the technical facts and data are not known.

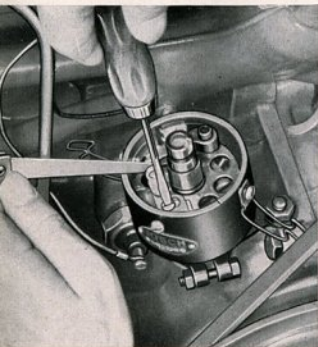

ADJUSTING CONTACT POINTS

Remove distributor cap and rotor. The breaker contact points are adjusted by cranking the engine until the fiber block on the contact arm rests on the highest point of the cam lobe. Then loosen the stationary point locking screw and turn the eccentric adjusting screw until the correct gap is obtained. Use a feeler gauge of the proper thickness (0.4 mm. = .016"). Tighten lock screw and recheck the gap.

If the points are burned, rough or pitted, replace them. Grease cam lobes slightly. The distributor cap should be clean and dry, inside and out, so as to avoid short-circuits.

AFTER THE CONTACT POINTS HAVE BEEN ADJUSTED, IT IS ABSOLUTELY NECESSARY TO CHECK THE IGNITION TIMING.

IGNITION TIMING

Crank the engine until the mark of the crankshaft pulley lines up with the vertical crankcase jointing faces and the distributor rotor arm is in the position for firing on the No. 1 cylinder (see mark on rim of distributor base). Loosen the lock screw below the distributor base and rotate the distributor body clockwise until the contact points are closed. Now switch on the ignition and rotate the distributor slowly counterclockwise until the contact points just mark to open. This may be seen and heard, for a spark will jump from one point to the other. To obtain a more accurate adjustment for maximum results, it is advisable to use a test lamp (6 volts) or an ignition timing light. The test lamp should be connected to the distributor primary lead terminal and to the ground. The lamp will light up as long as the contact points are kept open by one of the four cam lobes of the distributor shaft. After the adjustment is completed, tighten the lock screw, replace the rotor and clamp the cap on the distributor.

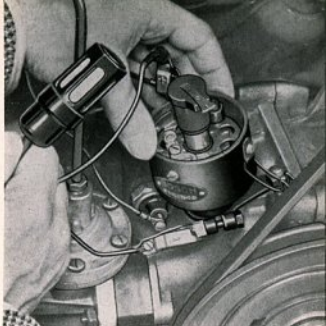

EXCHANGING FUSES

The fuse box is located below the instrument panel. When a fuse has blown out, it is not sufficient to merely replace it by a new one. Inspect the electrical system for evidence of short-circuits or other faults that may have caused the fuse to blow out. Under no circumstances should you use a fuse patched up with tin-foil or wire, because this may result in severe damage. We suggest that you carry with you a set of spare fuses (8/15 amp.).

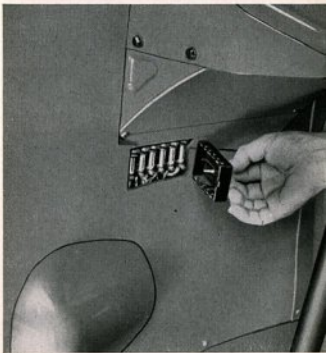

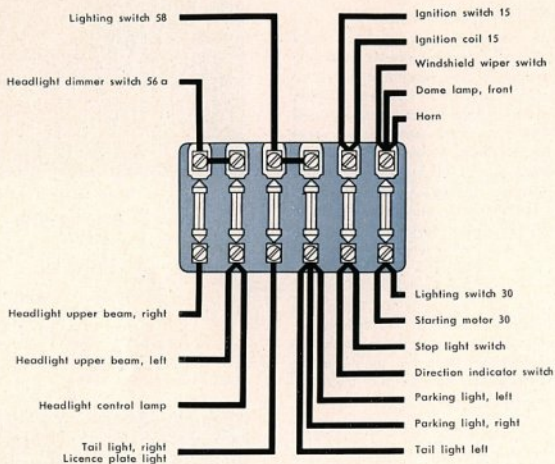

Fuse box below the instrument panel

STOP AND LICENCE LIGHT BULB REPLACEMENT

The stop light is accessible by removing the slotted screws in the glass rims.

Make sure that the bulbs properly contact the terminals.

The tail lights and the licence plate light are accessible by lifting the engine compartment lid.



CONTROL AND INSTRUMENT LIGHT BULB REPLACEMENT

The lamps for oil pressure, charging, direction indicator and headlight main beam control as well as the speedometer lamp are accessible after the lining under the instrument board has been removed. The sockets of the control lamp can be pulled out after lifting the retaining spring.

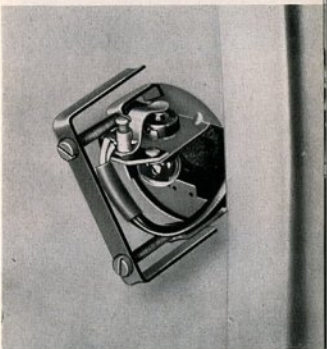

BATTERY MAINTENANCE

Ready starting of the engine depends upon perfect condition of the battery. Inspect the battery regularly as prescribed in the Maintenance Chart and even more frequently under conditions of extreme heat.

The state of charge of the battery may be checked by means of a battery hydrometer. The specific gravity of the battery liquid will increase with the charging of the battery. Tested with the hydrometer, the gravity can be read from the scale of a float.



Battery fully charged	1.285 = 32° Bé
Battery semi-charged	1.230 = 27° Bé
Battery fully discharged	1.142 = 18° Bé

In addition, a volt-ammeter test should be made to insure that the battery is in good operating condition and able to provide the necessary current. The voltage of each cell should not fall below 1.6 volts while taking the reading (10—15 seconds). Otherwise the cell is discharged or defective. Under no-load conditions each charged cell should read 2 volts.

Add distilled water to each cell to bring the level to approximately 15 mm (.59") above the plates. Losses by evaporation may only be replenished by adding distilled water. Never add acid, unless it is known that acid has been spilled from the battery. Check specific gravity afterwards and compensate if necessary.

Use a stiff brush to remove corrosion from both posts and terminals. Coat the clean posts and terminals with light grease or vaseline to prevent corrosion. Then tighten securely and make sure that there is a proper connection to the ground.



BULB REPLACEMENT

Loosen the slotted screw at the headlight rim. Pull out the lens and reflector unit, unhook the supporting spring, and remove the socket. When replacing the bulb, make sure the new bulb is clean and that it is not loose in the socket. When a broken lens is being replaced, the reflector should not be touched or wiped off.

AIMING THE HEADLIGHTS

Place the car on a level position with a dark-colored vertical screen 5 m. (16 feet) ahead. Next draw two cross lines on the screen according to the sketch. The longitudinal center line (car axis) must hit the center of the screen exactly between the two cross marks. Switch on the upper (country) beams and check the beams at the cross marks. Independent adjustment of both horizontal and vertical aim is provided with the adjustment screws accessible from the front of the headlight rim.

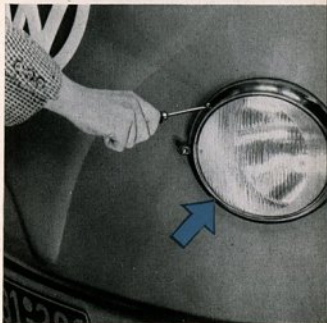

VERTICAL ADJUSTMENT

Right Headlight:

Turn lower screw to left — Beam swings up.
Turn lower screw to right — Beam swings down.

Left Headlight:

Turn upper screw to left — Beam swings down.
Turn upper screw to right — Beam swings up.

HORIZONTAL ADJUSTMENT

Right Headlight:

Turn upper screw to right — Beam swings to right.
Turn upper screw to left — Beam swings to left.

Left Headlight:

Turn lower screw to left — Beam swings to right.
Turn lower screw to right — Beam swings to left.

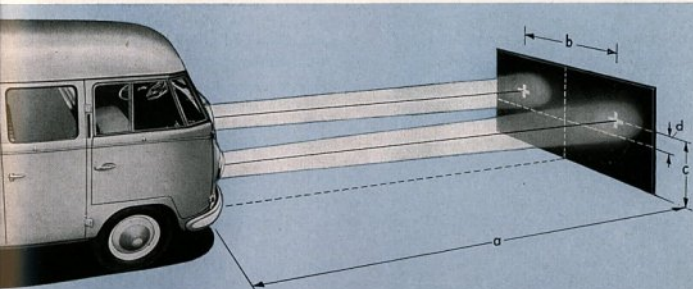

Dimensions: $a = 5 \text{ m}$ (16.4 ft.) $b = 1100 \text{ mm}$ (43.3 in.) $c = 785 \text{ mm}$ (31 in.) $d = 50 \text{ mm}$ (2 in.)
(d) is the correct distance between the upper limit of the light spot and the center of the cross when adjusting the lower (traffic) beam.



BRAKE ADJUSTMENT

Brake adjustment should be performed by an Authorized VW Service Station. However, if an emergency arises where the brakes must be adjusted before you can reach the next repair shop, the following procedure for bleeding and adjusting can be used: The master cylinder is accessible by lifting the inspection plate situated in the floor of the driver's compartment.

To fill up, use only VW-ORIGINAL BRAKE FLUID or LOCKHEED BRAKE FLUID. The fluid reservoir should be kept at least $\frac{3}{4}$ full at all times.



BLEEDING HYDRAULIC SYSTEM

The hydraulic brake system must be bled whenever a fluid line has been disconnected or air has got into the system. The presence of air will cause "spongy" brake pedal operation.

- 1 - Remove rubber cap of the bleeder valve of one wheel cylinder and attach one end of the brake bleeder hose to the valve.
- 2 - Place the opposite end of the bleeder hose in a glass container partly filled with brake fluid so that the end of the hose is submerged.
- 3 - Turn the bleeder valve to the open position (1 to 2 turns) with a 7 mm. spanner.
- 4 - Pump the brake pedal several times, until bubbles cease to appear in the container. Make sure that enough brake fluid remains in the fluid reservoir, since otherwise air will be sucked in.
- 5 - Keep the brake pedal in the fully depressed position until the bleeder valve is closed.
- 6 - Remove bleeder hose and replace bleeder valve rubber cap.
- 7 - Repeat the operations on the other wheels. Finally check and, if necessary, top up fluid level of master cylinder reservoir.

ADJUSTING HYDRAULIC BRAKE

Too much free travel of the brake pedal is an indication that the clearance between brake shoes and brake drums has become too great and that the brakes need adjustment. This adjustment will usually compensate for such wear that will take place until relining of the shoes is required.

- 1 - Jack up the car and turn forward the wheel to be adjusted, until the hole in the brake drum is in line with one of the adjusting nuts.
- 2 - Insert a screwdriver through the hole and turn the adjusting nut in the direction indicated by the arrow until a light drag is noted when wheel is turned by hand.
- 3 - Repeat procedure on the other adjusting nut. Note the opposite turning direction of the two nuts.
- 4 - Back off the adjusting nuts by 3 to 4 teeth.
- 5 - Repeat the above operations on the other wheels.

When adjusting the rear wheel brakes, the hand brake must be released.

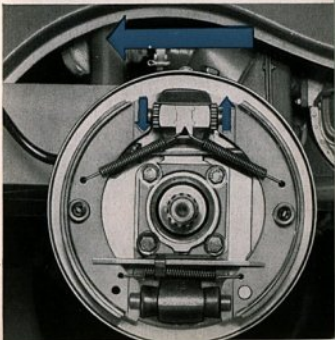
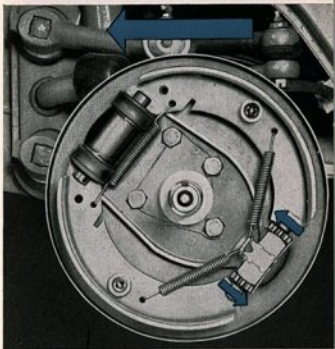

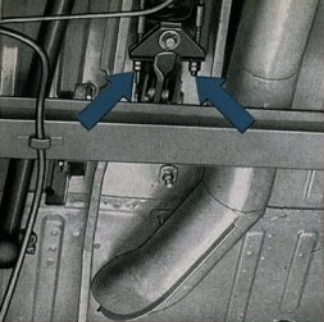

ADJUSTING HAND BRAKE

- 1 - Jack up both rear wheels.
- 2 - Tighten adjusting nuts on the front ends of the brake cables to a degree which will still allow the rear wheels to turn freely when the hand brake is released.
- 3 - Pull up hand brake lever by two notches and make sure both rear wheels have the same braking effect. At the fourth notch it should be impossible to turn the wheels by hand.

STEERING GEAR

Only a minimum of maintenance is necessary to the steering gear. The need for adjustment will be evidenced by the development of excess free play in the steering wheel. The play should be as small as possible, but care must be taken that the front wheels resume their straight-ahead position after the car has taken a turn. As special experience is needed to properly service this unit, all operations or adjustments required should only be performed by an Authorised VW Service Station.

The maintenance service provides the regular adjustment of the torsion arm link pins on the front axle. After this operation, it is absolutely necessary to check the toe-in of the front wheels.

FRONT WHEEL BEARINGS

We recommend to refer this operation to an Authorised VW Service Station, as mal-adjustment may cause severe damage to the roller bearings.

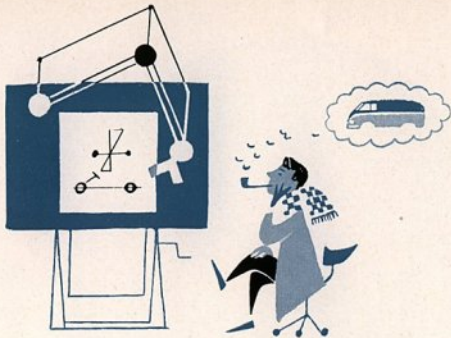

GENERAL DESCRIPTION

ENGINE

The engine, located in the rear of the car, is mounted in a floating way on the recessed flange of the rubber-cushioned gearbox. Two pairs of cylinders are horizontally opposed. Each pair has one mutual cylinderhead made of light alloy. The overhead valves are located in the cylinderhead and are operated by means of push rods and rocker arms. The short and counter-balanced crankshaft rests in four replaceable special light alloy bearings and is heat-treated at its four points of support. It drives the camshaft by means of helical gears. The connecting rods are fitted with interchangeable steel-backed lead-bronze bearings. The pistons are made of aluminium alloy.

A down-draft carburetor produces the fuel and air mixture to supply the cylinders. The engine is equipped with battery ignition.

The oil pump of the full pressure lubrication is driven by the camshaft and sucks the oil from the crankcase through a strainer, from where it will reach the points of lubrication via an oil radiator. In cold weather, when the oil is of higher viscosity, an oil pressure relief valve makes it possible for the engine to be lubricated directly, that is, by avoiding the oil cooling system.

The air cooling of the engine is done by means of a fan, which is attached to the extended generator-shaft and driven by a V-belt. The fan sucks in air through an opening in the fan-housing, and the air cools the engine by passing through the cylinder fins. A thermostat controls the cooling air and insures a proper balance of the operating and heating temperatures.

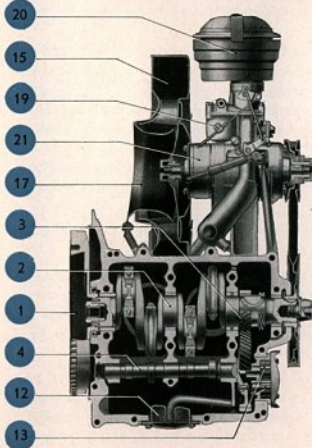
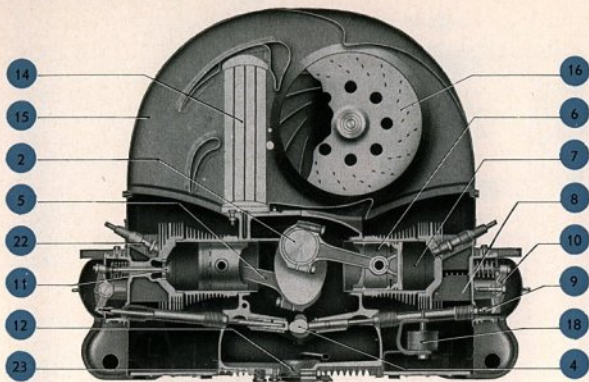

ENGINE

- 1 - Flywheel
- 2 - Crankshaft
- 3 - Crankshaft timing gear
- 4 - Camshaft
- 5 - Connecting Rod
- 6 - Piston
- 7 - Cylinder
- 8 - Cylinder head
- 9 - Valve push rod
- 10 - Rocker arm
- 11 - Valve
- 12 - Oil strainer
- 13 - Oil pump
- 14 - Oil cooler
- 15 - Fan housing
- 16 - Fan
- 17 - Throttle ring
- 18 - Thermostat
- 19 - Carburetor
- 20 - Air cleaner
- 21 - Generator
- 22 - Spark Plug
- 23 - Oil drain plug

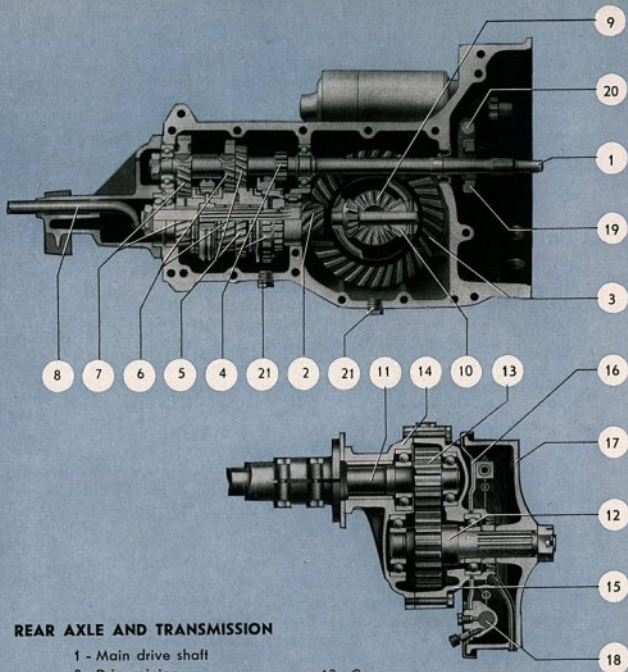

REAR AXLE AND TRANSMISSION

- | | |
|----------------------------|--------------------------------|
| 1 - Main drive shaft | 12 - Gear |
| 2 - Drive pinion | 13 - Reduction gear shaft |
| 3 - Ring gear | 14 - Reduction gear case |
| 4 - 1 st gear | 15 - Reduction gear case cover |
| 5 - 2 nd gear | 16 - Brake back plate |
| 6 - 3 rd gear | 17 - Brake drum |
| 7 - 4 th gear | 18 - Brake wheel cylinder |
| 8 - Transmission shift rod | 19 - Clutch release bearing |
| 9 - Differential side gear | 20 - Clutch operating shaft |
| 10 - Differential pinion | 21 - Drain plug |
| 11 - Rear axle shaft | |

TRANSMISSION AND FINAL DRIVE

Power from the engine is transmitted to the gears via a dry single-disc clutch. The transmission provides four speeds forward and one reverse. All models are equipped with synchromesh devices for the 2nd, 3rd, and 4th gears, which are helically cut to provide silent operation. The driving pinion and the ring gear of the rear axle are cut spirally. The two floating rear axle shafts are flexible supported in the differential housing.

Spur wheel reduction gears are provided on the outer ends of the rear axle tubes.

AXLES AND STEERING

The front axle consists of two rigidly joined tubes containing the torsion springs, the outer ends of which carry the trailing suspension arms. The front wheels are sprung independently. The suspension arms form parallelograms assuring proper steering and suspension geometry under all driving conditions. Stops with rubber buffers are provided to prevent excessive rebound.

The rear axle is of the swing half-axle type. The rear wheels are also independently sprung by means of adjustable round steel torsion bars. Double acting hydraulic shock absorbers in front and rear prevent rebound.

The foot brake, which operates on all four wheels, is of the hydraulic type. The hand brake operates on the rear wheels through cables.

The steering gear, which is of a worm and cam follower type, actuates the steering arms of the independent suspension by a draglink and a divided track rod.

BODY

The body is of a self-supporting, all-steel design, provided with a strengthening frame for supporting the axles. The position of the loading space within the wheelbase insures an even distribution of the load on all four wheels, no matter how the load is placed. The tarpaulin of the Pick-Up as well as the tarpaulin frame can easily be removed and replaced. The driver's compartment, for 2-3 persons, offers exceptional driving visibility. Adequate ventilation is insured by ventilator wings and sliding windows. Engine, fuel tank, and spare wheel are accessible by lifting the rear lid.

HEATING SYSTEM

Heated air, which is taken from the air flow warmed up by the engine, is guided through the middle of the car into the driver's compartment by one duct in the floor and two vents at the windscreen to keep it free from frost. The passenger's compartment of the Midget Bus is heated by additional vents under the rear seats. The heating system can be controlled from the driver's seat by means of a pulling knob.



TECHNICAL DATA

ENGINE

Design	4 Cylinder, 4 Cycle, O.H.V.-Type, in Rear of Car	
Arrangement of Cylinders	Horizontally Opposed (Flat Four)	
Bore	77 mm. (3.031")	
Stroke	64 mm. (2.520 In.)	
Capacity	1192 c. c.	
Compression Ratio	6.6	
Valve Clearance	Intake 0.10 mm. (.004")	} to be adjusted when engine is cold
	Exhaust 0.10 mm. (.004")	
S. A. E. Horsepower	36 HP. at 3700 R. P. M.	
Lubrication	Full Pressure (Gear Pump with Oil Cooler)	
Oil Capacity	Metric — 2.5 Liters U. S. — 5.3 Pints Imp. — 4.4 Pints	
Fuel Pump	Diaphragm Type	
Carburetor	Down-Draft Type Solex 28 PCI	
Cooling System	Air Cooling by Fan, Automatically Regulated by Thermostat	
Battery	6 Volts, 84 Ampere Hours	
Starter	Bosch EED 0.4/6 L 4 (.4 HP., 6 Volts)	
Generator	Bosch RED LJ/REF 160/6/2500 L 4 with Voltage Regulator	
Ignition Distributor	Bosch VJ 4 BR 8	
Firing Order	1—4—3—2	
Breaker Points Open	7.5° before T. D. C.	

Breaker Point Gap	0.4 mm. (.016")	
Spark Plugs	Bosch W 175 T 1	} 14 mm.
	Beru 175/14 u2	
	Lodge H 14	
	Champion L 10 S	
	AC 45 - L	
Spark Plug Gap	0.6 to 0.7 mm. (.024" to .027")	

CLUTCH

Design	Single Disc, Dry
Pedal Free-Play	10 to 20 mm. (1/2"—1")

TRANSMISSION

4 Forward Speeds, 1 Reverse 2nd, 3rd, and 4th Gears Synchronized and Silent.

Gear Ratios	First: 3.60 : 1
	Second: 1.88 : 1
	Third: 1.23 : 1
	Top: 0.82 : 1
	Reverse: 4.63 : 1

REAR AXLE

Power is transmitted through helically-cut drive pinion and ring gear, via two swinging axles and spur wheel reduction gears to the rear wheels.

Ratio	4.4 : 1
Oil Capacity of Transmission and	
Rear Axle	Metric — 2.5 Liters
	U. S. — 5.3 Pints
	Imp. — 4.4 Pints

REAR WHEEL REDUCTION GEARS

Ratio	1.4 : 1
Oil Capacity of Reduction Gear Cases	
	Metric — 0.25 Liter
	U. S. — 0.5 Pint
	Imp. — 0.4 Pint

CHASSIS

Suspension, Front	Two Square Torsion Bar Springs
Suspension, Rear	One Round Torsion Bar Spring on Each Side

Shock Absorbers	Double Acting Hydraulic Type, Front and Rear
Steering	Ross cam and lever steering gear with rolling stud contact
Turns of Steering Wheel, Lock to Lock	2.4
Turning Circle	12 Meters (39 Feet)
Foot Brake	Hydraulic Brake, Operating on all 4 Wheels (Ate)
Hand Brake	Mechanical, Operating on Rear Wheels
Wheels	3.50 D × 16, Drop-Center Type
Tires	5.50—16
Inflation Pressure	Front: 2.5 atm. (36 lbs./Sq. In.) Rear: 2.75 atm. (39 lbs./Sq. In.)
Ambulance	2.0 atm. (28 lbs./Sq. In.) front and rear
Wheel Base	2400 mm. (7 Ft. 10.5 In.)
Track	Front: 1356 mm. (4 Ft. 5.4 In.) Rear: 1360 mm. (4 Ft. 5.6 In.)
Camber of Front Wheels	0° 40'
Toe-in (Car in fully loaded condition)	2—5 mm. = .08 In.—.2 In.
Castor	0°

DIMENSIONS AND WEIGHTS

	Delivery Van Micro Bus Kombi	Micro Bus De Luxe	Pick-Up without tarpaulin	Pick-Up with tarpaulin	Ambulance
Length	4.19 m.	4.22 m.	4.19 m.	4.19 m.	4.19 m.
Width	1.70 m.	1.75 m.	1.71 m.	1.71 m.	1.70 m.
Height	1.90 m.	1.90 m.	1.89 m.	2.23 m.	2.00 m.
Ground Clearance25 m.	.25 m.	.25 m.	.25 m.	.25 m.

Delivery Van and Kombi

Loading Space

Length	2.00 m.	} approx. 4.0 cu. m.
Width	1.50 m.	
Height	1.35 m.	

Luggage Compartment

Length70 m.	} .6 cu. m.
Width	1.50 m.	
Height55 m.	

Pick-Up

Loading Area

Length	2.60 m.	} approx. 4.2 Sq. m.
Width	1.57 m.	

Height of Side Boards37 m.
Height of tarpaulin above	
Loading Area	1.20 m.

Locker*

Length	1.20 m.	} approx. 1.9 Sq. m.
Width	1.60 m.	
Height34 m.	
Loading Space65 cu. m.	

Weight in kg.	Proper Weight	Unladen Weight	Payload	Total Weight	Number of Seats
Delivery Van	900	1000 ^o	800	1800	2—3
Pick-up with tarpaulin	935	1035 ^o	785	1820	2—3
Pick-up with tarpaulin	935	1070 ^o	750	1820	2—3
Kombi	925	1025 ^o	775	1800	2—3
Micro Bus	1065	1090	710	1800	8
Ambulance	1185	1210	590	1800	6

^o including driver

PERFORMANCE

Maximum and Cruising Speed	80 km./h. (50 M. P. H.) at 3300 R. P. M.
Climbing Ability First Speed	24.5 % (13,5 ^o)
Second Speed	12 % (6 ^o)
Third Speed	7,5 % (4,5 ^o)
Top Speed	4 % (2,5 ^o)

Permissible Axle Loads in kg.	Front	Rear
Delivery Van, Kombi, Micro Bus, Ambulance	925	925
Pick-up	1000	1000

FUEL CONSUMPTION

Average Consumption	Metric — 9.5 Liters per 100 km. U. S. — 25 Miles per Gallon Imp. — 30 Miles per Gallon
Pick-up with tarpaulin	Approx. — 10 Liters per 100 km. U. S. — 24 Miles per Gallon Imp. — 28 Miles per Gallon
Fuel Tank Capacity	Metric — 40 Liters U. S. — 10.6 Gallons Imp. — 8.8 Gallons
Oil Consumption05 to .14 Liter per 100 km.

MAINTENANCE CHART

Km. 500 300	Al		Operation	Every
	2000	1200		
			Clean air cleaner	4000 km. 2400 Miles
			Check and adjust fan belt	
			Clean fuel system Check carburetor adjustment	
			Check breaker points and ignition timing	
			Check and adjust valve clearance	
			Test battery	
			Check operation of lights, signals and instruments	
			Check generator and connections	
			Check and set spark plugs	
			Check front wheel bearings, torsion arm link pins, steering, and toe-in	
			Check tire pressure and tighten wheel bolts Rotate wheels from 4000 km. (2400 miles) onwards	
			Test brakes and check brake fluid level	
			Check tightness and effect of shock absorbers	
			Check clutch pedal free play	
			Check door rubber buffers and striker plates	
			Check automatic cooling air regulation	12000 km.
			Inspect transmission and engine for oil leaks	
			Engine, especially exhaust system, carburetor, intake manifold and fuel pump	7200 Miles
			Chassis, body, axles, steering system	

} Check tightness of nuts and bolts

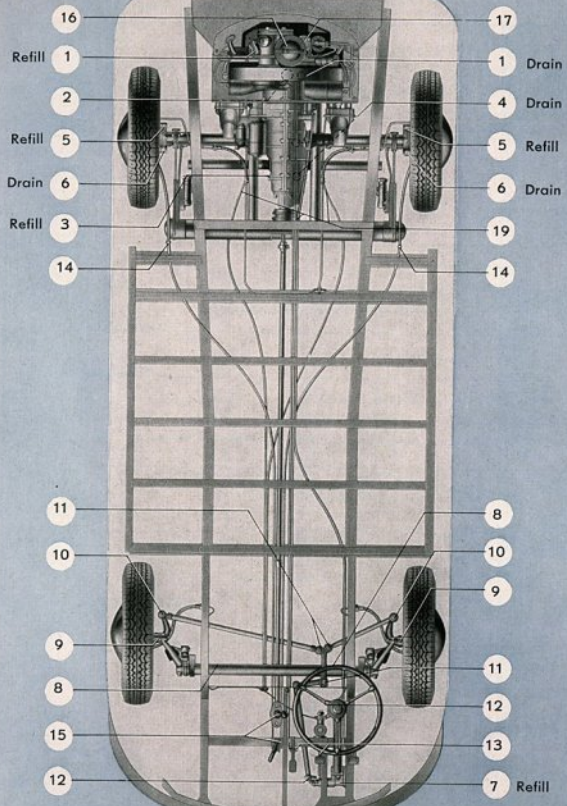

LUBRICATION CHART

km. Miles	AI					No.	Lubrication points	Mark	Every
	500	1000	2000	3000	4000				
						9	King pins	F	1000 km. 600 Miles
						10	Tie rod ends, outer	F	
						1	Engine: change oil	M	2000 km. 1200 Miles
						8	Front axle tubes	F	
						11	Steering drop arm, tie rod ends, inner Door hinges	F M	
						3	Transmission case: check oil level	G	4000 km. 2400 Miles
						5	Reduction gear cases: check oil level	G	
						7	Steering gear: check oil level	G	
						12	Draglink	F	
						13	Foot pedal bearing	F	
						16	Carburetor controls and door hinges	M	
						17	Ignition distributor cam Door and lid locks	F F	
						2	Engine: clean oil strainer		12000 km. 7200 Miles
						4	Transmission case: change oil	G	
						6	Reduction gear cases: change oil	G	
						14	Brake cables	F	
						15	Gearshift and hand brake levers	F	
						19	Front wheel bearings, carburetor, clutch, heat control cables	F F	When cold season begins

LUBRICANTS

Lubricant	Lubrication points	Mark	Specifications
Engine oil	Engine	M	 SAE 30 SAE 20 SAE 10 W
Transmission oil	Transmission case, reduction gear cases, steering gear case	G	SAE 90
Universal grease	Front axle, tie rod ends, Front wheel bearings, Brake cables, pedal bearing, Gearshift and hand brake levers, Ignition distributor cams, Door and lid locks	F	Anti-freeze, water-repellent grease

VW-Transporter, Phantom View

- 1 - Steering Gear
- 2 - Brake Master Cylinder
- 3 - Front Shock Absorber
- 4 - Front Axle
- 5 - Hot Air Vent
- 6 - Torsion Bar Bearing
- 7 - Brake Wheel Cylinder
- 8 - Reduction Gear
- 9 - Rear Axle
- 10 - Transmission Case
- 11 - Fuel Tap
- 12 - Starting Motor
- 13 - Fuel Tank
- 14 - Fuel Pump
- 15 - Distributor
- 16 - Carburetor
- 17 - Generator
- 18 - Battery

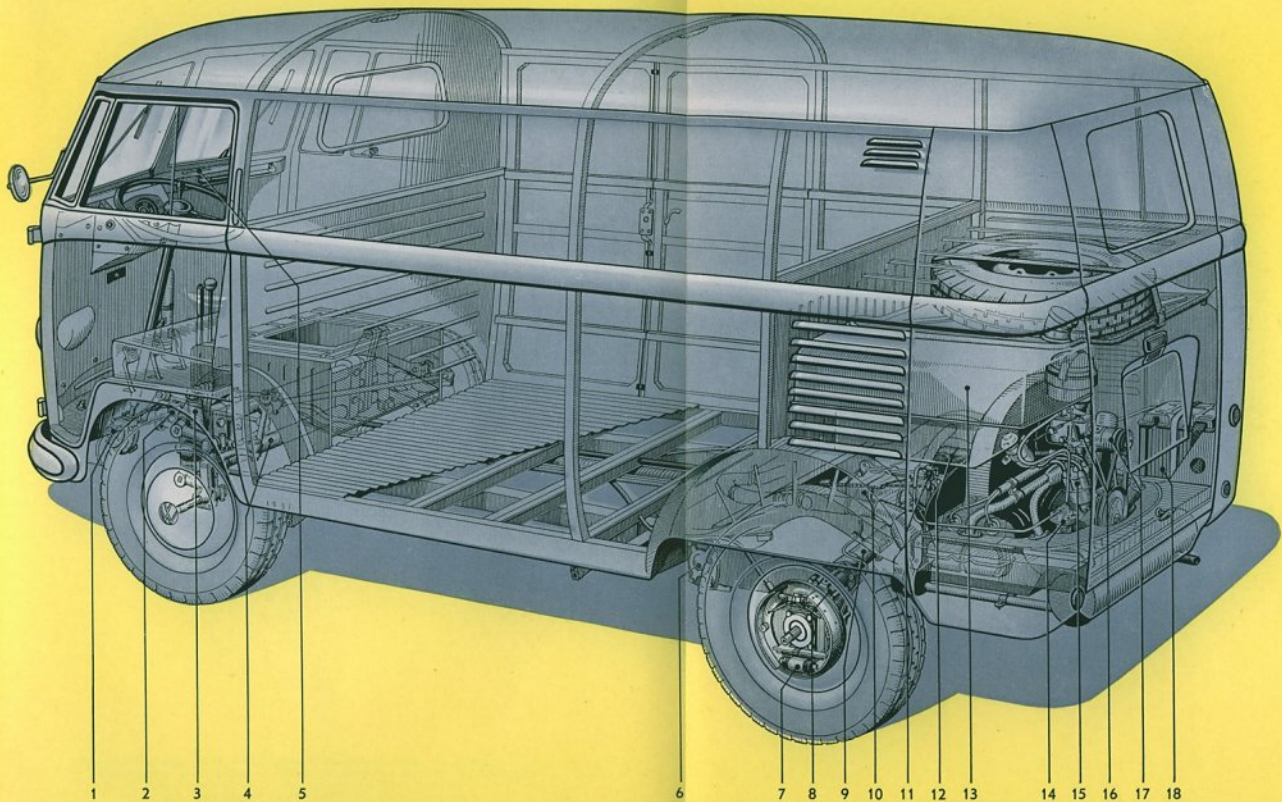

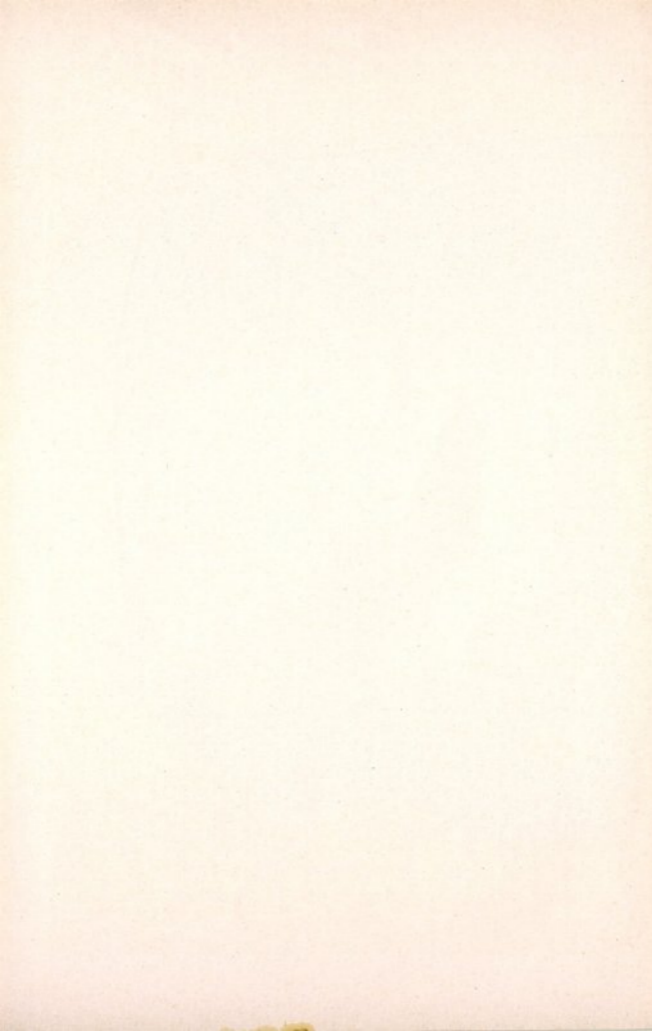

Tools and Accessories

- 1 Fan Belt
- 1 Tool Bag
- 1 Starting Handle
- 1 Spare Wheel, complete
- 1 Jack
- 1 Combination Pliers
- 1 Screw Driver 0.8 mm.
- 1 Screw Driver 0.5 mm.
- 1 Box Wrench 36 mm.
- 1 Socket Wrench 14 mm.
- 1 Socket Wrench for Spark Plug, Wheel Bolt
and Jack
- 1 Open End Wrench 8/12 mm.
- 1 Tommy Bar (Mandrel) for Socket Wrench

The VOLKSWAGENWERK GMBH reserves the right to make any changes in or improvements on its products without imposing any liability or obligation upon itself to install them on its products previously manufactured.
All rights reserved in accordance with the law of copyright.

